



Sycamore Series

VARIABLE SPEED GEOTHERMAL HEAT PUMPS

3 TO 5 TONS

Submittal Data
English Language
IP/Metric Units
SD2700AGB 12/22



Contractor: _____ P.O.: _____

Engineer: _____

Project Name: _____ Unit Tag: _____

Sycamore Series
3 - 5 Tons 60Hz



Model Nomenclature

Sycamore VS Water-to Air

1-2	3	4	5-7	8	9	10	11	12	13	14	15	16	17
14	1	*	036	T	L	1	1	1	C	0	0	K	0

Model

14 - Sycamore Variable Speed

Future Option

0 - Standard

Type

1 - Vertical
2 - Horizontal

Controls Option

K - Aurora VS Controls w/ Performance Monitoring

Intake

* - Factory Use Only

Future Option

0 - Standard

Unit Capacity

036, 048, 060

Filter Option

0 - 2" MERV 11 FILTER

Discharge Configuration

T - Top (Vertical)
B - Bottom (Vertical)
R - Rear (Vertical)
E - End (Horizontal)
S - Side (Horizontal)

Coax Option

C - Copper
N - Cupronickel

Air Configuration

L - Left
R - Right

Blower Option

1 - ECM
2 - High Static ECM Blower (036)

Voltage

1 - 208-230/60/1

Hot Water Generation Option

0 - No HWG
1 - HWG with factory installed pump

Rev. 11/10/2022

The manufacturer works continually to improve its products. As a result, the design and specifications of each product at the time of order may be changed without notice. Purchaser's approval of this data set signifies that the equipment is acceptable under the provisions of the job specification. Statements and other information contained herein are not express warranties and do not form the basis of any bargain between the parties, but are merely the manufacturer's opinion or commendation of its products.

Contractor: _____ P.O.: _____

Engineer: _____

Project Name: _____ Unit Tag: _____

Sycamore Series
3 - 5 Tons 60Hz



AHRI/ISO 13256-1 Performance Ratings

Variable Speed ECM Motor

AHRI/ASHRAE/ISO 13256-1
English (IP) Units

Model	Capacity Modulation	Flow Rate Clg/Htg	Water Loop Heat Pump				Ground Water Heat Pump				Ground Loop Heat Pump			
			Cooling EWT 86°F		Heating EWT 68°F		Cooling EWT 59°F		Heating EWT 50°F		Cooling Full Load 77°F Part Load 68°F		Heating Full Load 32°F Part Load 41°F	
			Capacity Btuh	EER Btuh/W	Capacity Btuh	COP	Capacity Btuh	EER Btuh/W	Capacity Btuh	COP	Capacity Btuh	EER Btuh/W	Capacity Btuh	COP
036	Full	1300/1500	32,300	17.7	51,000	5.3	38,000	31.2	41,700	4.5	35,800	21.6	32,900	3.5
	Part		11,000	21.1	17,000	7.6	12,500	50.0	14,000	5.9	13,400	39.0	12,000	5.1
048	Full	1500/1800	40,700	16.9	67,000	4.9	49,000	30.0	55,200	4.0	45,000	20.0	43,500	3.4
	Part		16,000	24.0	24,000	7.8	19,000	56.0	19,000	6.0	18,000	43.5	16,300	5.1
060	Full	1800/2200	50,000	15.9	79,000	4.9	60,000	27.1	66,000	4.3	56,000	19.1	51,700	3.4
	Part		20,100	22.3	29,100	7.6	22,500	55.0	23,000	5.8	22,800	40.0	20,000	5.1

Cooling capacities based upon 80.6°F DB, 66.2°F WB entering air temperature
Heating capacities based upon 68°F DB, 59°F WB entering air temperature
All ratings based upon 208V operation

1/15/21

Energy Star Compliance Table

Model	Tier 3	
	Ground Water	Ground Loop
036	Yes	Yes
048	Yes	Yes
060	Yes	Yes

6/1/12

Energy Star Rating Criteria

In order for water-source heat pumps to be Energy Star rated they must meet or exceed the minimum efficiency requirements listed below. Tier 3 represents the current minimum efficiency water source heat pumps must have in order to be Energy Star rated.

Tier 3: 1/1/2012 – No Effective End Date Published

Water-to-Air	EER	COP
Ground Loop	17.1	3.6
Ground Water	21.1	4.1
Water-to-Water		
Ground Loop	16.1	3.1
Ground Water	20.1	3.5



The manufacturer works continually to improve its products. As a result, the design and specifications of each product at the time of order may be changed without notice. Purchaser's approval of this data set signifies that the equipment is acceptable under the provisions of the job specification. Statements and other information contained herein are not express warranties and do not form the basis of any bargain between the parties, but are merely the manufacturer's opinion or commendation of its products.

Contractor: _____ P.O.: _____

Engineer: _____

Project Name: _____ Unit Tag: _____

Sycamore Series
3 - 5 Tons 60Hz



Vertical Dimensional Data

Top Air Discharge

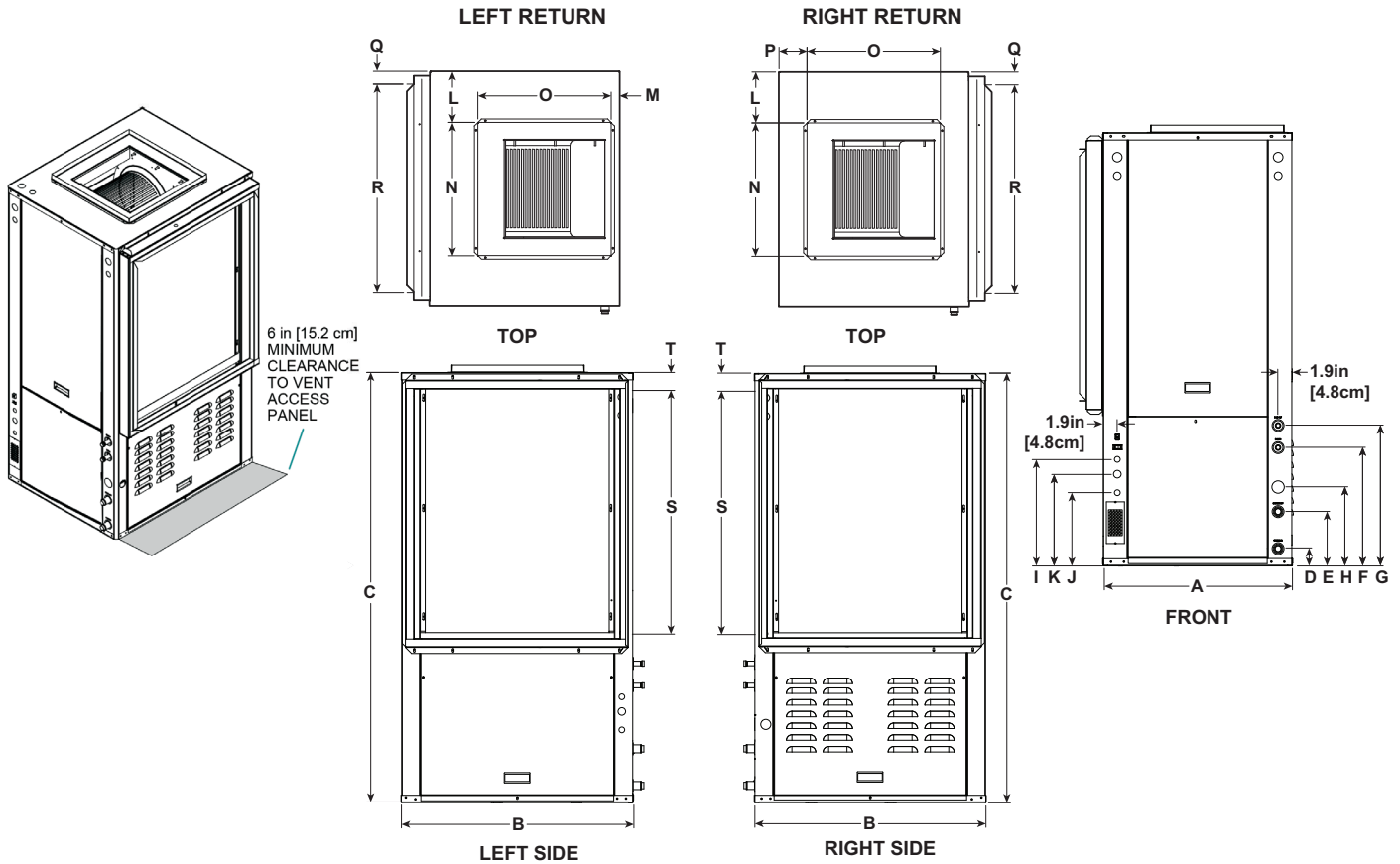

Vertical Top Flow Model	Overall Cabinet			Water Connections							Electrical Connections			Discharge Connection duct flange installed (±0.10 in)					Return Connection using std deluxe filter rack (±0.10 in)				
	A	B	C	D	E	F	G	H	Loop	HWG	I	J	K	L	M	N	O	P	Q	R	S	T	
	Width	Depth	Height	Loop In	Loop Out	HWG In	HWG Out	Condensate	Water FPT	Sweat (I.D.)	1/2 in. cond Low Voltage	1/2 in. cond Ext Pump	3/4 in. cond Power Supply			Supply Width	Supply Depth		Return Depth	Return Height			
036	in.	25.6	31.6	54.4	2.3	7.3	15.9	18.9	10.6	1 in. Swivel	1/2 in. Female	14.3	9.8	12.3	6.9	1.1	18.0	18.0	3.8	1.7	28.1	30.0	1.7
	cm.	65.0	80.3	138.2	5.8	18.5	40.4	48.0	26.9			36.3	24.9	31.2	17.5	2.8	45.7	45.7	9.7	4.3	71.4	76.2	4.3
048	in.	25.6	31.6	54.4	2.3	7.3	15.9	18.9	10.6	1 in. Swivel	1/2 in. Female	14.3	9.8	12.3	6.9	1.1	18.0	18.0	3.8	1.7	28.1	30.0	1.7
	cm.	65.0	80.3	138.2	5.8	18.5	40.4	48.0	26.9			36.3	24.9	31.2	17.5	2.8	45.7	45.7	9.7	4.3	71.4	76.2	4.3
060	in.	25.6	31.6	58.4	2.3	7.3	15.9	18.9	10.6	1 in. Swivel	1/2 in. Female	14.3	9.8	12.3	6.9	1.1	18.0	18.0	3.8	1.7	28.1	34.0	1.7
	cm.	65.0	80.3	148.3	5.8	18.5	40.4	48.0	26.9			36.3	24.9	31.2	17.5	2.8	45.7	45.7	9.7	4.3	71.4	86.4	4.3

Condensate is 3/4 in. PVC female glue socket and is switchable from side to front
 Unit shipped with deluxe 2 in. (field adjustable to 1 in.) duct collar/filter rack extending from unit 3.25 in. and is suitable for duct connection.
 Discharge flange is field installed and extends 1 in. [25.4mm] from cabinet
 Decorative molding and/or water connections extend 1.2 in. [30.5mm] beyond front of cabinet.
 Louvered vents in the compressor section right side access panel extend 1/2 in. [12.7 mm] from side of cabinet. Allow 6" clearance for venting.
 Top auxiliary electric heat power knockouts are 1.125", 1.375", and 2".

6/29/12

The manufacturer works continually to improve its products. As a result, the design and specifications of each product at the time of order may be changed without notice. Purchaser's approval of this data set signifies that the equipment is acceptable under the provisions of the job specification. Statements and other information contained herein are not express warranties and do not form the basis of any bargain between the parties, but are merely the manufacturer's opinion or commendation of its products.

Contractor: _____ P.O.: _____

Engineer: _____

Project Name: _____ Unit Tag: _____



Vertical Dimensional Data cont.

Bottom Air Discharge

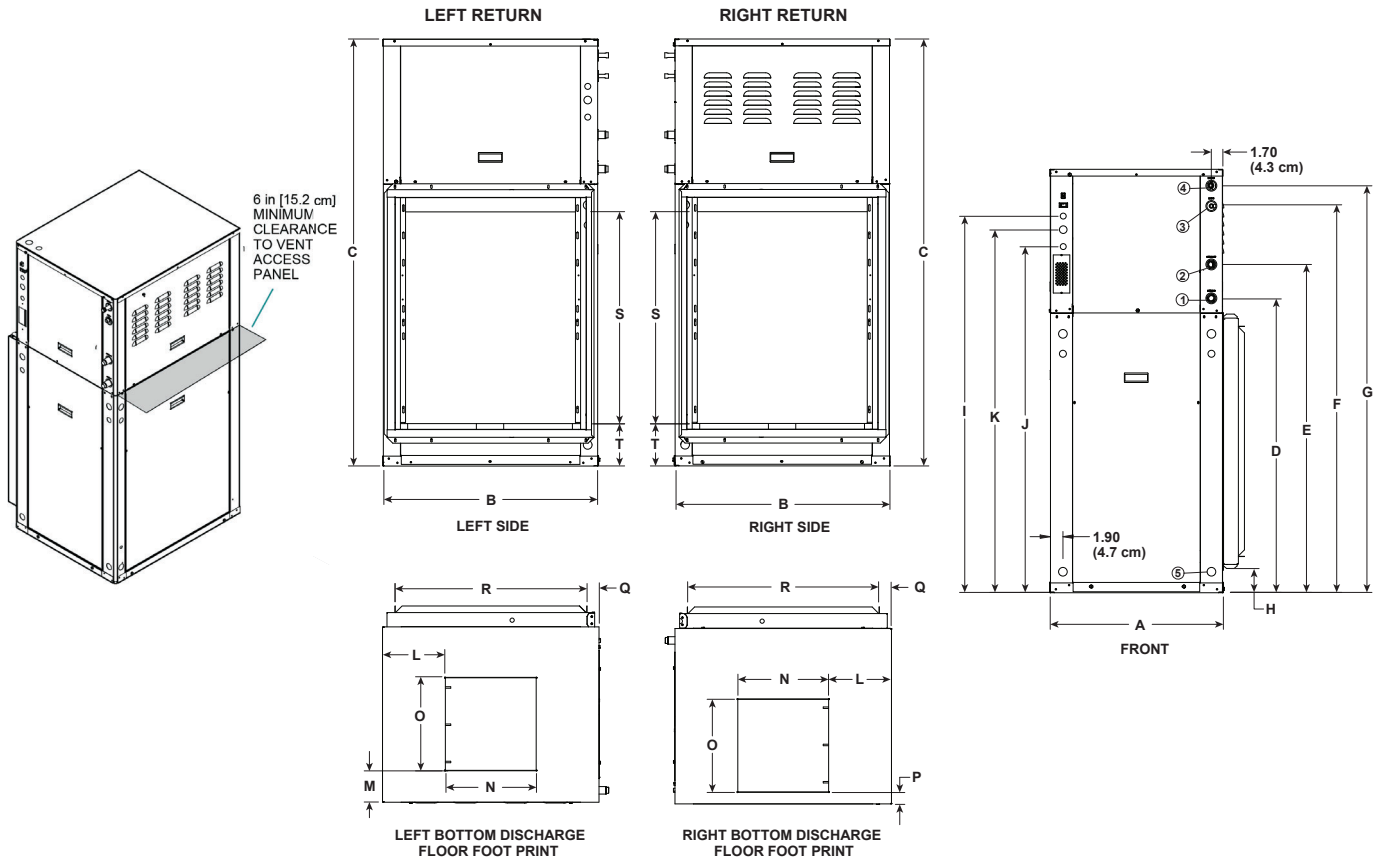

Bottomflow Models	Overall Cabinet			Water Connections							Electrical Knockouts			Discharge Connection duct flange installed (±0.10 in)					Return Connection using std deluxe filter rack (±0.10 in)				
	A	B	C	1	2	3	4	5	Loop Water FPT	HWG Sweat (I.D.)	I	J	K	L	M	N	O	P	Q	R	S	T	
	Width	Depth	Height	D In	E Out	F HWG In	G HWG Out	H Condensate			1/2 in. cond	1/2 in. cond	3/4 in. cond										Low Voltage
036-060	in.	25.5	31.5	62.5	43.4	48.4	57.0	60.0	3.1	1 in.	1/2 in.	51.1	55.6	53.6	9.1	4.8	13.4	13.6	1.7	1.8	28.1	34.0	5.6
	cm.	64.8	80.0	158.8	110.2	122.9	144.8	152.4	7.9	Swivel	Female	129.8	141.2	136.1	23.1	12.2	34.0	34.5	4.3	4.6	71.4	86.4	14.2

Condensate is 3/4 in. PVC female glue socket and is switchable from side to front

Unit shipped with deluxe 2 in. (field adjustable to 1 in.) duct collar/filter rack extending from unit 3.25 in. and is suitable for duct connection.

Decorative molding and/or water connections extend 1.2 in. [30.5mm] beyond front of cabinet.

Louvered vents in the compressor section right side access panel extend 1/2 in. [12.7 mm] from side of cabinet. Allow 6" clearance for venting.

Top auxiliary electric heat power knockouts are 1.125", 1.375", and 2".

4/30/12

Contractor: _____ P.O.: _____

Engineer: _____

Project Name: _____ Unit Tag: _____

Sycamore Series
3 - 5 Tons 60Hz



Vertical Dimensional Data cont.

Rear Air Discharge

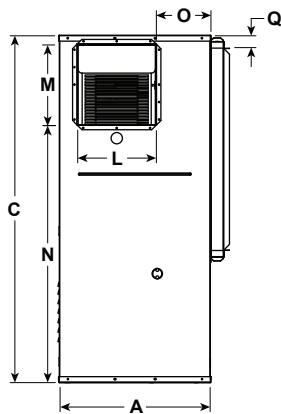
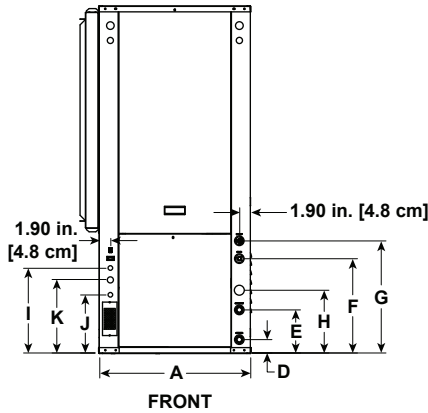
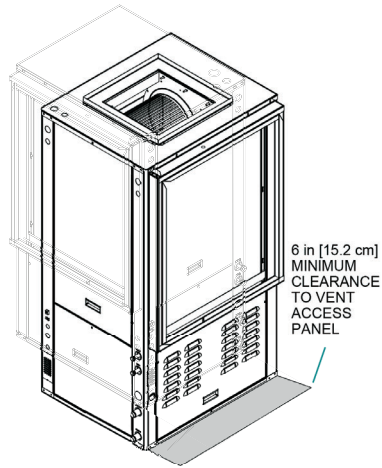

REAR VIEW
LEFT RETURN

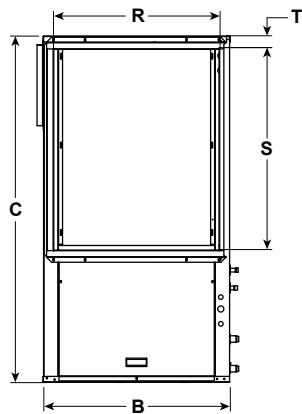

SIDE VIEW
LEFT RETURN

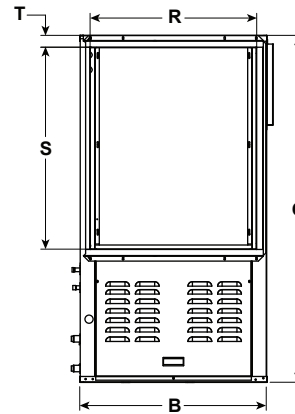

SIDE VIEW
RIGHT RETURN

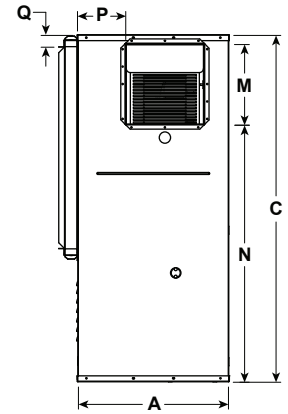

REAR VIEW
RIGHT RETURN

Vertical Rear Discharge Model	Overall Cabinet			Water Connections							Electrical Connections			Discharge Connection duct flange installed (±0.10 in)					Return Connection using std deluxe filter rack (±0.10 in)				
	A Width	B Depth	C Height	D Loop In	E Loop Out	F HWG In	G HWG Out	H Condensate	Loop Water FPT	HWG Sweat (I.D.)	I 1/2 in. cond Low Voltage	J 1/2 in. cond Ext Pump	K 3/4 in. cond Power Supply	L Supply Width	M Supply Depth	N	O	P	Q	R Return Depth	S Return Height	T	
036	in.	25.6	31.6	54.4	2.3	7.3	15.9	18.9	10.6	1 in. Swivel	1/2 in. Female	14.3	9.8	12.3	13.3	13.6	39.4	9.1	8.1	1.7	28.1	30.0	1.7
	cm.	65.0	80.3	138.2	5.8	18.5	40.4	48.0	26.9			36.3	24.9	31.2	33.8	34.5	100.1	23.1	20.6	4.3	71.4	76.2	4.3
048	in.	25.6	31.6	54.4	2.3	7.3	15.9	18.9	10.6	1 in. Swivel	1/2 in. Female	14.3	9.8	12.3	13.3	13.6	39.4	9.1	8.1	1.7	28.1	30.0	1.7
	cm.	65.0	80.3	138.2	5.8	18.5	40.4	48.0	26.9			36.3	24.9	31.2	33.8	34.5	100.1	23.1	20.6	4.3	71.4	76.2	4.3
060	in.	25.6	31.6	58.4	2.3	7.3	15.9	18.9	10.6	1 in. Swivel	1/2 in. Female	14.3	9.8	12.3	13.3	13.6	43.4	9.1	8.1	1.7	28.1	34.0	1.7
	cm.	65.0	80.3	148.3	5.8	18.5	40.4	48.0	26.9			36.3	24.9	31.2	33.8	34.5	110.2	23.1	20.6	4.3	71.4	86.4	4.3

Condensate is 3/4 in. PVC female glue socket and is switchable from side to front
 Unit shipped with deluxe 2 in. (field adjustable to 1 in.) duct collar/filter rack extending from unit 3.25 in. and is suitable for duct connection.
 Discharge flange is field installed and extends 1 in. [25.4mm] from cabinet
 Decorative molding and/or water connections extend 1.2 in. [30.5mm] beyond front of cabinet.
 Louvered vents in the compressor section right side access panel extend 1/2 in. [12.7 mm] from side of cabinet. Allow 6" clearance for venting.
 Top auxiliary electric heat power knockouts are 1.125", 1.375", and 2".

6/29/12

Contractor: _____ P.O.: _____

Engineer: _____

Project Name: _____ Unit Tag: _____

Sycamore Series
3 - 5 Tons 60Hz



Horizontal Dimensional Data

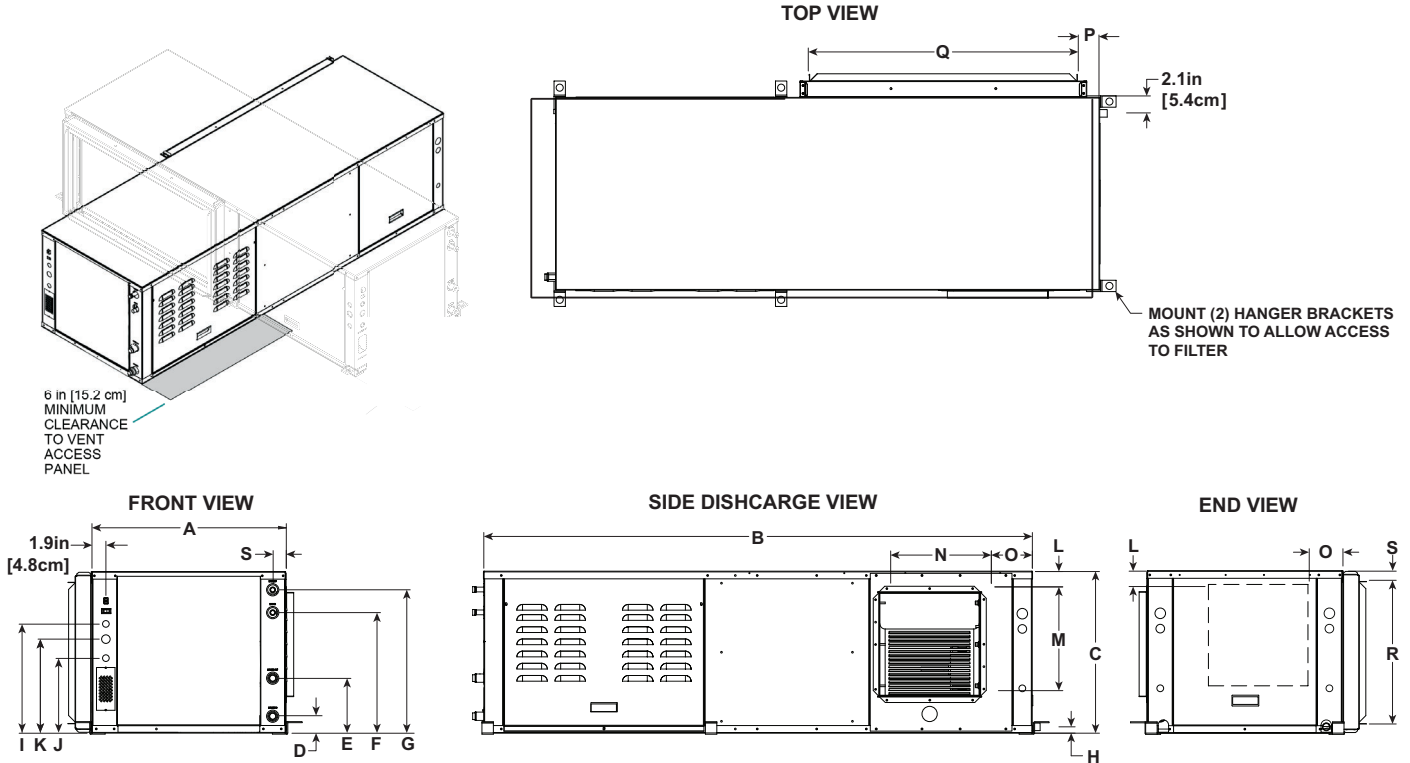

AS SHOWN LR UNIT (RR UNIT ON OPPOSITE SIDE—SAME DIMENSIONS)

Horizontal Models	Overall Cabinet			Water Connections							Electrical Connections			Discharge Connection duct flange installed (±0.10 in)				Return Connection using std deluxe filter rack (±0.10 in)				
	A	B	C	D	E	F	G	H	Loop Water FPT	HWG Sweat (I.D.)	I 1/2 in. cond	J 1/2 in. cond	K 3/4 in. cond	L	M Supply Height	N Supply Depth	O	P	Q Return Depth	R Return Height	S	
	Width	Depth	Height	In	Out	HWG In	HWG Out	Condensate			Low Voltage	Ext Pump	Power Supply									
036	in.	25.6	77.0	21.3	2.3	7.3	15.9	18.9	0.8	1 in. Swivel	1/2 in. Female	14.3	9.8	12.3	SEE CHART	13.6	13.2	SEE CHART	2.8	40.4	18.9	1.3
	cm.	65.0	195.6	54.1	5.8	18.5	40.4	48.0	2.0			36.3	24.9	31.2		34.5	33.5		7.1	102.6	48.0	3.3
048	in.	25.6	77.0	21.3	2.3	7.3	15.9	18.9	0.8	1 in. Swivel	1/2 in. Female	14.3	9.8	12.3	SEE CHART	13.6	13.2	SEE CHART	2.8	40.4	18.9	1.3
	cm.	65.0	195.6	54.1	5.8	18.5	40.4	48.0	2.0			36.3	24.9	31.2		34.5	33.5		7.1	102.6	48.0	3.3
060	in.	25.6	82.0	21.3	2.3	7.3	15.9	18.9	0.8	1 in. Swivel	1/2 in. Female	14.3	9.8	12.3	SEE CHART	13.6	13.2	SEE CHART	2.8	45.4	18.9	1.3
	cm.	65.0	208.3	54.1	5.8	18.5	40.4	48.0	2.0			36.3	24.9	31.2		34.5	33.5		7.1	115.3	48.0	3.3

Condensate is 3/4 in. PVC female glue socket and is switchable from side to front
 Unit shipped with deluxe 2 in. (field adjustable to 1 in.) duct collar/filter rack extending from unit 3.25 in. and is suitable for duct connection.
 Discharge flange is field installed and extends 1 in. [25.4mm] from cabinet
 Decorative molding and/or water connections extend 1.2 in. [30.5mm] beyond front of cabinet.
 Louvered vents in the compressor section right side access panel extend 1/2 in. [12.7 mm] from side of cabinet. Allow 6" clearance for venting.

6/29/12

Units Not Shown Above		L	O
Right Return End Discharge	in	2.8	4.6
	cm	7.1	11.8
Right Return Side Discharge	in	4.9	6.9
	cm	12.4	17.5
Left Return End Discharge	in	4.9	7.6
	cm	12.4	19.4
Left Return Side Discharge	in	2.8	6.9
	cm	7.1	17.5

The manufacturer works continually to improve its products. As a result, the design and specifications of each product at the time of order may be changed without notice. Purchaser's approval of this data set signifies that the equipment is acceptable under the provisions of the job specification. Statements and other information contained herein are not express warranties and do not form the basis of any bargain between the parties, but are merely the manufacturer's opinion or commendation of its products.

Contractor: _____ P.O.: _____

Engineer: _____

Project Name: _____ Unit Tag: _____



Physical Data

Model				
		036	048	060
Compressor (1 each)		Variable Speed Scroll		
Factory Charge R410a, oz [kg] (Aluminum tube and fin air coil)	Vertical	90 [2.55]	120 [3.40]	140 [3.96]
Factory Charge R410a, oz [kg] (Aluminum tube and fin air coil)	Horizontal	86 [2.44]	108 [3.06]	148 [4.19]
ECM Blower Motor & Blower				
Blower Motor Type/Speeds	ECM	Variable Speed		
Blower Motor- hp [W]	ECM	1/2 [373]	1 [746]	1 [746]
High Static Blower Motor - hp [W]	ECM	1 [746]	n/a	n/a
Blower Wheel Size (Dia x W), in. [mm]	ECM	11 x 10 [279 x 254]	11 x 10 [279 x 254]	11 x 10 [279 x 254]
High Static Blower Wheel Size - [Dia. x W], in. [mm]	ECM	11 x 10 [279 x 254]	n/a	n/a
Coax and Water Piping				
Water Connections Size - Swivel - in [mm]		1" [25.4]	1" [25.4]	1" [25.4]
HWG Connection Size - Female Sweat I.D. - in [mm]		1/2" [12.7]	1/2" [12.7]	1/2" [12.7]
Coax & Piping Water Volume - gal [l]		1.3 [4.9]	2.3 [8.7]	2.3 [8.7]
Vertical				
Air Coil Dimensions (H x W), in. [mm]		32 x 25 [813 x 635]	32 x 25 [813 x 635]	36 x 25 [914 x 635]
Air Coil Total Face Area, ft2 [m2]		5.6 [0.570]	5.6 [0.570]	6.3 [0.641]
Air Coil Tube Size, in [mm]		3/8 [9.5]	3/8 [9.5]	3/8 [9.5]
Air Coil Number of rows		3	3	4
Filter Standard - 2" [51mm] Pleated MERV11 Throwaway, in [mm]		32 x 30 [813 x 762]	32 x 30 [813 x 762]	36 x 30 [914 x 762]
Weight - Operating, lb [kg]		331 [150]	354 [161]	372 [169]
Weight - Packaged, lb [kg]		351 [159]	374 [170]	392 [178]
Horizontal				
Air Coil Dimensions (H x W), in. [mm]		20 x 40 [508 x 1016]	20 x 40 [508 x 1016]	20 x 4 [508 x 1143]
Air Coil Total Face Area, ft2 [m2]		5.6 [0.570]	5.6 [0.570]	6.3 [0.641]
Air Coil Tube Size, in [mm]		3/8 [9.5]	3/8 [9.5]	3/8 [9.5]
Air Coil Number of rows		3	3	4
Filter Standard - 2" [51mm] Pleated MERV11 Throwaway, in [mm]		1 - 20 x 20 [508 x 508] 1 - 20 x 22 [508 x 559]	1 - 20 x 20 [508 x 508] 1 - 20 x 22 [508 x 559]	1 - 20 x 25 [508 x 635] 1 - 20 x 22 [508 x 559]
Weight - Operating, lb [kg]		365 [166]	388 [176]	402 [182]
Weight - Packaged, lb [kg]		395 [179]	418 [190]	432 [196]

*Bottom flow 036-060 models use the 2in. [51mm] MERV 11 throwaway in. [mm] 36 x 30 [914 x 762] filter.

12/3/2020

Contractor: _____ P.O.: _____

Engineer: _____

Project Name: _____ Unit Tag: _____

Sycamore Series
3 - 5 Tons 60Hz



Auxiliary Heat Ratings

Model	kW		Stages	Btu/h		Min CFM	Model Compatibility		
	208V	230V		208V	230V		036	048	060
EAL(H)10A	7.2	9.6	2	24,600	32,700	1100	•	•	•
EAL(H)15A	10.8	14.4	2	36,900	49,100	1250	•	•	•
EAL(H)20A	14.4	19.2	2	49,200	65,500	1500		•	•

Air flow level for auxiliary heat (Aux) must be above the minimum cfm in this table
Order the "H" part number when installed on horizontal and vertical rear discharge units

6/1/12

Auxiliary Heat Electrical Data

Model	Supply Circuit	Heater Amps		Min Circuit Amp		Max Fuse (USA)		Max Fuse (CAN)		Max CKT BRK	
		208 V	240 V	208 V	240 V	208 V	240 V	208 V	240 V	208 V	240 V
EAL(H)10A	Single	34.7	40	53.3	60	60	60	60	60	60	60
EAL(H)15A	Single	52.0	60	75	85	80	90	80	90	70	100
	L1/L2	34.7	40	53.3	60	60	60	60	60	60	60
	L3/L4	17.3	20	21.7	25	25	25	25	25	20	30
EAL(H)20A	Single	69.3	80	96.7	110	100	110	100	110	100	100
	L1/L2	34.7	40	53.3	60	60	60	60	60	60	60
	L3/L4	34.7	40	43.3	50	45	50	45	50	40	50

All heaters rated single phase 60 cycle and include unit fan load
All fuses type "D" time delay (or HACR circuit breaker in USA)

6/1/12

Electrical Data

Model	Rated Voltage	Voltage Min/Max	Compressor		Drive		HWG Pump FLA	Ext Loop FLA	Blower Motor FLA	Total Unit FLA	Minimum Circuit Amp	Max Fuse HACR Breaker
			LRA	CMCC	LRA	Internal Breaker						
036	208-230/60/1	187/253	10.2	18.0	22.0	30.0	0.4	5.4	4.0	31.8	37.3	40
*036	208-230/60/1	187/253	10.2	18.0	22.0	30.0	0.4	5.4	7.0	34.8	40.3	45
048	208-230/60/1	187/253	12.0	23.5	28.0	35.0	0.4	5.4	7.0	40.8	47.8	50
060	208-230/60/1	187/253	12.0	30.0	33.0	40.0	0.4	5.4	7.0	45.8	54.1	60

*With optional 1 hp Variable Speed ECM Motor
Rated Voltage of 208/230/60/1
HACR circuit breaker in USA only
All fuses Class RK-5

3/26/12

The manufacturer works continually to improve its products. As a result, the design and specifications of each product at the time of order may be changed without notice. Purchaser's approval of this data set signifies that the equipment is acceptable under the provisions of the job specification. Statements and other information contained herein are not express warranties and do not form the basis of any bargain between the parties, but are merely the manufacturer's opinion or commendation of its products.

Contractor: _____ P.O.: _____

Engineer: _____

Project Name: _____ Unit Tag: _____



Blower Performance Data

Variable Speed ECM Blower Motor

Model	Max ESP	Air Flow											
		Speed 1	Speed 2	Speed 3	Speed 4	Speed 5	Speed 6	Speed 7	Speed 8	Speed 9	Speed 10	Speed 11	Speed 12
036	0.50	285	380 G	525 L	675	815	980	1100	1220	1330	1440 H	1540 Aux	1575
036 w/1hp*	0.75	480	565 G	665 L	761	870	1000	1100	1200	1300	1410 H	1520 Aux	1630
048	0.75	475	620 G	730 L	850	1020	1140	1270	1400	1520	1650 H	1790 Aux	1925
060	0.75	400	600 G	830 L	1050	1230	1400	1560	1700	1870	2010 H	2140 Aux	2265
**VS Compressor Speed				1-2	3-4			5-6	7-8		9-10	11-12	

** VS Compressor speed is given for the factory default cfm settings. When the cfm default settings are changed it will change the relationship to the compressor speed that is shown in the table. In cooling mode compressor speeds 10-12 are only available when SuperBoost mode is selected at the thermostat. 6/7/12

* Optional 1 hp Variable Speed ECM

Factory settings are at recommended L, H and Aux positions

"G" may be located anywhere within the airflow table

"L" setting should be located within the boldface cfm range

"H" setting MUST be located within the shaded cfm range

"Aux" setting MUST be equal to or greater than "H" setting

"Aux" setting MUST be equal to or greater than the minimum allowable cfm for the auxiliary heater kit (see auxiliary heat ratings table)

Cfm is controlled within 5% up to the maximum ESP

Max ESP includes allowance for wet coil and standard filter

Setting Blower Speed - Variable Speed ECM

The ABC board's Yellow Config LED will flash the current ECM blower speed selections for G, low, and high continuously with a short pause in between. The speeds can also be confirmed with the AID Tool under the Setup/ECM Setup screen. The Aux will not be flashed but can be viewed in the AID Tool. The ECM blower motor speeds can be field adjusted with or without using an AID Tool.

Variable Speed ECM Setup without an AID Tool

The blower speeds for G only, Low (Y1), and High (Y2/Aux) can be adjusted directly at the Aurora ABC board which utilizes the push button (SW1) on the ABC board. This procedure is outlined in the ECM Configuration Mode portion of the Aurora 'Base' Control System section. The Aux cannot be set manually without an AID Tool.

Variable Speed ECM Setup with an AID Tool

A much easier method utilizes the AID Tool to change the airflow using the procedure below. First navigate to the Setup screen and then select ECM Setup. This screen displays the current ECM settings. It allows the technician to enter the setup screens to change the ECM settings. Change the highlighted item using the ◀ and ▶ buttons and then press the ■ button to select the item.

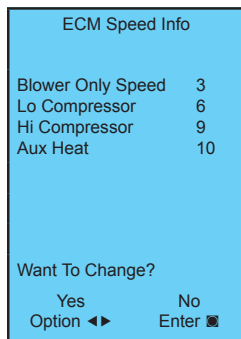

Selecting YES will enter ECM speed setup, while selecting NO will return to the previous screen.

ECM Speed Setup - These screens allow the technician to select the G, low, high, and auxiliary heat blower speed for the ECM blower motor. Change the highlighted item using the ▲ and ▼ buttons. Press the ■ button to select the speed.

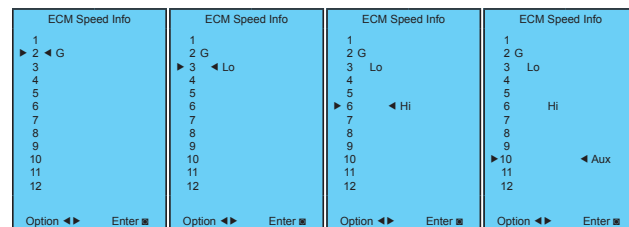

After the auxiliary heat speed setting is selected the AID Tool will automatically transfer back to the ECM Setup screen.

Cooling Airflow Setup - These screens allow the technician to select -15%, -10%, -5%, None or +5% change from the heating airflow. Change the adjustment percentage using the ▲ and ▼ buttons. Press the ■ button to save the change.

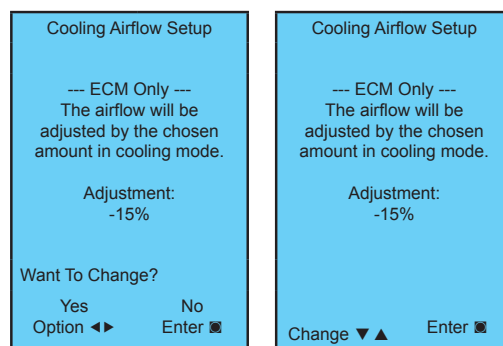

The manufacturer works continually to improve its products. As a result, the design and specifications of each product at the time of order may be changed without notice. Purchaser's approval of this data set signifies that the equipment is acceptable under the provisions of the job specification. Statements and other information contained herein are not express warranties and do not form the basis of any bargain between the parties, but are merely the manufacturer's opinion or commendation of its products.

Contractor: _____ P.O.: _____

Engineer: _____

Project Name: _____ Unit Tag: _____



Operating Limits

Operating Limits	Cooling		Heating	
	(°F)	(°C)	(°F)	(°C)
Air Limits				
Min. Ambient Air	45	7.2	45	7.2
Rated Ambient Air	80	26.7	70	21.1
Max. Ambient Air	100	37.8	85	29.4
Min. Entering Air	50	10.0	40	4.4
Rated Entering Air db/wb	80.6/66.2	27/19	68	20.0
Max. Entering Air db/wb	110/83	43/28.3	80	26.7
Water Limits				
Min. Entering Water	30	-1.1	20	-6.7
Normal Entering Water	50-110	10-43.3	30-70	-1.1
Max. Entering Water	120	48.9	90	32.2

NOTE: Minimum/maximum limits are only for start-up conditions, and are meant for bringing the space up to occupancy temperature. Units are not designed to operate at the minimum/maximum conditions on a regular basis. The operating limits are dependent upon three primary factors: 1) water temperature, 2) return air temperature, and 3) ambient temperature. When any of the factors are at the minimum or maximum levels, the other two factors must be at the normal level for proper and reliable unit operation.

Definitions

Abbreviations and Definitions

cfm = airflow, cubic feet/minute
 EWT = entering water temperature, Fahrenheit
 gpm = water flow in gallons/minute
 WPD = water pressure drop, psi and feet of water
 EAT = entering air temperature, Fahrenheit (dry bulb/wet bulb)
 HC = air heating capacity, MBtu/h
 TC = total cooling capacity, MBtu/h
 SC = sensible cooling capacity, MBtu/h
 kW = total power unit input, kilowatts
 HR = total heat of rejection, MBtu/h
 HE = total heat of extraction, MBtu/h

HWC = hot water generator capacity, MBtu/h
 EER = Energy Efficient Ratio
 = Btu output/Watt input
 COP = Coefficient of Performance
 = Btu output/Btu input
 LWT = leaving water temperature, °F
 LAT = leaving air temperature, °F
 TH = total heating capacity, MBtu/h
 LC = latent cooling capacity, MBtu/h
 S/T = sensible to total cooling ratio

Pressure Drop

Model	GPM	Pressure Drop (psi)				
		30°F	50°F	70°F	90°F	110°F
36	11.5	3.60	3.30	3.10	2.90	2.70
	9.0	2.30	2.10	2.00	1.90	1.70
	7.0	1.50	1.40	1.30	1.20	1.10
	6.0	1.20	1.15	1.10	1.05	1.00
	4.5	0.70	0.66	0.64	0.60	0.55
48	13.5	4.60	4.40	4.10	3.80	3.50
	10.5	2.90	2.70	2.50	2.30	2.20
	7.5	1.70	1.60	1.50	1.40	1.30
	6.0	1.20	1.10	1.00	0.96	0.91
	4.0	0.62	0.61	0.60	0.58	0.56
60	17.0	6.40	6.00	5.60	5.20	4.80
	13.5	4.60	4.40	4.10	3.80	3.50
	9.5	2.20	2.10	2.00	1.80	1.70
	7.5	1.70	1.60	1.50	1.40	1.30
	5.0	0.68	0.62	0.58	0.55	0.53

12/02/20

Notes to Performance Data Tables

The following notes apply to all performance data tables: Performance ratings are based on 80°F DB/67°F WB EAT for cooling and 70°F DB EAT for heating. Three flow rates are shown for each unit. The lowest flow rate shown is used for geothermal open loop/well water systems with a minimum of 50°F EWT. The middle flow rate shown is the minimum geothermal closed loop flow rate. The highest flow rate shown is optimum for geothermal closed loop systems and the suggested flow rate for boiler/tower applications. The hot water generator numbers are based on a flow rate of 0.4 gpm/ton of rated capacity with an EWT of 90°F. Entering water temperatures below 40°F assumes 15% antifreeze solution. For non-standard EAT conditions, apply the appropriate Correction Factor tables. Interpolation between EWT, gpm, and cfm data is permissible, extrapolation is not.

Contractor: _____ P.O.: _____

Engineer: _____

Project Name: _____ Unit Tag: _____

Sycamore Series
3 - 5 Tons 60Hz



Correction Factor Tables

Air Flow Corrections (Compressor Speeds 1-3)

Airflow		Cooling				Heating		
CFM Per Ton of Clg	% of Nominal	Total Cap	Sens Cap	Power	Heat of Rej	Htg Cap	Power	Heat of Ext
240	60	0.940	0.740	0.967	0.951	0.943	1.106	0.902
275	69	0.950	0.783	0.973	0.959	0.953	1.088	0.918
300	75	0.960	0.827	0.978	0.967	0.962	1.070	0.935
325	81	0.970	0.870	0.984	0.975	0.972	1.053	0.951
350	88	0.980	0.913	0.989	0.984	0.981	1.035	0.967
375	94	0.990	0.957	0.995	0.992	0.991	1.018	0.984
400	100	1.000	1.000	1.000	1.000	1.000	1.000	1.000
425	106	1.030	1.022	1.024	1.026	1.009	0.982	1.016
450	113	1.060	1.045	1.048	1.051	1.019	0.965	1.033
475	119	1.091	1.067	1.071	1.077	1.028	0.947	1.049
500	125	1.121	1.089	1.095	1.103	1.038	0.930	1.065
520	130	1.151	1.111	1.110	1.129	1.047	0.912	1.082

6/29/12

Air Flow Corrections (Compressor Speeds 4-12)

Airflow		Cooling				Heating		
CFM Per Ton of Clg	% of Nominal	Total Cap	Sens Cap	Power	Heat of Rej	Htg Cap	Power	Heat of Ext
240	60	0.928	0.747	0.936	0.929	0.961	1.097	0.938
275	69	0.940	0.789	0.946	0.941	0.967	1.081	0.948
300	75	0.952	0.831	0.957	0.953	0.974	1.064	0.959
325	81	0.964	0.873	0.968	0.965	0.980	1.048	0.969
350	88	0.976	0.916	0.979	0.976	0.987	1.032	0.979
375	94	0.988	0.958	0.989	0.988	0.993	1.016	0.990
400	100	1.000	1.000	1.000	1.000	1.000	1.000	1.000
425	106	1.020	1.023	1.004	1.018	1.010	0.966	1.018
450	113	1.056	1.042	1.008	1.035	1.020	0.932	1.036
475	119	1.072	1.079	1.011	1.053	1.029	0.898	1.054
500	125	1.087	1.095	1.015	1.070	1.039	0.865	1.071
520	130	1.099	1.113	1.019	1.088	1.049	0.831	1.089

6/14/12

Cooling Capacity Corrections

Entering Air WB °F	Total Clg Cap	Sensible Cooling Capacity Multipliers - Entering DB °F										Power Input	Heat of Rejection
		60	65	70	75	80	80.6	85	90	95	100		
55	0.898	0.723	0.866	1.048	1.185	*	*	*	*	*	*	0.985	0.913
60	0.912	0.632	0.880	1.078	1.244	1.260	*	*	*	*	*	0.994	0.927
63	0.945		0.768	0.960	1.150	1.175	*	*	*	*	*	0.996	0.954
65	0.976		0.694	0.881	1.079	1.085	1.270	*	*	*	*	0.997	0.972
66.2	0.983		0.655	0.842	1.040	1.060	1.232	*	*	*	*	0.999	0.986
67	1.000		0.616	0.806	1.000	1.023	1.193	1.330	1.480	*	*	1.000	1.000
70	1.053		0.693	0.879	0.900	0.905	1.075	1.205	1.404	*	*	1.003	1.044
75	1.168			0.687	0.715	0.875	1.040	1.261	1.476	1.476	1.007	1.007	1.141

NOTE: *Sensible capacity equals total capacity at conditions shown.

4/22/12

Heating Capacity Corrections

Ent Air DB °F	Heating Corrections		
	Htg Cap	Power	Heat of Ext
45	1.062	0.739	1.158
50	1.050	0.790	1.130
55	1.037	0.842	1.096
60	1.025	0.893	1.064
65	1.012	0.945	1.030
68	1.005	0.976	1.012
70	1.000	1.000	1.000
75	0.987	1.048	0.970
80	0.975	1.099	0.930

11/10/09

The manufacturer works continually to improve its products. As a result, the design and specifications of each product at the time of order may be changed without notice. Purchaser's approval of this data set signifies that the equipment is acceptable under the provisions of the job specification. Statements and other information contained herein are not express warranties and do not form the basis of any bargain between the parties, but are merely the manufacturer's opinion or commendation of its products.

Contractor: _____ P.O.: _____

Engineer: _____

Project Name: _____ Unit Tag: _____



Antifreeze Corrections

Catalog performance can be corrected for antifreeze use. Please use the following table and note the example given.

Antifreeze Type	Antifreeze % by wt	Heating	Cooling	Pressure Drop
EWT - °F [°C]		30 [-1.1]	90 [32.2]	30 [-1.1]
Water	0	1.000	1.000	1.000
Ethylene Glycol	10	0.973	0.991	1.075
	20	0.943	0.979	1.163
	30	0.917	0.965	1.225
	40	0.890	0.955	1.324
	50	0.865	0.943	1.419
Propylene Glycol	10	0.958	0.981	1.130
	20	0.913	0.969	1.270
	30	0.854	0.950	1.433
	40	0.813	0.937	1.614
	50	0.770	0.922	1.816
Ethanol	10	0.927	0.991	1.242
	20	0.887	0.972	1.343
	30	0.856	0.947	1.383
	40	0.815	0.930	1.523
	50	0.779	0.911	1.639
Methanol	10	0.957	0.986	1.127
	20	0.924	0.970	1.197
	30	0.895	0.951	1.235
	40	0.863	0.936	1.323
	50	0.833	0.920	1.399



WARNING: Gray area represents antifreeze concentrations greater than 35% by weight and should be avoided due to the extreme performance penalty they represent.

Antifreeze Correction Example

Antifreeze solution is Propylene Glycol 20% by weight. Determine the corrected heating and cooling performance at 30°F and 90°F respectively as well as pressure drop at 30°F for Model 036 operating at 100% capacity.

The corrected cooling capacity at 90°F would be: 35,200 MBtu/h x 0.969 = 34,109 MBtu/h

The corrected heating capacity at 30°F would be: 37,400 MBtu/h x 0.913 = 34,146 MBtu/h

The corrected pressure drop at 30°F and 11.5 gpm would be: 7.9 feet of head x 1.270 = 10.03 feet of head

Contractor: _____ P.O.: _____

Engineer: _____

Project Name: _____ Unit Tag: _____

Sycamore Series
3 - 5 Tons 60Hz



Performance Data

036 - 50% Part Load

EWT °F	WPD			HEATING - EAT 70°F							EWT °F	WPD			COOLING - EAT 80/67 °F							
	Flow gpm	PSI	FT	Airflow cfm	HC MBtuh	Power kW	HE MBtuh	LAT °F	COP	HWC MBtuh		Flow gpm	PSI	FT	Airflow cfm	TC MBtuh	SC MBtuh	S/T Ratio	Power kW	HR MBtuh	EER	HWC MBtuh
20	3.0	0.30	0.7	Operation not recommended							20	2.5	0.15	0.4	Operation not recommended							
	4.5	0.70	1.6									3.5	0.46	1.1								
	5.5	1.09	2.5	550	12.7	1.43	7.8	91.4	2.61	2.2		5.0	0.77	1.8								
30	3.0	0.30	0.7	550	13.3	1.19	9.2	92.3	3.26	2.3	30	2.5	0.15	0.3	500	18.3	12.5	0.68	0.57	20.2	32.2	-
				750	12.8	1.26	8.5	85.8	2.98	1.8					650	18.6	13.7	0.74	0.59	20.7	31.5	-
	4.5	0.68	1.6	550	13.6	1.20	9.5	92.9	3.33	2.6	3.5	0.45	1.0	500	18.5	12.6	0.68	0.54	20.4	34.3	-	
				750	14.2	1.23	10.0	87.5	3.38	2.2				650	18.8	13.8	0.73	0.57	20.8	33.1	-	
	5.5	1.06	2.4	550	15.0	1.43	10.1	95.3	3.07	2.7	5.0	0.75	1.7	500	18.6	12.6	0.68	0.52	20.4	35.6	-	
				750	15.1	1.26	10.8	88.6	3.51	2.2				650	19.1	13.8	0.72	0.55	21.0	34.7	-	
40	3.0	0.29	0.7	550	15.6	1.21	11.4	96.2	3.77	2.5	40	2.5	0.14	0.3	500	20.4	13.3	0.65	0.51	22.1	39.7	-
				750	16.1	1.23	11.9	89.9	3.83	2.2					650	20.8	14.5	0.70	0.53	22.6	38.9	-
	4.5	0.66	1.5	550	16.1	1.21	11.9	97.0	3.88	2.8	3.5	0.44	1.0	500	20.6	13.4	0.65	0.49	22.3	42.3	-	
				750	16.6	1.24	12.4	90.5	3.94	2.3				650	21.0	14.7	0.70	0.51	22.8	41.1	-	
	5.5	1.02	2.4	550	16.9	1.24	12.7	98.5	3.99	2.8	5.0	0.73	1.7	500	20.8	13.4	0.65	0.47	22.4	43.9	-	
				750	17.5	1.27	13.2	91.6	4.05	2.4				650	21.3	14.7	0.69	0.50	22.9	42.9	-	
50	3.0	0.28	0.6	550	17.8	1.23	13.7	100.0	4.27	2.8	50	2.5	0.14	0.3	500	22.2	13.6	0.61	0.45	23.7	49.7	-
				750	18.4	1.24	14.2	92.7	4.34	2.3					650	22.8	15.0	0.66	0.46	24.4	50.1	-
	4.5	0.64	1.5	550	18.5	1.23	14.3	101.1	4.41	3.0	3.5	0.42	1.0	500	22.4	13.7	0.61	0.44	23.9	51.4	-	
				750	19.0	1.24	14.8	93.5	4.49	2.5				650	23.0	15.1	0.66	0.44	24.5	51.9	-	
	5.5	0.99	2.3	550	19.3	1.26	15.0	102.5	4.51	3.1	5.0	0.70	1.6	500	22.8	14.0	0.62	0.43	24.2	52.7	-	
				750	19.9	1.27	15.6	94.6	4.59	2.8				650	23.4	15.5	0.66	0.44	24.9	53.2	-	
60	3.0	0.27	0.6	550	20.2	1.24	16.0	104.0	4.77	3.0	60	2.5	0.13	0.3	500	20.0	13.4	0.67	0.59	22.0	34.0	1.0
				750	20.7	1.25	16.4	95.6	4.85	2.5					650	20.6	14.8	0.72	0.60	22.6	34.3	1.0
	4.5	0.62	1.4	550	21.0	1.24	16.8	105.4	4.97	3.2	3.5	0.41	0.9	500	20.2	13.5	0.67	0.57	22.2	35.2	1.1	
				750	21.5	1.25	17.3	96.6	5.05	2.7				650	20.8	14.9	0.72	0.59	22.8	35.5	1.1	
	5.5	0.96	2.2	550	21.8	1.27	17.4	106.6	5.03	3.3	5.0	0.68	1.6	500	20.5	13.8	0.67	0.57	22.5	36.1	1.2	
				750	22.3	1.28	17.9	97.5	5.11	2.8				650	21.1	15.3	0.73	0.58	23.1	36.4	1.2	
70	3.0	0.26	0.6	550	22.6	1.26	18.3	108.0	5.25	3.2	70	2.5	0.13	0.3	500	17.8	13.2	0.74	0.73	20.3	24.4	1.3
				750	22.9	1.27	18.6	98.3	5.28	2.6					650	18.6	14.9	0.80	0.86	21.5	21.6	1.3
	4.5	0.60	1.4	550	23.6	1.26	19.3	109.7	5.50	3.4	3.5	0.40	0.9	500	18.0	13.3	0.74	0.71	20.4	25.3	1.4	
				750	24.0	1.25	19.7	99.6	5.61	2.9				650	18.5	14.7	0.80	0.73	21.0	25.5	1.4	
	5.5	0.93	2.1	550	24.2	1.28	19.8	110.7	5.53	3.5	5.0	0.66	1.5	500	18.3	13.6	0.75	0.71	20.7	25.9	1.5	
				750	24.6	1.28	20.2	100.4	5.63	2.9				650	18.8	15.1	0.80	0.72	21.3	26.1	1.5	
80	3.0	0.25	0.6	550	24.8	1.28	20.4	111.8	5.67	3.4	80	2.5	0.13	0.3	500	16.7	12.3	0.73	0.90	19.8	18.6	1.9
				750	25.2	1.28	20.8	101.1	5.78	2.8					650	17.2	13.6	0.79	0.92	20.3	18.7	2.0
	4.5	0.57	1.3	550	26.0	1.28	21.7	113.8	5.98	3.6	3.5	0.38	0.9	500	16.8	12.3	0.73	0.88	19.8	19.2	2.1	
				750	26.3	1.27	22.0	102.5	6.09	3.0				650	17.3	13.7	0.79	0.89	20.4	19.4	2.1	
	5.5	0.90	2.1	550	26.4	1.30	21.9	114.4	5.94	3.8	5.0	0.64	1.5	500	17.1	12.6	0.74	0.87	20.1	19.7	2.2	
				750	26.7	1.29	22.2	102.9	6.05	3.2				650	17.6	14.0	0.80	0.89	20.6	19.9	2.5	
90	3.0	0.24	0.6	550	27.1	1.31	22.6	115.5	6.07	3.6	90	2.5	0.12	0.3	500	15.6	11.3	0.73	1.07	19.2	14.6	2.6
				750	27.3	1.29	22.9	103.7	6.19	2.9					650	16.0	12.5	0.78	1.09	19.7	14.7	2.6
	4.5	0.55	1.3	550	28.4	1.30	24.0	117.9	6.44	3.8	3.5	0.37	0.9	500	15.7	11.4	0.72	1.04	19.2	15.1	2.7	
				750	28.6	1.28	24.3	105.3	6.57	3.2				650	16.1	12.6	0.78	1.06	19.7	15.2	2.7	
	5.5	0.87	2.0	550	28.6	1.32	24.1	118.1	6.34	4.1	5.0	0.61	1.4	500	16.7	12.0	0.72	1.06	20.3	15.8	2.8	
				750	28.7	1.30	24.3	105.4	6.47	3.4				650	16.4	12.9	0.79	1.05	20.0	15.6	2.8	
100	3.0	0.23	0.5	Operation not recommended							100	2.5	0.12	0.3	500	14.5	10.9	0.75	1.29	18.9	11.2	3.1
	4.5	0.53	1.2									3.5	0.35	0.8	500	14.9	12.0	0.81	1.32	19.4	11.3	3.1
	5.5	0.84	1.9									5.0	0.59	1.4	500	14.6	10.9	0.75	1.26	18.9	11.7	3.2
110	3.0	0.22	0.5	Operation not recommended							110	2.5	0.11	0.3	500	15.1	10.4	0.77	1.51	18.6	8.9	3.0
				650	13.8	11.5	0.83	1.54	19.1	9.0					3.0							
	4.5	0.51	1.2								3.5	0.34	0.8	500	13.6	10.5	0.77	1.47	18.6	9.2	3.3	
				650	14.0	11.6	0.83	1.50	19.1	9.3				3.2								
	5.5	0.80	1.9								5.0	0.57	1.3	500	13.8	10.8	0.78	1.46	18.8	9.5	3.4	
				650	14.2	11.9	0.84	1.49	19.3	9.5				3.4								
120	3.0	0.22	0.5	Operation not recommended							120	2.5	0.11	0.2	500	12.6	10.6	0.84	1.93	19.1	6.5	4.3
				650	12.8	11.6	0.90	1.97	19.6	6.5					4.4							
	4.5	0.49	1.1								3.5	0.33	0.8	500	12.7	10.7	0.84	1.82	18.9	7.0	4.4	
				650	12.9	11.6	0.90	1.87	19.3	6.9				4.4								
	5.5	0.77	1.8								5.0	0.55	1.3	500	12.8	10.7	0.83	1.76	18.8	7.3	4.6	
				650	13.1	11.6	0.89	1.82	19.3	7.2				4.6								

Performance capacities shown in thousands of Btuh.

11/2/20

The manufacturer works continually to improve its products. As a result, the design and specifications of each product at the time of order may be changed without notice. Purchaser's approval of this data set signifies that the equipment is acceptable under the provisions of the job specification. Statements and other information contained herein are not express warranties and do not form the basis of any bargain between the parties, but are merely the manufacturer's opinion or commendation of its products.

Contractor: _____ P.O.: _____

Engineer: _____

Project Name: _____ Unit Tag: _____



Performance Data cont.

036 - 100% Full Load

EWT °F	WPD			HEATING - EAT 70°F							EWT °F	WPD			COOLING - EAT 80/67 °F							
	Flow gpm	PSI	FT	Airflow cfm	HC MBtuh	Power kW	HE MBtuh	LAT °F	COP	HWC MBtuh		Flow gpm	PSI	FT	Airflow cfm	TC MBtuh	SC MBtuh	S/T Ratio	Power kW	HR MBtuh	EER	HWC MBtuh
20	5.5	1.09	2.5	Operation not recommended							20	4.5	0.70	1.6	Operation not recommended							
	8.0	2.69	6.2									7.0	1.70	3.9								
	11.5	3.51	8.1	1150	28.0	3.01	17.8	92.6	2.73	4.7		9.0	2.81	6.5	1000	35.0	23.9	0.68	0.96	38.2	36.4	-
30	5.5	1.06	2.5	1150	31.4	2.77	21.9	95.3	3.32	5.2	30	4.5	0.68	1.6	1000	35.6	26.2	0.73	1.00	39.0	35.6	-
				1500	28.9	2.91	19.0	87.8	2.91	4.3					1300	36.0	26.3	0.73	0.96	39.3	37.4	-
	8.0	2.61	6.0	1150	32.2	2.81	22.6	95.9	3.35	5.3		7.0	1.65	3.8	1000	35.4	24.1	0.68	0.91	38.6	38.8	-
				1500	33.1	2.90	23.2	90.5	3.35	4.8		1300	36.0	26.3	0.73	0.96	39.3	37.4	-			
	11.5	3.41	7.9	1150	32.8	3.03	22.5	96.4	3.17	5.4		9.0	2.73	6.3	1000	35.6	24.1	0.68	0.89	38.7	40.2	-
				1500	33.8	2.93	23.8	90.9	3.38	5.0		1300	36.5	26.3	0.72	0.93	39.7	39.2	-			
40	5.5	1.02	2.4	1150	36.3	2.82	26.7	99.2	3.77	5.6	40	4.5	0.66	1.5	1000	37.0	25.7	0.70	1.15	40.9	32.1	-
				1500	37.4	2.89	27.5	93.1	3.79	5.0					1300	37.7	28.1	0.75	1.20	41.8	31.4	-
	8.0	2.53	5.9	1150	37.4	2.88	27.6	100.1	3.82	5.8		7.0	1.60	3.7	1000	37.4	26.0	0.69	1.09	41.1	34.2	-
				1500	38.6	2.94	28.6	93.8	3.85	5.1		1300	38.1	28.4	0.74	1.15	42.0	33.2	-			
	11.5	3.31	7.6	1150	38.2	2.90	28.3	100.7	3.85	5.9		9.0	2.65	6.1	1000	37.7	26.0	0.69	1.06	41.3	35.5	-
				1500	39.4	2.97	29.3	94.3	3.89	5.2		1300	38.6	28.4	0.74	1.11	42.3	34.7	-			
50	5.5	0.99	2.3	1150	41.2	2.87	31.4	103.1	4.21	6.0	50	4.5	0.64	1.5	1000	37.4	25.3	0.68	1.34	41.9	28.0	-
				1500	42.4	2.91	32.5	96.2	4.27	5.6					1300	39.4	28.2	0.72	1.41	44.1	28.0	-
	8.0	2.46	5.7	1150	42.7	2.93	32.7	104.4	4.26	6.5		7.0	1.55	3.6	1000	38.2	25.6	0.67	1.26	42.5	30.3	-
				1500	44.0	2.97	33.9	97.2	4.34	5.7		1300	40.2	28.5	0.71	1.32	44.7	30.4	-			
	11.5	3.20	7.4	1150	43.6	2.96	33.5	105.1	4.32	6.6		9.0	2.56	5.9	1000	38.5	27.4	0.71	1.23	42.7	31.4	-
				1500	45.0	3.00	34.8	97.8	4.40	6.8		1300	40.6	30.4	0.75	1.29	45.0	31.5	-			
60	5.5	0.93	2.2	1150	45.2	2.89	35.4	106.4	4.59	6.1	60	4.5	0.62	1.4	1000	35.9	25.4	0.71	1.53	41.1	23.4	1.9
				1500	46.7	2.91	36.8	98.8	4.70	5.7					1300	37.7	28.3	0.75	1.60	43.1	23.5	2.0
	8.0	2.38	5.5	1150	47.3	2.97	37.1	108.0	4.66	6.7		7.0	1.50	3.5	1000	36.8	25.7	0.70	1.46	41.7	25.2	2.1
				1500	48.8	2.99	38.6	100.1	4.78	5.8		1300	38.5	28.6	0.74	1.52	43.7	25.4	2.1			
	11.5	3.10	7.2	1150	48.4	3.00	38.2	109.0	4.73	6.9		9.0	2.48	5.7	1000	37.1	27.1	0.73	1.42	42.0	26.1	2.0
				1500	50.0	3.02	39.7	100.9	4.86	6.0		1300	39.0	30.1	0.77	1.49	44.0	26.2	2.2			
70	5.5	0.90	2.1	1150	49.3	2.91	39.4	109.7	4.97	6.6	70	4.5	0.60	1.4	1000	34.4	25.6	0.74	1.92	41.0	17.9	2.7
				1500	51.0	3.02	40.7	101.5	4.95	6.2					1300	36.5	29.5	0.81	1.91	43.0	19.1	2.9
	8.0	2.30	5.3	1150	51.9	3.01	41.6	111.8	5.06	6.9		7.0	1.45	3.4	1000	35.3	25.9	0.73	1.66	41.0	21.3	3.1
				1500	53.5	3.01	43.3	103.1	5.22	6.4		1300	36.9	28.7	0.78	1.71	42.7	21.5	3.1			
	11.5	3.00	6.9	1150	53.2	3.04	42.8	112.8	5.12	7.6		9.0	2.40	5.5	1000	35.7	26.9	0.75	1.61	41.2	22.1	3.2
				1500	55.0	3.03	44.7	104.0	5.32	6.6		1300	37.3	29.8	0.80	1.68	43.0	22.2	3.3			
80	5.5	0.87	0.1	1150	52.7	2.96	42.6	112.5	5.21	7.2	80	4.5	0.57	1.3	1000	32.9	25.3	0.77	2.00	39.7	16.5	4.0
				1500	54.6	2.94	44.5	103.7	5.44	6.1					1300	34.2	28.2	0.82	2.06	41.2	16.6	4.0
	8.0	2.22	5.1	1150	55.8	3.08	45.3	114.9	5.31	7.5		7.0	1.40	3.2	1000	33.8	25.6	0.76	1.93	40.4	17.5	4.2
				1500	57.7	3.05	47.3	105.6	5.54	6.3		1300	35.1	28.4	0.81	1.98	41.9	17.7	4.2			
	11.5	2.90	6.7	1150	57.4	3.12	46.7	116.2	5.39	7.7		9.0	2.32	5.4	1000	34.1	26.3	0.77	1.89	40.6	18.1	4.4
				1500	59.4	3.08	48.9	106.6	5.66	7.2		1300	35.6	29.1	0.82	1.95	42.2	18.3	4.4			
90	5.5	0.84	1.9	1150	56.2	3.02	45.9	115.2	5.45	7.4	90	4.5	0.55	1.3	1000	31.3	25.1	0.80	2.27	39.0	13.8	5.3
				1500	58.2	2.97	48.0	105.9	5.74	6.7					1300	32.4	27.9	0.86	2.32	40.3	14.0	5.3
	8.0	2.14	5.0	1150	59.7	3.15	48.9	118.1	5.55	7.8		7.0	1.35	3.1	1000	32.2	25.4	0.79	2.20	39.7	14.6	5.6
				1500	61.8	3.10	51.2	108.2	5.85	7.2		1300	33.4	28.2	0.84	2.26	41.1	14.8	5.6			
	11.5	2.79	6.5	1150	61.6	3.20	50.7	119.6	5.64	8.6		9.0	2.24	5.2	1000	32.8	24.9	0.76	2.17	40.2	15.1	5.9
				1500	63.7	3.12	53.1	109.3	5.98	7.9		1300	33.8	28.4	0.84	2.21	41.3	15.3	5.6			
100	5.5	0.80	1.8	Operation not recommended							100	4.5	0.53	1.2	1000	29.1	24.2	0.83	2.62	38.1	11.1	6.8
				1300	30.0	26.8	0.89	2.67	39.1	11.3					6.7							
	8.0	2.07	4.8									7.0	1.30	3.0	1000	30.1	24.5	0.81	2.57	38.9	11.7	7.1
				1300	31.1	27.2	0.87	2.61	40.0	11.9		7.0										
	11.5	2.69	6.2									9.0	2.16	5.0	1000	30.4	24.4	0.80	2.53	39.0	12.0	7.5
				1300	31.4	27.0	0.86	2.57	40.2	12.2		6.2										
110	5.5	0.77	1.8	Operation not recommended							110	4.5	0.51	1.2	1000	26.9	23.3	0.87	2.98	37.1	9.0	8.1
				1300	27.7	25.8	0.93	3.01	37.9	9.2					8.0							
	8.0	1.99	4.6									7.0	1.25	2.9	1000	27.9	23.5	0.84	2.95	38.0	9.5	8.5
				1300	28.7	26.1	0.91	2.97	38.9	9.7		8.5										
	11.5	2.59	6.0									9.0	2.07	4.8	1000	28.2	23.2	0.82	2.90	38.1	9.7	8.9
				1300	29.0	25.6	0.88	2.93	39.0	9.9		8.1										
120	5.5	0.73	1.7	Operation not recommended							120	4.5	0.49	0.8	1000	23.9	22.7	0.95	3.54	36.0	6.7	9.9
				1300	24.4	24.8	1.02	3.62	36.7	6.7					10.2							
	8.0	1.91	4.4									7.0	1.20	2.8	1000	24.2	22.9	0.95	3.35	35.6	7.2	10.3
				1300	24.6	24.9	1.01	3.43	36.3	7.2		10.5										
	11.5	2.49	5.8									9.0	1.99	4.6	1000	24.4	22.9	0.94	3.24	35.4	7.5	10.7
				1300	24.9	24.9	1.00	3.34	36.3	7.5		10.7										

Performance capacities shown in thousands of Btuh.

11/2/20

The manufacturer works continually to improve its products. As a result, the design and specifications of each product at the time of order may be changed without notice. Purchaser's approval of this data set signifies that the equipment is acceptable under the provisions of the job specification. Statements and other information contained herein are not express warranties and do not form the basis of any bargain between the parties, but are merely the manufacturer's opinion or commendation of its products.

Contractor: _____ P.O.: _____

Engineer: _____

Project Name: _____ Unit Tag: _____



Performance Data cont.

048 - 50% Part Load

EWT °F	WPD			HEATING - EAT 70°F						EWT °F	WPD			COOLING - EAT 80/67 °F															
	Flow gpm	PSI	FT	Airflow cfm	HC mBtuh	Power kW	HE MBtuh	LAT °F	COP		HWC MBtuh	Flow gpm	PSI	FT	Airflow cfm	TC MBtuh	SC MBtuh	S/T Ratio	Power kW	HR MBtuh	EER	HWC MBtuh							
20	3.5	0.56	1.3	Operation not recommended						20	3.0	0.47	1.1	Operation not recommended															
	5.0	0.97	2.2	650	16.5	1.83	10.3	93.6	2.65		2.4	4.5	0.81	1.9	500	23.9	14.1	0.59	0.57	25.8	42.0	-							
	6.5	1.37	3.2	900	16.9	1.65	11.3	87.4	3.00		3.1	6.0	1.16	2.7	750	24.3	15.5	0.64	0.59	26.3	41.1	-							
30	3.5	0.55	1.3	650	16.7	1.57	11.4	93.9	3.12	2.7	30	3.0	0.45	1.1	500	23.9	14.1	0.59	0.57	25.8	42.0	-							
				900	17.3	1.60	11.9	87.8	3.17	2.4					750	24.3	15.5	0.64	0.59	26.3	41.1	-							
	5.0	0.94	2.2	650	18.1	1.64	12.5	95.8	3.22	3.0		4.5	0.79	1.8	500	24.2	14.3	0.59	0.54	26.0	44.8	-							
				900	18.6	1.66	13.0	89.2	3.30	2.6					750	24.6	15.6	0.63	0.57	26.5	43.2	-							
	6.5	1.33	3.1	650	18.8	1.86	12.5	96.8	2.96	3.1		6.0	1.12	2.6	500	24.3	14.3	0.59	0.52	26.1	46.4	-							
				900	19.2	1.68	13.5	89.8	3.35	2.6					750	24.9	15.6	0.63	0.55	26.8	45.3	-							
40	3.5	0.53	1.2	650	19.8	1.61	14.3	98.3	3.61	3.0	40	3.0	0.44	1.0	500	27.0	18.1	0.67	0.49	28.6	55.3	-							
				900	20.5	1.62	14.9	91.1	3.70	2.6					750	27.5	19.7	0.72	0.51	29.2	54.1	-							
	5.0	0.91	2.1	650	21.4	1.67	15.7	100.5	3.75	3.3		4.5	0.77	1.8	500	27.3	18.2	0.67	0.46	28.9	58.9	-							
				900	22.1	1.67	16.4	92.8	3.88	2.8					750	27.8	19.9	0.72	0.49	29.4	57.2	-							
	6.5	1.29	3.0	650	22.1	1.68	16.4	101.5	3.85	3.4		6.0	1.09	2.5	500	27.5	18.2	0.66	0.45	29.0	61.2	-							
				900	22.9	1.70	17.1	93.5	3.95	2.8					750	28.1	19.9	0.71	0.47	29.7	59.8	-							
50	3.5	0.51	1.2	650	22.9	1.65	17.3	102.7	4.08	3.3	50	3.0	0.43	1.0	500	25.8	16.3	0.63	0.68	28.1	38.1	-							
				900	23.7	1.65	18.0	94.3	4.21	2.8					750	26.6	19.2	0.72	0.71	29.0	37.7	-							
	5.0	0.88	2.0	650	24.7	1.70	18.9	105.2	4.26	3.6		4.5	0.74	1.7	500	26.3	16.4	0.62	0.59	28.3	45.0	-							
				900	25.7	1.69	19.9	96.4	4.45	3.0					750	27.1	19.3	0.71	0.61	29.2	44.2	-							
	6.5	1.25	2.9	650	25.7	1.71	19.8	106.6	4.40	3.8		6.0	1.06	2.4	500	26.5	16.4	0.62	0.55	28.4	48.0	-							
				900	26.5	1.71	20.7	97.3	4.54	3.3					750	27.3	19.3	0.71	0.58	29.3	47.1	-							
60	3.5	0.50	1.1	650	25.7	1.71	19.9	106.6	4.41	3.7	60	3.0	0.41	1.0	500	24.7	15.9	0.64	0.83	27.6	29.8	1.2							
				900	26.7	1.70	20.9	97.4	4.60	3.0					750	25.5	18.7	0.73	0.87	28.5	29.5	1.2							
	5.0	0.85	2.0	650	27.8	1.75	21.9	109.7	4.66	3.9		4.5	0.72	1.7	500	25.1	16.0	0.64	0.74	27.7	34.2	1.3							
				900	28.9	1.73	23.0	99.8	4.90	3.3					750	25.9	18.9	0.73	0.77	28.5	33.6	1.3							
	6.5	1.21	2.8	650	29.0	1.77	23.0	111.3	4.82	4.1		6.0	1.02	2.4	500	25.4	16.1	0.63	0.70	27.8	36.4	1.4							
				900	30.1	1.75	24.1	100.9	5.05	3.5					750	26.2	18.9	0.72	0.73	28.7	35.9	1.4							
70	3.5	0.48	1.1	650	28.5	1.77	22.5	110.7	4.73	4.0	70	3.0	0.40	0.9	500	23.7	15.5	0.65	0.98	27.0	24.2	1.7							
				900	31.1	1.77	25.1	102.0	5.15	3.3					750	24.6	18.3	0.74	1.03	28.1	23.9	1.8							
	5.0	0.83	1.9	650	31.0	1.80	24.8	114.1	5.04	4.3		4.5	0.70	1.6	500	23.9	15.7	0.65	0.89	27.0	27.0	1.9							
				900	32.2	1.77	26.1	103.1	5.33	3.6					750	24.7	18.4	0.75	0.93	27.8	26.7	1.9							
	6.5	1.17	2.7	650	32.4	1.82	26.2	116.1	5.21	4.5		6.0	0.99	2.3	500	24.4	15.8	0.65	0.85	27.2	28.7	1.9							
				900	33.6	1.78	27.5	104.6	5.53	3.7					750	25.1	18.5	0.74	0.88	28.1	28.5	2.0							
80	3.5	0.46	1.1	650	30.5	1.87	24.1	113.4	4.78	4.2	80	3.0	0.39	0.9	500	22.6	15.0	0.66	1.16	26.5	19.5	2.5							
				900	31.6	1.83	25.4	102.6	5.06	3.5					750	23.3	17.6	0.76	1.21	27.4	19.3	2.5							
	5.0	0.80	1.8	650	33.1	1.89	26.6	117.1	5.14	4.5		4.5	0.67	1.6	500	22.7	15.2	0.67	1.07	26.3	21.1	2.6							
				900	34.4	1.84	28.1	105.4	5.48	3.8					750	23.4	17.8	0.76	1.12	27.2	20.9	2.7							
	6.5	1.13	2.6	650	34.8	1.91	28.3	119.5	5.34	4.8		6.0	0.96	2.2	500	23.2	15.3	0.66	1.03	26.7	22.6	2.8							
				900	36.2	1.86	29.8	107.2	5.71	4.0					750	23.9	18.0	0.75	1.07	27.6	22.3	3.2							
90	3.5	0.45	1.0	650	32.4	1.96	25.7	116.1	4.84	4.5	90	3.0	0.37	0.9	500	21.4	14.5	0.68	1.33	26.0	16.1	3.4							
				900	33.6	1.92	27.1	104.6	5.14	3.7					750	22.1	17.0	0.77	1.38	26.8	16.0	3.4							
	5.0	0.77	1.8	650	35.2	1.97	28.5	120.1	5.23	4.8		4.5	0.65	1.5	500	21.4	14.6	0.68	1.26	25.7	17.0	3.5							
				900	36.7	1.91	30.1	107.7	5.63	4.0					750	22.0	17.2	0.78	1.31	26.5	16.9	3.6							
	6.5	1.09	2.5	650	37.1	1.99	30.3	122.9	5.46	5.2		6.0	0.92	2.1	500	20.5	13.8	0.67	1.27	24.8	16.1	3.7							
				900	38.7	1.93	32.1	109.8	5.88	4.3					750	22.7	17.4	0.77	1.26	27.0	18.0	3.7							
100	3.5	0.43	1.0	Operation not recommended						100	3.0	0.36	0.8	500	19.3	13.3	0.69	1.56	24.6	12.4	4.3								
														750	19.9	15.6	0.78	1.62	25.5	12.3	4.3								
	5.0	0.74	1.7								500	19.2	13.4	0.70	1.52	24.4	12.7	4.4	4.5	0.62	1.4	750	19.8	15.8	0.80	1.58	25.2	12.6	4.4
											500	19.9	13.6	0.68	1.46	24.9	13.6	4.6											
	6.5	1.05	2.4								750	20.5	16.0	0.78	1.53	25.7	13.4	4.6	6.0	0.89	2.1	500	17.2	12.1	0.70	1.78	23.3	9.7	5.0
											750	17.7	14.2	0.80	1.85	24.1	9.6	5.0											
110	3.5	0.41	1.0	Operation not recommended						110	3.0	0.35	0.8	500	17.0	12.2	0.72	1.77	23.0	9.6	5.4								
														750	17.6	14.4	0.82	1.85	23.9	9.5	5.4								
	5.0	0.71	1.6								500	17.8	12.4	0.70	1.72	23.7	10.4	5.8	4.5	0.60	1.4	750	18.3	14.6	0.80	1.79	24.4	10.2	5.8
											500	16.0	12.8	0.80	2.22	23.6	7.2	6.4											
	6.5	1.01	2.3								750	16.4	13.9	0.85	2.27	24.1	7.2	6.5	6.0	0.86	2.0	500	16.2	12.9	0.80	2.09	23.4	7.7	6.6
											750	16.5	14.0	0.85	2.15	23.8	7.7	6.6											
120	3.5	0.40	0.9	Operation not recommended						120	3.0	0.33	0.8	500	16.4	12.9	0.79	2.03	23.3	8.1	6.8								
														750	16.7	14.0	0.84	2.09	23.8	8.0	6.8								
	5.0	0.68	1.6								500	16.0	12.8	0.80	2.22	23.6	7.2	6.4	4.5	0.58	1.3	750	16.4	13.9	0.85	2.27	24.1	7.2	6.5
											500	16.2	12.9	0.80	2.09	23.4	7.7	6.6											
	6.5	0.97	2.2								750	16.5	14.0	0.85	2.15	23.8	7.7	6.6	6.0	0.82	1.9	500	16.4	12.9	0.79	2.03	23.3	8.1	6.8
											750	16.7	14.0	0.84	2.09	23.8	8.0	6.8											

Performance capacities shown in thousands of Btuh.

11/2/20

The manufacturer works continually to improve its products. As a result, the design and specifications of each product at the time of order may be changed without notice. Purchaser's approval of this data set signifies that the equipment is acceptable under the provisions of the job specification. Statements and other information contained herein are not express warranties and do not form the basis of any bargain between the parties, but are merely the manufacturer's opinion or commendation of its products.

Contractor: _____ P.O.: _____

Engineer: _____

Project Name: _____ Unit Tag: _____



Performance Data cont.

048 - 100% Full Load

EWT °F	Flow gpm	WPD		HEATING - EAT 70°F							EWT °F	Flow gpm	WPD		COOLING - EAT 80/67 °F							
		PSI	FT	Airflow cfm	HC mBtuh	Power kW	HE MBtuh	LAT °F	COP	HWC MBtuh			PSI	FT	Airflow cfm	TC MBtuh	SC MB- tuh	S/T Ratio	Power kW	HR MBtuh	EER	HWC MBtuh
20	6.5	1.40	3.2	Operation not recommended							20	5.5	1.05	2.4	Operation not recommended							
	10.0	2.85	6.6									8.0	2.00	4.6								
	13.5	4.79	11.1	1500	39.4	4.05	25.6	94.3	2.86	6.05		10.5	2.94	6.8								
30	6.5	1.36	3.2	1500	39.9	3.84	26.7	94.6	3.04	6.6	30	5.5	1.02	2.4	1000	42.8	28.0	0.65	1.20	46.9	35.7	-
				1800	41.2	3.90	27.9	91.2	3.10	6.1		8.0	1.94	4.5	1400	43.6	30.8	0.70	1.25	47.9	35.0	-
	10.0	2.77	6.4	1500	43.0	4.01	29.3	96.6	3.14	6.8		1000	43.4	28.3	0.65	1.14	47.3	38.1	-			
40	6.5	1.32	3.1	1500	45.4	4.18	31.1	98.0	3.18	6.9	40	5.5	0.99	2.3	1000	44.7	29.0	0.65	1.42	49.5	31.4	-
				1800	45.7	4.10	31.7	93.5	3.27	6.3		8.0	1.88	4.3	1400	44.7	30.9	0.69	1.16	48.7	38.5	-
	10.0	2.69	6.2	1500	49.0	4.15	34.9	100.3	3.46	7.3		1000	45.2	29.2	0.65	1.35	49.8	33.5	-			
50	6.5	1.28	3.0	1500	50.7	4.15	36.6	96.1	3.58	6.4	50	5.5	0.96	2.2	1000	45.5	29.2	0.64	1.31	50.0	34.8	-
				1800	50.6	4.18	36.4	101.2	3.55	7.5		8.0	2.77	6.4	1400	46.6	31.9	0.69	1.37	51.2	34.0	-
	10.0	2.60	6.0	1500	51.0	4.15	36.9	101.5	3.61	7.5		1000	45.7	27.8	0.61	1.84	52.0	24.8	-			
60	6.5	1.24	2.9	1500	52.4	4.21	38.0	96.9	3.65	6.5	60	5.5	0.92	2.2	1000	47.1	32.8	0.70	1.92	53.7	24.5	-
				1800	52.4	4.21	38.0	96.9	3.65	6.5		8.0	1.82	4.2	1400	46.7	27.9	0.60	1.60	52.1	29.3	-
	10.0	2.44	5.8	1500	57.1	4.26	42.6	99.4	3.93	7.2		1000	47.0	27.9	0.59	1.50	52.1	31.3	-			
70	6.5	1.20	2.8	1500	57.1	4.32	42.3	105.2	3.87	7.6	70	5.5	0.93	2.2	1000	48.4	32.9	0.68	1.67	53.8	28.8	-
				1800	59.1	4.29	44.5	100.4	4.04	7.1		8.0	1.76	4.1	1400	45.2	32.1	0.71	2.15	52.6	21.1	2.8
	10.0	2.52	5.8	1500	61.7	4.42	46.7	108.1	4.09	8.4		1000	44.6	27.4	0.62	1.83	50.8	24.4	2.9			
80	6.5	1.16	2.7	1500	64.4	4.46	49.1	109.7	4.23	8.6	80	5.5	0.87	2.0	1000	45.9	32.3	0.70	1.91	52.5	24.1	2.9
				1800	66.7	4.41	51.6	104.3	4.43	7.4		8.0	1.65	3.8	1400	45.1	27.5	0.61	1.73	51.0	26.0	2.8
	10.0	2.35	5.4	1500	68.5	4.56	52.9	112.3	4.40	8.6		1000	46.5	32.4	0.70	1.81	52.6	25.7	3.0			
90	6.5	1.12	2.6	1500	71.2	4.48	55.9	106.6	4.65	7.9	90	5.5	0.90	2.1	1000	46.5	32.4	0.70	1.81	52.6	25.7	3.0
				1800	71.2	4.48	55.9	106.6	4.65	7.9		8.0	1.71	3.9	1400	42.0	26.7	0.63	2.27	49.7	18.5	3.4
	10.0	2.27	5.2	1500	73.5	4.93	56.7	115.4	4.37	9.7		1000	43.7	31.7	0.73	2.27	51.4	19.3	3.7			
100	6.5	1.04	2.4	1500	74.3	4.82	60.0	109.3	4.64	8.6	100	5.5	0.84	1.9	1000	43.8	31.7	0.72	2.15	51.1	20.4	3.9
				1800	76.4	4.82	60.0	109.3	4.64	8.6		8.0	1.71	3.9	1400	43.8	31.7	0.72	2.15	51.1	20.4	3.9
	10.0	2.27	5.2	1500	77.2	4.64	61.4	109.7	4.88	7.9		1000	43.2	27.1	0.63	1.96	49.9	22.0	3.9			
110	6.5	1.00	2.3	1500	77.2	4.64	61.4	109.7	4.88	7.9	110	5.5	0.81	1.9	1000	44.5	31.8	0.71	2.04	51.5	21.8	4.1
				1800	81.1	4.68	65.1	111.7	5.08	9.0		8.0	2.42	5.6	1400	44.5	31.8	0.71	2.04	51.5	21.8	4.1
	10.0	2.11	4.9	1500	84.4	5.01	67.3	122.1	4.93	10.4		1000	39.8	29.8	0.75	2.67	48.9	14.9	7.4			
120	6.5	1.00	2.3	1500	84.4	5.01	67.3	122.1	4.93	10.4	120	5.5	0.75	1.7	1000	37.6	24.8	0.66	2.82	47.2	13.3	6.7
				1800	87.9	4.85	71.4	115.2	5.31	9.7		8.0	1.59	3.7	1400	38.8	29.1	0.75	2.93	48.7	13.2	6.6
	10.0	2.02	4.7	1500	87.9	4.85	71.4	115.2	5.31	9.7		1000	37.6	25.1	0.67	2.67	46.7	14.1	7.0			
130	6.5	1.08	2.5	1500	88.3	4.80	66.9	122.8	5.09	8.9	130	5.5	0.84	1.9	1000	38.6	29.5	0.76	2.77	48.0	14.0	7.0
				1800	84.4	5.01	67.3	122.1	4.93	10.4		8.0	2.34	5.4	1400	37.3	24.9	0.67	2.59	46.1	14.4	7.3
	10.0	2.02	4.7	1500	87.9	4.85	71.4	115.2	5.31	9.7		1000	39.8	29.8	0.75	2.67	48.9	14.9	7.4			
140	6.5	1.04	2.4	1500	88.3	4.80	66.9	122.8	5.09	8.9	140	5.5	0.81	1.9	1000	35.1	23.9	0.68	3.14	45.8	11.2	8.9
				1800	87.9	4.85	71.4	115.2	5.31	9.7		8.0	1.53	3.5	1400	36.2	28.1	0.78	3.27	47.3	11.1	8.8
	10.0	2.11	4.9	1500	88.3	4.80	66.9	122.8	5.09	8.9		1000	34.9	24.2	0.69	3.05	45.3	11.4	9.3			
150	6.5	1.04	2.4	1500	88.3	4.80	66.9	122.8	5.09	8.9	150	5.5	0.78	1.8	1000	36.0	28.5	0.79	3.17	46.8	11.3	9.2
				1800	88.3	4.80	66.9	122.8	5.09	8.9		8.0	1.47	3.4	1400	36.2	24.6	0.68	2.94	46.2	12.3	9.8
	10.0	2.11	4.9	1500	88.3	4.80	66.9	122.8	5.09	8.9		1000	33.8	23.8	0.70	3.33	45.1	10.1	11.6			
160	6.5	1.04	2.4	1500	88.3	4.80	66.9	122.8	5.09	8.9	160	5.5	0.75	1.7	1000	34.7	27.9	0.80	3.47	46.5	10.0	10.5
				1800	88.3	4.80	66.9	122.8	5.09	8.9		8.0	1.42	3.3	1400	34.7	27.9	0.80	3.47	46.5	10.0	10.5
	10.0	2.02	4.7	1500	88.3	4.80	66.9	122.8	5.09	8.9		1000	30.9	24.4	0.79	4.15	45.0	7.4	12.8			
170	6.5	1.00	2.3	1500	88.3	4.80	66.9	122.8	5.09	8.9	170	5.5	0.75	1.7	1000	31.5	26.6	0.84	4.25	46.0	7.4	13.1
				1800	88.3	4.80	66.9	122.8	5.09	8.9		8.0	1.42	3.3	1400	31.3	24.6	0.79	3.93	44.7	8.0	13.2
	10.0	2.02	4.7	1500	88.3	4.80	66.9	122.8	5.09	8.9		1000	31.8	26.7	0.84	4.03	45.6	7.9	13.6			
180	6.5	1.00	2.3	1500	88.3	4.80	66.9	122.8	5.09	8.9	180	5.5	0.75	1.7	1000	31.5	24.6	0.78	3.80	44.5	8.3	13.8
				1800	88.3	4.80	66.9	122.8	5.09	8.9		8.0	1.42	3.3	1400	31.5	24.6	0.78	3.80	44.5	8.3	13.8
	10.0	2.02	4.7	1500	88.3	4.80	66.9	122.8	5.09	8.9		1000	32.2	26.7	0.83	3.92	45.6	8.2	14.0			

Performance capacities shown in thousands of Btuh.

11/2/20

The manufacturer works continually to improve its products. As a result, the design and specifications of each product at the time of order may be changed without notice. Purchaser's approval of this data set signifies that the equipment is acceptable under the provisions of the job specification. Statements and other information contained herein are not express warranties and do not form the basis of any bargain between the parties, but are merely the manufacturer's opinion or commendation of its products.

Contractor: _____ P.O.: _____

Engineer: _____

Project Name: _____ Unit Tag: _____



Performance Data cont.

060 - 50% Part Load

EWT °F	Flow gpm	WPD		HEATING - EAT 70°F							EWT °F	Flow gpm	WPD		COOLING - EAT 80/67 °F							
		PSI	FT	Airflow cfm	HC mBtuh	Power kW	HE MBtuh	LAT °F	COP	HWC MBtuh			PSI	FT	Airflow cfm	TC MBtuh	SC MBtuh	S/T Ratio	Power kW	HR MBtuh	EER	HWC MBtuh
20	4.5	0.63	1.5	Operation not recommended							20	4.0	0.43	1.0	Operation not recommended							
	6.3	1.17	2.7									6.0	1.22	2.8								
	8.5	1.94	4.5	850	21.0	2.18	13.5	92.9	2.82	3.4		1100	21.4	2.02	14.5	88.0	3.10	3.1				
30	4.5	0.61	1.4	850	23.8	2.01	16.9	95.9	3.47	3.9	30	4.0	0.42	1.0	700	31.5	18.0	0.57	0.76	34.1	41.2	-
				1100	24.6	2.03	17.7	90.7	3.54	3.4					950	32.1	19.7	0.61	0.80	34.8	40.3	-
	6.3	1.14	2.6	850	23.6	2.03	16.7	95.7	3.40	4.1	6.0	1.18	2.7	700	32.0	18.1	0.57	0.73	34.4	44.0	-	
				1100	24.5	2.06	17.4	90.6	3.48	3.5				950	32.5	19.8	0.61	0.77	35.1	42.4	-	
	8.5	1.89	4.4	850	24.8	2.22	17.2	97.0	3.27	4.2	7.5	1.75	4.0	700	32.1	18.1	0.56	0.70	34.5	45.6	-	
1100	25.3	2.06	18.3	91.3	3.60	3.6	950	32.9	19.8	0.60				0.74	35.4	44.5	-					
40	4.5	0.60	1.4	850	27.5	2.05	20.5	100.0	3.94	4.3	40	4.0	0.41	0.9	700	32.5	20.5	0.63	0.81	35.3	39.9	-
				1100	28.4	2.06	21.3	93.9	4.03	3.7					950	33.2	22.4	0.68	0.85	36.1	39.1	-
	6.3	1.10	2.5	850	27.7	2.08	20.6	100.2	3.90	4.5	6.0	1.15	2.6	700	32.9	20.7	0.63	0.77	35.5	42.5	-	
				1100	28.5	2.09	21.4	94.0	4.00	3.8				950	33.5	22.6	0.67	0.81	36.3	41.3	-	
	8.5	1.83	4.2	850	28.6	2.09	21.5	101.2	4.02	4.7	7.5	1.70	3.9	700	33.2	20.7	0.62	0.75	35.7	44.2	-	
1100				29.4	2.10	22.3	94.7	4.11	3.9	950				33.9	22.6	0.67	0.79	36.6	43.2	-		
50	4.5	0.58	1.3	850	31.3	2.09	24.2	104.1	4.39	4.7	50	4.0	0.40	0.9	700	33.7	22.2	0.66	0.84	36.6	40.3	-
				1100	32.2	2.09	25.0	97.1	4.51	3.9					950	34.7	25.2	0.73	0.88	37.7	39.3	-
	6.3	1.07	2.5	850	31.8	2.13	24.5	104.6	4.38	4.9	6.0	1.11	2.6	700	33.8	22.4	0.66	0.81	36.6	41.9	-	
				1100	32.5	2.12	25.3	97.4	4.50	4.1				950	34.8	25.4	0.73	0.85	37.7	41.2	-	
	8.5	1.77	4.1	850	32.8	2.14	25.5	105.7	4.48	5.2	7.5	1.64	3.8	700	33.9	22.4	0.66	0.79	36.6	42.8	-	
1100	33.5	2.13	26.2	98.2	4.61	4.6	950	34.9	25.4	0.73				0.83	37.7	42.0	-					
60	4.5	0.56	1.3	850	35.3	2.13	28.0	108.5	4.86	5.1	60	4.0	0.38	0.9	700	32.7	21.9	0.67	1.03	36.2	31.8	1.5
				1100	36.1	2.11	28.9	100.4	5.01	4.2					950	33.7	24.7	0.73	1.08	37.4	31.3	1.6
	6.3	1.03	2.4	850	36.4	2.17	29.0	109.7	4.92	5.3	6.0	1.08	2.5	700	32.9	22.1	0.67	1.00	36.3	33.0	1.7	
				1100	37.0	2.14	29.7	101.1	5.07	4.5				950	33.9	25.0	0.74	1.04	37.4	32.5	1.7	
	8.5	1.72	4.0	850	37.3	2.19	29.8	110.6	5.00	5.6	7.5	1.59	3.7	700	33.0	22.1	0.67	0.98	36.3	33.9	1.8	
1100	37.9	2.16	30.5	101.9	5.15	4.7	950	34.0	25.0	0.74				1.02	37.5	33.3	1.8					
70	4.5	0.54	1.2	850	39.3	2.17	31.9	112.8	5.31	5.4	70	4.0	0.37	0.9	700	31.7	21.6	0.68	1.22	35.9	26.0	2.1
				1100	38.6	2.15	31.3	102.5	5.26	4.5					950	33.0	24.7	0.75	1.39	37.7	23.7	2.3
	6.3	1.00	2.3	850	41.0	2.20	33.5	114.6	5.45	5.8	6.0	1.04	2.4	700	31.9	21.8	0.68	1.18	36.0	27.0	2.4	
				1100	41.4	2.16	34.1	104.9	5.63	4.8				950	32.9	24.5	0.74	1.24	37.1	26.6	2.4	
	8.5	1.66	3.8	850	41.8	2.23	34.1	115.5	5.49	6.0	7.5	1.54	3.6	700	32.1	21.9	0.68	1.16	36.1	27.7	2.5	
1100				42.2	2.18	34.8	105.5	5.67	5.0	950				33.1	24.6	0.74	1.21	37.2	27.4	2.5		
80	4.5	0.52	1.2	850	42.9	2.23	35.3	116.7	5.64	5.8	80	4.0	0.36	0.8	700	29.9	21.2	0.71	1.45	34.8	20.6	3.1
				1100	43.3	2.18	35.8	106.4	5.81	4.8					950	30.8	23.6	0.77	1.50	35.9	20.5	3.2
	6.3	0.97	2.2	850	45.3	2.27	37.6	119.3	5.86	6.2	6.0	1.00	2.3	700	30.1	21.4	0.71	1.41	35.0	21.3	3.3	
				1100	45.5	2.20	38.0	108.3	6.06	5.1				950	31.0	23.9	0.77	1.47	36.1	21.2	3.4	
	8.5	1.60	3.7	850	45.8	2.30	38.0	119.9	5.85	6.6	7.5	1.49	3.4	700	30.3	21.5	0.71	1.39	35.1	21.8	3.5	
1100				46.0	2.23	38.4	108.7	6.05	5.4	950				31.3	24.1	0.77	1.44	36.2	21.7	4.0		
90	4.5	0.50	1.2	850	46.5	2.29	38.6	120.6	5.94	6.2	90	4.0	0.34	0.8	700	28.0	20.7	0.74	1.68	33.8	16.7	4.4
				1100	46.6	2.23	39.0	109.2	6.12	5.0					950	28.9	23.0	0.80	1.73	34.8	16.7	4.4
	6.3	0.93	2.2	850	49.6	2.33	41.6	124.0	6.24	6.6	6.0	0.97	2.2	700	28.4	20.9	0.74	1.64	34.0	17.3	4.6	
				1100	49.6	2.24	41.9	111.7	6.48	5.4				950	29.2	23.3	0.80	1.70	35.0	17.2	4.6	
	8.5	1.55	3.6	850	49.9	2.36	41.8	124.4	6.19	7.1	7.5	1.43	3.3	700	28.2	19.4	0.69	1.67	33.9	16.9	4.8	
1100				49.8	2.28	42.0	111.9	6.40	5.8	950				29.5	23.5	0.80	1.67	35.2	17.7	4.8		
100	4.5	0.48	1.1	Operation not recommended							100	4.0	0.33	0.8	700	26.1	20.1	0.77	2.02	33.0	12.9	5.4
	6.3	0.90	2.1									6.0	0.93	2.2	700	26.4	20.3	0.77	1.99	33.2	13.3	5.5
	8.5	1.49	3.4									7.5	1.38	3.2	700	27.2	22.5	0.83	2.04	34.2	13.3	5.5
110	4.5	0.47	1.1	Operation not recommended							110	4.0	0.32	0.7	700	24.2	19.6	0.81	2.36	32.2	10.2	6.3
				950	24.9	21.5	0.86	2.41	33.2	10.4					6.3							
	6.3	0.86	2.0								6.0	0.90	2.1	700	24.5	19.8	0.81	2.34	32.5	10.5	6.8	
				950	25.3	21.7	0.86	2.38	33.4	10.6				6.8								
	8.5	1.43	3.3								7.5	1.33	3.1	700	24.8	20.1	0.81	2.30	32.7	10.8	7.2	
950				25.6	22.0	0.86	2.35	33.6	10.9	7.2												
120	4.5	0.45	1.0	Operation not recommended							120	4.0	0.31	0.7	700	23.6	19.3	0.82	2.88	33.4	8.2	8.2
				950	24.1	21.0	0.87	2.95	34.2	8.2					8.2							
	6.3	0.83	1.9								6.0	0.86	2.0	700	23.9	19.4	0.81	2.73	33.2	8.8	8.4	
				950	24.3	21.1	0.87	2.80	33.8	8.7				8.4								
	8.5	1.38	3.2								7.5	1.28	3.0	700	24.1	19.4	0.81	2.64	33.1	9.1	8.7	
950				24.6	21.1	0.86	2.72	33.9	9.0	8.7												

Performance capacities shown in thousands of Btuh.

11/2/20

The manufacturer works continually to improve its products. As a result, the design and specifications of each product at the time of order may be changed without notice. Purchaser's approval of this data set signifies that the equipment is acceptable under the provisions of the job specification. Statements and other information contained herein are not express warranties and do not form the basis of any bargain between the parties, but are merely the manufacturer's opinion or commendation of its products.

Contractor: _____ P.O.: _____

Engineer: _____

Project Name: _____ Unit Tag: _____



Performance Data cont.

060 - 100% Full Load

EWT °F	Flow gpm	WPD		HEATING - EAT 70°F							EWT °F	Flow gpm	WPD		COOLING - EAT 80/67 °F															
		PSI	FT	Airflow cfm	HC mBtuh	Power kW	HE MBtuh	LAT °F	COP	HWC MBtuh			PSI	FT	Airflow cfm	TC MBtuh	SC MBtuh	S/T Ratio	Power kW	HR MBtuh	EER	HWC MBtuh								
20	8.5	2.00	4.6	Operation not recommended							20	6.5	1.21	2.8	Operation not recommended															
	13.0	3.52	8.1									10.0	2.70	6.2																
	17.0	6.55	15.1	1800	47.9	5.26	29.9	94.6	2.67	8.1		13.5	4.20	9.7	1500	59.6	37.0	0.62	1.75	65.5	34.1	-								
30	8.5	1.95	4.5	1800	48.2	4.41	33.2	94.8	3.21	8.4	30	6.5	1.17	2.7	1500	60.7	40.6	0.67	1.82	66.9	33.4	-								
				2200	49.4	4.64	33.5	90.8	3.12	7.8					1800	60.4	37.3	0.62	1.66	66.1	36.4	-								
	13.0	3.42	7.9	1800	51.6	4.45	36.4	96.6	3.40	8.6		10.0	2.62	6.1	1500	61.4	40.8	0.66	1.75	67.3	35.1	-								
				2200	53.0	4.74	36.9	92.3	3.28	7.9		1800	60.7	37.3	0.61	1.61	66.2	37.7	-											
	17.0	6.36	14.7	1800	52.5	4.81	36.1	97.0	3.20	8.8		13.5	4.08	9.4	1500	62.2	40.8	0.66	1.69	68.0	36.8	-								
				2200	53.6	4.78	37.3	92.6	3.29	8.0		1800	62.2	40.8	0.66	1.69	68.0	36.8	-											
40	8.5	1.90	4.4	1800	56.0	4.58	40.4	98.8	3.58	8.9	40	6.5	1.14	2.6	1500	60.6	39.5	0.65	2.04	67.5	29.7	-								
				2200	57.3	4.77	41.0	94.1	3.52	8.2					1800	61.8	43.2	0.70	2.12	69.0	29.1	-								
	13.0	3.32	7.7	1800	59.6	4.65	43.7	100.6	3.75	9.2		10.0	2.55	5.9	1500	61.3	39.9	0.65	1.94	67.9	31.7	-								
				2200	60.9	4.85	44.4	95.6	3.68	8.4		1800	62.4	43.5	0.70	2.03	69.4	30.7	-											
	17.0	6.17	14.3	1800	60.5	4.74	44.3	101.1	3.74	9.5		13.5	3.96	9.1	1500	61.8	39.9	0.65	1.88	68.2	32.9	-								
				2200	61.9	4.90	45.1	96.0	3.70	8.6		1800	63.2	43.5	0.69	1.97	69.9	32.1	-											
50	8.5	1.85	4.3	1800	63.8	4.75	47.6	102.8	3.93	9.5	50	6.5	1.10	2.5	1500	61.6	41.7	0.68	2.19	69.1	28.1	-								
				2200	65.2	4.90	48.4	97.4	3.90	8.6					1800	62.8	45.3	0.72	2.33	70.8	27.0	-								
	13.0	3.21	7.4	1800	67.5	4.85	51.0	104.7	4.08	9.9		10.0	2.47	5.7	1500	62.2	42.1	0.68	2.14	69.5	29.0	-								
				2200	68.9	4.97	51.9	99.0	4.06	8.9		1800	63.5	45.8	0.72	2.28	71.2	27.9	-											
	17.0	5.98	13.8	1800	68.6	4.90	51.9	105.3	4.10	10.3		13.5	3.83	8.9	1500	62.8	42.6	0.68	2.11	70.0	29.8	-								
				2200	70.1	5.02	53.0	99.5	4.09	9.3		1800	64.1	46.2	0.72	2.24	71.7	28.6	-											
60	8.5	1.80	4.2	1800	72.5	4.94	55.7	107.3	4.30	10.1	60	6.5	1.07	2.5	1500	59.2	40.9	0.69	2.46	67.6	24.0	3.1								
				2200	74.1	5.02	57.0	101.2	4.33	9.0					1800	60.7	44.4	0.73	2.62	69.6	23.1	3.1								
	13.0	3.11	7.2	1800	75.9	5.02	58.7	109.0	4.43	10.6		10.0	2.39	5.5	1500	59.8	41.3	0.69	2.42	68.0	24.7	2.9								
				2200	77.5	5.08	60.1	102.6	4.47	9.5		1800	61.3	44.9	0.73	2.57	70.1	23.9	2.9											
	17.0	5.79	13.4	1800	77.5	5.08	60.2	109.9	4.47	11.1		13.5	3.71	8.6	1500	60.4	41.7	0.69	2.37	68.5	25.4	2.7								
				2200	79.3	5.14	61.7	103.4	4.52	9.9		1800	61.9	45.3	0.73	2.53	70.5	24.5	2.7											
70	8.5	1.75	4.0	1800	81.3	5.12	63.8	111.8	4.65	10.6	70	6.5	1.03	2.4	1500	56.7	40.1	0.71	2.74	66.1	20.7	4.6								
				2200	81.5	5.15	63.9	104.3	4.64	9.5					1800	58.1	44.0	0.76	3.20	69.0	18.2	4.6								
	13.0	3.01	7.0	1800	84.2	5.19	66.5	113.3	4.76	11.2		10.0	2.31	5.3	1500	57.3	40.5	0.71	2.69	66.5	21.3	4.3								
				2200	86.1	5.20	68.4	106.3	4.85	10.0		1800	59.1	43.9	0.74	2.86	68.9	20.7	4.3											
	17.0	5.60	12.9	1800	86.4	5.25	68.5	114.4	4.82	11.9		13.5	3.59	8.3	1500	57.8	40.8	0.71	2.64	66.9	21.9	4.2								
				2200	88.4	5.25	70.5	107.2	4.93	10.6		1800	59.7	44.4	0.74	2.81	69.3	21.2	4.1											
80	8.5	1.68	3.9	1800	90.5	5.41	72.1	116.6	4.90	11.8	80	6.5	0.99	2.3	1500	52.9	38.8	0.73	3.13	63.6	16.9	6.1								
				2200	92.6	5.38	74.2	109.0	5.05	9.9					1800	54.9	42.2	0.77	3.34	66.3	16.4	6.1								
	13.0	2.91	6.7	1800	92.7	5.48	74.0	117.7	4.96	12.2		10.0	2.23	5.2	1500	53.5	39.2	0.73	3.07	64.0	17.4	5.8								
				2200	94.9	5.42	76.4	109.9	5.13	10.6		1800	55.4	42.6	0.77	3.27	66.6	17.0	5.8											
	17.0	5.41	12.5	1800	95.5	5.54	76.6	119.1	5.05	12.6		13.5	3.47	8.0	1500	54.0	39.6	0.73	3.02	64.3	17.9	5.5								
				2200	97.9	5.48	79.2	111.2	5.24	11.2		1800	56.0	43.0	0.77	3.22	67.0	17.4	5.5											
90	8.5	1.60	3.7	1800	99.8	5.70	80.3	121.3	5.13	11.7	90	6.5	0.96	2.2	1500	49.1	37.6	0.77	3.53	61.1	13.9	8.2								
				2200	102.2	5.62	83.0	113.0	5.33	10.3					1800	51.3	40.8	0.80	3.76	64.1	13.6	8.2								
	13.0	2.80	6.5	1800	101.1	5.76	81.4	122.0	5.14	12.6		10.0	2.15	5.0	1500	49.7	37.9	0.76	3.46	61.4	14.4	7.8								
				2200	103.6	5.64	84.3	113.6	5.38	11.1		1800	51.7	41.2	0.80	3.68	64.3	14.1	7.8											
	17.0	5.22	12.1	1800	104.5	5.83	84.6	123.8	5.25	13.4		13.5	3.34	7.7	1500	50.7	38.2	0.75	3.50	62.6	14.5	7.3								
				2200	107.3	5.70	87.9	115.2	5.52	11.9		1800	52.3	41.6	0.80	3.62	64.7	14.4	7.4											
100	8.5	1.55	3.6	Operation not recommended							100	6.5	0.92	2.1	1500	44.7	36.4	0.81	4.02	58.4	11.1	10.3								
															1800	46.9	39.5	0.84	4.29	61.5	10.9	10.3								
	13.0	2.70	6.2									1500	45.2	36.7	0.81	3.94	58.6	11.5	9.7	10.0	2.07	4.8	1800	47.3	39.9	0.84	4.20	61.7	11.3	9.8
												1500	45.6	37.1	0.81	3.87	58.8	11.8	9.2	1800	47.8	40.3	0.84	4.13	61.9	11.6	9.2			
	17.0	5.03	11.6									1500	40.3	35.2	0.87	4.52	55.7	8.9	13.0	13.5	3.22	7.5	1800	42.4	38.2	0.90	4.82	58.9	8.8	13.1
												1500	40.7	35.5	0.87	4.42	55.8	9.2	12.3	1800	42.9	38.6	0.90	4.72	59.0	9.1	12.4			
110	8.5	1.50	3.5	Operation not recommended							110	6.5	0.89	2.1	1500	41.1	35.9	0.87	4.35	55.9	9.5	11.6								
															1800	43.3	39.0	0.90	4.64	59.1	9.3	11.7								
	13.0	2.60	6.0									1500	38.7	34.1	0.88	5.54	57.6	7.0	16.1	10.0	2.00	4.6	1800	39.6	37.1	0.94	5.67	58.9	7.0	16.2
												1500	39.2	34.4	0.88	5.24	57.1	7.5	15.2	1800	39.9	37.3	0.93	5.38	58.3	7.4	15.3			
	17.0	4.84	11.2									1500	39.6	34.4	0.87	5.07	56.9	7.8	14.3	13.5	2.98	6.9	1800	39.6	34.4	0.87	5.07	56.9	7.8	14.3
												1800	40.4	37.3	0.92	5.23	58.2	7.7	14.5											

Performance capacities shown in thousands of Btuh.

11/2/20

The manufacturer works continually to improve its products. As a result, the design and specifications of each product at the time of order may be changed without notice. Purchaser's approval of this data set signifies that the equipment is acceptable under the provisions of the job specification. Statements and other information contained herein are not express warranties and do not form the basis of any bargain between the parties, but are merely the manufacturer's opinion or commendation of its products.

Contractor: _____ P.O.: _____
 Engineer: _____
 Project Name: _____ Unit Tag: _____



Wiring Schematics

Aurora Variable Speed

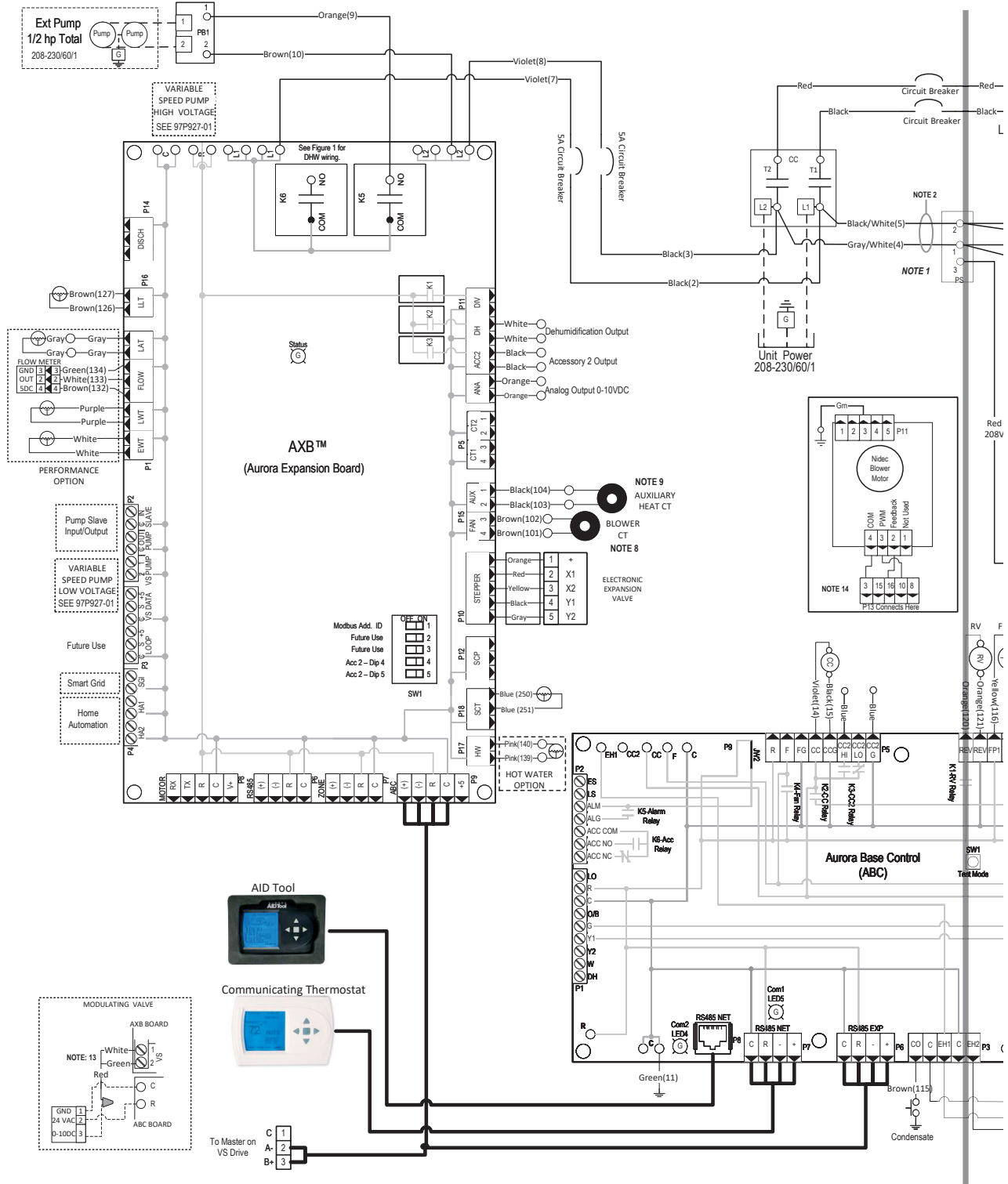

97P842-01A

The manufacturer continuously improves its products. As a result, the design and specifications of each product at the time of order may be changed without notice. Purchaser's approval of this data set signifies that the equipment is acceptable under the provisions of the job specification. Statements and other information contained herein are not express warranties and do not form the basis of any bargain between the parties, but are merely the manufacturer's opinion or commendation of its products.

Contractor: _____ P.O.: _____
 Engineer: _____
 Project Name: _____ Unit Tag: _____



Wiring Schematics cont.

Aurora Variable Speed cont.

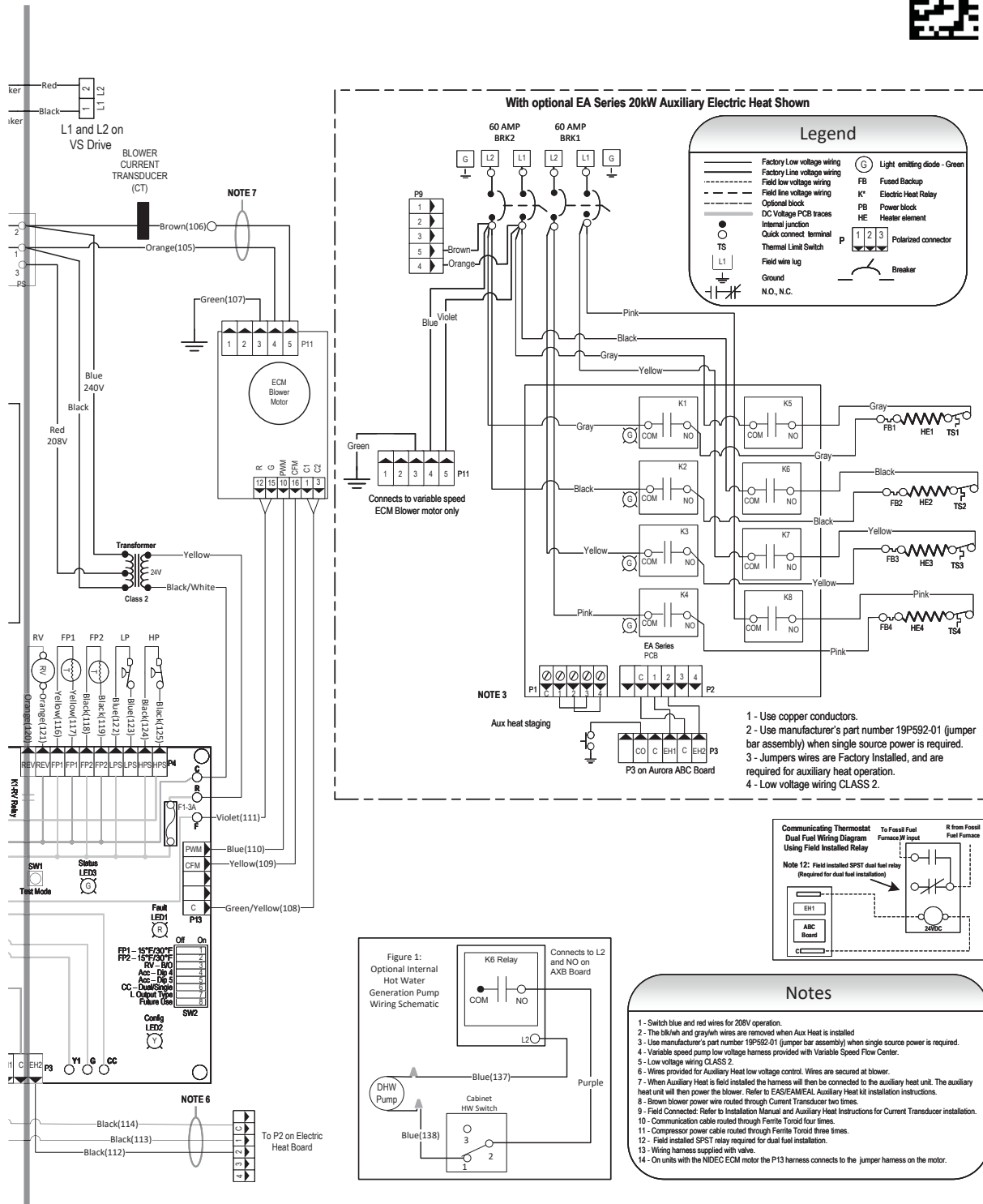

97P842-01A

The manufacturer works continually to improve its products. As a result, the design and specifications of each product at the time of order may be changed without notice. Purchaser's approval of this data set signifies that the equipment is acceptable under the provisions of the job specification. Statements and other information contained herein are not express warranties and do not form the basis of any bargain between the parties, but are merely the manufacturer's opinion or commendation of its products.

Contractor: _____ P.O.: _____

Engineer: _____

Project Name: _____ Unit Tag: _____



Wiring Schematics cont.

Aurora Variable Speed Drive

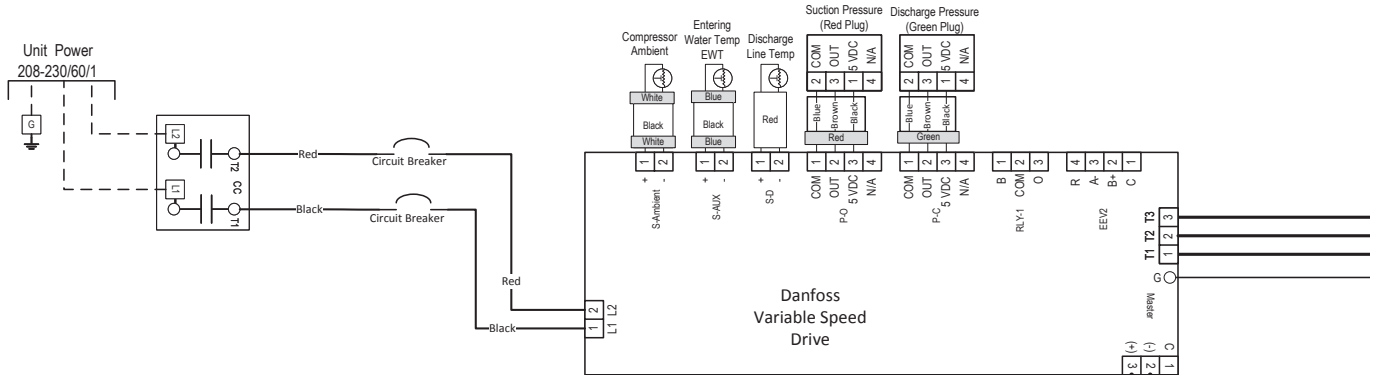

Legend

	Factory Low voltage wiring		Thermistor
	Factory Line voltage wiring		Light emitting diode - Green
	Field low voltage wiring		Relay coil
	Field line voltage wiring		Capacitor w/ bleed resistor
	Optional block		Switch - Condensate overflow
	DC Voltage PCB traces		Switch - High pressure
	Field Installed Item		Switch - Low pressure
	Junction		Current Transducer (CT)
	Quick connect terminal		Polarized connector
	Wire nut		
	Field wire lug		
	Ground		
	Fuse		
	Color identification tape on wire		

CC - Compressor Contactor
 CO - Condensate overflow sensor
 K5 - DHW pump relay
 K6 - Loop pump relay
 CR3 - PSC Fan Speed Relay
 CR4 - PSC Fan Power Relay
 CS - Compressor Solenoid
 F1, F2 - Fuses
 HE - Heater element
 HP - High pressure switch
 LP - Low pressure switch
 ER1 to ER4 - Aux heat stage relays

PB1, PB2 - Power blocks
 PS - Power strip
 RV - Reversing Valve coil
 SW1 - DIP Switch - 5 position AXB
 SW1 - TEST MODE ABC Board
 SW2 - DIP Switch - 8 position ABC Board
 FP1, FP2 - Freeze Protection
 TS - Thermal limit switch
 SC - Start Contactor
 SR - Start Relay
 HWL - Hot water limit sensor
 WCL - Water Coil Limit Sensor

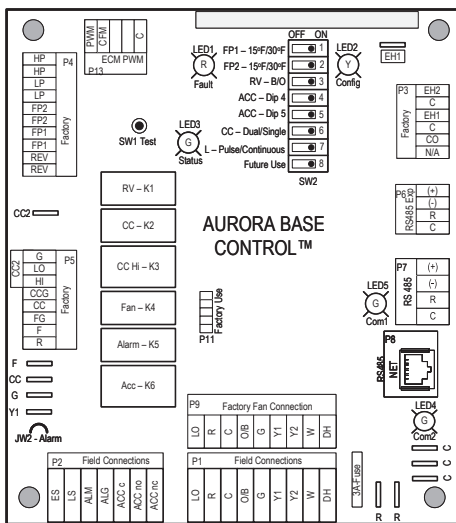
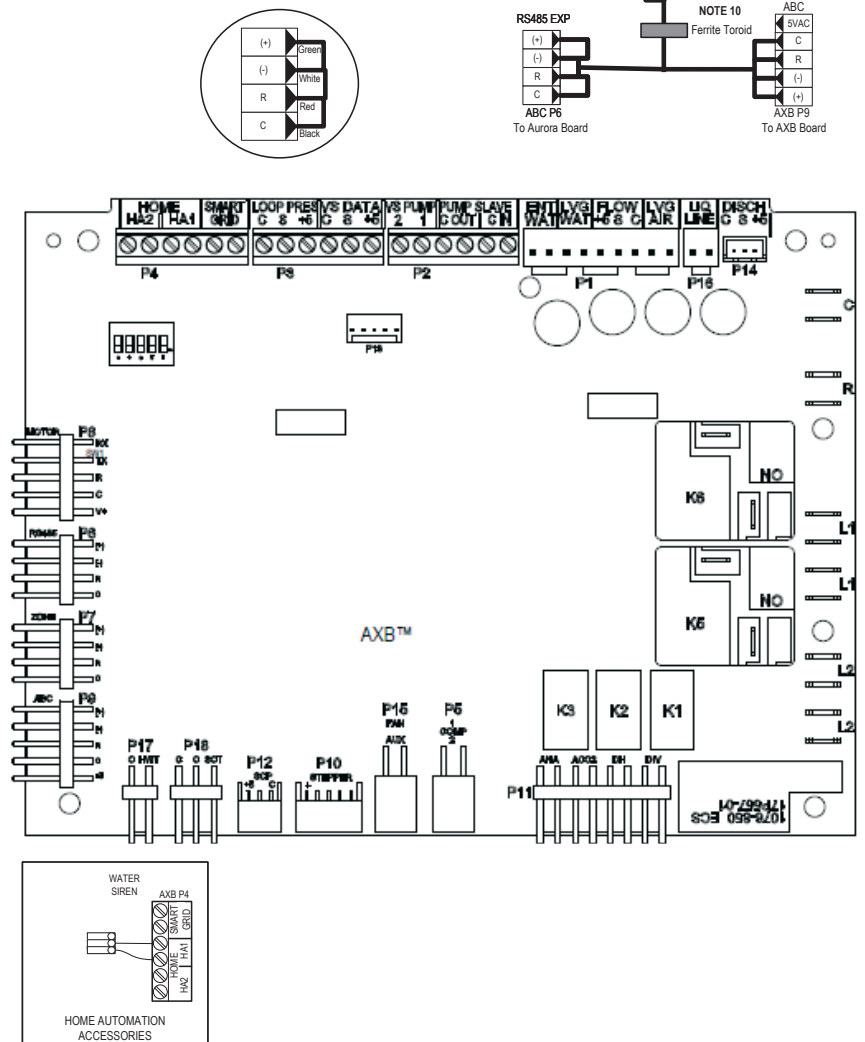

97P842-01B

The manufacturer works continually to improve its products. As a result, the design and specifications of each product at the time of order may be changed without notice. Purchaser's approval of this data set signifies that the equipment is acceptable under the provisions of the job specification. Statements and other information contained herein are not express warranties and do not form the basis of any bargain between the parties, but are merely the manufacturer's opinion or commendation of its products.

Contractor: _____ P.O.: _____

Engineer: _____

Project Name: _____ Unit Tag: _____

Sycamore Series
3 - 5 Tons 60Hz



Wiring Schematics cont.

Aurora Variable Speed Drive cont.

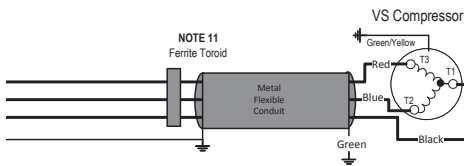

ABC SW2 Accessory Relay		
DESCRIPTION	SW2-4	SW2-5
Cycle with Blower	ON	ON
Cycle with Compressor	OFF	OFF
Water Valve Slow Opening	ON	OFF
Cycle with Comm. T-stat Hum Cmd	OFF	ON

AXB Accessory 2 DIP Settings		
SW1-4	SW1-5	DESCRIPTION
ON	ON	Cycles with Blower
OFF	ON	Cycles with CC first stage compressor or compressor spd 1-12
ON	OFF	Cycles with CC2 second stage of compressor or comp spd 7-12
OFF	OFF	Cycles with DH from ABC board

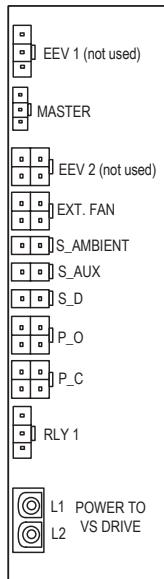

VARIABLE SPEED
DRIVE END VIEWS

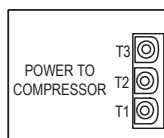

Aurora LED Flash Codes			
Slow Flash	1 second on and 1 second off		
Fast Flash	100 milliseconds on and 100 milliseconds off		
Flash Code	100 milliseconds on and 400 milliseconds off with a 2 second pause before repeating		
Fault LED (LED 1, Red)		Random Start Delay (Alternating Colors)	
Normal Mode	OFF	Status LED (LED1, Green)	Fast Flash
Input Fault Lockout	Flash Code 1	Configuration LED (LED 2, Yellow)	Fast Flash
High Pressure Lockout	Flash Code 2	Fault LED (LED 3, Red)	Fast Flash
Low Pressure Lockout	Flash Code 3	Configuration LED (LED 2, Yellow)	
Freeze Protection - FP2	Flash Code 4	No Software Override	OFF
Freeze Protection - FP1	Flash Code 5	DIP Switch Override	Slow Flash
Loss of Charge	Flash Code 6	Status LED (LED 3, Green)	
Condensate Overflow Lockout	Flash Code 7	Normal Mode	ON
Over/Under Voltage Shutdown	Flash Code 8	Control is Non - Functional	OFF
Future Use	Flash Code 9	Test Mode	Slow Flash
Fault - FP1 and FP2 Sensor Error	Flash Code 11	Dehumidification Mode	Flash Code 2
Future Use	Flash Code 12	Future Use	Flash Code 3
Non-Critical AXB Sensor Error	Flash Code 13	Future Use	Flash Code 4
Critical AXB Sensor Error	Flash Code 14	Load Shed	Flash Code 5
Alarm - Hot Water	Flash Code 15	ESD	Flash Code 6
Fault Variable Speed Pump	Flash Code 16	Future Use	Flash Code 7
Future Use	Flash Code 17	Fault LED (LED 1, Red) Cont.	
Non-Critical Communication Error	Flash Code 18	Safe Mode - Ambient Temperature Sensor	Flash Code 49
Fault - Critical Communication Error	Flash Code 19	Fault - Discharge Temperature Sensor	Flash Code 51
Alarm - Low Loop Pressure	Flash Code 21	Fault - Suction Pressure Sensor	Flash Code 52
Fault - Communication ECM Fan Motor Error	Flash Code 22	Fault - Condensing Pressure Sensor	Flash Code 53
Alarm - Home Automation 1	Flash Code 23	Fault - Low Supply Voltage	Flash Code 54
Alarm - Home Automation 2	Flash Code 24	Fault - Compressor Out of Envelope	Flash Code 55
Fault - EEV Error	Flash Code 25	Fault - Over Current	Flash Code 56
Derate - Drive Temperature	Flash Code 41	Fault - Over/Under Voltage	Flash Code 57
Derate - High Discharge Temperature	Flash Code 42	Fault - High Drive Temperature	Flash Code 58
Derate - Low Suction Temperature	Flash Code 43	Fault - Drive Internal Error MOC/AOC	Flash Code 59
Derate - Low Condensing Pressure	Flash Code 44	Fault - Multiple Safe Modes	Flash Code 61
Derate - High Condensing Pressure	Flash Code 45	Fault - Loss of Charge	Flash Code 71
Derate - Outer Power Limit	Flash Code 46	Safe Mode - Suction Temperature Sensor	Flash Code 72
Safe Mode - EEV (Indoor) Communication	Flash Code 47	Safe Mode - LAT Temperature Sensor	Flash Code 73
Safe Mode - EEV (Outdoor) Communication	Flash Code 48	Safe Mode - Max Operating Pressure	Flash Code 74

97P842-01B

The manufacturer works continually to improve its products. As a result, the design and specifications of each product at the time of order may be changed without notice. Purchaser's approval of this data set signifies that the equipment is acceptable under the provisions of the job specification. Statements and other information contained herein are not express warranties and do not form the basis of any bargain between the parties, but are merely the manufacturer's opinion or commendation of its products.

Contractor: _____ P.O.: _____

Engineer: _____

Project Name: _____ Unit Tag: _____



Engineering Guide Specifications

General

Furnish and install GeoStar Water Source Heat Pumps, as indicated on the plans. Equipment shall be completely assembled, piped and internally wired. Capacities and characteristics as listed in the schedule and the specifications that follow. The reverse cycle heating/ cooling units shall be either suspended type with horizontal air inlet and discharge or floor mounted type with horizontal air inlet and vertical upflow, downflow, or rear air discharge. Units shall be AHRI/ISO 13256-1 certified and listed by a nationally recognized safety-testing laboratory or agency, such as ETL Testing Laboratory. Each unit shall be computer run-tested at the factory with conditioned water and operation verified to catalog data. Each unit shall be mounted on a pallet and shipped in a corrugated box or stretch-wrapped. The units shall be designed to operate with entering liquid temperature between 20°F and 120°F [-6.7°C and 48.9°C].

Casing and Cabinet

The cabinet shall be fabricated from heavy-gauge galvanized steel and finished with corrosion-resistant powder coating. This corrosion protection system shall meet the stringent 1000 hour salt spray test per ASTM B117. The interior shall be insulated with 1/2-inch thick, multi-density, cleanable aluminum foil coated glass fiber with edges sealed or tucked under flanges to prevent the introduction of glass fibers into the discharge air. Standard cabinet panel insulation must meet NFPA 90A requirements, air erosion and mold growth limits of UL- 181, stringent fungal resistance test per ASTM-C1071 and ASTM G21, and shall meet zero level bacteria growth per ASTM G22. Unit insulation must meet these stringent requirements or unit(s) will not be accepted.

One (horizontal) to two (vertical) blower and three compressor compartment access panels shall be 'lift-out' removable with supply and return ductwork in place. The front access panel shall be lift-out to provide easy access to the electrical/compressor section. The control box shall be hinged and removable to allow easy access to the compressor. The internal component layout shall provide for service access from the front side for restricted installations.

A duct collar shall be provided on the supply air opening. Standard size 2 in. [5.1 cm] MERV 11 pleated filters shall be provided with each unit. Vertical and horizontal units shall have a return air filter rack/duct collar which is field convertible from 2 in. [5.1 cm] to 1 in. [2.5 cm]. The upflow vertical units shall have a removable insulated divider panel between the air handling section and the compressor section to minimize the transmission of compressor noise and to permit operational service testing without air bypass. Vertical units shall be supplied with left or right horizontal air inlet and top, bottom, or rear vertical air discharge. Horizontal units shall be supplied with left or right air inlet and side or end air discharge.

The compressor shall be double isolation mounted using selected durometer grommets to provide vibration free compressor mounting.

The drain pan shall be of plastic construction to inhibit corrosion and bacterial growth. Drain outlet shall be located on pan as to allow complete and unobstructed drainage of condensate. The unit as standard will be supplied with solid-state electronic condensate overflow protection. Mechanical float switches WILL NOT be accepted. Vertical units shall be furnished with a PVC slip condensate drain connection and an internal factory installed condensate trap.

Refrigerant Circuit

All units shall contain a sealed refrigerant circuit including a hermetic motor-compressor, discharge line muffler, bidirectional electronic expansion valve, finned tube air-to-refrigerant heat exchanger, reversing valve, coaxial tube water-to-refrigerant heat exchanger, optional hot water generator coil, and service ports. Compressors shall be high-efficiency variable speed scroll type designed for heat pump duty and mounted on double vibration isolators.

Compressor motors shall be permanent magnet type. The all-aluminum air coil shall be sized for low-face velocity and constructed of aluminum fins bonded to aluminum tubes in a staggered pattern not less than three rows deep for enhanced performance. All models shall include discharge mufflers to help quiet compressor discharge gas pulsations.

Refrigerant to air heat exchangers shall utilize tube construction rated to withstand 600 psig (4135 kPa) refrigerant working pressure. Refrigerant to water heat exchangers shall be of copper (cupronickel optional) inner water tube and steel refrigerant outer tube design, rated to withstand 600 psig (4135 kPa) working refrigerant pressure and 450 psig (3101 kPa) working water pressure. An electronic expansion valve shall provide proper superheat over the entire liquid temperature range with minimal "hunting." The valve shall operate bidirectionally without the use of check valves.

All units shall have the source coaxial tube refrigerant-to water heat exchanger and the optional hot water generator coil coated with ThermaShield insulation. Refrigerant suction lines shall be insulated to prevent condensation at low liquid temperatures.

Blower Motor and Assembly

The blower shall be a direct drive centrifugal type with a dynamically balanced wheel. The housing and wheel shall be designed for quiet low outlet velocity operation. The blower housing shall be removable from the unit without disconnecting the supply air ductwork for servicing of the blower motor. The blower motor shall be a variable-speed ECM type. The ECM blower motor shall be soft starting, shall maintain constant cfm over its operating static range, and shall provide 12 cfm settings. The blower motor shall be isolated from the housing by rubber grommets. The motor shall be permanently lubricated, have thermostatic overload protection and be long-life ball bearing type.

Contractor: _____ P.O.: _____

Engineer: _____

Project Name: _____ Unit Tag: _____



Engineering Guide Specifications cont.

Electrical

A control box shall be located within the unit compressor compartment and shall contain a 75VA transformer, 24 Volt activated, 2 pole compressor contactor, circuit breakers for protecting loop pumps and compressor drive, removable terminal block for thermostat wiring, variable speed compressor drive and solid-state controller for complete unit operation. Electromechanical operation WILL NOT be accepted. Units shall be name-plated for use with time delay fuses or HACR circuit breakers. Unit controls shall be communicating type and provide heating or cooling as required by the remote thermostat/sensor. An Aurora Advanced VS Control, a microprocessor based controller, interfaces with a digital communicating thermostat to monitor and control unit operation shall be provided. The control shall provide operational sequencing, blower speed control, blower failure, high and low pressure switch monitoring, freeze detection, hot water limit thermistor sensing, condensate overflow sensing, auxiliary heat staging, lockout mode control, hot water and loop pump control, LED status and fault indicators, fault memory, field selectable options, compressor envelope management, energy consumption measurement, and accessory output. The fault signals shall be plain English text and displayed on the thermostat.

The Aurora Advanced VS Control shall also feature an On Peak input signal for utility controlled demand programs, intelligent hot water generation with user adjustable temperature limit, loop pump linking for multiple units driving a common flow center and up to two optional home automation inputs to drive dedicated alarms for sump pump, security system, and smoke/CO₂ or dirty air filter sensors. As standard, the energy and refrigerant monitoring kits will provide real time data including total power consumption, refrigerant superheat and subcooling. Optional performance monitoring kit to provide real time data including, entering and leaving water temperature, flow rate and heat of extraction/rejection capacity data. The capability for communicating to advanced zoning packages with up to six zones shall also be provided with complete fault and information display on the zoning MasterStat.

A detachable terminal block with screw terminals will be provided for field control wiring. All units shall have knockouts for entrance of low and line voltage wiring. The blower motor and control box shall be harness plug wired for easy removal.

An optional Aurora Interface Diagnostic (AID) Tool shall communicate with the Aurora control allowing quick and easy access to setup, monitoring, and troubleshooting of any Aurora control. The device shall include the features of ECM airflow setup, VS pump and modulating water valve setup, fault description and history, manual operation capability, sensor readings, timings, and other diagnostic tools.

Piping

Supply and return water connections shall be 1 in. [25.4 mm] FPT brass swivel fittings, which provide a union and eliminate the need for pipe wrenches and sealants when making field connections. The optional hot water generator shall have sweat type connections. All source water piping shall be insulated to prevent condensation at low liquid temperatures. On the vertical units, the condensate connection shall be a 3/4 in. [19.1 mm] PVC socket with internally-trapped hose that can be routed to front or side locations.

Hanger Kit

(field-installed horizontal units only)

The hanger kit shall consist of galvanized steel brackets, bolts, lock washers, and isolators and shall be designed to fasten to the unit bottom panel for suspension from 3/8- inch threaded rods. All unit size shall include six brackets hanging brackets.

Options and Accessories

Cupronickel Heat Exchanger

An optional cupronickel water-to-refrigerant heat exchanger shall be provided.

Hot Water Generator

An optional ThermaShield coated heat reclaiming hot water generator coil of vented double-wall copper construction suitable for potable water shall be provided. The coil and hot water circulating pump shall be factory mounted inside the unit with integral electronic high limit temperature monitoring and external on/off switch. Hot water set point is selectable through the AID Tool.

Thermostat (field-installed)

A communicating auto-changeover electronic digital thermostat shall be provided. The thermostat shall offer variable speed heating and cooling staging with precise temperature control. An OFF-HEAT-AUTO-COOL-EMERG system switch, OFF-AUTO-INTERMITTENT blower switch, and indicating display shall be provided. The thermostat shall display in °F or °C. The thermostat shall provide real time energy consumption data of the unit.

Color Touchscreen Thermostat (field-installed)

A color touchscreen communicating auto-changeover electronic digital thermostat shall be provided. The thermostat shall offer variable speed heating and cooling staging with precise temperature control. An OFF-HEAT-AUTO-COOL-EMERG system switch, OFF-AUTO-INTERMITTENT blower switch, and indicating display shall be provided. The thermostat shall display in °F or °C. The thermostat shall provide real time and historical energy consumption data of the unit.

Contractor: _____ P.O.: _____

Engineer: _____

Project Name: _____ Unit Tag: _____



Engineering Guide Specifications cont.

Electronic Air Cleaner (field-installed)

A 1 in. [25 mm] electronic air cleaner, cleanable 97% efficiency at 0.3 microns and larger, shall be provided in lieu of the standard throwaway filter. The initial pressure drop across the filter shall not exceed 0.2 in. w.g. at 300 fpm force velocity.

Electrostatic Air Cleaner (field-installed)

A 1 in. [25 mm] electrostatic air cleaner, cleanable 90% efficiency, shall be provided in lieu of the standard throwaway filter. The initial pressure drop across the filter shall not exceed 0.15 in. w.g. at 300 fpm force velocity.

AlpinePure MERV 13 Filter

A 2 in. [50 mm] thick MERV 13 filter shall be provided in lieu of the standard filter and fits the factory filter rack. The filter maintains MERV 13 rating in full ASHRAE 52.2 independent testing as required for LEED® certification. Helps fulfill a full credit under the LEED rating system.

AlpinePure Drain Pan Treatment

Provides dependable, sustained time-release protection from slime build-up and foul smelling odors in the drain pan. Also adds a light, pleasant scent to the air.

Earth Loop Flow Center (field-installed)

A self-contained module shall provide all liquid flow, fill and connection requirements for ground source closed loop systems up to 20 gpm. The pumps shall be wired to a power block located in the nearest unit. The heat pump units shall contain low voltage pump linking control so that two units may share one flow center.

Auxiliary Heater (field-installed)

An electric resistance heater shall provide supplemental and/or emergency heating capability. Vertical units shall have the control panel and resistance heater coil assembly mounted internally. For horizontal units, the control panel shall be mounted internally while the resistance heater coil assembly shall be mounted externally. A low voltage plug shall be provided in each unit for quick auxiliary heat connection. The heater shall operate in sequenced stages as controlled by the unit's microprocessor. The heater shall feed line voltage power to the unit blower and transformer to provide emergency heat capability in the event of an open compressor circuit breaker.

Contractor: _____ P.O.: _____

Engineer: _____

Project Name: _____ Unit Tag: _____

Sycamore Series
3 - 5 Tons 60Hz



Revision Guide

Pages:	Description:	Date:	By:
Misc	Updated with Aluminum Air Coils	04 Dec 2020	MA
Misc	Updated Schematics, General Installation Information, Unit Startup (UPMXL)	20 Sept 2020	JM
All	Misc. Updates	04 Jan 2017	MA
Misc.	Misc. Updates, Updated Performance Data	12 Aug 2016	MA
All	Various Updates for Electric Heating Change	22 April 2015	MA
All	First Published.	01 Jul 2013	DS

The manufacturer works continually to improve its products. As a result, the design and specifications of each product at the time of order may be changed without notice. Purchaser's approval of this data set signifies that the equipment is acceptable under the provisions of the job specification. Statements and other information contained herein are not express warranties and do not form the basis of any bargain between the parties, but are merely the manufacturer's opinion or commendation of its products.

