

OPERATION & MAINTENANCE

Aston® Series Compact

R-454B

60Hz

GEOSTAR®

OMV5-0006GB



All Aston Series Compact models are safety listed and conforms to UL STDS 60335-1 & 60335-2-40 / Certified to CSA STDSC22.2 60335-1 & 60335-2-40 through ETL. Performance listed with AHRI in accordance with ASHRAE/ANSI/AHRI/ISO Standard 13256-1.



WARNING



WARNING: Before performing service or maintenance operations on the system, turn off main power switches to the unit. Electrical shock could cause serious personal injury.

WARNING: All products are designed, tested, and manufactured to comply with the latest publicly released and available edition of UL 60335-2-40 for electrical safety certification. All field electrical connections must follow the National Electrical Code (NEC) guide standards and / or any local codes that may be applicable for the installation.

WARNING: Only factory authorized personnel are approved for startup, check test and commissioning of this unit.

INSTALLER: Please take the time to read and understand these instructions prior to any installation. Installer must give a copy of this manual to the owner.

Definition of Warnings and Symbols

 DANGER	Indicates a situation that results in death or serious injury.
 WARNING	Indicates a situation that could result in death or serious injury.
 CAUTION	Indicates a situation that could result in minor or moderate injury.
NOTICE	Indicates a situation that could result in equipment or property damage.

For the User



WARNING

This appliance is not intended for use by persons (including children) with reduced physical, sensory, or mental capabilities, or lack of experience and knowledge, unless they have been given supervision or instruction concerning use of the appliance by a person responsible for their safety.

Children should be supervised to ensure that they do not play with the appliance.

Keep this manual in a safe place in order to provide your service personnel with necessary information.

NOTICE

NOTICE: To avoid equipment damage, do not leave the system filled in a building without heat during cold weather, unless adequate freeze protection levels of antifreeze are used. Heat exchangers do not fully drain and will freeze unless protected, causing permanent damage.

Table of Contents

UNIT OVERVIEW

Nomenclatures	6
AHRI Data	7
Physical Data	9
Dimensional Data	11
Hanger Bracket Locations	16
Electrical Availability	17
Electrical Data	18

OPERATING PRINCIPLES

Blower Performance Data	22
Antifreeze Corrections	26
Correction Factor Tables	27
Water Quality	28
Operating Limits and Parameters	29
Pressure Drop	31
Aurora® Controls Operation	32

SERVICE AND TROUBLESHOOTING

System Cleaning and Flushing	48
Refrigerant Circuit Guideline	49
Open Loop Ground Water System	50
Freeze Detection	50
Hot Gas Reheat/Hot Gas Bypass	51
Compressor and Thermistor Resistance	54
Troubleshooting Checklist	55
Control Board Troubleshooting Steps	56
Control Board Troubleshooting Flow Charts	58
Communicating Thermostat Troubleshooting Guide	70
Control Board Signals	72
Jumping the Control Board	75
Reference Calculations and Legend	78
Heat of Extraction / Rejection	79
Preventative Maintenance	81
Replacement Procedures	81
Troubleshooting	82
Decommissioning	84
Decommissioning - Unit Labeling Requirements	84
Refrigerant Recovery	85
Refrigerant Removal and Evacuation	85
Charging Procedures	86

REVISION GUIDE	87
----------------	----

General Installation Information

NOTICE: Do not store or install units in corrosive environments or in locations subject to temperature or humidity extremes. Corrosive conditions and high temperature or humidity can significantly reduce performance, reliability, and service life.

NOTICE: A minimum of 24 in. clearance should be allowed for access to front access panel.

NOTICE: To avoid equipment damage, DO NOT use these units as a source of heating or cooling during the construction process. The mechanical components and filters can quickly become clogged with construction dirt and debris, which may cause system damage and void product warranty.

For the Installer

If you are NOT sure how to install or operate the unit, contact your dealer.

Installing and servicing air conditioning and heating equipment can be hazardous due to system pressure and electrical components. Only trained and qualified service personnel should install, repair or service heating and air conditioning equipment. When working on heating and air conditioning equipment, observe precautions in the literature, tags and labels attached to the unit and other safety precautions that may apply.

This manual contains specific information about the required qualification of the working personnel for maintenance, service and repair operations. Every working procedure that affects safety means shall only be carried out by competent persons.

Examples for such working procedures are:

- breaking into the refrigerating circuit;
- opening of sealed components or ventilated enclosures.

Follow all safety codes. Wear safety glasses and work gloves. Use quenching cloth for brazing operations. Have fire extinguisher available for all brazing operations. Follow all procedures to remain in compliance with national gas regulations.

Prior to beginning work on systems containing FLAMMABLE REFRIGERANTS, safety checks are necessary to ensure that the risk of ignition is minimized. Work shall be undertaken under a controlled procedure so as to minimise the risk of a flammable gas or vapor being present while the work is being performed. All maintenance staff and others working in the local area shall be instructed on the nature of work being carried out. Work in confined spaces shall be avoided.

The area shall be checked with an appropriate refrigerant detector prior to and during work, to ensure the technician is aware of potentially toxic or flammable atmospheres. Ensure that the leak detection equipment being used is suitable for use with all applicable refrigerants, i.e. non-sparking, adequately sealed or intrinsically safe.

If any hot work is to be conducted on the refrigerating equipment or any associated parts, appropriate fire extinguishing equipment shall be available to hand. Have a dry powder or CO2 fire extinguisher adjacent to the charging area.

No person carrying out work in relation to a REFRIGERATING SYSTEM which involves exposing any pipe work shall use any sources of ignition in such a manner that it may lead to the risk of

fire or explosion. All possible ignition sources, including cigarette smoking, should be kept sufficiently far away from the site of installation, repairing, removing and disposal, during which refrigerant can possibly be released to the surrounding space. Prior to work taking place, the area around the equipment is to be surveyed to make sure that there are no flammable hazards or ignition risks. "No Smoking" signs shall be displayed.

Where electrical components are being changed, they shall be fit for the purpose and to the correct specification. At all times the manufacturer's maintenance and service guidelines shall be followed. If in doubt, consult the manufacturer's technical department for assistance.

The following checks shall be applied to installations using FLAMMABLE REFRIGERANTS:

- the actual REFRIGERANT CHARGE is in accordance with the room size within which the refrigerant containing parts are installed;
- the ventilation machinery and outlets are operating adequately and are not obstructed;
- if an indirect refrigerating circuit is being used, the secondary circuit shall be checked for the presence of refrigerant;
- marking to the equipment continues to be visible and legible. Markings and signs that are illegible shall be corrected;
- refrigerating pipe or components are installed in a position where they are unlikely to be exposed to any substance which may corrode refrigerant containing components, unless the components are constructed of materials which are inherently resistant to being corroded or are suitably protected against being so corroded.

WARNING

If the appliance locks out on E5: FREEZE PROTECTION FP1. The appliance must set for 5 hours before being restarted.

Instructions for Equipment Using R-454B Refrigerant

WARNING

- **Do NOT pierce or burn**
- **Do NOT use means to accelerate the defrosting process or to clean the equipment, other than those recommended by the manufacturer**
- **Be aware that refrigerants may not contain an odor**

WARNING

- **The Appliance should be stored so as to prevent mechanical damage and in a room without continuously operating ignition sources (example: open flames, an operating gas appliance or an operating electric heater)**

General Installation Information

WARNING

Ventilated Area: ensure that the area is in the open or that it is adequately ventilated before breaking into the system of conducting any hot work. A degree of ventilation should continue during the period that the work is carried out. The ventilation should safely disperse any released refrigerant and preferably expel it. Keep ventilation area clear of obstructions!

WARNING

Do NOT use potential sources of ignition in searching for or detection of refrigerant leaks. A halide torch (or any other detector using a naked flame) shall not be used.

The following leak detection methods are deemed acceptable for all refrigerant systems. Electronic leak detectors may be used to detect refrigerant leaks but, in the case of FLAMMABLE REFRIGERANTS, the sensitivity may not be adequate, or may need re-calibration. (Detection equipment shall be calibrated in a refrigerant-free area.) Ensure that the detector is not a potential source of ignition and is suitable for the refrigerant used. Leak detection equipment shall be set at a percentage of the LFL of the refrigerant and shall be calibrated to the refrigerant employed, and the appropriate percentage of gas (25 % maximum) is confirmed. Leak detection fluids are also suitable for use with most refrigerants but the use of detergents containing chlorine shall be avoided as the chlorine may react with the refrigerant and corrode the copper pipe-work. NOTE Examples of leak detection fluids are bubble method, fluorescent method agents. If a leak is suspected, all naked flames shall be removed/extinguished. If a leakage of refrigerant is found which requires brazing, all of the refrigerant shall be recovered from the system, or isolated (by means of shut off valves) in a part of the system remote from the leak. Removal of refrigerant shall follow the procedure outlined in this manual.

Installation Site

This equipment has been evaluated to be installed up to a maximum altitude of 3000m (9843ft) and should not be installed at an altitude greater than 3000m. For installation only in locations not accessible to the general public.

WARNING

For appliances using A2L refrigerants connected via an air duct system to one or more rooms, only auxiliary devices approved by the appliance manufacturer or declared suitable with the refrigerant shall be installed in connecting ductwork. The manufacturer shall list in the instructions all approved auxiliary devices by manufacturer and model number for use with the specific appliance, if those devices have a potential to become an ignition source.

Installation Space Requirements

NOTE: Equipment with refrigerant charge less than 63 oz does not have a minimum floor area requirement and does not require a refrigerant leak detection sensor. The sensor might be added as a feature.

WARNING

Equipment containing R-454B refrigerant shall be installed, operated, and stored in a room with floor area larger than the area defined in the “Minimum Floor Area” chart based on the total refrigerant charge in the system. This requirement applies to indoor equipment with or without a factory refrigerant leakage sensor.

CAUTION

It is not recommended to use a potable water source for this equipment water supply.

WARNING

This equipment comes with a factory installed Refrigerant Detection Device which is capable of determining it's specified end-of-life and replacement instructions. Refrigerant sensors for refrigerant detection systems shall only be replaced with sensors specified by the appliance manufacture.

WARNING

Take sufficient precautions in case of refrigerant leakage. If refrigerant gas leaks, ventilate the area immediately.
POSSIBLE RISKS: Excessive refrigerant concentrations in a closed room can lead to oxygen deficiency

WARNING

ALWAYS recover the refrigerant. Do NOT release them directly into the environment. Follow handling instructions carefully in compliance with national regulations.

WARNING

Check that cabling will not be subject to wear, corrosion, excessive pressure, vibration, sharp edges or any other adverse environmental effects. The check shall also take into account the effects of aging or continual vibration from sources such as compressors or fans.

Nomenclature

G5AV042BS0*N1CTLAANN010SSS

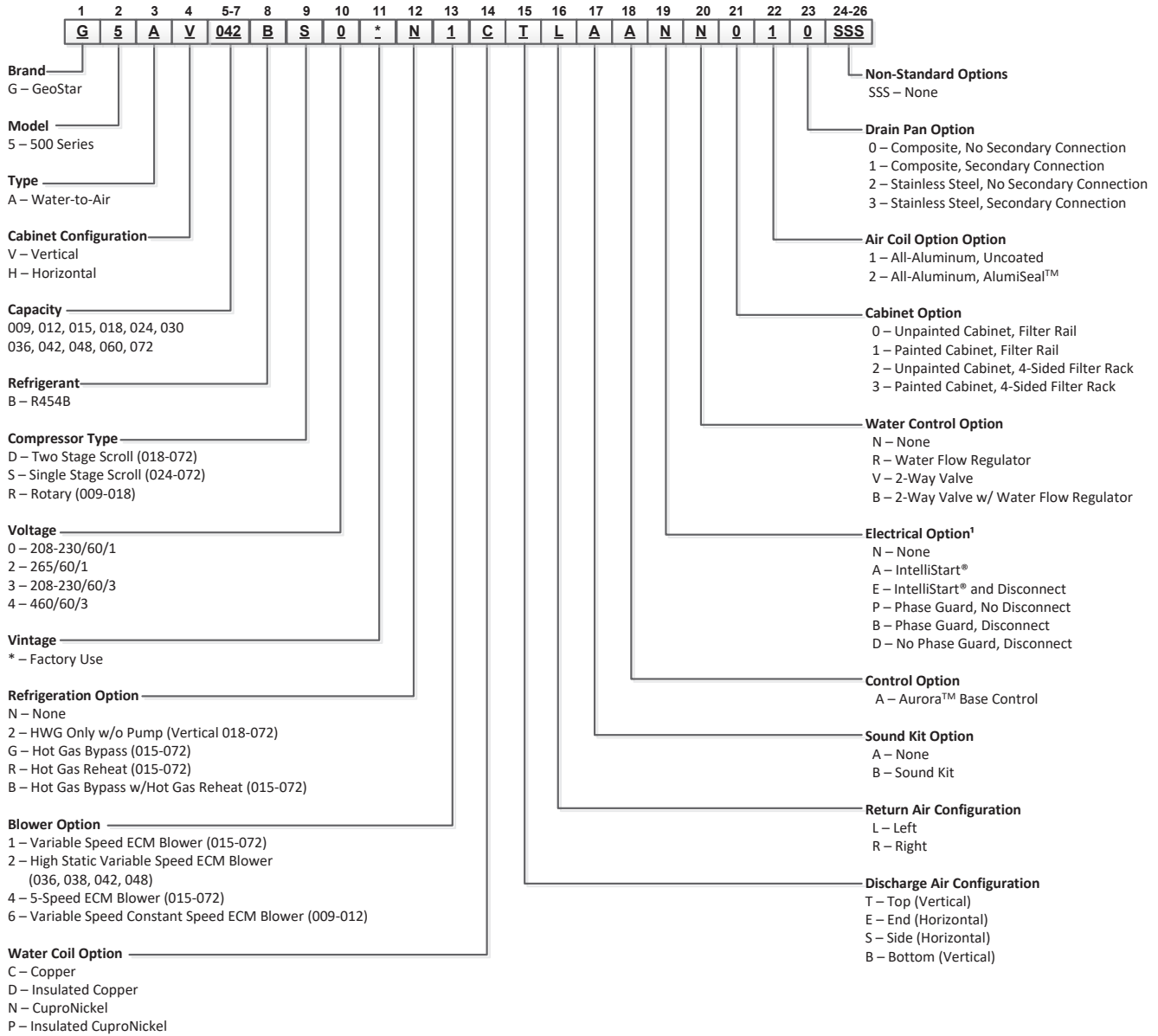

Note:
1 – Phase Guard Only Available on 208-230/60/3 and 460/60/3.

AHRI Data

AHRI/ASHRAE/ISO 13256-1 English (IP) Units

Model	Capacity Modulation	Flow Rate		Water Loop Heat Pump				Ground Water Heat Pump				Ground Loop Heat Pump			
				Cooling EWT 86°F		Heating EWT 68°F		Cooling EWT 59°F		Heating EWT 50°F		Cooling Brine Full Load 77°F Part Load 68°F		Heating Brine Full Load 32°F Part Load 41°F	
		gpm	cfm	Capacity Btuh	EER Btuh/W	Capacity Btuh	COP	Capacity Btuh	EER Btuh/W	Capacity Btuh	COP	Capacity Btuh	EER Btuh/W	Capacity Btuh	COP
009	Single	3.0	350	10,000	15.5	12,000	4.6	12,000	23.1	10,000	4.1	11,000	16.5	8,500	3.4
012	Single	3.5	400	12,000	16.0	15,000	5.2	14,000	26.0	12,400	4.3	13,000	18.0	9,500	3.6
015	Single	4.0	500	15,000	16.8	19,000	5.5	17,000	28.0	16,000	4.9	15,500	19.5	12,000	4.1
018	Single	5.0	600	18,000	15.5	23,000	5.3	20,600	25.0	18,500	4.6	18,500	18.3	14,500	4.0
024	Single	8.0	800	24,500	17.5	30,000	5.4	28,000	28.0	24,000	4.7	26,000	20.6	19,000	4.0
030	Single	8.0	900	30,000	17.5	36,000	5.3	33,000	28.0	30,000	4.5	30,000	21.0	23,000	3.9
036	Single	9.0	1200	36,000	18.8	39,000	5.8	39,000	29.0	32,000	5.0	37,500	21.5	26,000	4.2
042	Single	11.0	1300	42,000	18.4	49,000	6.0	45,000	27.0	39,000	5.2	42,000	21.2	32,000	4.2
048	Single	12.0	1500	49,000	16.8	58,500	5.6	53,500	26.0	48,000	4.8	51,000	19.0	38,500	4.2
060	Single	15.0	1800	61,500	16.8	71,000	5.3	68,000	25.0	59,200	4.7	63,000	19.2	47,900	3.9
072	Single	18.0	2000	67,000	15.3	86,000	5.1	76,000	23.0	68,000	4.4	70,000	17.8	54,000	3.7
018	Full	5.0	600	17,600	16.8	22,500	5.7	20,800	27.0	18,900	5.0	18,700	19.8	14,700	4.2
	Part	4.0	500	13,400	16.9	17,000	6.1	15,200	29.5	14,200	5.1	14,700	24.8	12,400	4.7
024	Full	8.0	950	23,800	16.1	28,000	5.7	26,400	25.2	23,300	4.9	25,000	19.2	19,400	4.1
	Part	7.0	750	17,700	18.3	20,300	6.4	19,700	31.8	16,900	5.2	19,600	26.6	15,800	4.6
030	Full	8.0	1000	30,800	17.3	38,600	5.6	35,200	27.5	31,100	4.8	32,300	20.3	24,600	4.0
	Part	7.0	800	22,400	19.0	27,200	6.1	26,100	35.9	21,800	4.9	24,800	28.7	19,400	4.3
036	Full	9.0	1300	36,400	17.9	43,300	6.1	41,800	28.4	36,000	5.3	38,500	20.8	29,600	4.5
	Part	8.0	1150	27,600	20.0	31,200	6.8	31,000	35.6	25,900	5.5	30,300	30.0	23,600	5.0
042	Full	11.0	1300	40,100	16.5	50,500	5.9	46,200	26.6	41,700	5.2	41,700	19.2	33,700	4.4
	Part	10.0	1200	29,300	17.5	36,500	6.8	34,400	32.7	29,700	5.5	33,100	26.9	26,600	4.9
048	Full	12.0	1600	46,600	16.1	59,600	5.7	53,100	24.9	49,300	5.1	50,500	18.9	40,100	4.4
	Part	11.0	1400	34,300	17.4	43,100	6.7	39,900	32.7	35,500	5.5	39,200	27.3	32,000	5.0
060	Full	16.0	1800	61,600	16.5	64,600	5.2	68,400	24.2	56,100	4.7	66,000	19.3	47,600	4.1
	Part	14.0	1500	42,900	17.4	45,800	5.9	49,400	31.4	38,700	4.9	49,100	26.5	35,500	4.4
072	Full	18.0	2000	70,100	16.0	87,800	5.1	78,100	23.1	71,400	4.6	73,400	18.3	57,900	4.0
	Part	16.0	1500	52,800	17.2	64,800	5.4	58,900	29.7	52,600	4.6	56,300	25.1	47,600	4.2

5/7/24

Cooling capacities based upon 80.6°F DB, 66.2°F WB entering air temperature
 Heating capacities based upon 68°F DB, 59°F WB entering air temperature
 All ratings based upon 208V operation



AHRI Data cont

The performance standard AHRI/ASHRAE/ISO 13256-1 became effective January 1, 2000 and replaces AHRI Standards 320, 325, and 330. This new standard has three major categories: Water Loop (comparable to ARI 320), Ground Water (ARI 325), and Ground Loop (ARI 330). Although these standards are similar there are some differences:

Unit of Measure: The Cooling COP

The cooling efficiency is measured in EER (US version measured in Btu/h per Watt. The Metric version is measured in a cooling COP (Watt per Watt) similar to the traditional COP measurement.

Water Conditions Differences

Entering water temperatures have changed to reflect the Celcius temperature scale. For instance the water loop heating test is performed with 68°F (20°C) water rounded down from the old 70°F (21.1°C).

Air Conditions Differences

Entering air temperatures have also changed (rounded down) to reflect the Celcius temperature scale. For instance the cooling tests are performed with 80.6°F (27°C) dry bulb and 66.2°F (19°C) wet bulb entering air instead of the traditional 80°F (26.7°C) DB and 67°F (19.4°C) WB entering air temperatures. 80.6/66.2 data may be converted to 80/67 using the entering air correction table. This represents a significantly lower relative humidity than the old 80/67 of 50% and will result in lower latent capacities.

Pump Power Correction Calculation

Within each model, only one water flow rate is specified for all three groups and pumping Watts are calculated using the following formula. This additional power is added onto the existing power consumption.

- Pump power correction = (gpm x 0.0631) x (Press Drop x 2990) / 300

Where 'gpm' is waterflow in gpm and 'Press Drop' is the pressure drop through the unit heat exchanger at rated water flow in feet of head.

Blower Power Correction Calculation

Blower power is corrected to zero external static pressure using the following equation. The nominal airflow is rated at a specific external static pressure. This effectively reduces the power consumption of the unit and increases cooling capacity but decreases heating capacity. These Watts are significant enough in most cases to increase EER and COPs fairly dramatically over ARI 320, 325, and 330 ratings.

- Blower Power Correction = (cfm x 0.472) x (esp x 249) / 300

Where 'cfm' is airflow in cfm and 'esp' is the external static pressure at rated airflow in inches of water gauge.

ISO Capacity and Efficiency Calculations

The following equations illustrate cooling calculations:

- ISO Cooling Capacity = Cooling Capacity (Btu/h) + (Blower Power Correction (Watts) x 3.412)

- ISO EER Efficiency (W/W) = ISO Cooling Capacity (Btu/h) x 3.412 / [Power Input (Watts) - Blower Power Correction (Watts) + Pump Power Correction (Watt)]

The following equations illustrate heating calculations:

- ISO Heating Capacity = Heating Capacity (Btu/h) - (Blower Power Correction (Watts) x 3.412)

- ISO COP Efficiency (W/W) = ISO Heating Capacity (Btu/h) x 3.412 / [Power Input (Watts) - Blower Power Correction (Watts) + Pump Power Correction (Watt)]

Comparison of Test Conditions

	ARI 320	ISO/AHRI 13256-1 WLHP	ARI 325	ISO/AHRI 13256-1 GWHP	ARI 330	ISO/AHRI 13256-1 GLHP
Cooling						
Entering Air - DB/WB °F	80/67	80.6/66.2	80/67	80.6/66.2	80/67	80.6/66.2
Entering Water - °F	85	86	50/70	59	77	77
Fluid Flow Rate	*	**	**	**	**	**
Heating						
Entering Air - DB/WB °F	70	68	70	68	70	68
Entering Water - °F	70	68	50/70	50	32	32
Fluid Flow Rate	*	**	**	**	**	**

Note *: Flow rate is set by 10°F rise in standard cooling test
Part load entering water conditions not shown.

Note **: Flow rate is specified by the manufacturer

WLHP = Water Loop Heat Pump; GWHP = Ground Water Heat Pump; GLHP = Ground Loop Heat Pump

Conversions:

Airflow (lps) = cfm x 0.472;

esp (Pascals) = esp (in wg) x 249;

Water Flow (lps) = gpm x 0.0631;

Press Drop (Pascals) = Press Drop (ft hd) x 2990

Physical Data - Dual Capacity

Model		Dual Capacity							
		018	024	030	036	042	048	060	072
Compressor (1 each)		Two Stage Scroll							
Factory Charge R-454B, oz [kg]	Vertical	32 [0.91]	50 [1.42]	56 [1.59]	54 [1.53]	56 [1.59]	62 [1.76]	76 [2.15]	104 [2.95]
Factory Charge R-454B, oz [kg]	Horizontal	36 [0.93]	48 [1.36]	54 [1.53]	54 [1.53]	62 [1.76]	72 [2.04]	84 [2.38]	104 [2.95]
Blower Motor & Blower									
Blower Motor Type/Speeds	VS ECM	Variable Speed ECM							
	5-Speed ECM	5- Speed ECM							
Blower Motor- hp [W]	VS ECM	1/2 [373]	1/2 [373]	1/2 [373]	1/2 [373]	1/2 [373]	1/2 [373]	1 [746]	1 [746]
	5-Speed ECM	1/2 [373]	1/2 [373]	1/2 [373]	1/2 [373]	1 [746]	1 [746]	1 [746]	1 [746]
High Static Blower Motor - hp [W]	VS ECM	not available	not available	not available	1 [746]	1 [746]	1 [746]	not available	not available
Blower Wheel Size (Dia x W), in. [mm]	VS ECM	9 x 7 [229 x 178]	9 x 7 [229 x 178]	9 x 7 [229 x 178]	11 x 10 [279 x 254]	11 x 10 [279 x 254]	11 x 10 [279 x 254]	11 x 10 [279 x 254]	11 x 10 [279 x 254]
	5-Speed ECM	9 x 7 [229 x 178]	9 x 7 [229 x 178]	9 x 7 [229 x 178]	11 x 10 [279 x 254]	11 x 10 [279 x 254]	11 x 10 [279 x 254]	11 x 10 [279 x 254]	11 x 10 [279 x 254]
High Static Wheel Size (Dia x W), in. [mm]	VS ECM	not available	not available	not available	11 x 10 [279 x 254]	11 x 10 [279 x 254]	11 x 10 [279 x 254]	not available	not available
Coax and Water Piping									
Water Connections Size - FPT - in [mm]		3/4" [19.05]	3/4" [19.05]	3/4" [19.05]	1" [25.4]	1" [25.4]	1" [25.4]	1" [25.4]	1" [25.4]
HWG Connection Size - Female Sweat I.D. - in [mm] (Vertical Only)		1/2" [12.7]	1/2" [12.7]	1/2" [12.7]	1/2" [12.7]	1/2" [12.7]	1/2" [12.7]	1/2" [12.7]	1/2" [12.7]
Coax & Piping Water Volume - gal [l]		0.40 [1.5]	0.7 [2.6]	1.0 [3.8]	1.3 [4.9]	1.3 [4.9]	1.6 [6.1]	1.6 [6.1]	2.3 [8.7]
Vertical									
Air Coil Dimensions (H x W), in. [mm]		19 x 20 [483 x 508]	24 x 20 [610 x 542]	28 x 20 [711 x 542]	28 x 25 [711 x 635]	32 x 25 [813 x 635]	32 x 25 [813 x 635]	36 x 25 [914 x 635]	36 x 25 [914 x 635]
Air Coil Total Face Area, ft2 [m2]		2.6 [0.242]	3.3 [0.310]	3.9 [0.362]	4.9 [0.451]	5.6 [0.570]	5.6 [0.570]	6.3 [0.641]	6.3 [0.641]
Air Coil Tube Size, in [mm]		3/8 [9.5]	3/8 [9.5]	3/8 [9.5]	3/8 [9.5]	5/16 [7.9]	5/16 [7.9]	3/8 [9.5]	3/8 [9.5]
Air Coil Number of rows		3	3	3	3	4	4	4	4
Filter Standard - 1" [25mm] Pleated MERV 4 Throwaway, in [mm]		1 - 24 x 24 [610 x 610]	28 x 24 [712 x 610]	28 x 24 [712 x 610]	28 x 30 [712 x 762]	32 x 30 [813 x 762]	32 x 30 [813 x 762]	30 x 36 [762 x 914]	30 x 36 [762 x 914]
Filter Standard - 2" [51mm] Pleated MERV 13 Throwaway, in [mm]		1 - 24 x 24 [610 x 610]	28 x 24 [712 x 610]	28 x 24 [712 x 610]	28 x 30 [712 x 762]	32 x 30 [813 x 762]	32 x 30 [813 x 762]	30 x 36 [762 x 914]	30 x 36 [762 x 914]
Horizontal									
Air Coil Dimensions (H x W), in. [mm]		18 x 21 [457 x 533]	18 x 27 [457 x 686]	18 x 30 [457 x 762]	20 x 35 [508 x 889]	20 x 40 [508 x 1016]	20 x 40 [508 x 1016]	20 x 45 [508 x 1143]	20 x 45 [508 x 1143]
Air Coil Total Face Area, ft2 [m2]		2.6 [0.242]	3.4 [0.316]	3.9 [0.362]	4.9 [0.451]	5.6 [0.570]	5.6 [0.570]	6.3 [0.641]	6.3 [0.641]
Air Coil Tube Size, in [mm]		5/16 [7.9]	3/8 [9.5]	3/8 [9.5]	3/8 [9.5]	3/8 [9.5]	3/8 [9.5]	3/8 [9.5]	3/8 [9.5]
Air Coil Number of rows		3	3	3	3	3	3	4	4
Filter Standard - 1" [25mm] Pleated MERV 4 Throwaway, in [mm]		1 - 18 x 14 [457 x 356] 1 - 18 x 16 [457 x 406]	1 - 18 x 18 [457 x 457] 1 - 18 x 14 [457 x 356]	1 - 18 x 18 [457 x 457] 1 - 18 x 14 [457 x 356]	1 - 18 x 20 [457 x 508] 1 - 20 x 20 [508 x 508]	1 - 20 x 20 [508 x 508] 1 - 20 x 22 [508 x 559]	1 - 20 x 20 [508 x 508] 1 - 20 x 22 [508 x 559]	1 - 20 x 25 [508 x 635] 1 - 20 x 22 [508 x 559]	1 - 20 x 25 [508 x 635] 1 - 20 x 22 [508 x 559]
Filter Standard - 2" [51mm] Pleated MERV 13 Throwaway, in [mm]		1 - 18 x 29 [457 x 737]	1 - 18 x 32 [457 x 813]	1 - 18 x 32 [457 x 813]	1 - 20 x 37 [686 x 940]	1 - 20 x 20 [508 x 508] 1 - 20 x 22 [508 x 559]	1 - 20 x 20 [508 x 508] 1 - 20 x 22 [508 x 559]	1 - 20 x 25 [508 x 635] 1 - 20 x 22 [508 x 559]	1 - 20 x 25 [508 x 635] 1 - 20 x 22 [508 x 559]

Physical Data - Single Speed

Model		Single Speed											
		009	012	015	018	024	030	036	042	048	060	072	
Compressor (1 each)		Fixed Speed Rotary					Single Stage Scroll						
Factory Charge R-454B, oz [kg]	Vertical	24 [0.68]	30 [0.85]	34 [0.96]	32 [0.91]	44 [1.25]	52 [1.47]	52 [1.47]	56 [1.59]	58 [1.64]	74 [2.10]	100 [2.83]	
Factory Charge R-454B, oz [kg]	Horizontal	28 [0.79]	26 [0.74]	30 [0.85]	36 [1.02]	44 [1.25]	54 [1.53]	58 [1.64]	62 [1.76]	68 [1.93]	74 [2.10]	104 [2.95]	
Blower Motor & Blower													
Blower Motor Type/Speeds	VS ECM	Variable Speed (Constant Speed)			Variable Speed (Constant CFM)								
	5-Speed ECM	Not Available			5 Speeds								
Blower Motor- hp [W]	VS ECM	1/10 [75]	1/10 [75]	1/2 [373]	1/2 [373]	1/2 [373]	1/2 [373]	1/2 [373]	1/2 [373]	1/2 [373]	1 [746]	1 [746]	
	5-Speed ECM	Not Available		1/2 [373]	1/2 [373]	1/2 [373]	1/2 [373]	1/2 [373]	1 [746]	1 [746]	1 [746]	1 [746]	
High Static Blower Motor - whp [W]	VS ECM	Not Available					1 [746]	1 [746]	1 [746]	Not Available			
Blower Wheel Size (Dia x W), in. [mm]	VS ECM	6 x 8 [152 x 203]	6 x 8 [152 x 203]	6 x 8 [152 x 203]	9 x 7 [229 x 178]	9 x 7 [229 x 178]	9 x 7 [229 x 178]	9 x 7 [229 x 178]	11 x 10 [279 x 254]	11 x 10 [279 x 254]	11 x 10 [279 x 254]	11 x 10 [279 x 254]	11 x 10 [279 x 254]
	5-Speed ECM	Not Available		9 x 7 [229 x 178]	9 x 7 [229 x 178]	9 x 7 [229 x 178]	9 x 7 [229 x 178]	11 x 10 [279 x 254]	11 x 10 [279 x 254]	11 x 10 [279 x 254]	11 x 10 [279 x 254]	11 x 10 [279 x 254]	
High Static Wheel Size (Dia x W), in. [mm]	VS ECM	Not Available					11 x 10 [279 x 254]	11 x 10 [279 x 254]	11 x 10 [279 x 254]	Not Available			
Coax and Water Piping													
Water Connections Size - FPT - in [mm]		1/2" [12.7]	1/2" [12.7]	3/4" [19.05]	3/4" [19.05]	3/4" [19.05]	3/4" [19.05]	1" [25.4]	1" [25.4]	1" [25.4]	1" [25.4]	1" [25.4]	
HWG Connection Size - Female Sweat I.D. - in [mm] (Vertical Only)		Not Available			1/2" [12.7]	1/2" [12.7]	1/2" [12.7]	1/2" [12.7]	1/2" [12.7]	1/2" [12.7]	1/2" [12.7]	1/2" [12.7]	
Coax & Piping Water Volume - gal [l]		0.26 [0.98]	0.3 [1.12]	0.4 [1.49]	0.4 [1.49]	0.4 [1.49]	0.75 [2.83]	0.9 [3.41]	0.9 [3.41]	1.25 [4.72]	1.5 [5.68]	1.5 [5.68]	
Vertical													
Air Coil Dimensions (H x W), in. [mm]		12 x 16 [305 x 406]	16 x 16 [406 x 406]	19 x 20 [483 x 508]	19 x 20 [483 x 508]	24 x 20 [610 x 508]	28 x 20 [711 x 508]	28 x 25 [711 x 635]	32 x 25 [813 x 635]	32 x 25 [813 x 635]	36 x 25 [914 x 635]	36 x 25 [914 x 635]	
Air Coil Total Face Area, ft2 [m2]		1.3 [0.121]	1.8 [0.167]	2.6 [0.242]	2.6 [0.242]	3.3 [0.307]	3.9 [0.362]	4.9 [0.455]	5.6 [0.570]	5.6 [0.570]	6.3 [0.585]	6.3 [0.585]	
Air Coil Tube Size, in [mm]		5/16 [7.9]	3/8 [9.5]	5/16 [7.9]	5/16 [7.9]	3/8 [9.5]	3/8 [9.5]	3/8 [9.5]	5/16 [7.9]	5/16 [7.9]	3/8 [9.5]	3/8 [9.5]	
Air Coil Number of rows		3	3	3	3	3	3	3	4	4	4	4	
Filter Standard - 1" [25mm] Pleated MERV 4 Throwaway, in [mm]		1 - 16 x 20 [406 x 508]	1 - 16 x 20 [406 x 508]	1 - 24 x 24 [610 x 610]	1 - 24 x 24 [610 x 610]	28 x 24 [712 x 610]	28 x 24 [712 x 610]	28 x 30 [712 x 762]	32 x 30 [813 x 762]	32 x 30 [813 x 762]	30 x 36 [762 x 914]	30 x 36 [762 x 914]	
Filter Standard - 2" [51mm] Pleated MERV 13 Throwaway, in [mm]		1 - 16 x 20 [406 x 508]	1 - 16 x 20 [406 x 508]	1 - 24 x 24 [610 x 610]	1 - 24 x 24 [610 x 610]	28 x 24 [712 x 610]	28 x 24 [712 x 610]	28 x 30 [712 x 762]	32 x 30 [813 x 762]	32 x 30 [813 x 762]	30 x 36 [762 x 914]	30 x 36 [762 x 914]	
Horizontal													
Air Coil Dimensions (H x W), in. [mm]		12 x 16 [305 x 406]	16 x 16 [406 x 406]	18 x 21 [457 x 533]	18 x 21 [457 x 533]	18 x 27 [457 x 686]	18 x 30 [457 x 762]	20 x 35 [508 x 889]	20 x 40 [508 x 1016]	20 x 40 [508 x 1016]	20 x 45 [508 x 1143]	20 x 45 [508 x 1143]	
Air Coil Total Face Area, ft2 [m2]		1.3 [0.121]	1.8 [0.167]	2.6 [0.242]	2.6 [0.242]	3.4 [0.316]	3.8 [0.353]	4.9 [0.455]	5.6 [0.520]	5.6 [0.520]	6.3 [0.585]	6.3 [0.585]	
Air Coil Tube Size, in [mm]		5/16 [7.9]	3/8 [9.5]	5/16 [7.9]	5/16 [7.9]	3/8 [9.5]	3/8 [9.5]	3/8 [9.5]	3/8 [9.5]	3/8 [9.5]	3/8 [9.5]	3/8 [9.5]	
Air Coil Number of rows		3	3	3	3	3	3	3	3	3	3	3	
Filter Standard - 1" [25mm] Pleated MERV 4 Throwaway, in [mm]		1 - 16 x 18 [406 x 508]	1 - 16 x 18 [406 x 508]	1 - 18 x 14 [457 x 356] 1 - 18 x 16 [457 x 406]	1 - 18 x 14 [457 x 356] 1 - 18 x 16 [457 x 406]	1 - 18 x 18 [457 x 457] 1 - 18 x 14 [457 x 356]	1 - 18 x 18 [457 x 457] 1 - 18 x 14 [457 x 356]	1 - 18 x 20 [457 x 508] 1 - 20 x 20 [508 x 508]	1 - 20 x 20 [508 x 508] 1 - 20 x 22 [508 x 559]	1 - 20 x 20 [508 x 508] 1 - 20 x 22 [508 x 559]	1 - 20 x 25 [508 x 635] 1 - 20 x 22 [508 x 559]	1 - 20 x 25 [508 x 635] 1 - 20 x 22 [508 x 559]	
Filter Standard - 2" [51mm] Pleated MERV 13 Throwaway, in [mm]		1 - 16 x 18 [406 x 508]	1 - 16 x 18 [406 x 508]	1 - 18 x 29 [457 x 737]	1 - 18 x 29 [457 x 737]	1 - 18 x 32 [457 x 813]	1 - 18 x 32 [457 x 813]	1 - 20 x 37 [686 x 940]	1 - 20 x 20 [508 x 508] 1 - 20 x 22 [508 x 559]	1 - 20 x 20 [508 x 508] 1 - 20 x 22 [508 x 559]	1 - 20 x 25 [508 x 635] 1 - 20 x 22 [508 x 559]	1 - 20 x 25 [508 x 635] 1 - 20 x 22 [508 x 559]	

Dimensional Data - Vertical

VERTICAL DIMENSIONAL DATA

Legend	
AP	= Alternate Service Panel
BP	= Blower Service Panel
CP	= Control Access Panel
CMP	= Compressor Service Panel

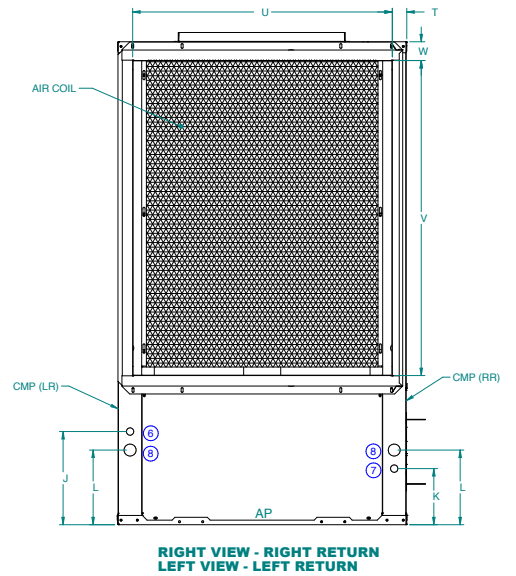
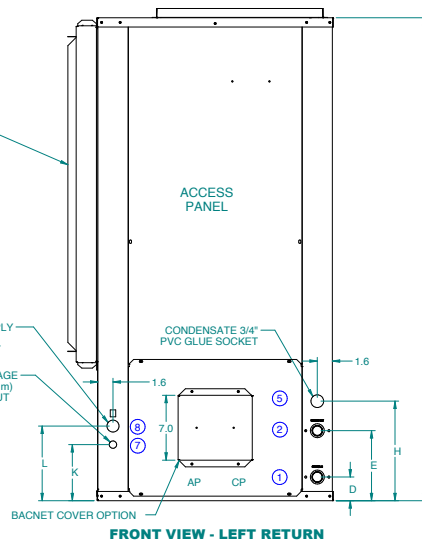
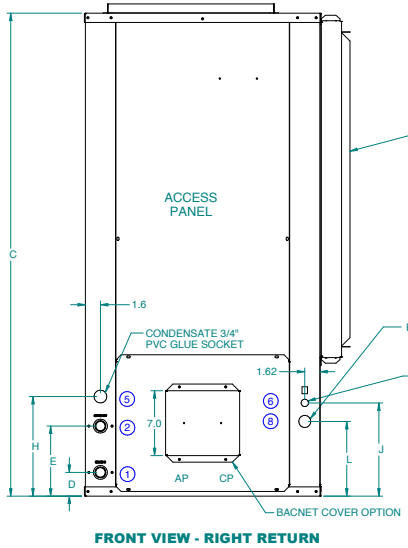
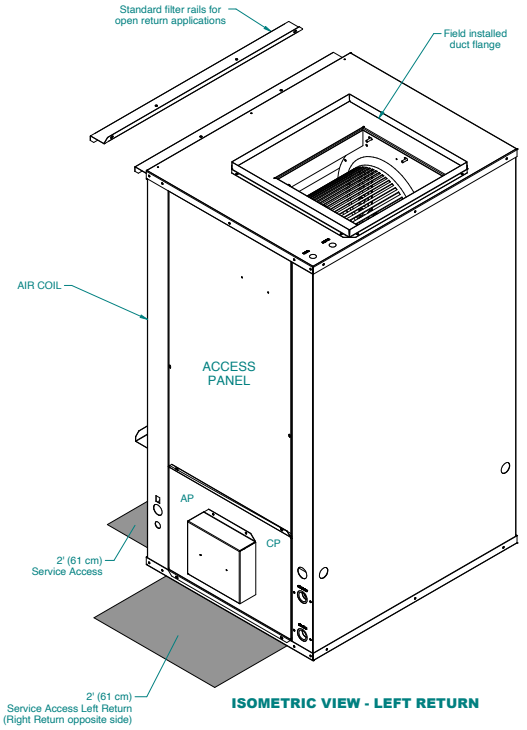
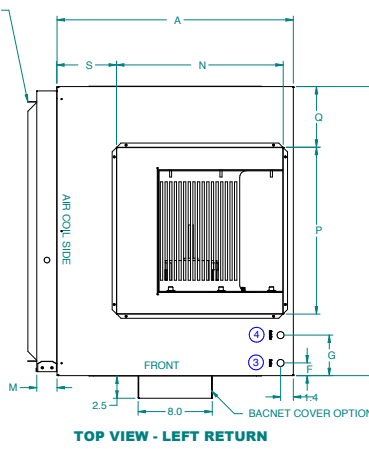
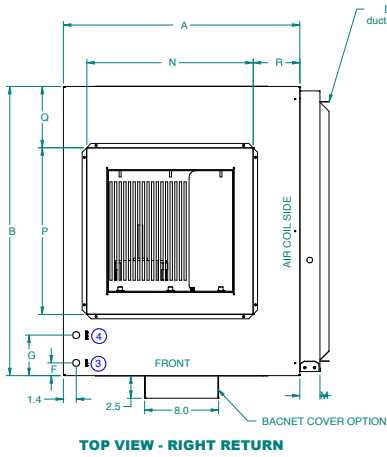

Dimensional Data - Vertical cont.

Vertical Models		Overall Cabinet			Water Connections							Electrical Knockouts		
					1	2	3	4	5	Loop Water FPT	Knockout HWG Provisions	6	7	8
		A Width	B Depth	C Height*	D In	E Out	F HWG In	G HWG Out	H Condensate			J 1/2" cond Low Voltage	K 1/2" cond Low Voltage	L 1" cond Power Supply
009-012	in.	22.5	22.2	30.2	2.6	7.6	N/A	N/A	10.8	1/2"	N/A	9.4	5.4	7.4
	cm.	57.2	56.4	76.7	6.6	19.3	N/A	N/A	27.4	12.7 mm	N/A	23.9	13.7	18.8
015-018	in.	22.5	26.2	40.2	2.6	7.6	1.4	4.4	10.8	3/4"	0.875	10.1	6.1	8.1
	cm.	57.2	66.5	102.1	6.6	19.3	3.6	11.2	27.4	19.1 mm	22.2 mm	25.7	15.5	20.6
024-030	in.	22.5	26.2	44.2	2.6	7.6	1.4	4.4	10.8	3/4"	0.875	10.1	6.1	8.1
	cm.	57.2	66.5	112.3	6.6	19.3	3.6	11.2	27.4	19.1 mm	22.2 mm	25.7	15.5	20.6
036	in.	25.5	31.2	44.2	2.6	7.6	1.4	4.4	10.8	1"	0.875	10.1	6.1	8.1
	cm.	64.8	79.2	112.3	6.6	19.3	3.6	11.2	27.4	25.4 mm	22.2 mm	25.7	15.5	20.6
042-048	in.	25.5	31.2	48.2	2.6	7.6	1.4	4.4	10.8	1"	0.875	10.1	6.1	8.1
	cm.	64.8	79.2	122.4	6.6	19.3	3.6	11.2	27.4	25.4 mm	22.2 mm	25.7	15.5	20.6
060-072	in.	25.5	31.2	52.2	2.6	7.6	1.4	4.4	10.8	1"	0.875	10.1	6.1	8.1
	cm.	64.8	79.2	132.6	6.6	19.3	3.6	11.2	27.4	25.4 mm	22.2 mm	25.7	15.5	20.6

Vertical Models		Discharge Connection duct flange installed (±0.10 in)					**Return Connection using deluxe filter rack (±0.10 in)				
		M	N	P	Q	R	S	T	U	V	W
		Filter Rack Width	Supply Width	Supply Depth					Return Depth	Return Height	
009-012	in.	2.2	10.0	10.0	6.1	5.3	9.8	2.0	18.1	14.0	2.0
	cm.	5.6	25.4	25.4	##	13.5	24.9	5.1	46.0	35.6	5.1
015-018	in.	2.2	14.0	14.0	6.1	4.5	7.7	2.0	22.1	22.0	1.9
	cm.	5.6	35.6	35.6	##	11.4	19.6	5.1	56.1	55.9	4.8
024-030	in.	2.2	14.0	14.0	6.1	4.5	7.7	2.0	22.1	26.1	1.8
	cm.	5.6	35.6	35.6	##	11.4	19.6	5.1	56.1	66.3	4.6
036	in.	2.2	18.0	18.0	6.6	4.6	6.3	1.6	28.1	26.1	2.0
	cm.	5.6	45.7	45.7	##	11.7	16.0	4.1	71.4	66.3	5.1
042-048	in.	2.2	18.0	18.0	6.6	4.6	6.3	1.6	28.1	30.0	2.0
	cm.	5.6	45.7	45.7	##	11.7	16.0	4.1	71.4	76.2	5.1
060-072	in.	2.2	18.0	18.0	6.6	5.0	6.4	1.6	28.1	34.0	2.0
	cm.	5.6	45.7	45.7	##	12.7	16.3	4.1	71.4	86.4	5.1

Condensate is 3/4" PVC female glue socket and is switchable from side to front.

5/7/24

*Discharge flange is field installed and extends 1" (25.4 mm) from top of cabinet.

****Vertical units shipped with standard 2" (field adjustable to 1") open application filter rack extending 2.2" from unit and is not suitable for duct connection, For ductable return connection applications, order the deluxe 2" (field adjustable to 1") duct collar/filter rack which extends 3.25" from the unit and is suitable for duct connections.**

Vertical Disconnect

When using disconnect, do not use dimension L from the standard vertical dimensional data. Use dimension LL from the vertical disconnect dimensional data.

Vertical Models	LL
009-012	17.8 [45.2]
015-018	14.3 [36.3]
024-030	15.3 [38.9]
036-038	14.3 [36.3]
042-049	14.3 [36.3]
060-064	14.3 [36.3]
070-072	External

Dimensions in inches [cm]

3/16/12

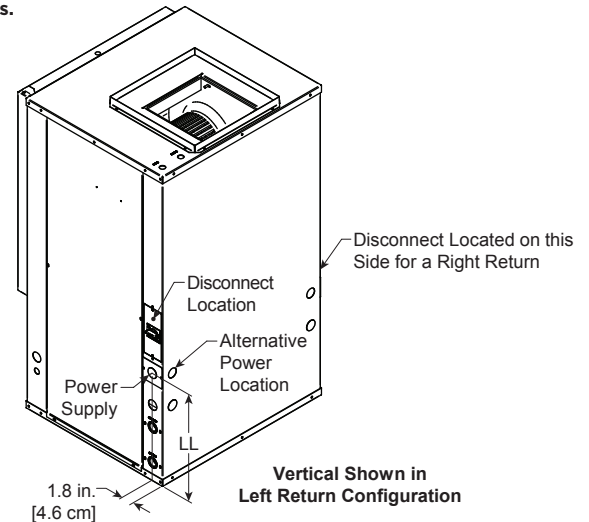

Dimensional Data - Horizontal

HORIZONTAL DIMENSIONAL DATA

Legend	
AP	= Alternate Service Panel
BP	= Blower Service Panel
CP	= Control Access Panel
CMP	= Compressor Service Panel

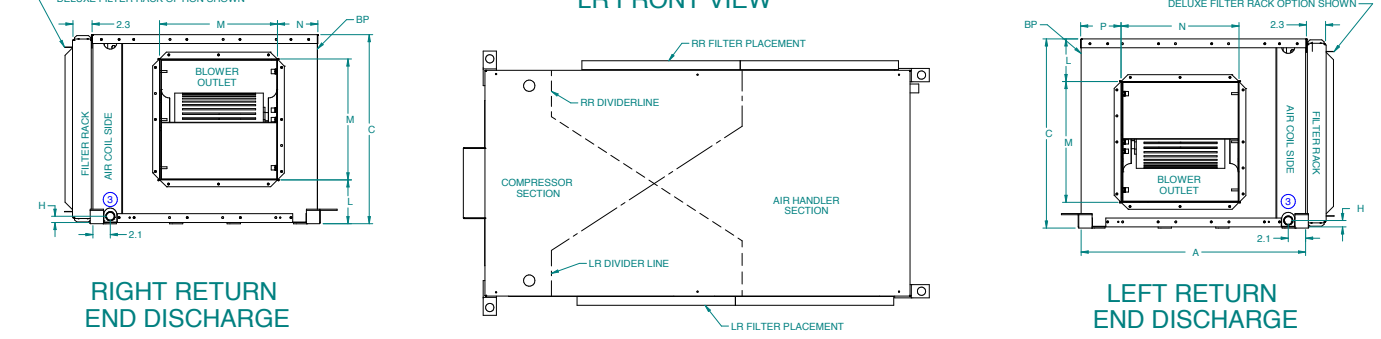
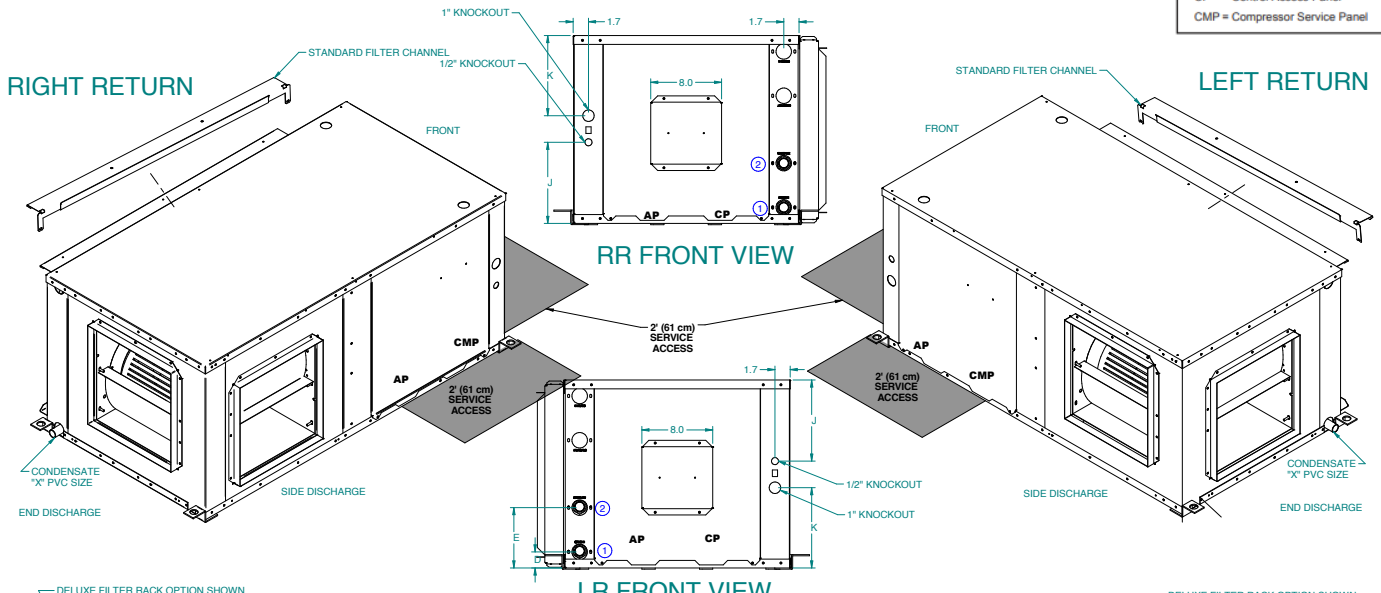

UNIT HANGER DETAIL

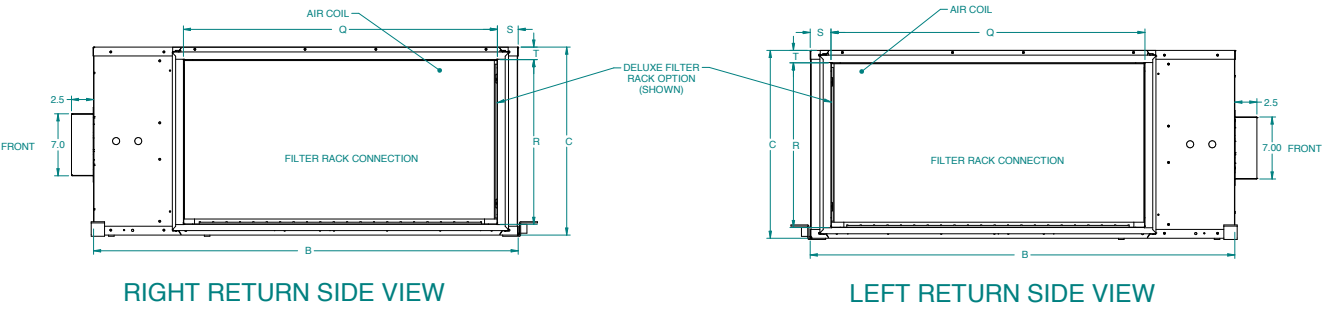
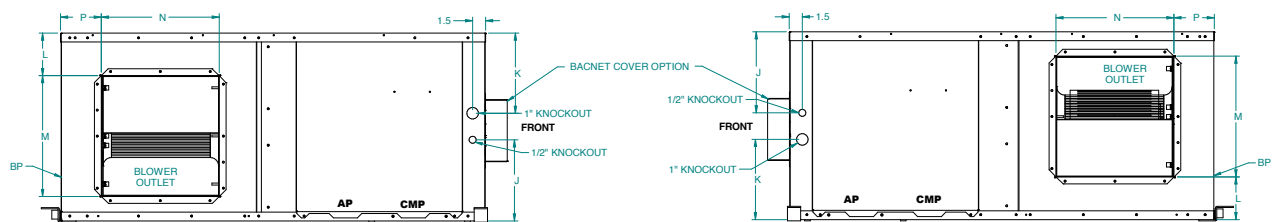

Dimensional Data - Horizontal cont.

Horizontal Models		Overall Cabinet			Water Connections				Electrical Knockouts	
		A	B	C	1	2	3	Loop	J	K
					D	E	H		1/2" cond	1" cond
Width	Depth	Height*	In	Out	Condensate	Water FPT	Low Voltage	Power Supply		
009-012	in.	22.5	35.0	17.2	1.8	6.8	0.8	1/2"	7.1	7.1
	cm.	57.2	88.9	43.7	4.6	17.3	2.0	12.7 mm	18.0	18.0
015-018	in.	22.5	42.0	19.2	1.8	6.8	0.8	3/4"	9.1	7.1
	cm.	57.2	106.7	48.8	4.6	17.3	2.0	19.05 mm	23.1	18.0
024-030	in.	22.5	45.0	19.2	1.8	6.8	0.8	3/4"	9.2	7.1
	cm.	57.2	114.3	48.8	4.6	17.3	2.0	19.05 mm	23.4	18.0
036	in.	25.5	48.0	21.2	1.8	6.8	0.8	1"	9.2	9.1
	cm.	64.8	121.9	53.8	4.6	17.3	2.0	25.4 mm	23.4	23.1
042-048	in.	25.5	53.0	21.2	1.8	6.8	0.8	1"	9.2	9.1
	cm.	64.8	134.6	53.8	4.6	17.3	2.0	25.4 mm	23.4	23.1
060	in.	25.5	61.0	21.2	1.8	6.8	0.8	1"	9.2	9.1
	cm.	64.8	154.9	53.8	4.6	17.3	2.0	25.4 mm	23.4	23.1
072	in.	25.5	68.0	21.2	1.8	6.8	0.8	1"	9.2	9.1
	cm.	64.8	172.7	53.8	4.6	17.3	2.0	25.4 mm	23.4	23.1

Horizontal Models		Discharge Connection duct flange installed (±0.10 in)				Return Connection using deluxe filter rack option (±0.10 in)				Unit Hanger Dimensions			PVC Size
		L	M	N	P	Q	R	S	T	U	V	W	X
			Supply Width	Supply Depth		Return Depth	Return Height						
009-012	in.	5.9	7.2	9.5	6.0	16.4	14.5	2.0	1.4	35.7	25.1	21.4	3/4"
	cm.	15.0	18.3	24.1	15.2	41.7	36.8	5.1	3.6	90.7	63.8	54.4	1.9
015-018	in.	6.7	10.5	9.4	4.9	27.4	16.6	2.0	1.4	42.8	25.1	21.4	3/4"
	cm.	17.0	26.7	23.9	12.4	69.6	42.2	5.1	3.6	108.6	63.8	54.4	1.9
024-030	in.	6.7	10.5	9.4	4.9	30.4	16.6	2.0	1.5	45.8	25.1	21.4	3/4"
	cm.	17.0	26.7	23.9	12.4	77.2	42.2	5.1	3.8	116.3	63.8	54.4	1.9
036	in.	4.9	13.6	13.2	4.6	35.4	18.6	2.3	1.4	48.8	28.1	24.4	3/4"
	cm.	12.4	34.5	33.5	11.7	89.9	47.2	5.8	3.6	124.0	71.4	62.0	1.9
042-048	in.	4.9	13.6	13.2	4.6	40.4	18.6	2.3	1.4	53.8	28.1	24.4	3/4"
	cm.	12.4	34.5	33.5	11.7	102.6	47.2	5.8	3.6	136.7	71.4	62.0	1.9
060	in.	4.9	13.6	13.2	4.6	45.4	18.6	2.3	1.4	61.8	28.1	24.4	3/4"
	cm.	12.4	34.5	33.5	11.7	115.3	47.2	5.8	3.6	157.0	71.4	62.0	1.9
072	in.	4.9	13.6	13.2	4.6	45.4	18.6	2.3	1.4	68.8	28.1	24.4	3/4"
	cm.	12.4	34.5	33.5	11.7	115.3	47.2	5.8	3.6	174.8	71.4	62.0	1.9

5/7/24

Horizontal units shipped with standard 2" (field adjustable to 1") open application filter rack extending 2.2" from unit and is not suitable for duct connection, For ductable return connection applications, order the deluxe 2" (field adjustable to 1") duct collar/filter rack which extends 3.25" from the unit and is suitable for duct connections.

Horizontal Disconnect

When using disconnect, do not use dimension K from the standard horizontal dimensional data. Use dimension KK from the horizontal disconnect dimensional data.

Horizontal Models	KK
009-012	8.2 [20.8]
015-018	9.2 [23.4]
024-030	9.2 [23.4]
036-038	11.2 [28.4]
042-049	10.2 [25.9]
060-064	11.2 [28.4]
070-072	10.2 [25.9]

Dimensions in inches [cm]

3/16/12

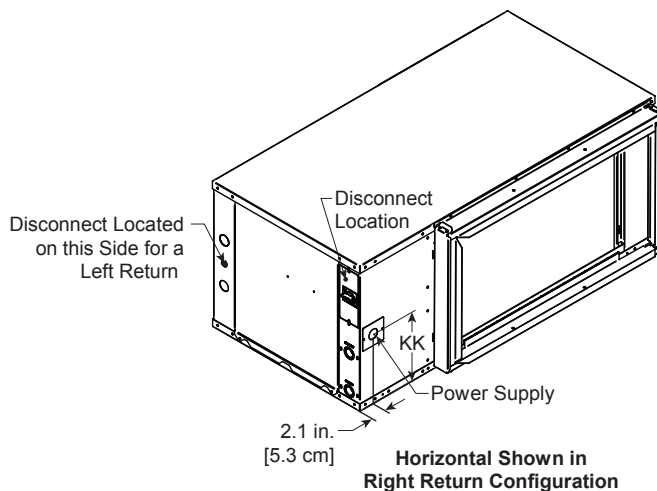

Waterside Economizer Dimensional Data

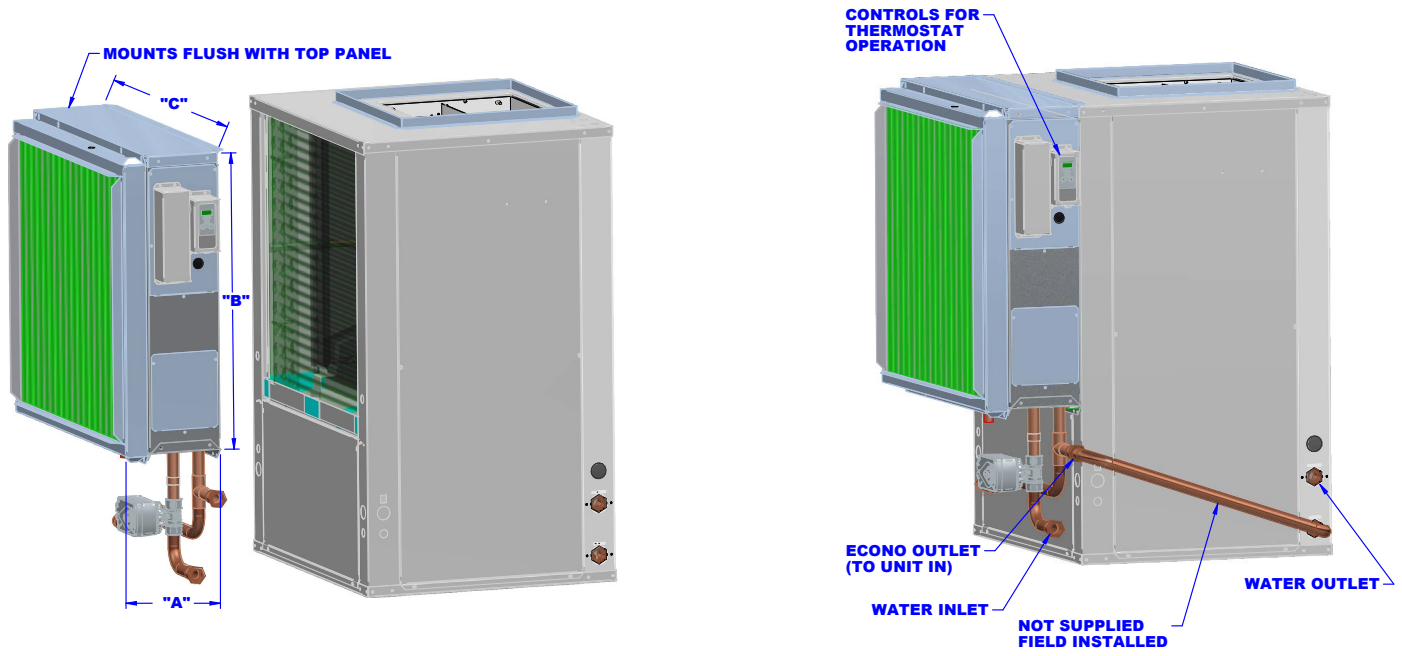

MODEL SERIES	MODEL SERIES	MODEL SERIES	"A"	"B"	"C"	FILTER RACK WIDTH
3V024-030			7.2	22	22.2	2.2
3V036			7.2	26	26.2	2.2
3V042-048	5V024-030	7V024	7.2	30	26.2	2.2
3V060	5V036-038	7V036	7.2	30	31.2	2.2
3V070	5V042-049	7V048	7.2	34	31.2	2.2
	5V060-072	7V060-072	7.2	38	31.2	2.2

Hanger Bracket Locations

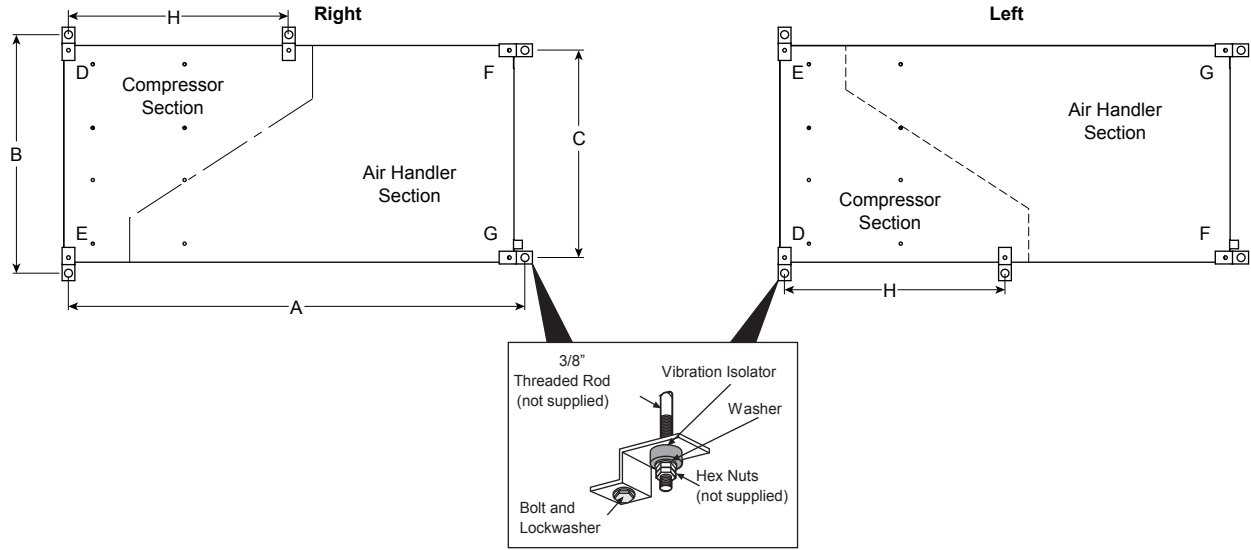

NOTE: Model sizes 070-072 will be shipped with six (6) hanger brackets. Only five (5) hanger brackets will be used on the unit. See the above illustration for the fifth hanger bracket location. All other models will use four (4) hanger brackets.

Hanger Bracket Locations

	Model		Hanger Kit Part Number	Unit Hanger Dimensions			
				A	B	C	D
Single Speed	009-012	in.	99S500A04	35.7	25.1	21.4	n/a
		cm.		90.7	63.8	54.4	n/a
	015-018	in.	99S500A04	42.8	25.1	21.4	n/a
		cm.		108.7	63.8	54.4	n/a
	024-030	in.	99S500A04	45.8	25.1	21.4	n/a
		cm.		116.3	63.8	54.4	n/a
	036	in.	99S500A04	48.8	28.1	24.4	n/a
		cm.		124.0	71.4	62.0	n/a
	042-048	in.	99S500A04	53.8	28.1	24.4	n/a
		cm.		136.7	71.4	62.0	n/a
	060	in.	99S500A04	61.8	28.1	24.4	n/a
		cm.		157.0	71.4	62.0	n/a
	072	in.	99S500A03	68.8	28.1	24.4	34.0
		cm.		174.8	71.4	62.0	74.4
Dual Capacity	018	in.	99S500A04	42.8	25.1	21.4	n/a
		cm.		108.7	63.8	54.4	n/a
	024-030	in.	99S500A04	45.8	25.1	21.4	n/a
		cm.		116.3	63.8	54.4	n/a
	036	in.	99S500A03	48.8	28.1	24.4	n/a
		cm.		124.0	71.4	62.0	n/a
	042-048	in.	99S500A04	53.8	28.1	24.4	n/a
		cm.		136.7	71.4	62.0	n/a
	060	in.	99S500A04	61.8	28.1	24.4	n/a
		cm.		157.0	71.4	62.0	n/a
	072	in.	99S500A03	68.8	28.1	24.4	34.0
		cm.		174.8	71.4	62.0	74.4

4/15/24

Weight Distribution Table

	Model	Vertical Shipping Weight	Horizontal Shipping Weight	Horizontal Weight Distribution			
				Front		Back	
				D	E	F	G
Single Speed	009	171	176	32	67	32	45
		[78]	[80]	[15]	[30]	[15]	[20]
	012	171	176	32	67	32	45
		[78]	[80]	[15]	[30]	[15]	[20]
	015	210	220	65	40	70	35
		[95]	[100]	[29]	[18]	[32]	[16]
	018	210	220	65	40	70	35
		[95]	[100]	[29]	[18]	[32]	[16]
	024	280	295	75	70	75	20
		[127]	[134]	[34]	[31]	[34]	[13]
	030	285	295	75	70	75	30
		[129]	[134]	[34]	[31]	[34]	[13]
	036	300	305	85	80	85	40
		[136]	[138]	[39]	[36]	[39]	[18]
042	365	375	115	95	75	60	
	[166]	[170]	[52]	[43]	[34]	[27]	
048	370	380	120	100	80	65	
	[168]	[172]	[54]	[45]	[36]	[29]	
060	410	420	120	110	95	80	
	[186]	[191]	[54]	[50]	[43]	[36]	
072	445	455	135	120	100	85	
	[202]	[206]	[61]	[54]	[45]	[39]	
Dual Capacity	018	210	220	65	40	70	35
		[95]	[100]	[29]	[18]	[32]	[16]
	024	280	295	75	70	75	20
		[127]	[134]	[34]	[31]	[34]	[13]
	030	285	295	75	70	75	30
		[129]	[134]	[34]	[31]	[34]	[13]
	036	300	305	85	80	85	40
		[136]	[138]	[39]	[36]	[39]	[18]
	042	365	375	115	95	75	60
		[166]	[170]	[52]	[43]	[34]	[27]
	048	370	380	120	100	80	65
		[168]	[172]	[54]	[45]	[36]	[29]
	060	410	420	120	110	95	80
		[186]	[191]	[54]	[50]	[43]	[36]
072	445	455	135	120	100	85	
	[202]	[206]	[61]	[54]	[45]	[39]	

Weights are listed in lbs. [kg].

4/15/24

Electrical Information

WARNING

During repairs to sealed components, all electrical supplies shall be disconnected from the equipment being worked upon prior to any removal of sealed covers, etc. If it is absolutely necessary to have an electrical supply to equipment during servicing, then a permanently operating form of leak detection shall be located at the most critical point to warn of a potentially hazardous situation.

Sealed electrical components shall be replaced.

WARNING

Do not apply any permanent inductive or capacitance loads to the circuit with out ensuring that this will not exceed the permissible voltage and current permitted for the equipment in use.

Intrinsically safe components must be replaced.

Replace components only with parts specified by the manufacturer. Other parts may result in the ignition of refrigerant in the atmosphere from a leak.

NOTE The use of silicon sealant can inhibit the effectiveness of some types of leak detection equipment. Intrinsically safe components do not have to be isolated prior to working on them.

Electrical Availability

VS ECM

Voltage	Static Option	Single Speed Models										Dual Capacity Models								
		009	012	015	018	024	030	036	042	048	060	072	018	024	030	036	042	048	060	072
208-230/60/1	Standard	•	•	•	•	•	•	•	•	•	•	•	•	•	•	•	•	•	•	•
208-230/60/1 w/IntelliStart					•	•	•	•	•	•	•	•	•	•	•	•	•	•	•	•
265/60/1		•	•	•	•	•	•	•						•	•	•				
208-230/60/3 (also w/IntelliStart)						•	•	•	•	•	•	•		•	•	•	•	•	•	•
460/60/3 (also w/IntelliStart)						•	•	•	•	•	•	•		•	•	•	•	•	•	•
208-230/60/1	High							•	•	•						•	•	•		
265/60/1								•	•	•						•	•	•		
208-230/60/3 (w/IntelliStart)									•	•	•					•	•	•		
460/60/3 (w/IntelliStart)									•	•	•					•	•	•		

4/15/24

5-Speed ECM

Voltage	Static Option	Single Speed Models										Dual Capacity Models							
		015	018	024	030	036	042	048	060	072	018	024	030	036	042	048	060	072	
208-230/60/1	Standard	•	•	•	•	•	•	•	•	•	•	•	•	•	•	•	•	•	•
208-230/60/1 w/IntelliStart			•	•	•	•	•	•	•	•	•	•	•	•	•	•	•	•	•
265/60/1		•	•	•	•	•							•	•	•				
208-230/60/3 (also w/IntelliStart)				•	•	•	•	•	•	•	•		•	•	•	•	•	•	•
460/60/3 (also w/IntelliStart)				•	•	•	•	•	•	•	•		•	•	•	•	•	•	•

4/15/24

Electrical Data

5 Speed ECM Motor Single Capacity

Model	Rated Voltage	Voltage Min/Max	Compressor				Blower Motor FLA	Total Unit FLA	Min Circ Amp	Max Fuse/HACR Breaker	SCCR
			MCC	RLA	LRA	LRA**					
015	208-230/60/1	187/253	10.8	7.7	33.0	N/A	4.1	11.8	13.7	20	5kA
	265/60/1	238/292	9.3	6.7	37.0	N/A	3.6	10.3	12.0	15	
018	208-230/60/1	187/253	14.3	10.2	35.0	14.0	4.1	14.3	16.9	25	5kA
	265/60/1	238/292	10.2	7.3	40.0	N/A	3.6	10.9	12.7	20	
024	208-230/60/1	187/253	17.8	11.4	64.4	25.8	4.1	15.5	18.4	25	5kA
	265/60/1	238/292	16.0	10.3	60.5	N/A	3.6	13.9	16.5	25	
	208-230/60/3	187/253	12.0	7.7	59.9	35.9	4.1	11.8	13.7	20	
	460/60/3	414/506	6.0	3.8	32.4	19.4	2.1	5.9	6.9	10/15	
030	208-230/60/1	187/253	19.8	12.7	75.6	30.2	4.1	16.8	20.0	30	5kA
	265/60/1	238/292	18.0	11.5	84.0	N/A	3.6	15.1	18.0	25	
	208-230/60/3	187/253	15.0	9.6	67.7	40.6	4.1	13.7	16.1	25	
	460/60/3	414/506	7.0	4.5	38.1	22.9	2.1	6.6	7.7	10/15	
036	208-230/60/1	187/253	21.0	13.5	82.5	33.0	4.1	17.6	21.0	30	5kA
	265/60/1	238/292	19.0	12.2	83.0	N/A	3.6	15.8	18.9	30	
	208-230/60/3	187/253	20.0	12.8	97.5	58.5	4.1	16.9	20.1	30	
	460/60/3	414/506	8.0	5.1	44.3	26.6	2.1	7.2	8.5	10/15	
042	208-230/60/1	187/253	23.0	14.7	109.0	43.6	7.6	22.3	26.0	40	5kA
	208-230/60/3	187/253	19.0	12.2	102.8	61.7	7.6	19.8	22.9	35	
	460/60/3	414/506	9.0	5.8	50.0	30.0	4.0	9.8	11.3	15	
048	208-230/60/1	187/253	35.0	22.4	126.0	50.4	7.6	30.0	35.6	55	5kA
	208-230/60/3	187/253	20.0	12.8	120.4	72.2	7.6	20.4	23.6	35	
	460/60/3	414/506	9.4	6.0	49.4	29.6	4.0	10.0	11.5	15	
060	208-230/60/1	187/253	37.0	23.7	157.0	62.8	7.6	31.3	37.2	60	5kA
	208-230/60/3	187/253	25.0	16.0	156.4	93.8	7.6	23.6	27.6	40	
	460/60/3	414/506	11.0	7.1	69.0	41.4	4.0	11.1	12.9	15	
072	208-230/60/1	187/253	43.0	27.6	170.0	68.0	7.6	35.2	42.1	60	5kA
	208-230/60/3	187/253	30.0	19.2	156.5	93.9	7.6	26.8	31.6	50	
	460/60/3	414/506	14.0	9.0	74.8	44.9	4.0	13.0	15.3	20	

HACR circuit breaker in USA only
 **With optional IntelliStart

Electrical Data cont.

5 Speed ECM Motor Dual Capacity

Model	Rated Voltage	Voltage Min/Max	Compressor				Blower Motor FLA	Total Unit FLA	Min Circ Amp	Max Fuse/HACR Breaker	SCCR
			MCC	RLA	LRA	LRA**					
018	208-230/60/1	187/253	15.0	9.6	52.0	20.8	4.1	13.7	16.1	25	5kA
024	208-230/60/1	187/253	16.0	10.3	62.0	24.8	4.1	14.4	17.0	25	5kA
	265/60/1	238/292	12.2	7.8	52.0	N/A	3.6	11.4	13.4	20	
	208-230/60/3	187/253	9.8	6.3	56.0	22.4	4.1	10.4	12.0	15	
	460/60/3	414/506	5.9	3.8	29.0	11.6	2.1	5.9	6.9	10/15	
030	208-230/60/1	187/253	22.7	14.5	82.0	32.8	4.1	18.6	22.3	35	5kA
	265/60/1	238/292	18.3	11.7	72.0	N/A	3.6	15.3	18.2	25	
	208-230/60/3	187/253	12.3	7.9	66.0	26.4	4.1	12.0	14.0	20	
	460/60/3	414/506	7.5	4.8	39.0	15.6	2.1	6.9	8.1	10/15	
036	208-230/60/1	187/253	22.7	14.6	90.0	36.0	4.1	18.7	22.4	35	5kA
	265/60/1	238/292	20.3	13.0	72.0	N/A	3.6	16.6	19.9	30	
	208-230/60/3	187/253	15.4	9.9	82.0	32.8	4.1	14.0	16.5	25	
	460/60/3	414/506	7.5	4.8	44.3	17.7	2.1	6.9	8.1	10/15	
042	208-230/60/1	187/253	28.4	18.2	106.0	42.4	7.6	25.8	30.3	45	5kA
	208-230/60/3	187/253	17.9	11.5	114.0	45.6	7.6	19.1	22.0	30	
	460/60/3	414/506	10.1	6.5	56.0	22.4	4.0	10.5	12.1	15	
048	208-230/60/1	187/253	28.6	18.3	138.0	55.2	7.6	25.9	30.5	45	5kA
	208-230/60/3	187/253	18.6	11.9	112.0	44.8	7.6	19.5	22.5	30	
	460/60/3	414/506	10.6	6.8	61.8	24.7	4.0	10.8	12.5	15	
060	208-230/60/1	187/253	39.3	25.2	147.3	58.9	7.6	32.8	39.1	60	5kA
	208-230/60/3	187/253	21.5	13.8	150.0	60.0	7.6	21.4	24.9	35	
	460/60/3	414/506	10.7	6.9	58.0	23.2	4.0	10.9	12.6	15	
072	208-230/60/1	187/253	43.7	28.0	160.0	64.0	7.6	35.6	42.6	70	5kA
	208-230/60/3	187/253	30.0	19.2	162.3	64.9	7.6	26.8	31.6	50	
	460/60/3	414/506	14.2	9.1	70.8	28.3	4.0	13.1	15.4	20	

HACR circuit breaker in USA only
 **With optional IntelliStart

10/15/25

Electrical Data cont.

VS ECM Motor Single Speed

Model	Rated Voltage	Voltage Min/Max	Compressor				Blower Motor FLA	Total Unit FLA	Min Circ Amp	Max Fuse/HACR Breaker	SCCR
			MCC	RLA	LRA	LRA**					
009	208-230/60/1	187/253	8.4	6.0	27.0	N/A	1.1	7.1	8.6	10/15	5kA
	265/60/1	238/292	6.6	4.7	32.0	N/A	1.1	5.8	7.0	10/15	
012	208-230/60/1	187/253	9.5	6.8	27.0	N/A	1.1	7.9	9.4	15	5kA
	265/60/1	238/292	7.3	5.2	32.0	N/A	1.1	6.3	7.6	10/15	
015	208-230/60/1	187/253	10.8	7.7	33.0	N/A	4.0	11.7	13.6	20	5kA
	265/60/1	238/292	9.3	6.7	37.0	N/A	4.1	10.8	12.5	15	
018	208-230/60/1	187/253	14.3	10.2	35.0	14.0	4.0	14.2	16.8	25	5kA
	265/60/1	238/292	10.2	7.3	40.0	N/A	4.1	11.4	13.2	20	
024	208-230/60/1	187/253	17.8	11.4	64.4	25.8	4.0	15.4	18.3	25	5kA
	265/60/1	238/292	16.0	10.3	60.5	N/A	4.1	14.4	17.0	25	
	208-230/60/3	187/253	12.0	7.7	59.9	35.9	4.0	11.7	13.6	20	
	460/60/3	414/506	6.0	3.8	32.4	19.4	4.1	7.9	8.9	10/15	
030	208-230/60/1	187/253	19.8	12.7	75.6	30.2	4.0	16.7	19.9	30	5kA
	265/60/1	238/292	18.0	11.5	84.0	N/A	4.1	15.6	18.5	25	
	208-230/60/3	187/253	15.0	9.6	67.7	40.6	4.0	13.6	16.0	25	
	460/60/3	414/506	7.0	4.5	38.1	22.9	4.1	8.6	9.7	10/15	
036	208-230/60/1	187/253	21.0	13.5	82.5	33.0	4.0	17.5	20.9	30	5kA
	265/60/1	238/292	19.0	12.2	83.0	N/A	4.1	16.3	19.4	30	
	208-230/60/3	187/253	20.0	12.8	97.5	58.5	4.0	16.8	20.0	30	
	460/60/3	414/506	8.0	5.1	44.3	26.6	4.1	9.2	10.5	15	
036*	208-230/60/1	187/253	21.0	13.5	82.5	33.0	7.0	20.5	23.9	35	5kA
	265/60/1	238/292	19.0	12.2	83.0	N/A	6.9	19.1	22.2	30	
	208-230/60/3	187/253	20.0	12.8	97.5	58.5	7.0	19.8	23.0	25	
	460/60/3	414/506	8.0	5.1	44.3	26.6	6.9	12.0	13.3	15	
042	208-230/60/1	187/253	23.0	14.7	109.0	43.6	4.0	18.7	22.4	35	5kA
	208-230/60/3	187/253	19.0	12.2	102.8	61.7	4.0	16.2	19.3	30	
	460/60/3	414/506	9.0	5.8	50.0	30.0	4.1	9.9	11.4	15	
042*	208-230/60/1	187/253	23.0	14.7	109.0	43.6	7.0	21.7	25.4	40	5kA
	208-230/60/3	187/253	19.0	12.2	102.8	61.7	7.0	19.2	22.3	30	
	460/60/3	414/506	9.0	5.8	50.0	30.0	6.9	12.7	14.2	15	
048	208-230/60/1	187/253	35.0	22.4	126.0	50.4	4.0	26.4	32.0	50	5kA
	208-230/60/3	187/253	20.0	12.8	120.4	72.2	4.0	16.8	20.0	30	
	460/60/3	414/506	9.4	6.0	49.4	29.6	4.1	10.1	11.6	15	
048*	208-230/60/1	187/253	35.0	22.4	126.0	50.4	7.0	29.4	35.0	50	5kA
	208-230/60/3	187/253	20.0	12.8	120.4	72.2	7.0	19.8	23.0	35	
	460/60/3	414/506	9.4	6.0	49.4	29.6	6.9	12.9	14.4	20	
060	208-230/60/1	187/253	37.0	23.7	157.0	62.8	7.0	30.7	36.6	60	5kA
	208-230/60/3	187/253	25.0	16.0	156.4	93.8	7.0	23.0	27.0	40	
	460/60/3	414/506	11.0	7.1	69.0	41.4	6.9	14.0	15.8	20	
072	208-230/60/1	187/253	43.0	27.6	170.0	68.0	7.0	34.6	41.5	60	5kA
	208-230/60/3	187/253	30.0	19.2	156.5	93.9	7.0	26.2	31.0	50	
	460/60/3	414/506	14.0	9.0	74.8	44.9	6.9	15.9	18.2	25	

HACR circuit breaker in USA only

*With optional 1 HP ECM motor

**With optional IntelliStart

4/13/26



CAUTION: When installing a unit with a variable speed ECM blower motor in 460/60/3 voltage, a neutral wire is required to allow proper unit operation.

Electrical Data cont.

VS ECM Motor Dual Capacity

Model	Rated Voltage	Voltage Min/Max	Compressor				Blower Motor FLA	Total Unit FLA	Min Circ Amp	Max Fuse/HACR Breaker	SCCR
			MCC	RLA	LRA	LRA**					
018	208-230/60/1	187/253	15.0	9.6	52.0	20.8	4.0	13.6	16.0	25	5kA
024	208-230/60/1	187/253	16.0	10.3	62.0	24.8	4.0	14.3	16.9	25	5kA
	265/60/1	238/292	12.2	7.8	52.0	N/A	4.1	11.9	13.9	20	
	208-230/60/3	187/253	9.8	6.3	56.0	22.4	4.0	10.3	11.9	15	
	460/60/3	414/506	5.9	3.8	29.0	11.6	4.1	7.9	8.9	10/15	
030	208-230/60/1	187/253	22.7	14.5	82.0	32.8	4.0	18.5	22.2	35	5kA
	265/60/1	238/292	18.3	11.7	72.0	N/A	4.1	15.8	18.7	30	
	208-230/60/3	187/253	12.3	7.9	66.0	26.4	4.0	11.9	13.9	20	
	460/60/3	414/506	7.5	4.8	39.0	15.6	4.1	8.9	10.1	10/15	
036	208-230/60/1	187/253	22.7	14.6	90.0	36.0	4.0	18.6	22.3	35	5kA
	265/60/1	238/292	20.3	13.0	72.0	N/A	4.1	17.1	20.4	30	
	208-230/60/3	187/253	15.4	9.9	82.0	32.8	4.0	13.9	16.4	25	
	460/60/3	414/506	7.5	4.8	44.3	17.7	4.1	8.9	10.1	10/15	
036*	208-230/60/1	187/253	22.7	14.6	90.0	36.0	7.0	21.6	25.3	35	5kA
	265/60/1	238/292	20.3	13.0	72.0	N/A	7.0	20.0	23.3	35	
	208-230/60/3	187/253	15.4	9.9	82.0	32.8	7.0	16.9	19.4	25	
	460/60/3	414/506	7.5	4.8	44.3	17.7	6.9	11.7	12.9	15	
042	208-230/60/1	187/253	28.4	18.2	106.0	42.4	4.0	22.2	26.7	40	5kA
	208-230/60/3	187/253	17.9	11.5	114.0	45.6	4.0	15.5	18.4	25	
	460/60/3	414/506	10.1	6.5	56.0	22.4	4.1	10.6	12.2	15	
042*	208-230/60/1	187/253	28.4	18.2	106.0	42.4	7.0	25.2	29.7	45	5kA
	208-230/60/3	187/253	17.9	11.5	114.0	45.6	7.0	18.5	21.4	30	
	460/60/3	414/506	10.1	6.5	56.0	22.4	6.9	13.4	15.0	20	
048	208-230/60/1	187/253	28.6	18.3	138.0	55.2	4.0	22.3	26.9	45	5kA
	208-230/60/3	187/253	18.6	11.9	112.0	44.8	4.0	15.9	18.9	35	
	460/60/3	414/506	10.6	6.8	61.8	24.7	4.1	10.9	12.6	15	
048*	208-230/60/1	187/253	28.6	18.3	138.0	55.2	7.0	25.3	29.9	45	5kA
	208-230/60/3	187/253	18.6	11.9	112.0	44.8	7.0	18.9	21.9	30	
	460/60/3	414/506	10.6	6.8	61.8	24.7	6.9	13.7	15.4	20	
060	208-230/60/1	187/253	39.3	25.2	147.3	58.9	7.0	32.2	38.5	60	5kA
	208-230/60/3	187/253	21.5	13.8	150.0	60.0	7.0	20.8	24.3	35	
	460/60/3	414/506	10.7	6.9	58.0	23.2	6.9	13.8	15.5	20	
072	208-230/60/1	187/253	43.7	28.0	160.0	64.0	7.0	35.0	42.0	60	5kA
	208-230/60/3	187/253	30.0	19.2	162.3	64.9	7.0	26.2	31.0	50	
	460/60/3	414/506	14.2	9.1	70.8	28.3	6.9	16.0	18.3	25	

HACR circuit breaker in USA only

5/17/24

*With optional 1 HP ECM motor

**With optional IntelliStart



CAUTION: When installing a unit with a variable speed ECM blower motor in 460/60/3 voltage, a neutral wire is required to allow proper unit operation.

Blower Performance Data

5-Spd ECM Motor Series Single Speed

Model	Motor Spd	Motor Tap	T'Stat Cnct.	Blower Size	Motor HP	Airflow (cfm) at External Static Pressure (in. wg)															
						0	0.05	0.10	0.15	0.20	0.25	0.30	0.35	0.40	0.45	0.50	0.60	0.70	0.80	0.90	1.00
015	High	5		9 x 7	1/2	916	898	881	866	851	679	813	804	795	774	754	731	695	643	-	-
	Med High	4	W			809	787	765	754	743	725	707	688	669	654	639	606	536	-	-	-
	Med	3				727	715	703	682	661	638	616	601	587	561	536	485	-	-	-	-
	Med Low	2	Y1			699	675	652	631	611	594	577	551	525	490	455	-	-	-	-	-
	Low	1	G			656	604	552	530	508	493	479	436	394	350	-	-	-	-	-	-
018	High	5		9 x 7	1/2	916	898	881	866	851	679	813	804	795	774	754	731	695	643	-	-
	Med High	4	W			809	787	765	754	743	725	707	688	669	654	639	606	536	-	-	-
	Med	3				727	715	703	682	661	638	616	601	587	561	536	485	-	-	-	-
	Med Low	2	Y1			699	675	652	631	611	594	577	551	525	490	455	-	-	-	-	-
	Low	1	G			656	604	552	530	508	493	479	436	394	350	-	-	-	-	-	-
024	High	5	W	9 x 7	1/2	1015	1003	990	975	955	945	935	920	905	890	880	850	825	745	-	-
	Med High	4	Y1			935	915	895	880	875	855	840	825	815	800	785	755	720	580	-	-
	Med	3				865	855	845	825	810	795	780	765	750	735	720	675	610	570	-	-
	Med Low	2	G			810	790	770	755	740	725	710	695	680	660	640	560	530	-	-	-
	Low	1				695	645	595	575	550	520	495	455	420	400	-	-	-	-	-	-
030	High	5		9 x 7	1/2	1407	1381	1354	1327	1300	1267	1233	1201	1168	1131	1094	1009	-	-	-	-
	Med High	4	W			1146	1134	1122	1111	1099	1085	1071	1062	1052	1042	1031	966	-	-	-	-
	Med	3	Y1			1023	1012	1001	985	969	959	949	937	925	913	901	-	-	-	-	-
	Med Low	2				978	962	946	934	922	907	891	882	872	858	843	-	-	-	-	-
	Low	1	G			795	777	759	748	737	718	698	686	673	650	626	-	-	-	-	-
036	High	5	W	11 x 10	1/2	1530	1503	1476	1453	1429	1413	1397	1376	1355	1342	1329	1276	1231	1173	-	-
	Med High	4	Y1			1413	1388	1363	1342	1321	1303	1285	1263	1240	1226	1212	1173	1016	946	-	-
	Med	3				1355	1325	1294	1276	1258	1235	1212	1188	1164	1144	1123	982	909	883	-	-
	Med Low	2				1336	1299	1261	1242	1222	1202	1181	1157	1132	1111	1090	937	874	830	-	-
	Low	1	G			1243	1182	1121	1061	1000	964	928	856	784	744	703	647	592	-	-	-
042	High	5		11 x 10	1	1934	1910	1886	1871	1855	1827	1799	1780	1760	1747	1734	1700	1659	1617	-	-
	Med High	4	W			1799	1783	1767	1744	1720	1693	1666	1649	1631	1617	1603	1560	1530	1492	-	-
	Med	3				1694	1680	1666	1642	1617	1592	1567	1552	1537	1519	1500	1453	1421	1372	-	-
	Med Low	2	Y1			1575	1560	1540	1520	1502	1487	1471	1448	1424	1409	1393	1351	1308	1266	-	-
	Low	1	G			1454	1406	1358	1333	1308	1285	1261	1239	1217	1198	1179	1072	1002	988	-	-
048	High	5		11 x 10	1	1934	1910	1886	1871	1855	1827	1799	1780	1760	1747	1734	1700	1659	1617	-	-
	Med High	4	W			1799	1783	1767	1744	1720	1693	1666	1649	1631	1617	1603	1560	1530	1492	-	-
	Med	3	Y1			1694	1680	1666	1642	1617	1592	1567	1552	1537	1519	1500	1453	1421	1372	-	-
	Med Low	2				1575	1560	1540	1520	1502	1487	1471	1448	1424	1409	1393	1351	1308	1266	-	-
	Low	1	G			1454	1406	1358	1333	1308	1285	1261	1239	1217	1198	1179	1072	1002	988	-	-
060	High	5	W	11 x 10	1	2230	2212	2193	2173	2152	2139	2125	2109	2092	2076	2059	2026	1992	1951	1892	1806
	Med High	4	Y1			2081	2065	2048	2032	2015	1998	1980	1963	1946	1928	1910	1880	1849	1806	1767	1728
	Med	3				1951	1931	1910	1889	1868	1850	1831	1812	1793	1774	1755	1722	1688	1654	1612	1562
	Med Low	2				1812	1790	1767	1748	1728	1708	1688	1671	1654	1640	1626	1584	1547	1510	1472	1417
	Low	1	G			1668	1651	1633	1612	1591	1566	1540	1525	1510	1491	1472	1433	1400	1351	1299	1208
072	High	5	W	11 x 10	1	2472	2454	2435	2414	2393	2371	2349	2328	2306	2289	2271	2236	2189	2121	2033	1936
	Med High	4	Y1			2271	2248	2225	2205	2184	2166	2147	2129	2110	2094	2078	2039	2011	1977	1930	1846
	Med	3				2133	2115	2096	2072	2047	2030	2013	1996	1979	1965	1950	1909	1873	1837	1793	1748
	Med Low	2				2008	1985	1962	1939	1915	1898	1880	1862	1843	1828	1812	1774	1742	1703	1669	1635
	Low	1	G			1806	1784	1761	1742	1722	1696	1669	1656	1642	1625	1607	1564	1527	1490	1443	1404

Factory settings are in Bold

5/7/24

Air flow values are with dry coil and standard 1" filter

About 5-Speed ECM Constant Speed Motors

The 5-speed ECM is a 'Constant Speed' ECM motor and delivers air flow similar to a PSC but operates as efficiently as a variable speed ECM motor. Because it is an ECM motor, the 5-speed ECM can ramp slowly up or down like the variable speed ECM motor. There are 5 possible speed taps available on the 5-speed ECM motor with #1 being the lowest airflow and #5 being the highest airflow. These speed selections are preset at the time of manufacture and are easily changed in the field if necessary.

If more than one tap are energized at the same time, built in logic gives precedence to the highest tap number and allows air flow to change with G, Y1, Y2 and W signals. Each of those 5 speeds has a specific 'Speed' value programmed into the motor for each speed selection.

As static pressure increases, airflow decreases resulting in less speed on the rotor. The motor responds only to changes in speed and adjusts its speed accordingly.

The 5-speed ECM motor is powered by line voltage but the motor speed is energized by 24VAC.

5-Speed ECM Benefits:

- High efficiency
- Soft start
- 5 speeds with up to 4 speeds on-line
- Built in logic allows air flow to change with G, Y1, Y2 and W signals
- Super efficient low airflow continuous blower setting (G)

Blower Performance Data cont.

Dual Capacity

Model	Motor Speed	Motor Tap	T'stat Connection	Blower Size	Motor HP	Airflow (cfm) at External Static Pressure (in. wg)															
						0	0.05	0.10	0.15	0.20	0.25	0.30	0.35	0.40	0.45	0.50	0.60	0.70	0.80	0.90	1.00
018	High	5	W	9 x 7	1/2	916	898	881	866	851	679	813	804	795	774	754	731	695	643	-	-
	Med High	4				809	787	765	754	743	725	707	688	669	654	639	606	536	-	-	-
	Med	3	727			715	703	682	661	638	616	601	587	561	536	485	-	-	-	-	-
	Med Low	2	699			675	652	631	611	594	577	551	525	490	455	-	-	-	-	-	-
	Low	1	656			604	552	530	508	493	479	436	394	350	-	-	-	-	-	-	-
024	High	5	W	9 x 7	1/2	1015	1003	990	975	955	945	935	920	905	890	880	850	825	745	-	-
	Med High	4	935			915	895	880	875	855	840	825	815	800	785	755	720	580	-	-	-
	Med	3	865			855	845	825	810	795	780	765	750	735	720	675	610	570	-	-	-
	Med Low	2	810			790	770	755	740	725	710	695	680	660	640	560	530	-	-	-	-
	Low	1	695			645	595	575	550	520	495	455	420	400	-	-	-	-	-	-	-
030	High	5	W	9 x 7	1/2	1407	1381	1354	1327	1300	1267	1233	1201	1168	1131	1094	1009	-	-	-	-
	Med High	4				1146	1134	1122	1111	1099	1085	1071	1062	1052	1042	1031	966	-	-	-	-
	Med	3	1023			1012	1001	985	969	959	949	937	925	913	901	-	-	-	-	-	-
	Med Low	2	978			962	946	934	922	907	891	882	872	858	843	-	-	-	-	-	-
	Low	1	795			777	759	748	737	718	698	686	673	650	626	-	-	-	-	-	-
036	High	5	W	11 x 10	1/2	1530	1503	1476	1453	1429	1413	1397	1376	1355	1342	1329	1276	1231	1173	-	-
	Med High	4	1413			1388	1363	1342	1321	1303	1285	1263	1240	1226	1212	1173	1016	946	-	-	
	Med	3	1355			1325	1294	1276	1258	1235	1212	1188	1164	1144	1123	982	909	883	-	-	
	Med Low	2	1336			1299	1261	1242	1222	1202	1181	1157	1132	1111	1090	937	874	830	-	-	
	Low	1	1243			1182	1121	1061	1000	964	928	856	784	744	703	647	592	-	-	-	-
042	High	5	W	11 x 10	1	1934	1910	1886	1871	1855	1827	1799	1780	1760	1747	1734	1700	1659	1617	-	-
	Med High	4				1799	1783	1767	1744	1720	1693	1666	1649	1631	1617	1603	1560	1530	1492	-	-
	Med	3	1694			1680	1666	1642	1617	1592	1567	1552	1537	1519	1500	1453	1421	1372	-	-	
	Med Low	2	1575			1560	1540	1520	1502	1487	1471	1448	1424	1409	1393	1351	1308	1266	-	-	
	Low	1	1454			1406	1358	1333	1308	1285	1261	1239	1217	1198	1179	1072	1002	988	-	-	-
048	High	5	W	11 x 10	1	1934	1910	1886	1871	1855	1827	1799	1780	1760	1747	1734	1700	1659	1617	-	-
	Med High	4				1799	1783	1767	1744	1720	1693	1666	1649	1631	1617	1603	1560	1530	1492	-	-
	Med	3	1694			1680	1666	1642	1617	1592	1567	1552	1537	1519	1500	1453	1421	1372	-	-	
	Med Low	2	1575			1560	1540	1520	1502	1487	1471	1448	1424	1409	1393	1351	1308	1266	-	-	
	Low	1	1454			1406	1358	1333	1308	1285	1261	1239	1217	1198	1179	1072	1002	988	-	-	-
060	High	5	W	11 x 10	1	2230	2212	2193	2173	2152	2139	2125	2109	2092	2076	2059	2026	1992	1951	1892	1806
	Med High	4	2081			2065	2048	2032	2015	1998	1980	1963	1946	1928	1910	1880	1849	1806	1767	1728	
	Med	3	1951			1931	1910	1889	1868	1850	1831	1812	1793	1774	1755	1722	1688	1654	1612	1562	
	Med Low	2	1812			1790	1767	1748	1728	1708	1688	1671	1654	1640	1626	1584	1547	1510	1472	1417	
	Low	1	1668			1651	1633	1612	1591	1566	1540	1525	1510	1491	1472	1433	1400	1351	1299	1208	
072	High	5	W	11 x 10	1	2472	2454	2435	2414	2393	2371	2349	2328	2306	2289	2271	2236	2189	2121	2033	1936
	Med High	4	2271			2248	2225	2205	2184	2166	2147	2129	2110	2094	2078	2039	2011	1977	1930	1846	
	Med	3	2133			2115	2096	2072	2047	2030	2013	1996	1979	1965	1950	1909	1873	1837	1793	1748	
	Med Low	2	2008			1985	1962	1939	1915	1898	1880	1862	1843	1828	1812	1774	1742	1703	1669	1635	
	Low	1	1806			1784	1761	1742	1722	1696	1669	1656	1642	1625	1607	1564	1527	1490	1443	1404	

Factory speed settings are in Bold

Air flow values are with dry coil and standard filter

For wet coil performance first calculate the face velocity of the air coil (Face Velocity [fpm] = Airflow [cfm] / Face Area [sq ft]).

Then for velocities of 200 fpm reduce the static capability by 0.03 in. wg, 300 fpm by 0.08 in. wg, 400 fpm by 0.12 in. wg., and 500 fpm by 0.16 in. wg.

Highest setting is for auxiliary heat (W) and lowest setting is for constant blower (G). The "Y1" and "Y2" settings must be between the "G" and "W" settings.

5/7/24

Setting Blower Speed - 5-Speed ECM

5-speed ECM blower motors have five (5) speeds of which three (3) are selectable on single speed and four (4) are selectable on dual capacity.



CAUTION: Disconnect all power before performing this operation.

5-Speed ECM Motor Connections - Single Speed

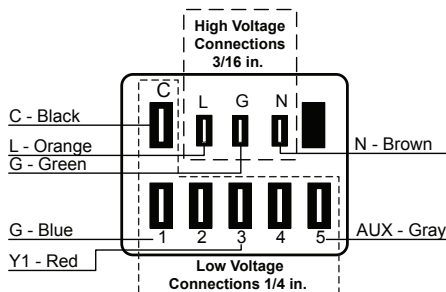

5-Speed ECM Motor Connections - Dual Capacity

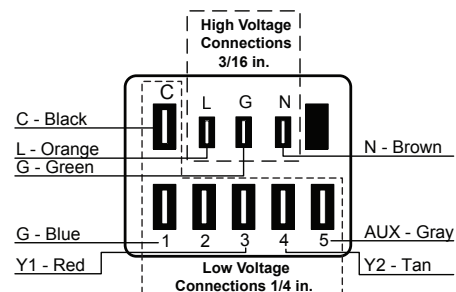

Blower Performance Data cont.

VS ECM Single Speed

Model	Max ESP	Blower Size	Motor hp	Airflow DIP Switch Settings											
				1	2	3	4	5	6	7	8	9	10	11	12
015	0.50	9 x 7	1/2	300	400 L	500	600 M	700 H							
018	0.50	9 x 7	1/2	300	400 L	500	600 M	700 H	800						
024	0.50	9 x 7	1/2		400	500 L	600 M	700 H	800 H	900	1000	1100	1200		
030	0.50	9 x 7	1/2		400	500 L	600	700 M	800 H	900 H	1000	1100	1200		
036	0.50	11 x 10	1/2	650	750	850 L	1000	1100 M	1200 H	1300 H	1400	1500			
036 w/1hp*	0.75	11 x 10	1	800	1000 L	1100 M	1300 H	1500	1600	1800					
042	0.50	11 x 10	1/2	650	800	900 L	1050	1150 M	1250 H	1350	1450 H	1550			
042 w/1hp*	0.75	11 x 10	1	800	900 L	1000	1200 M	1400 H	1600	1700	1850	2000	2200	2300	2400
048	0.50	11 x 10	1/2	650	800	900	1050 L	1150	1250 H	1350 M	1450 H	1550 H			
048 w/1hp*	0.75	11 x 10	1	800	900	1000 L	1200	1400 M	1600 H	1700	1850	2000	2200	2300	2400
060	0.75	11 x 10	1	800	950	1100 L	1300	1500 M	1750 H	1950 H	2100	2300			
072	0.75	11 x 10	1	800	950	1100 L	1300	1500 M	1750 H	1950 H	2100 H	2300			

1/25/24

VS ECM Dual Capacity

Model	Max ESP	AIR FLOW SPEED SETTINGS													
		1	2	3	4	5	6	7	8	9	10	11	12		
018	0.50	300	400 G	500	600 L	700 H	800	875	950	1025	1125 Aux				
024	0.50		400	500 G	600	700 L	800	900 H	1000	1100	1200 Aux				
030	0.50		400	500 G	600	700 L	800	900 H	1000	1100	1200 Aux				
036	0.50	650	750 G	850	1000	1100 L	1200	1300 H	1400	1500	1550 Aux				
042	0.50	650	800	900 G	1050	1150 L	1250	1350 H	1450 H	1550	1600 Aux				
048	0.50	650	800 G	900	1050	1150	1250	1350 L	1450 H	1550 H	1575 Aux				
060	0.75	800	950 G	1100	1300	1500 L	1750 H	1950 H	2100	2300	2325 Aux				
072	0.75	800	950 G	1100	1300	1500 L	1750 L	1950 H	2100 H	2300	2325 Aux				

1/25/24

Factory settings are at recommended G-L-H-Aux speed settings

L-H settings MUST be located within boldface CFM range

"Aux" is factory setting for auxiliary heat and must be equal to or above the "H" setting as well as at least the minimum required for the auxiliary heat package

"G" may be located anywhere within the airflow table

CFM is controlled within ±5% up to the maximum ESP

Max ESP includes allowance for wet coil and standard filter

Factory settings are at recommended L-M-H DIP switch locations

M-H settings MUST be located within boldface CFM range

Lowest and Highest DIP switch settings are assumed to be L and H respectively

CFM is controlled within ±5% up to the maximum ESP

Max ESP includes allowance for wet coil and 1" MERV 4

Blower Performance Data cont.

Variable Speed Constant Speed ECM 009-012 Models

Fan Speed	Fan RPM	Airflow [cfm] at External Static Pressure [in. wg.]						
		0.0	0.1	0.2	0.3	0.4	0.5	0.6
1	0							
2	420	110	65					
3	550	160	115					
4	740	240	135					
5	900	300	200					
6	1075	365	295	215	150			
7	1200	420	355	280	220			
8	1330	465	410	345	275	220		
9	1485	535	485	430	360	310		
10	1650	580	570	520	470	415	345	
11	1750				520	475	410	345
12	1800				525	500	440	370

Air flow values are with dry coil and standard 1" filter

3/30/26

Setting Blower Speed - Variable Speed ECM

The ABC board's Yellow Config LED will flash the current variable speed ECM blower speed selections for low, med, and high continuously with a short pause in between. The speeds can also be confirmed with the AID Tool under the Setup/ECM Setup screen. The variable speed ECM blower motor speeds can be field adjusted with or without using an AID Tool.

Variable Speed ECM Setup without an AID Tool

The blower speeds for Low (G only), Med (Y1), and High (Y2/Aux) can be adjusted directly at the Aurora® ABC board which utilizes the push button (SW1) on the ABC board. This procedure is outlined in the Variable Speed ECM Configuration Mode portion of the Aurora® 'Base' Control System section.

Variable Speed ECM Setup with an AID Tool

A much easier method utilizes the AID Tool to change the airflow using the procedure below. First navigate to the Setup screen and then select ECM Setup. This screen displays the current variable speed ECM settings. It allows the technician to enter the setup screens to change the variable speed ECM settings. Change the highlighted item using the ◀ and ▶ buttons and then press the ◻ button to select the item.

Variable Speed ECM Setup with an AID Tool cont.

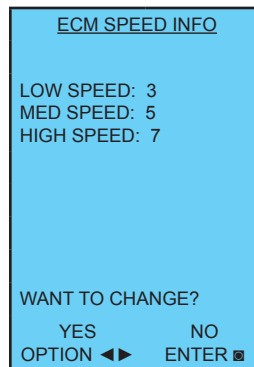

Selecting YES will enter variable speed ECM speed setup, while selecting NO will return to the previous screen.

Variable Speed ECM Speed Setup - These screens allow the technician to select the low, medium, and high blower speed for the variable speed ECM blower motor. Change the highlighted item using the ▲ and ▼ buttons. Press the ◻ button to select the speed.

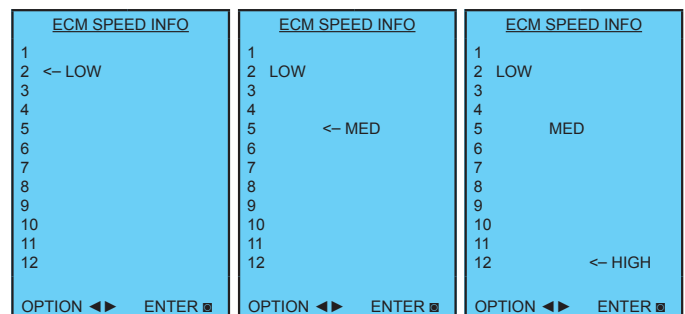

After the high speed setting is selected the AID Tool will automatically transfer back to the ECM Setup screen.

Antifreeze Corrections

Catalog performance can be corrected for antifreeze use. Please use the following table and note the example given.

Antifreeze Type	Antifreeze % by wt	Cooling Capacity	Heating Capacity	Pressure Drop
EWT - degF [DegC]		90 [32.2]	30 [-1.1]	30 [-1.1]
Water	0	1.000	1.000	1.000
Ethylene Glycol	10	0.991	0.973	1.075
	20	0.979	0.943	1.163
	30	0.965	0.917	1.225
	40	0.955	0.890	1.324
	50	0.943	0.865	1.419
Propylene Glycol	10	0.981	0.958	1.130
	20	0.969	0.913	1.270
	30	0.950	0.854	1.433
	40	0.937	0.813	1.614
	50	0.922	0.770	1.816
Ethanol	10	0.991	0.927	1.242
	20	0.972	0.887	1.343
	30	0.947	0.856	1.383
	40	0.930	0.815	1.523
	50	0.911	0.779	1.639
Methanol	10	0.986	0.957	1.127
	20	0.970	0.924	1.197
	30	0.951	0.895	1.235
	40	0.936	0.863	1.323
	50	0.920	0.833	1.399

Warning: Gray area represents antifreeze concentrations greater than 35% by weight and should be avoided due to the extreme performance penalty they represent.

Antifreeze Correction Example

Antifreeze solution is Propylene Glycol 20% by weight. Determine the corrected heating and cooling performance at 30°F and 90°F respectively as well as pressure drop at 30°F for manufacturers heat pump.

The corrected cooling capacity at 90°F would be: 24,300 Btu/h x 0.969 = 23,547 Btu/h

The corrected heating capacity at 30°F would be: 18,900 Btu/h x 0.913 = 17,256 Btu/h

The corrected pressure drop at 30°F and 6 gpm would be: 9.5 ft. hd x 1.270 = 12.07 ft. hd.

Correction Factor Tables

Cooling Capacity Corrections

Entering Air WB °F	Total Clg Cap	Sensible Cooling Capacity Multipliers - Entering DB °F										Power Input	Heat of Rejection
		60	65	70	75	80	80.6	85	90	95	100		
55	0.898	0.723	0.866	1.048	1.185	*	*	*	*	*	*	0.985	0.913
60	0.912		0.632	0.880	1.078	1.244	1.260	*	*	*	*	0.994	0.927
65	0.967			0.694	0.881	1.079	1.085	1.270	*	*	*	0.997	0.972
66.2	0.983			0.655	0.842	1.040	1.060	1.232	*	*	*	0.999	0.986
67	1.000			0.616	0.806	1.000	1.023	1.193	1.330	*	*	1.000	1.000
70	1.053				0.693	0.879	0.900	1.075	1.250	1.404	*	1.003	1.044
75	1.168					0.687	0.715	0.875	1.040	1.261	1.476	1.007	1.141

NOTE: *Sensible capacity equals total capacity at conditions shown.

11/10/09

Heating Corrections

Ent Air DB °F	Htg Cap	Power	Heat of Ext
45	1.062	0.739	1.158
50	1.050	0.790	1.130
55	1.037	0.842	1.096
60	1.025	0.893	1.064
65	1.012	0.945	1.030
68	1.005	0.976	1.012
70	1.000	1.000	1.000
75	0.987	1.048	0.970
80	0.975	1.099	0.930

11/10/09

Airflow Corrections

Airflow		Cooling				Heating		
cfm Per Ton of Clg	% of Nominal	Total Cap	Sens Cap	Power	Heat of Rej	Htg Cap	Power	Heat of Ext
240	60	0.922	0.786	0.910	0.920	0.943	1.150	0.893
275	69	0.944	0.827	0.924	0.940	0.958	1.105	0.922
300	75	0.959	0.860	0.937	0.955	0.968	1.078	0.942
325	81	0.971	0.894	0.950	0.967	0.977	1.053	0.959
350	88	0.982	0.929	0.964	0.978	0.985	1.031	0.973
375	94	0.992	0.965	0.982	0.990	0.993	1.014	0.988
400	100	1.000	1.000	1.000	1.000	1.000	1.000	1.000
425	106	1.007	1.034	1.020	1.010	1.007	0.990	1.011
450	113	1.012	1.065	1.042	1.018	1.013	0.983	1.020
475	119	1.017	1.093	1.066	1.026	1.018	0.980	1.028
500	125	1.019	1.117	1.092	1.033	1.023	0.978	1.034
520	130	1.020	1.132	1.113	1.038	1.026	0.975	1.038

11/10/09

Water Quality

In ground water situations where scaling could be heavy or where biological growth such as iron bacteria will be present, a closed loop system is recommended. The heat exchanger coils in ground water systems may, over a period of time, lose heat exchange capabilities due to a buildup of mineral deposits inside. These can be cleaned, but only by a qualified service mechanic, as special solutions and pumping equipment are required. Hot water generator coils can likewise become scaled and possibly plugged.

In areas with extremely hard water, the owner should be informed that the heat exchanger may require occasional flushing. Failure to adhere to the guidelines in the water quality table could result in loss of warranty.

Units with cupronickel heat exchangers are recommended for open loop applications due to the increased resistance to build-up and corrosion, along with reduced wear caused by acid cleaning.

Material		Copper	90/10 Cupronickel	316 Stainless Steel
pH	Acidity/Alkalinity	7 - 9	7 - 9	7 - 9
Scaling	Calcium and Magnesium Carbonate	(Total Hardness) less than 350 ppm	(Total Hardness) less than 350 ppm	(Total Hardness) less than 350 ppm
Corrosion	Hydrogen Sulfide	Less than 0.5 ppm (rotten egg smell appears at 0.5 ppm)	10 - 50 ppm	Less than 1 ppm
	Sulfates	Less than 125 ppm	Less than 125 ppm	Less than 200 ppm
	Chlorine	Less than 0.5 ppm	Less than 0.5 ppm	Less than 0.5 ppm
	Chlorides	Less than 20 ppm	Less than 125 ppm	Less than 300 ppm
	Carbon Dioxide	Less than 50 ppm	10 - 50 ppm	10 - 50 ppm
	Ammonia	Less than 2 ppm	Less than 2 ppm	Less than 20 ppm
	Ammonia Chloride	Less than 0.5 ppm	Less than 0.5 ppm	Less than 0.5 ppm
	Ammonia Nitrate	Less than 0.5 ppm	Less than 0.5 ppm	Less than 0.5 ppm
	Ammonia Hydroxide	Less than 0.5 ppm	Less than 0.5 ppm	Less than 0.5 ppm
	Ammonia Sulfate	Less than 0.5 ppm	Less than 0.5 ppm	Less than 0.5 ppm
	Total Dissolved Solids (TDS)	Less than 1000 ppm	1000 - 1500 ppm	1000 - 1500 ppm
	LSI Index	+0.5 to -0.5	+0.5 to -0.5	+0.5 to -0.5
Iron Fouling (Biological Growth)	Iron, FE ²⁺ (Ferrous) Bacterial Iron Potential	< 0.2 ppm	< 0.2 ppm	< 0.2 ppm
	Iron Oxide	Less than 1 ppm, above this level deposition will occur	Less than 1 ppm, above this level deposition will occur	Less than 1 ppm, above this level deposition will occur
Erosion	Suspended Solids	Less than 10 ppm and filtered for max. of 600 micron size	Less than 10 ppm and filtered for max. of 600 micron size	Less than 10 ppm and filtered for max. of 600 micron size
	Threshold Velocity (Fresh Water)	< 6 ft/sec	< 6 ft/sec	< 6 ft/sec

NOTES: Grains = ppm divided by 17
mg/L is equivalent to ppm

2/22/12

Operating Limits

Operating Limits	Cooling		Heating	
	(°F)	(°C)	(°F)	(°C)
Air Limits				
Min. Ambient Air	45	7.2	45	7.2
Rated Ambient Air	80	26.7	70	21.1
Max. Ambient Air	100	37.8	85	29.4
Min. Entering Air	50	10.0	40	4.4
Rated Entering Air db/wb	80.6/66.2	27/19	68	20.0
Max. Entering Air db/wb	110/83	43/28.3	80	26.7
Water Limits				
Min. Entering Water	30	-1.1	20	-6.7
Normal Entering Water	50-110	10-43.3	30-70	-1.1
Max. Entering Water	120	48.9	90	32.2

NOTE: Minimum/maximum limits are only for start-up conditions, and are meant for bringing the space up to occupancy temperature. Units are not designed to operate at the minimum/maximum conditions on a regular basis. The operating limits are dependent upon three primary factors: 1) water temperature, 2) return air temperature, and 3) ambient temperature. When any of the factors are at the minimum or maximum levels, the other two factors must be at the normal level for proper and reliable unit operation.

Operating Parameters

Single Speed Models

Entering Water Temp °F	Water Flow gpm/ton	Cooling -- No Hot Water Generation					
		Suction Pressure psig	Discharge Pressure psig	Superheat	Subcooling	Water Temp Rise °F	Air Temp Drop °F DB
30	1.5	115 - 125	150 - 170	20 - 35	10 - 17	17 - 22	17 - 23
	3.0	105 - 120	130 - 145	20 - 35	10 - 17	8 - 10	17 - 23
50	1.5	130 - 140	215 - 235	12 - 20	8 - 14	16 - 22	17 - 23
	3.0	128 - 138	190 - 210	12 - 20	8 - 14	8 - 12	17 - 23
70	1.5	138 - 148	280 - 310	10 - 16	10 - 16	15 - 21	17 - 23
	3.0	136 - 146	250 - 280	10 - 16	8 - 14	7 - 13	17 - 23
90	1.5	145 - 155	350 - 380	9 - 14	10 - 16	14 - 20	17 - 23
	3.0	143 - 153	320 - 350	9 - 14	8 - 14	6 - 10	17 - 23
110	1.5	145 - 155	420 - 450	9 - 14	10 - 16	14 - 20	17 - 23
	3.0	143 - 153	405 - 435	9 - 14	8 - 14	6 - 10	17 - 23

Entering Water Temp °F	Water Flow gpm/ton	Heating - No Hot Water Generation					
		Suction Pressure psig	Discharge Pressure psig	Superheat	Subcooling	Water Temp Drop °F	Air Temp Rise °F DB
30	1.5	73 - 85	270 - 305	8 - 14	3 - 10	6 - 10	15 - 21
	3.0	77 - 90	280 - 315	8 - 14	3 - 10	4 - 8	17 - 23
50	1.5	97 - 110	290 - 325	10 - 16	3 - 10	9 - 13	22 - 28
	3.0	102 - 115	300 - 335	10 - 16	3 - 10	7 - 11	24 - 30
70	1.5	130 - 145	320 - 355	13 - 19	3 - 10	10 - 14	30 - 36
	3.0	135 - 150	325 - 360	13 - 19	3 - 10	8 - 12	32 - 38
90	1.5	150 - 160	350 - 390	13 - 19	3 - 10	10 - 14	30 - 36
	3.0	155 - 165	365 - 405	13 - 19	3 - 10	8 - 12	32 - 38
110	1.5						
	3.0						

NOTE: Cooling performance based on entering air temperatures of 80° F DB, 67° F WB.
Heating performance based on entering air temperature of 70° F DB.

2/15/12

Operating Parameters

Dual Capacity Models

First Stage Operation

Entering Water Temp °F	Water Flow gpm/ton	Cooling -- No Hot Water Generation					
		Suction Pressure psig	Discharge Pressure psig	Superheat	Subcooling	Water Temp Rise °F	Air Temp Drop °F DB
30	1.5	105 - 120	140 - 155	20 - 35	9 - 17	17 - 21	17 - 23
	3.0	100 - 115	115 - 130	20 - 35	9 - 17	8 - 12	17 - 23
50	1.5	125 - 140	205 - 225	12 - 20	8 - 14	17 - 21	17 - 23
	3.0	120 - 135	180 - 200	12 - 20	8 - 14	8 - 12	17 - 23
70	1.5	135 - 145	280 - 290	10 - 16	8 - 14	16 - 20	17 - 23
	3.0	133 - 143	250 - 260	10 - 16	8 - 14	9 - 13	17 - 23
90	1.5	142 - 152	345 - 355	8 - 12	8 - 14	14 - 20	17 - 23
	3.0	140 - 150	330 - 340	8 - 12	8 - 14	8 - 12	17 - 23
110	1.5	152 - 158	405 - 435	8 - 12	8 - 14	14 - 20	17 - 23
	3.0	148 - 153	390 - 420	8 - 12	8 - 14	8 - 12	17 - 23

Entering Water Temp °F	Water Flow gpm/ton	Heating -- No Hot Water Generation					
		Suction Pressure psig	Discharge Pressure psig	Superheat	Subcooling	Water Temp Drop °F	Air Temp Rise °F DB
30	1.5	76 - 84	270 - 285	8 - 12	3 - 10	5 - 9	12 - 16
	3.0	80 - 88	275 - 290	8 - 12	3 - 10	3 - 7	14 - 18
50	1.5	100 - 115	280 - 310	10 - 14	3 - 10	7 - 11	18 - 22
	3.0	105 - 120	290 - 315	10 - 14	3 - 10	5 - 9	20 - 24
70	1.5	135 - 150	310 - 325	12 - 16	3 - 10	8 - 12	24 - 28
	3.0	140 - 155	315 - 330	12 - 16	3 - 10	6 - 10	22 - 30
90	1.5	155 - 165	330 - 370	12 - 16	3 - 10	8 - 12	24 - 28
	3.0	160 - 170	340 - 380	12 - 16	3 - 10	6 - 10	22 - 30
110	1.5						
	3.0						

NOTE: Cooling performance based on entering air temperatures of 80° F DB, 67° F WB.
Heating performance based on entering air temperature of 70° F DB.

2/15/12

Second Stage Operation

Entering Water Temp °F	Water Flow gpm/ton	Cooling -- No Hot Water Generation					
		Suction Pressure psig	Discharge Pressure psig	Superheat	Subcooling	Water Temp Rise °F	Air Temp Drop °F DB
30	1.5	115 - 125	150 - 170	20 - 35	10 - 17	17 - 22	17 - 23
	3.0	105 - 120	130 - 145	20 - 35	10 - 17	8 - 10	17 - 23
50	1.5	130 - 140	215 - 235	12 - 20	8 - 14	16 - 22	17 - 23
	3.0	128 - 138	190 - 210	12 - 20	8 - 14	8 - 12	17 - 23
70	1.5	138 - 148	280 - 310	10 - 16	10 - 16	15 - 21	17 - 23
	3.0	136 - 146	250 - 280	10 - 16	8 - 14	7 - 13	17 - 23
90	1.5	145 - 155	350 - 380	9 - 14	10 - 16	14 - 20	17 - 23
	3.0	143 - 153	320 - 350	9 - 14	8 - 14	6 - 10	17 - 23
110	1.5	145 - 155	420 - 450	9 - 14	10 - 16	14 - 20	17 - 23
	3.0	143 - 153	405 - 435	9 - 14	8 - 14	6 - 10	17 - 23

Entering Water Temp °F	Water Flow gpm/ton	Heating -- No Hot Water Generation					
		Suction Pressure psig	Discharge Pressure psig	Superheat	Subcooling	Water Temp Drop °F	Air Temp Rise °F DB
30	1.5	73 - 85	270 - 305	8 - 14	3 - 10	6 - 10	15 - 21
	3.0	77 - 90	280 - 315	8 - 14	3 - 10	4 - 8	17 - 23
50	1.5	97 - 110	290 - 325	10 - 16	3 - 10	9 - 13	22 - 28
	3.0	102 - 115	300 - 335	10 - 16	3 - 10	7 - 11	24 - 30
70	1.5	130 - 145	320 - 355	13 - 19	3 - 10	10 - 14	30 - 36
	3.0	135 - 150	325 - 360	13 - 19	3 - 10	8 - 12	32 - 38
90	1.5	150 - 160	350 - 390	13 - 19	3 - 10	10 - 14	30 - 36
	3.0	155 - 165	365 - 405	13 - 19	3 - 10	8 - 12	32 - 38
110	1.5						
	3.0						

NOTE: Cooling performance based on entering air temperatures of 80° F DB, 67° F WB.
Heating performance based on entering air temperature of 70° F DB.

2/15/12

Pressure Drop

Single Speed Pressure Drop

Model	GPM	Pressure Drop (psi)				
		30°F	50°F	70°F	90°F	110°F
009	1.5	1.9	1.8	1.7	1.6	1.5
	2.0	3.5	3.4	3.2	3.1	3.0
	3.0	6.9	6.5	6.3	6.0	5.7
	4.0	12.0	11.4	11.0	10.8	10.5
012	1.5	0.3	0.3	0.3	0.3	0.3
	2.5	1.0	1.0	1.0	1.0	1.0
	3.5	1.7	1.7	1.7	1.6	1.6
	4.5	2.5	2.4	2.4	2.4	2.3
015	2.0	0.6	0.6	0.6	0.6	0.6
	3.0	1.6	1.6	1.6	1.6	1.6
	4.0	2.6	2.6	2.6	2.6	2.5
	5.0	3.7	3.7	3.6	3.6	3.5
018	3.0	1.6	1.6	1.5	1.5	1.4
	4.0	2.9	2.9	2.8	2.8	2.7
	5.0	4.2	4.2	4.1	4.0	3.9
	6.0	6.0	5.8	5.7	5.6	5.5
024	3.0	1.0	0.8	0.7	0.5	0.4
	4.0	1.1	1.1	0.9	0.8	0.6
	6.0	2.1	2.0	1.8	1.7	1.5
	8.0	4.1	4.0	3.8	3.7	3.5
030	4.0	1.3	1.2	1.2	1.1	1.0
	6.0	2.7	2.5	2.4	2.2	2.2
	8.0	4.5	4.2	3.9	3.7	3.4
	10.0	6.8	6.3	5.4	5.4	5.0
036	5.0	1.0	1.0	0.9	0.8	0.8
	7.0	2.1	1.9	1.8	1.7	1.6
	9.0	3.6	3.3	3.0	2.8	2.6
	12.0	6.3	5.9	5.5	5.1	4.8
042	5.0	0.8	0.7	0.7	0.7	0.6
	8.0	2.1	2.1	1.9	1.8	1.7
	11.0	4.2	4.1	3.8	3.5	3.3
	14.0	7.6	6.7	6.3	5.8	5.4
048	6.0	1.1	1.0	1.0	0.9	0.8
	9.0	2.3	2.1	2.0	1.9	1.7
	12.0	3.9	3.7	3.4	3.2	3.0
	16.0	6.7	6.3	5.9	5.5	5.1
060	9.0	2.4	2.2	2.1	2.0	1.8
	12.0	3.9	3.6	3.4	3.2	2.9
	15.0	5.7	5.3	5.0	4.7	4.3
	20.0	9.5	8.9	8.3	7.8	7.2
072	12.0	3.0	2.8	2.6	2.4	2.2
	15.0	4.4	4.0	3.8	3.5	3.3
	18.0	6.0	5.5	5.1	4.8	4.4
	24.0	9.7	9.1	8.5	7.9	7.3

5/7/24

Valve	GPM	Cv	Pressure Drop (psi)
1/2"	1.5	9.6	0.02
	2.0	9.7	0.04
	3.0	9.9	0.09
	4.0	10.1	0.16
1/2"	1.5	9.6	0.02
	2.5	9.8	0.06
	3.5	10.0	0.12
	4.5	10.2	0.19
3/4"	2.0	9.7	0.04
	3.0	9.9	0.09
	4.0	10.1	0.16
	5.0	10.4	0.23
3/4"	3.0	9.9	0.09
	4.0	10.1	0.16
	5.0	10.4	0.23
	6.0	10.6	0.32
3/4"	3.0	9.9	0.09
	4.5	10.2	0.19
	6.0	10.6	0.32
	8.0	11.0	0.53
3/4"	4.0	10.1	0.16
	6.0	10.6	0.32
	8.0	11.0	0.53
	10.0	11.5	0.76
1"	5.0	15.9	0.10
	7.0	16.6	0.23
	9.0	17.2	0.41
	12.0	17.9	0.61
1"	5.0	15.9	0.10
	8.0	16.6	0.23
	11.0	17.2	0.41
	14.0	17.9	0.61
1"	6.0	16.1	0.14
	9.0	16.8	0.29
	12.0	17.4	0.47
	16.0	18.3	0.76
1"	9.0	16.8	0.29
	12.0	17.4	0.47
	15.0	18.1	0.69
	20.0	19.2	1.09
1"	12.0	17.4	0.47
	15.0	18.1	0.69
	18.0	18.7	0.92
	24.0	20.1	1.43

3/16/12

Dual Capacity Pressure Drop

Model	GPM	Pressure Drop (psi)					Model	GPM	Pressure Drop (psi)				
		30°F	50°F	70°F	90°F	110°F			30°F	50°F	70°F	90°F	110°F
018 full load	3	1.8	1.7	1.6	1.5	1.4	042 full load	5	1.5	1.4	1.3	1.2	1.1
	4	3.3	3.1	2.9	2.7	2.5		8	3.5	3.3	3.1	2.9	2.7
	5	4.8	4.5	4.2	3.9	3.6		11	5.6	5.2	4.9	4.6	4.2
	6	6.0	5.8	5.5	5.3	5.2		14	7.5	7.1	6.7	6.3	5.7
018 part load	2	1.8	1.7	1.6	1.5	1.4	042 part load	4	0.9	0.9	0.8	0.7	0.7
	3	3.3	3.1	2.9	2.7	2.5		6	2.0	1.9	1.8	1.7	1.6
	4	4.8	4.5	4.2	3.9	3.6		8	3.2	3.0	2.8	2.6	2.4
	5	4.2	4.2	4.1	4.0	3.9		9	4.2	4.1	3.8	3.5	3.2
024 full load	4	1.4	1.3	1.2	1.1	1.0	048 full load	6	1.4	1.3	1.2	1.1	1.0
	6	3.2	3.0	2.8	2.6	2.4		9	2.7	2.6	2.4	2.3	2.1
	8	5.1	4.8	4.5	4.2	3.9		12	4.1	3.8	3.6	3.5	3.1
	10	7.0	6.6	6.2	5.8	5.3		15	5.3	4.9	4.5	4.3	4.1
024 part load	3	0.8	0.7	0.7	0.7	0.6	048 part load	5	1.1	1.1	0.9	0.8	0.7
	5	2.4	2.2	2.0	2.1	1.8		8	2.3	2.1	2.1	1.9	1.7
	7	4.0	3.7	3.3	3.2	3.0		11	3.5	3.3	3.1	2.9	2.7
	9	5.8	5.5	5.1	4.8	4.4		14	4.7	4.5	4.1	3.9	3.7
030 full load	4	1.3	1.2	1.2	1.1	1.0	060 full load	8	2.6	2.5	2.3	2.1	2.0
	6	2.6	2.5	2.3	2.1	2.0		12	4.8	4.5	4.2	3.9	3.6
	8	4.2	4.0	3.7	3.4	2.9		16	7.0	6.6	6.2	5.8	5.4
	10	6.8	6.3	5.4	5.4	5.0		20	9.2	8.5	8.0	7.7	7.2
030 part load	4	1.3	1.2	1.2	1.1	1.0	060 part load	6	1.8	1.7	1.6	1.5	1.4
	6	2.6	2.5	2.3	2.1	2.0		10	3.6	3.4	3.2	3.0	2.8
	7	3.4	3.2	3.0	2.8	2.6		14	5.6	5.2	4.9	4.6	4.2
	8	4.2	4.0	3.7	3.4	2.9		18	8.6	8.0	7.6	7.2	6.6
036 full load	5	1.2	1.2	1.1	1.0	1.0	072 full load	12	3.2	3.0	2.8	2.6	2.4
	7	2.7	3.6	2.4	2.2	2.1		15	4.5	4.2	4.0	3.7	3.4
	9	3.9	3.6	3.4	3.2	2.9		18	6.0	5.7	5.3	4.9	4.6
	11	5.2	4.9	4.7	4.5	4.2		21	7.8	7.3	6.8	6.4	5.9
036 part load	4	1.1	1.1	1.0	0.9	0.9	072 part load	10	2.3	2.1	2.0	1.9	1.7
	6	2.4	2.2	2.1	2.0	1.8		13	3.4	3.2	3.0	2.8	2.6
	8	3.7	3.5	3.2	3.0	2.8		16	4.9	4.6	4.3	4.0	3.7
	10	5.0	4.8	4.5	4.3	3.9		19	6.4	6.2	5.8	5.4	5.0

1/31/24

Aurora® Control System

Aurora® ‘Base’ Control

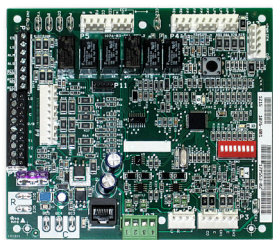

NOTE: Refer to the Aurora® Base Control Application and Troubleshooting Guide and the Instruction Guide: Aurora® Interface and Diagnostics (AID) Tool for additional information.

Control Features

Software ABC Standard Version 4.0

Single or Dual Capacity Compressors

Either single or dual capacity compressors can be operated.

Variable Speed ECM

Blower Motor Option (If Applicable)

A Variable Speed ECM blower motor can be driven directly using the onboard PWM output. Four blower speeds are available based upon the G, Y1, Y2, and W input signals to the board. The blower speeds can be changed either by the ECM manual configurations mode method or by using the Aurora® AID Tool directly. All four blower speeds can be set to the same speed if desired.

5-Speed ECM Blower Motor Option (If Applicable)

A 5-Speed ECM blower motor will be driven directly using the thermostat connections. Any of the G, Y1, or Y2/W signals can drive any of the 5 available pre-programmed blower speeds on the motor.

Other Control Features

- Random start at power up
- Anti-short cycle protection
- High and low pressure cutouts
- Loss of charge detection
- Water coil freeze detection
- Air coil freeze detection
- Over/under voltage protection
- Condensate overflow sensor
- Load shed
- Dehumidification (where applicable)
- Emergency shutdown
- Hot gas reheat operation (where applicable)
- Diagnostic LED
- Test mode push button switch
- Two auxiliary electric heat outputs
- Alarm output
- Accessory output with N.O. and N.C.
- Two Modbus communication Ports

Field Selectable Options via Hardware

DIP Switch (SW1) – Test/Configuration Button (See SW1 Operation Table)

Test Mode

The control is placed in the test mode by holding the push button switch SW1 for 2 - 5 seconds. In test mode most of the control timings will be shortened by a factor of sixteen (16). LED3 (green) will flash at 1 second on and 1 second off. Additionally, when entering test mode LED1 (red) will flash the last lockout one time. Test mode will automatically time out after 30 minutes. Test mode can be exited by pressing and holding the SW1 button for 2 to 5 seconds or by cycling the power. **NOTE:** Test mode will automatically be exited after 30 minutes.

Variable Speed ECM Configuration Mode (If Applicable)

The control is placed in the ECM configuration mode by holding the pushbutton switch SW1 for 5 to 10 seconds, the high, low, and “G” ECM speeds can be selected by following the LED display lights. LED2 (yellow) will fast flash when entering the ECM configuration. When setting “G” speed LED3 (green) will be continuously lit, for low speed LED1 (red) will be continuously lit, and for high speed both LED3 (green) and LED1 (red) will be continuously lit. During the ECM configuration mode LED2 (yellow) will flash each of the 12 possible blower speeds 3 times. When the desired speed is flashed press SW1, LED2 will fast flash until SW1 is released. “G” speed has now been selected. Next select low speed, and high speed blower selections following the same process above. After third selection has been made, the control will exit the ECM configuration mode. Aux fan speed will remain at default or current setting and requires the AID Tool for adjustment.

Reset Configuration Mode

The control is placed in reset configuration mode by holding the push button switch SW1 for 50 to 60 seconds. This will reset all configuration settings and the EEPROM back to the factory default settings. LED3 (green) will turn off when entering reset configuration mode. Once LED3 (green) turns off, release SW1 and the control will reset.

DIP Switch (SW2)

SW2-1 FP1 Selection – Low water coil temperature limit setting for freeze detection. On = 30°F; Off = 15°F.

SW2-2 FP2 Selection – On = 30°F; Off = N/A

SW2-3 RV – O/B - thermostat type. Heat pump thermostats with “O” output in cooling or “B” output in Heating can be selected. On = O; Off = B.

SW2-4 and 2-5 Access Relay Operation (P2)

Access Relay Operation	SW2-4	SW2-5
Cycle with Blower	ON	ON
Cycle with Compressor	OFF	OFF
Water Valve Slow Opening	ON	OFF
Cycle with Comm. T-stat Hum Cmd	OFF	ON

Aurora® Control System cont.

Cycle with Blower - The accessory relay will cycle with the blower output.

Cycle with Compressor - The accessory relay will cycle with the compressor output.

Water Valve Slow Opening - The accessory relay will cycle and delay both the blower and compressor output for 90 seconds.

- SW2-6** CC Operation – selection of single or dual capacity compressor. On = Single Stage; Off = Dual Capacity
- SW2-7** Lockout and Alarm Outputs (P2) – selection of a continuous or pulsed output for both the LO and ALM Outputs. On = Continuous; Off = Pulsed
- SW2-8** Future Use

Alarm Jumper Clip Selection

From the factory, ALM is connected to 24 VAC via JW2. By cutting JW2, ALM becomes a dry contact connected to ALG.

Variable Speed ECM Blower Speeds

The blower speeds can be changed either by using the ECM manual configurations mode method or by using the Aurora® AID Tool directly (see Instruction Guide: Aurora® Interface and Diagnostics (AID) Tool topic).

Field Selectable Options via Software

(Selectable via the Aurora® AID Tool)

ECM Blower Speeds

An ECM blower motor can be driven directly using the onboard PWM output. Four blower speeds are available, based upon the “G”, Y1 (low), Y2 (high), and Aux input signals to the board. The blower speeds can be changed either by the ECM manual configurations mode method (see ECM Configuration Mode topic) or by using the Aurora® AID Tool directly. All four blower speeds can be set to the same speed if desired. Aux blower speed will remain at default or current setting and requires the AID Tool for adjustment.

Safety Features

The following safety features are provided to protect the compressor, heat exchangers, wiring and other components from damage caused by operation outside of design conditions.

Fuse - a 3 amp automotive type plug-in fuse provides protection against short circuit or overload conditions.

Anti-Short Cycle Protection - 4 minute anti-short cycle protection for the compressor.

Random Start - 5 to 80 second random start upon power up.

Fault Retry - in the fault condition, the control will stage off the outputs and then “try again” to satisfy the thermostat Y input call. Once the thermostat input calls are satisfied, the control will continue on as if no fault occurred. If 3 consecutive faults occur without satisfying the thermostat Y input call, then the control will go to Lockout mode.

Lockout - when locked out, the blower will operate continuously in “G” speed, and PSC blower motor output will remain on. The Alarm output (ALM) and Lockout output (L) will be turned on. The fault type identification display LED1 (Red) shall flash the fault code. To reset lockout conditions with SW2-8 On, thermostat inputs “Y1”, “Y2”, and “W” must be removed for at least 3 seconds. To reset lockout conditions with SW2-8 Off, thermostat inputs “Y1”, “Y2”, “W”, and “DH” must be removed for at least 3 seconds. Lockout may also be reset by turning power off for at least 30 seconds or by enabling the emergency shutdown input for at least 3 seconds.

Lockout With Emergency Heat - if the control is locked out in the heating mode, and a Y2 or W input is received, the control will operate in the emergency heat mode while the compressor is locked out. The first emergency heat output will be energized 10 seconds after the W input is received, and the blower will shift to high speed. If the control remains locked out, and the W input is present, additional stage of emergency heat will stage on after 2 minutes. When the W input is removed, all of the emergency heat outputs will turn off, and the ECM blower will shift to “G” speed and PSC blower motor output will remain on.

High Pressure - fault is recognized when the Normally Closed High Pressure Switch, P4-9/10 opens, no matter how momentarily. The High Pressure Switch is electrically in series with the Compressor Contactor and serves as a hard-wired limit switch if an overpressure condition should occur.

Low Pressure - fault is recognized when the Normally Closed Low Pressure Switch, P4-7/8 is continuously open for 30 seconds. Closure of the LPS any time during the 30 second recognition time restarts the 30 second continuous open requirement. A continuously open LPS shall not be recognized during the 2 minute startup bypass time.

Loss of Charge - fault is recognized when the Normally Closed Low Pressure Switch, P4-7/8 is open prior to the compressor starting.

Condensate Overflow - fault is recognized when the impedance between this line and 24 VAC common or chassis ground drops below 100K ohms for 30 seconds continuously.

Freeze Detection (Coax) - set points shall be either 30°F or 15°F. When the thermistor temperature drops below the selected set point, the control shall begin counting down the 30 seconds delay. If the thermistor value rises above the selected set point, then the count should reset. The resistance value must remain below the selected set point for the entire length of the appropriate delay to be recognized as a fault. This fault will be ignored for the initial 2 minutes of the compressor run time.

Freeze Detection (Air Coil) - uses the FP2 input to protect against ice formation on the air coil. The FP2 input will operate exactly like FP1 except that the set point is 30 degrees and is not field adjustable.

Aurora® Control System cont.

Over/Under Voltage Shutdown - An over/under voltage condition exists when the control voltage is outside the range of 18 VAC to 30 VAC. If the over/under voltage shutdown lasts for 15 minutes, the lockout and alarm relay will be energized. Over/under voltage shutdown is self-resetting in that if the voltage comes back within range of 18 VAC to 30 VAC for at least 0.5 seconds, then normal operation is restored.

Operation Description

Power Up - The unit will not operate until all the inputs and safety controls are checked for normal conditions. The unit has a 5 to 80 second random start delay at power up. Then the compressor has a 4 minute anti-short cycle delay after the random start delay.

Standby In standby mode, Y1, Y2, W, DH, and G are not active. Input O may be active. The blower and compressor will be off.

Heating Operation

Single Compressor Heating, 2nd Stage (Y1, Y2)

The compressor will be staged to full capacity 20 seconds after Y2 input is received. The ECM blower will shift to high speed seconds after the Y2 input is received.

Dual Compressor Heating, 2nd Stage (Y1, Y2)

In dual compressor operation, two ABC boards used in 24 VAC operation, there will be a Y2 call to the Y1 input on the second ABC. The compressor will stage to full capacity 30 seconds after Y1 input is received to the second board.

Single Compressor Heating, 3rd Stage (Y1, Y2, W)

The hot water pump is de-energized and the first stage of electric heat is energized 10 seconds after the W command is received. If the demand continues the second stage of electric heat will be energized after 5 minutes.

Dual Compressor Heating, 3rd Stage (Y1, Y2, W) -

The first stage of electric heat is energized 10 seconds after the W command is received. If the demand continues the second stage of electric heat will be energized after 5 minutes

Emergency Heat (W) - The blower will be started on "G" speed, 10 seconds later the first stage of electric heat will be turned on. 5 seconds after the first stage of electric heat is energized the blower will shift to Aux speed. If the emergency heat demand is not satisfied after 2 minutes the second electric heat stage will be energized.

Blower (G) - The blower will start immediately upon receiving a thermostat G command. If there are no other commands from the thermostat the ECM will run on "G" speed until the G command is removed. Regardless of blower input (G) from the thermostat, the blower will remain on for 30 seconds at the end of each heating cycle.

Cooling Operation

In all cooling operations, the reversing valve directly tracks the O input. Thus, anytime the O input is present, the reversing valve will be energized.

Single Compressor Cooling, 2nd Stage (Y1, Y2, O)

The compressor will be staged to full capacity 20 seconds after Y2 input was received. The ECM blower will shift to high speed 15 seconds after the Y2 input was received.

Dual Compressor Cooling, 2nd Stage (Y1, Y2, O)

In dual compressor operation, two ABC boards used in 24 VAC operation, there will be a Y2 call to the Y1 input on the second ABC. The compressor will stage to full capacity 30 seconds after Y1 input is received to the second board.

Blower (G) - The blower will start immediately upon receiving a thermostat G command. If there are no other commands from the thermostat the ECM will run on "G" speed until the G command is removed. Regardless of blower input (G) from the thermostat, the blower will remain on for 30 seconds at the end of each heating, cooling, and emergency heat cycle.

Dehumidification (Y1, O, DH or Y1, Y2, O, DH) - When a DH command is received from the thermostat during a compressor call for cooling the ECM blower speed will be reduced by 15% to increase dehumidification.

Emergency Shutdown - Four (4) seconds after a valid ES input, P2-7 is present, all control outputs will be turned off and remain off until the emergency shutdown input is no longer present. The first time that the compressor is started after the control exits the emergency shutdown mode, there will be an anti-short cycle delay followed by a random start delay. Input must be tied to common to activate.

Continuous Blower Operation - The blower output will be energized any time the control has a G input present, unless the control has an emergency shutdown input present. The blower output will be turned off when G input is removed.

Load Shed - The LS input disables all outputs with the exception of the blower output. When the LS input has been cleared, the anti-short cycle timer and random start timer will be initiated. Input must be tied to common to activate.

Aurora® Control System cont.

Aurora® ‘Base’ Control LED Displays

These three LEDs display the status, configuration, and fault codes for the control. These can also be read in plain English via the Aurora® AID Tool.

Status LED (LED3, Green)

Description of Operation	Fault LED, Green
Normal Mode	ON
Control is Non-functional	OFF
Test Mode	Slow Flash
Lockout Active	Fast Flash
Dehumidification Mode	Flash Code 2
(Future Use)	Flash Code 3
(Future Use)	Flash Code 4
Load Shed	Flash Code 5
ESD	Flash Code 6
(Future Use)	Flash Code 7

Configuration LED (LED2, Yellow)

Description of Operation	Configuration LED, Yellow
No Software Overwritten	Flashing ECM Setting
DIP Switch was Overwritten	Slow Flash
ECM Configuration Mode	Fast Flash

Fault LED (LED1, Red)

Red Fault LED	LED Flash Code*	Lockout	Reset/Remove
Normal - No Faults	OFF	-	
Fault - Input	1	No	Auto
Fault - High Pressure	2	Yes	Hard or Soft
Fault - Low Pressure	3	Yes	Hard or Soft
Fault - Freeze Detection FP2	4	Yes	Hard or Soft
Fault - Freeze Detection FP1	5	Yes	Hard or Soft
Fault - Condensate Overflow	7	Yes	Hard or Soft
Fault - Over/Under Voltage	8	No	Auto
Fault - FP1 & FP2 Sensor Error	11	Yes	Hard or Soft

NOTE: All codes >11 use long flash for tens digit and short flash for the ones digit. 20, 30, 40, 50, etc. are skipped.

Aurora® Interface and Diagnostics (AID) Tool

The Aurora® Interface and Diagnostics (AID) Tool is a device that is a member of the Aurora® network. The AID Tool is used to troubleshoot equipment which uses the Aurora® control via Modbus RTU communication. The AID Tool provides diagnostics, fault management, ECM setup, and system configuration capabilities to the Aurora® family of controls. An AID Tool is recommended, although not required, for ECM airflow settings. The AID Tool simply plugs into the exterior of the cabinet in the AID Tool port.



ABC Control Board Layout

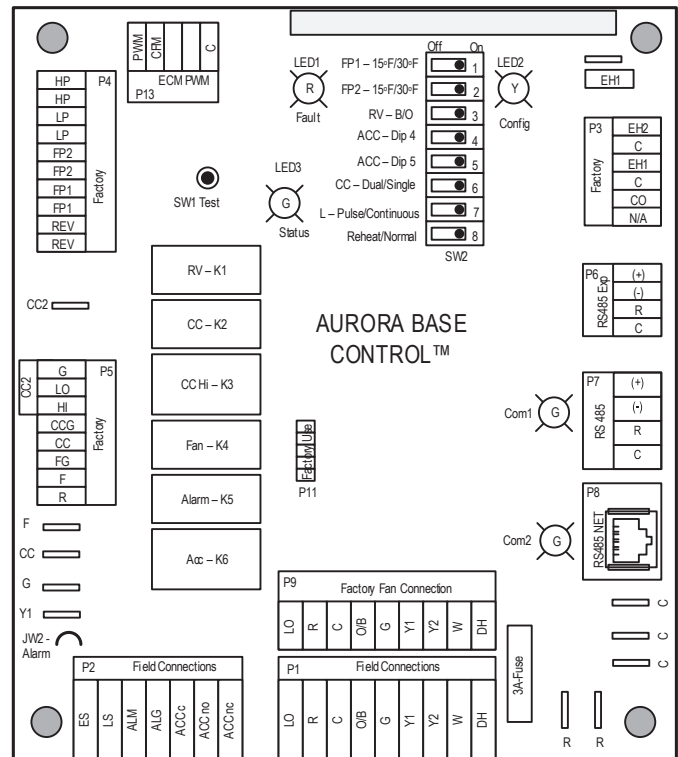

Aurora® Control System cont.

Aurora® ‘Advanced’ Control Features

The Aurora® ‘Advanced’ Control system expands on the capability of the Aurora® ‘Base’ Control (ABC) by adding the Aurora® Expansion Board (AXB).

All of the preceding features of the Aurora® ‘Base’ Control are included.

The following control description is of the additional features and capability of the Aurora® advanced control.

It is highly recommended the installing/servicing contractor obtain an Aurora® Interface and Diagnostic Tool (AID) and specialized training before attempting to install or service an Aurora® ‘Advanced’ control system.

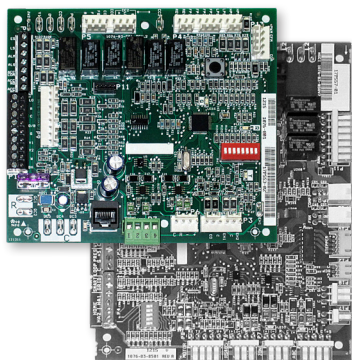

The additional AXB features include the following:

AXB DIP Switch

DIP 1 - ID: This is the AXB ModBus ID and should always read On.

DIP 2 & 3 - Future Use

DIP 4 & 5 - Accessory Relay2: A second, DIP configurable, accessory relay is provided that can be cycled with the compressor 1 or 2, blower, or the Dehumidifier (DH) input. This is to complement the Accessory 1 Relay on the ABC board.

Position	DIP 4	DIP 5	Description
1	ON	ON	Cycles with Fan or ECM (or G)
2	OFF	ON	Cycles with CC1 first stage of compressor or compressor spd 6
3	ON	OFF	Cycles with CC2 second stage of compressor or compressor spd 7-12
4	OFF	OFF	Cycles with DH input from ABC board

Advanced Hot Water Generator Control (Domestic Hot Water Option)

In lieu of the ‘Base Hot Water Generator Control’, the Advanced features an AID Tool selectable temperature limit and microprocessor control of the process. This will maximize hot water generation and prevent undesirable energy use. An alert will occur when the hot water input temperature is at or above setpoint (100°F - 140°F) for 30 continuous seconds (130°F is the default setting). This alert will appear as an E15 on the AID Tool and the hot water pump de-energizes. Hot water pump operations resume on the next compressor cycle

or after 15 minutes of continuous compressor operation during the current thermostat demand cycle. Since compressor hot gas temperature is dependent on loop temperature in cooling mode, loop temperatures may be too low to allow proper heating of water. The control will monitor water and refrigerant temperatures to determine if conditions are satisfactory for heating water. LED1 (red LED) will flash code 15 when the DHW limit is reached and when conditions are not favorable for water heating. Error code 15 will also be displayed on the AID Tool in the fault screen. This flash code is a noncritical alert and does not necessarily indicate a problem.

Compressor Monitoring

The AXB includes two current transducers to monitor the compressor current and starting characteristics. Open circuits or welded contactor faults will be detected. A fault will produce an E10 code.

IntelliZone2® Zoning Compatibility (Optional IntelliZone2® Zoning)

A dedicated input to connect and communicate with the IntelliZone2® (IZ2) zoning system is provided on P7. This is a dedicated communication port using a proprietary ModBus protocol. An AXB can be added to other selected ABC-only systems as well. Then an advanced communicating IntelliZone2® zoning system can be added to ABC-only systems. Consult the IntelliZone2® literature for more information.

Variable Speed Pump

This input and output are provided to drive and monitor a variable speed pump. The VS pump output is a PWM signal to drive the variable speed pump. The minimum and maximum level are set using the AID Tool. 75% and 100% are the default settings respectively. The VS data input allows a separate PWM signal to return from the pump giving fault and performance information. Fault received from the variable speed pump will be displayed as E16.

Modulating Water Valve

This output is provided to drive a modulating water valve. Through advanced design the 0-10VDC valve can be driven directly from the VS pump output. The minimum and maximum level are set in the same way as the VS pump using the AID Tool. 75% and 100% are the default settings respectively.

Loop Pump Linking

This input and output are provided so that two units can be linked together with a common flow center. When either unit has a call for loop pump, both unit’s loop pump relays and variable speed pumps are energized. The flow center then can simply be wired to either unit. The output from one unit should be routed to the input of the other. If daisy chained up to 16 heat pumps can be wired and linked together in this fashion.

Aurora® Control System cont.

Advanced Communication Ports

Communication ports P6 and P8 will provide future expansion via dedicated protocols. These are for future use.

Smart Grid-On Peak (SG) Input

The 'On Peak' input was designed to allow utilities to utilize simple radio controlled switches to control the On Electric Peak behavior of the manufacturers Geothermal Heat Pumps. With a closed contact signal, this input will limit the operation and thus the power consumption of the unit by one of the below selections. The AID Tool will allow configuration of this input for the action of:

- No Action
- Disable compressor operation until removed
- Go to On Peak thermostat settings until removed [Requires Com T-Stat] (Future Release)
- Compressor limited to 50% or low cap until removed [dual capacity or variable speed only] (Future Release)
- Disable compressor operation for 1/2 hr (can be removed immediately) (Future Release)

Then Flash Code 7 on the Green LED for the 'On Peak' mode. And On Peak will display on communicating thermostats.

Home Automation 1 and 2 Inputs

The Home automation inputs are simple closed contact inputs that will trigger an AID Tool and thermostat alert for the homeowner. These would require optional sensors and or equipment for connection to the AXB board. With two inputs two different sensors can be selected. The selected text will then be displayed on the AID Tool and communicating thermostats. These events will NOT alter functionality or operation of the heat pump/accessories and is for homeowner/service notification only.

Home Automation 1 - E23 HA1

With a closed dry contact signal, this input will cause an alarm and Alert Code 23 to indicate on the stat or flash on ABC. The AID Tool will allow configuration of this input between the following selections:

- No Action
- Home Automation Fault [no lockout info only]
 - Output from home automation system
- Security Alarm [no lockout info only]
 - Output from home security
- Sump Alarm Fault [no lockout info only]
 - Switch output from sump sensor
- Smoke/CO Alarm Fault [no lockout info only]
 - Switch output from Smoke/CO sensor
- Dirty Filter Alarm [no lockout info only]
 - Output from dirty filter sensor

Home Automation 2 - E24 HA2

With a closed dry contact signal, this input will cause an alarm and Alert Code 24 to indicate on the stat or flash on ABC. The AID Tool will allow configuration of this input between the following selections:

- No Action
- Home Automation Fault [no lockout info only]
 - Output from home automation system
- Security Alarm [no lockout info only]
 - Output from home security
- Sump Alarm Fault [no lockout info only]
 - Switch output from sump sensor
- Smoke/CO Alarm Fault [no lockout info only]
 - Switch output from Smoke/CO sensor
- Dirty Filter Alarm [no lockout info only]
 - Output from dirty filter sensor

Monitoring Sensor Kits

Energy Monitoring

(Standard Sensor Kit on 'Advanced' models)

The Energy Monitoring Kit includes two current transducers (blower and electric heat) added to the existing two compressor sensors so that the complete power usage of the heat pump can be measured. The AID Tool provides configuration detail for the type of blower motor and a line voltage calibration procedure to improve the accuracy. This information can be displayed on the AID Tool or selected communicating thermostats. The TPCM32U03/04 will display instantaneous energy use while the color touchscreen TPCC32U will in addition display a 13 month history in graph form.

Refrigerant Monitoring (optional sensor kit)

The optional Refrigerant Monitoring Kit includes two pressure transducers, and three temperature sensors, heating liquid line, suction temperature and existing cooling liquid line (FP1). These sensors allow the measurement of discharge and suction pressures, suction and liquid line temperatures as well as superheat and subcooling. This information will only be displayed on the AID Tool.

Performance Monitoring (optional sensor kit)

The optional Performance Monitoring Kit includes three temperature sensors, entering and leaving water, leaving air temperature and a water flow rate sensor. With this kit heat of extraction and rejection will be calculated. This requires configuration using the AID Tool for selection of water or antifreeze.

Aurora® Control System cont.

Special Modes and Applications

5-Speed ECM Blower Motor

Normally the 5-Speed ECM motor can be driven off of thermostat signals and the ABC connector P9. Communicating thermostats, however present a special problem in this application since they operate without 24 VAC thermostat signals. The ABC board is wired to operate these systems from the alternate relay output signals CC1, CC2, Fan, and EH1 and should be wired for this.

Communicating Digital Thermostats

The Aurora® controls system also features either mono-chromatic or color touch screen graphic display thermostats for user interface. These displays not only feature easy to use graphical interface but display alerts and faults in plain English. Many of the features discussed here may not be applicable without these thermostats.

Dehumidification - Passive

In passive dehumidification mode, the airflow is reduced by 15% from the heating airflow setting. If cooling airflow is set to +5, -5 or -10% of heating airflow it will automatically be set to -15% of heating airflow whenever the dehumidification call is present in the communicating stat or from the thermostat input DH. If the airflow for cooling is already set to -15% no airflow change will be noticed from normal cooling. Dehumidification mode will be shown on the ABC and the communicating thermostats.

Aurora® ‘Advanced’ Control LED Displays

These three LEDs display the status, configuration, and fault codes for the control. These can also be read in plain English via the Aurora® AID Tool.

Status LED (LED3, Green)

Description of Operation	Fault LED, Green
Normal Mode	ON
Control is Non-functional	OFF
Test Mode	Slow Flash
Lockout Active	Fast Flash
Dehumidification Mode	Flash Code 2
Load Shed	Flash Code 5
Emergency Shutdown	Flash Code 6
On Peak Mode	Flash Code 7
(Future Use)	Flash Code 8
(Future Use)	Flach Code 9

Configuration LED (LED2, Yellow)

Description of Operation	Configuration LED, Yellow
No Software Overwritten	ECM Setting
DIP Switch Overwritten	Slow Flash
ECM Configuration Mode	Fast Flash
Reset Configuration Mode	OFF

Fault LED (LED1, Red)

Red Fault LED	LED Flash Code *	Lockout	Reset/Remove	Fault Condition Summary	
Normal - No Faults	Off	-			
ABC Basic Faults	Fault-Input	1	No	Auto	Tstat input error. Autoreset upon condition removal.
	Fault-High Pressure	2	Yes	Hard or Soft	HP switch has tripped (>600 psi)
	Fault-Low Pressure	3	Yes	Hard or Soft	Low Pressure Switch has tripped (<40 psi for 30 continuous sec.)
	Fault-Freeze Detection FP2	4	Yes	Hard or Soft	Freeze protection sensor has tripped (<15 or 30 degF for 30 continuous sec.)
	Fault-Freeze Detection FP1	5	Yes	Hard or Soft	Freeze protection sensor has tripped (<15 or 30 degF for 30 continuous sec.)
	Fault-Condensate Overflow	7	Yes	Hard or Soft	Condensate switch has shown continuity for 30 continuous sec.
	Fault-Over/Under Voltage	8	No	Auto	Instantaneous voltage is out of range. **Controls shut down until resolved.
	Fault-FP1 Snsr Error	11	Yes	Hard or Soft	If FP1 Sensor Error
ABC & AXB Advanced Faults	Fault-Compressor Monitor	10	Yes	Hard or Soft	Open Crkt, Run, Start or welded cont
	Non-CriticAXBSnsrErr	13	No	Auto	Any Other Sensor Error
	CriticAXBSnsrErr	14	Yes	Hard or Soft	Sensor Error for EEV or HW
	Alert-HotWtr	15	No	Auto	HW over limit or logic lockout. HW pump deactivated.
	Fault-VarSpdPump	16	No	Auto	Alert is read from PWM feedback.
	Not Used	17	No	Auto	I22 Com Fault. Autoreset upon condition removal.
	Non-CritComErr	18	No	Auto	Any non-critical com error
	Fault-CritComErr	19	No	Auto	Any critical com error. Auto reset upon condition removal
	Alarm - Low Loop Pressure	21	No	Auto	Loop pressure is below 3 psi for more than 3 minutes
	Alarm - Home Automation 1	23	No	Auto	Closed contact input is present on Dig 2 input - Text is configurable
Alarm - Home Automation 2	24	No	Auto	Closed contact input is present on Dig 3 input - Text is configurable	

NOTES:

*All codes >11 use long flash for tens digit and short flash for the ones digit. 20, 30, 40, 50 etc. are skipped!
Alert' is a noncritical sensor or function that has failed. Normal operation of the heat pump is maintained but service is desired at some point.

Controls - UPC2 DDC Control (optional)

Note: Not all factory installed options are available, please refer to WeDoGeo® to see available options.



Aurora® UPC2 Controller
(Optional Accessory for certain models)

The Aurora® Unitary Protocol Converter (UPC2) is designed to add-on to any Aurora® based heat pump control. The Aurora® Unitary Protocol Converter (UPC2) is designed to allow water source heat pumps to be integrated into Building Automation Systems (BAS) with ease. The Aurora® UPC2 is an integrated solution and communicates directly with the Aurora® Heat Pump Controls and allows access/control of a variety of internal Aurora® heat pump operations such as sensors, relay operation, faults and other information. In turn, the UPC2 then converts internal Aurora® Modbus protocol to BACnet MS/TP or BACnet IP and communicates to the BAS system. This provides the great benefit of complete control integration and a myriad of information available to the BAS from the heat pump control. Plus, it also allows individual unit configuration such as ECM fan speeds or freeze protection setting directly over the BAS without the need for access to the actual heat pump.

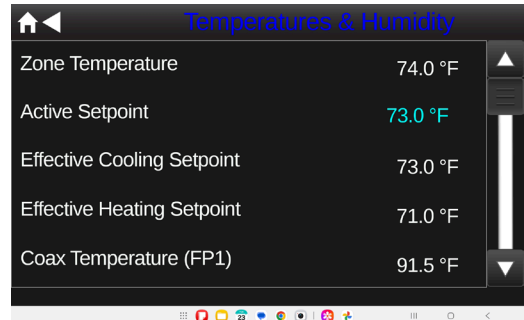

ZS Series Sensors
(Optional Accessory for certain models)

The Aurora® UPC2 is implemented with the Aurora® Base Controller (ABC) heat pump control into our latest water source heat pumps. This will allow for a BAS to integrate and communicate with the heat pump. The Aurora® UPC2 has the ability to communicate BACnet MS/TP or BACnet IP. All zone temperatures and zone sensors are connected to the UPC2 on an Rnet bus, simplifying hook up at the unit. Rnet sensors can include a combination of zone temperature and humidity, CO2, and VOC sensors.

There are an extensive number of points that the UPC2 has available over the network for integration into the BAS. Control programmers need to carefully determine which points they want to add to the BAS database. A list of the BACnet points are available along with their individual point descriptions by contacting the Commercial Solutions Group at 1-877-677-4420.

Controls - UPC2 DDC Control (optional)

Note: NOT all factory installed options are available, please refer to WeDoGeo® to see available options.

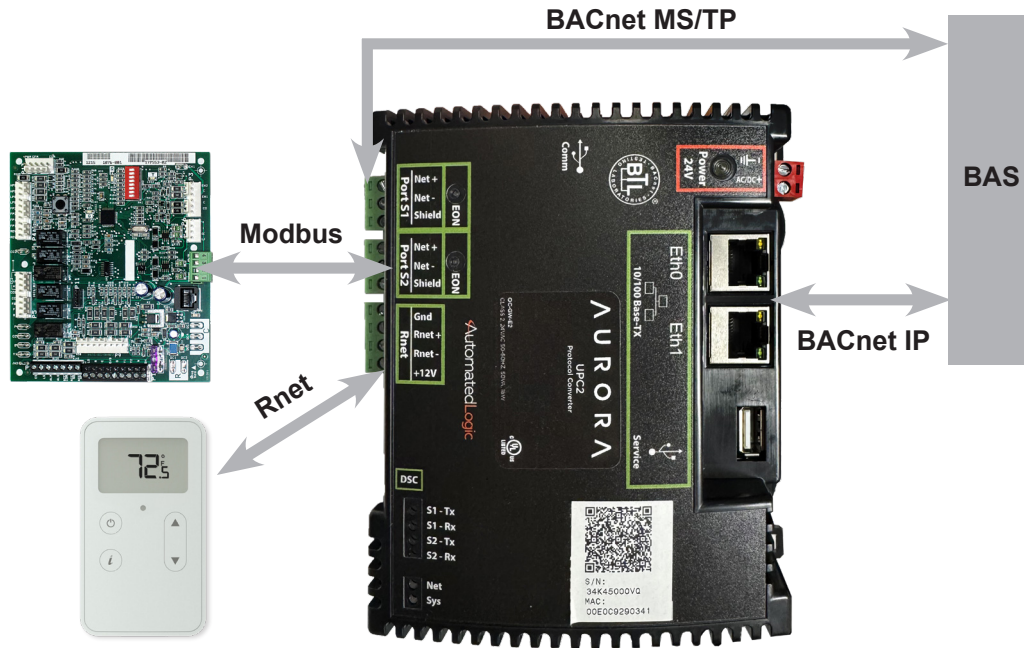

Aurora® UPC2 Features (Optional Accessory for certain models)

- Serves as a BACnet Broadcast Management Device (BBMD) for a BACnet/IP on each of the BACnet/IP networks
- Supports Foreign Device Registration (FDR)
- Supports DHCP IP addressing
- Has built in network diagnostic capture functionality for troubleshooting

Physical Ports

- **Eth0, Eth1**
 - 10/100 Mbps Ethernet
 - BACnet IP, BACnet IPv6, BACnet/Ethernet, BACnet SC
- **S1**
 - Aurora® Modbus RTU Port (Connects to ABC P8 with RJ45)
- **S2**
 - BACnet MS/TP
- **Service Port**
 - USB
 - BACnet/IP Service Port

Specifications

- **Power**
 - 24VAC +/-10%, 50-60 Hz
 - 24VDC +/-10%
- **Eth0, Eth1**
 - 10/100 BaseT, full duplex, Ethernet ports with built-in fail safe.
 - Supports direct connection or daisy chain topology natively using BACnet/IP and/or BACnet Ethernet communication.
 - Under normal operation, network traffic not destined for this controller is repeated to the other Ethernet port.
- **Port S1**
 - Used for internal heat pump communication on the Aurora® Modbus network.

- **Port S2**
 - For communication with BACnet MS/TP network at 9600 to 115200 bps.
- **Rnet Port**
 - Supports up to 15 ZS sensors and one Equipment Touch.
 - Supplies 12VDC/260 mA power to the Rnet across its rated temperature range.
- **Service Port**
 - USB 2.0 host port for setting up the device and troubleshooting through a local connection to a computer.
- **Real-time Clock**
 - Real-time clock keeps track of time in the event of a power failure for up to 3 days.
- **Environmental operating range**
 - -40 to 150°F (-40 to 70°C), 10-95% relative humidity, non-condensing
- **Physical**
 - Fire-retardant plastic ABS, UL94-5VA
- **BACnet Support**
 - Conforms to the BACnet Building Controller (B-BC), BACnet Router (B-RTR), BACnet Gateway (B-GW), and BACnet Broadcast Management Device (B-BBMD) Standard Device Profiles as defined in ANSI/ASHRAE Standard 135-2016 (BACnet) Annex L, Protocol Revision 19.
- **Compliance**
 - United States of America
 - FCC compliant to Title CFR47, Part 15, Subpart B, Class A
 - UL Listed, File E143900; CCN PAZX, UL916, Energy Management Equipment
 - Canada
 - UL Listed File E143900, CCN PAZX7, CAN/CSA C22.2 No. 205 Signal Equip.,
 - Industry Canada Compliant, ICES-003, Class A

Controls - UPC2 DDC Control (optional)

Note: Not all factory installed options are available, please refer to WeDoGeo® to see available options.

Aurora® UPC2 Optional Features (Optional Accessory for certain models)

- AID Tool for Aurora® ABC configuration and troubleshooting.
- Aurora® Advanced Control adds the Aurora® AXB expansion board and provides added I/O and standard features
- Optional Sensor Kits (requires Aurora® Advanced Control with AXB - Future Availability on Select Models/Configurations)

- **Refrigeration Monitoring** - provides Suction and discharge pressure, Suction, liquid line temps and superheat and subcooling.
- **Performance Monitoring** - provides entering and leaving loop water temperatures, loop flow rate as well as heat of extraction or rejection rate into the loop.
- **Energy Monitoring** - provides real-time power measurement (Watt) of compressor, fan, auxiliary heat and zone pump.

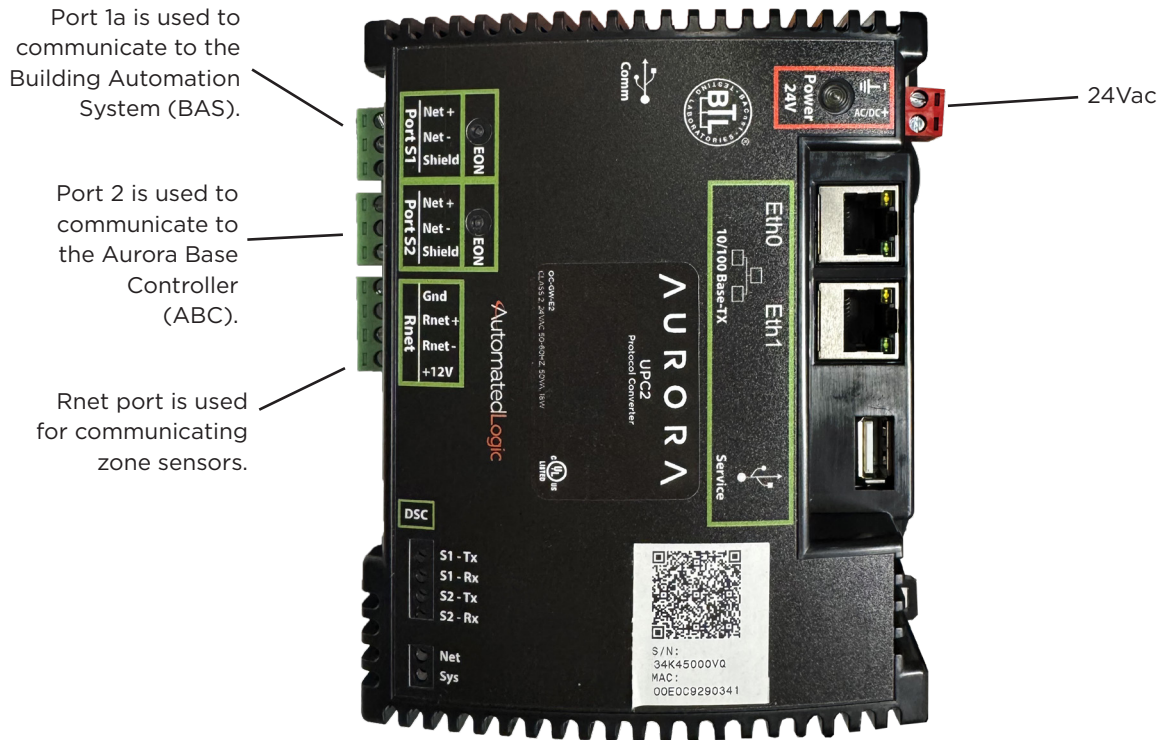

Aurora® UPC2 Smart Tablet Option (Optional Accessory - available only on certain models)

A smart tablet option is also available. Purchase a smart tablet accessory cable from manufacturer and download the OEMCtrl App and connect to the unit either at the unit itself or via the zone sensor. This means connecting to the unit to adjust fan speeds, check on fault etc. as easily as walking up to the zone sensor without the need for accessing ceiling tiles or a stepladder.



Controls - UPC2 DDC Control (optional)

Note: Not all factory installed options are available, please refer to WeDoGeo® to see available options.

- Leaving Air Temperature (LAT) Sensor** - This 10 kOhm NTC sensor is factory installed on all UPC2 equipped heat pumps. It typically is attached to wiring inside the blower cabinet on the suction side of the blower. This sensor is attached on ABC FP2 pins available as LAT AU-30.
- Compressor Proving Sensors** - This optional factory installed current sensor is connected to confirm compressor operation via the power wires. The sensor is attached at ABC Y1 and available at point BV-65.
- Valve End Switch** - This optional input is setup for a field installed flow valve end switch. This end switch input is attached at ABC Y2 and available at point BV-67.
- Fan Proving Sensors** - This optional factory installed current sensor is connected to confirm fan operation via the power wires. The sensor is attached at ABC G and available at point BV-33.
- Occupancy Sensor** - This standard feature includes a field installed and wired room sensor with occupancy sensor typically found in DDC systems. The RNet room sensors can be found thru your commercial representative. The occupancy Sensors are attached at ABC O and can be found at point BV-49.
- Dirty Filter Switch** - This optional field installed switch is connected to confirm dirty filter operation. The dirty filter switch can be found thru your commercial representative. The sensor is attached at ABC W and available at point BV-63.
- Fault, Configuration, and Status Codes** - The codes can be visible to the BAS if desired.

Aurora® Base Fault Codes (ABC Only)

Fault LED (LED1, Red)

	Red Fault LED	LED Flash Code*	Lockout	Reset/Remove
ABC Basic Faults	Normal - No Faults	OFF	-	
	Fault - Input	1	No	Auto
	Fault - High Pressure	2	Yes	Hard or Soft
	Fault - Low Pressure	3	Yes	Hard or Soft
	Fault - Freeze Detection FP2	4	Yes	Hard or Soft
	Fault - Freeze Detection FP1	5	Yes	Hard or Soft
	Fault - Condensate Overflow	7	Yes	Hard or Soft
	Fault - Over/Under Voltage	8	No	Auto
	Fault - FP1 & FP2 Sensor Error	11	Yes	Hard or Soft

NOTE: All codes >11 use long flash for tens digit and short flash for the ones digit. 20, 30, 40, 50, etc. are skipped.

Aurora® Advanced Fault Codes (ABC + AXB Expansion Board)

Fault LED (LED1, Red)

	Red Fault LED	LED Flash Code *	Lockout	Reset/Remove	Fault Condition Summary
ABC Basic Faults	Normal - No Faults	Off	-		
	Fault-Input	1	No	Auto	Tstat input error. Autoreset upon condition removal.
	Fault-High Pressure	2	Yes	Hard or Soft	HP switch has tripped (>600 psi)
	Fault-Low Pressure	3	Yes	Hard or Soft	Low Pressure Switch has tripped (<40 psi for 30 continuous sec.)
	Fault-Freeze Detection FP2	4	Yes	Hard or Soft	Freeze protection sensor has tripped (<15 or 30 degF for 30 continuous sec.)
	Fault-Freeze Detection FP1	5	Yes	Hard or Soft	Freeze protection sensor has tripped (<15 or 30 degF for 30 continuous sec.)
	Fault-Condensate Overflow	7	Yes	Hard or Soft	Condensate switch has shown continuity for 30 continuous sec.
	Fault-Over/Under Voltage	8	No	Auto	Instantaneous voltage is out of range. **Controls shut down until resolved.
ABC & AXB Advanced Faults	Fault-FP1 & 2 Snsr Error	11	Yes	Hard or Soft	If FP1 or 2 Sensor Error
	Fault-Compressor Monitor	10	Yes	Hard or Soft	Open Crkt, Run, Start or welded cont
	Non-CriticAXBSnsrErr	13	No	Auto	Any Other Sensor Error
	CriticAXBSnsrErr	14	Yes	Hard or Soft	Sensor Error for EEV or HW
	Alert-HotWtr	15	No	Auto	HW over limit or logic lockout. HW pump deactivated.
	Fault-VarSpdPump	16	No	Auto	Alert is read from PWM feedback.
	Not Used	17	No	Auto	I22 Com Fault. Autoreset upon condition removal.
	Non-CritComErr	18	No	Auto	Any non-critical com error
	Fault-CritComErr	19	No	Auto	Any critical com error. Auto reset upon condition removal
	Alarm - Low Loop Pressure	21	No	Auto	Loop pressure is below 3 psi for more than 3 minutes
	Alarm - Home Automation 1	23	No	Auto	Closed contact input is present on Dig 2 input - Text is configurable
	Alarm - Home Automation 2	24	No	Auto	Closed contact input is present on Dig 3 input - Text is configurable

NOTES:

*All codes >11 use long flash for tens digit and short flash for the ones digit. 20, 30, 40, 50 etc. are skipped!

Alert' is a noncritical sensor or function that has failed. Normal operation of the heat pump is maintained but service is desired at some point.

Controls - UPC2 DDC Control (optional)

Note: Not all factory installed options are available, please refer to WeDoGeo® to see available options.

Aurora® Base or Advanced Control Configuration and Status Codes

Status LED (LED3, Green)

Description of Operation	Fault LED, Green
Normal Mode	ON
Control is Non-functional	OFF
Test Mode	Slow Flash
Lockout Active	Fast Flash
Dehumidification Mode	Flash Code 2
Load Shed	Flash Code 5
Emergency Shutdown	Flash Code 6
On Peak Mode	Flash Code 7
(Future Use)	Flash Code 8
(Future Use)	Flash Code 9

Configuration LED (LED2, Yellow)

Description of Operation	Configuration LED, Yellow
No Software Overwritten	ECM Setting
DIP Switch Overwritten	Slow Flash
ECM Configuration Mode	Fast Flash
Reset Configuration Mode	OFF

- 1. Alarm Relay** - The Alarm relay (ALM) is factory connected to 24 VAC via jumper JW2. By cutting JW2, ABC ALM becomes a dry contact connected to ABC ALG. The Relay is field switchable between Factory setting as an Alarm output or available for other uses.
- 2. Accessory Relay1** - A configurable, accessory relay on the ABC is provided that can be cycled with the compressor, blower, or the Dehumidifier (DH) input. A third (factory) setting cycles the relay with the compressor but delays the compressor and blower output for 90 sec. Source pump or slow opening solenoid valves in well systems or variable speed primary pumping systems would be a prime use of this feature.

Access Relay Operation	SW2-4	SW2-5
Cycle with Blower	ON	ON
Cycle with Compressor	OFF	OFF
Water Valve Slow Opening	ON	OFF
Cycle with Comm. T-stat Hum Cmd	OFF	ON

- 3. Electric Heat EH1** - A digital 24VDC output is provided for electric heat powering. UPC2's Default programming has EH1 set for AUX/ELEC Heat operation and will be controlled using the UPC2's internal P.I.D. logic. However it can be changed by the BAS to be network controlled.
- 4. Electric Heat EH2** - A digital VDC output is provided for field options converted from the original EH2 output. Default UPC2 program has the EH2 output set for Network Control but can be changed by the BAS to be controlled by the UPC2's internal P.I.D. logic.

Controls - UPC2 DDC Control (optional)

Note: Not all factory installed options are available, please refer to WeDoGeo® to see available options.

Aurora® Advanced Control Configuration and Options (Future Availability on Select Models/Configurations)

- 1. Accessory Relay2** - A second, configurable, accessory relay on the AXB is provided that can be cycled with the compressor 1 or 2, blower, or the Dehumidifier (DH) input. This is to complement the Accessory 1 Relay on the ABC board.

Position	DIP 4	DIP 5	Description
1	ON	ON	Cycles with Fan or ECM (or G)
2	OFF	ON	Cycles with CC1 first stage of compressor or compressor spd 1-12
3	ON	OFF	Cycles with CC2 second stage of compressor or compressor spd 7-12
4	OFF	OFF	Cycles with DH input from ABC board

- 2. Analog Out** - A standard 0-10VDC analog output is provided. This output can be used to drive modulating dampers etc.
- 3. Variable Speed Pump or Modulating Water Valve (If applicable)** - This input and output are provided to drive and monitor a variable speed pump. The VS pump output is a PWM signal to drive the variable speed pump. The minimum and maximum level are set using the AID Tool. 75% and 100% are the default settings respectively. The VS data input allows a separate PWM signal to return from the pump giving fault and performance information. Fault received from the variable speed pump will be displayed as E16. **Modulating Water Valve** - This Variable speed PWM output is provided to optionally drive a modulating water valve. Through advanced design a 0-10VDC valve can be driven directly from the VS pump output. The minimum and maximum level are set in the same way as the VS pump using the AID Tool. 75% and 100% are the default settings respectively.
- 4. Loop Pump Linking (If applicable)** - This input and output are provided so that two units can be linked together with a common flow center. When either unit has a call for loop pump, both unit's loop pump relays and variable speed pumps are energized. The flow center then can simply be wired to either unit. The output from one unit should be routed to the input of the other. If daisy chained up to 16 heat pumps can be wired and linked together in this fashion.

Controls - UPC2 DDC Control (optional)

Note: Not all factory installed options are available, please refer to WeDoGeo® to see available options.

Aurora® Advanced Control Optional Sensor Kits (Availability on Select Models/Configurations)

1. **Energy Monitoring (Standard Sensor Kit on 'Advanced' models)** - The Energy Monitoring Kit includes two current transducers (blower and electric heat) added to the existing two compressor sensors so that the complete power usage of the heat pump can be measured. The BACview Tool provides configuration detail for the type of blower motor and a line voltage calibration procedure to improve the accuracy. This real time power usage information can be displayed on the AID Tool and is available thru network points when using BACnet.
 - Compressor Current 1
 - Compressor Current 2
 - Fan Current
 - Aux Heat Current
 - Pump Selection
 - Voltage
 - Compressor Watts
 - Fan Watts
 - Aux Heat Watts
 - Pump Watts (VS Only)

2. **Refrigerant Monitoring (optional sensor kit)** - The optional Refrigerant Monitoring Kit includes two pressure transducers, and three temperature sensors, heating liquid line, suction temperature and existing cooling liquid line (FP1). These sensors allow the measurement of discharge and suction pressures, suction and liquid line temperatures as well as superheat and subcooling. This information can be displayed on the BACview Tool, or the network when using BACnet.
 - Htg Liquid Line
 - Clg Liquid Line
 - Discharge pressure
 - Suction Pressure
 - Discharge Saturated Temp
 - Suction Saturated Temperature
 - Superheat
 - SubCooling

3. **Performance Monitoring (optional sensor kit)** - The optional Performance Monitoring Kit includes: three temperature sensors, entering and leaving water, leaving air temperature and a water flow rate sensor. With this kit, heat of extraction and rejection will be calculated. This requires configuration using the BACview Tool for selection of water or antifreeze.
 - Leaving Air Temperature (supply)
 - Alt Leaving Air Temperature (Supply)
 - Entering Water Temperature
 - Leaving Water Temperature
 - Water Flow Meter
 - Entering Air Temperature (from zone sensor)
 - Brine Selection (water/antifreeze)
 - Heat of Extraction/Rejection

Controls - UPC2 DDC Control (optional)

Note: Not all factory installed options are available, please refer to WeDoGeo® to see available options.

ZS Series RNet Sensor Overview

The ZS Series line of intelligent zone sensors provides the function and flexibility you need to manage the conditions important to the comfort and productivity of the zone occupants. The ZS sensors are available in a variety of zone sensing combinations to address your application needs. These combinations include temperature, relative humidity, and indoor air quality (carbon dioxide or VOCs (Volatile Organic Compounds)). They are built to be flexible allowing for easy customization of what the user/technician sees. Designed to work with the Aurora® UPC2 controllers the ZS sensor line includes the ZS Base, ZS Plus, ZS Pro and ZS Pro-F.

The UPC2 uses a proprietary communication called Rnet to receive the space temperature from the zone sensor. This is done using (2) 18 AWG twisted pair unshielded cables for a total of 4 wires connected to the Rnet port. The sensor gets its power from the UPC2 controller and connecting multiple sensors to one UPC2 will allow for space temperature averaging. The UPC2 can support one ZS Pro or ZS Pro F with up to four ZS standard sensors wired to the Rnet port on the UPC2 for a total of 5 zone sensors. The sensors use a precise 10k ohm thermistor with less than 0.18°F drift over a ten year span, this allows for less maintenance or re-calibration after installation. The sensors also have a hidden communication port for connecting a BACview or local laptop that provides access to the equipment for commissioning and maintenance. The table below shows the features of each of the four sensors that are currently available.

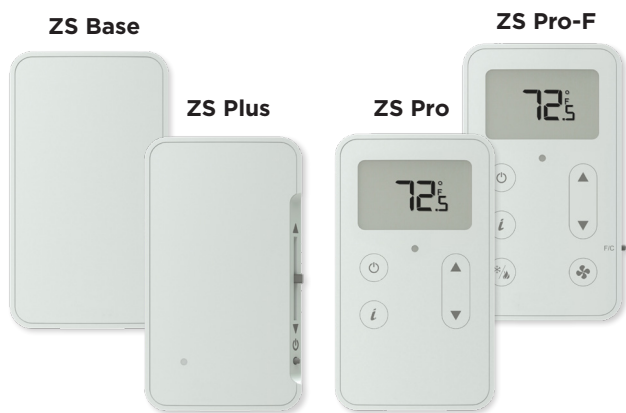

Features	ZS Base	ZS Plus	ZS Pro	ZS Pro-F
Temp, CO ² , Humidity, and VOC Options	✓	✓	✓	✓
Neutral Color	✓	✓	✓	✓
Addressable/supports daisy chaining	✓	✓	✓	✓
Hidden communication port	✓	✓	✓	✓
Mounts on a standard 2" by 4" electrical box	✓	✓	✓	✓
Occupancy Status indicator LED		✓	✓	✓
Push button occupancy override		✓	✓	✓
Setpoint adjust		✓	✓	✓
Large, easy to read LCD			✓	✓
Alarm indicator			✓	✓
°F to °C conversion button				✓

UPC2 Options	ZS Base	ZS Plus	ZS Pro	ZS Pro w/Motion	ZS Pro-F
Temperature Only	ZS2-WFI02	ZS2PL-WFI02	ZS2P-WFI02	ZS2P-M-WFI02	ZS2PF-WFI02
Temp with CO ²	ZS2-C-WFI02	ZS2PL-C-WFI02	ZS2P-C-WFI02	ZS2P-CM-WFI02	ZS2PF-C-WFI02
Temp with Humidity	ZS2-H-WFI02	ZS2PL-H-WFI02	ZS2P-H-WFI02	ZS2P-HM-WFI02	ZS2PF-H-WFI02
Temp with VOC	ZS2-V-WFI02	ZS2PL-V-WFI02	---	---	---
Temp, Humidity, CO ²	ZS2-HC-WFI02	ZS2PL-HC-WFI02	ZS2P-HC-WFI02	ZS2P-HCM-WFI02	ZS2PF-HC-WFI02
Temp, Humidity, VOC	ZS2-HV-WFI02	ZS2PL-HV-WFI02	---	---	---

Controls - UPC2 DDC Control (optional)

Note: Not all factory installed options are available, please refer to WeDoGeo® to see available options.

RNet Sensor Physical and Electrical Data

Sensing Element	Range	Accuracy
Temperature (on non-Humidity models)	-4° to 122° F (-20° C to 50° C)	±0.35° F (0.2° C)
Temperature (on Humidity models)	50° F to 104° F (10° C to 40° C)	±0.5° F (0.3° C)
Humidity	10% to 90%	±1.8% typical
CO2	400 to 1250 PPM 1250 to 2000 PPM	±30PPM or +/-3% of reading (greater of two) ±5% of reading plus 30 PPM
VOC	0 to 2,000 PPM	±100 PPM
Power Requirements	Sensor Type	Power Required
Temperature Only	All Models	12 Vdc @ 8 mA
Temperature with Humidity	All Models	12 Vdc @ 15 mA (idle) to 190 mA (CO2 measurement cycle)
Temp with VOC, or Temp/VOC/Humidity	All Models	12 Vdc @ 60 mA
Temp with CO2 , or Temp/CO2/Humidity	All Models	12 Vdc @ 15 mA (idle) to 190 mA (CO2 measurement cycle)
Power Supply	A controller supplies the Rnet sensor network with 12 Vdc @ 210 mA. Additional power may be required for your application. See sensor ZS Installation Guide	
Communication	115 kbps Rnet connection between sensor(s) and controller 15 sensors max per Rnet network; 5 sensors max per control program	
Local Access Port	For connecting a laptop computer to the local equipment for maintenance and commissioning	
Environmental Operating Range	32° to 122° F (0° - 50° C), 10% to 90% relative humidity, non-condensing	
Mounting Dimensions	Standard 4"x 2" electrical box using provided 6/32" x 1/2" mounting screws	

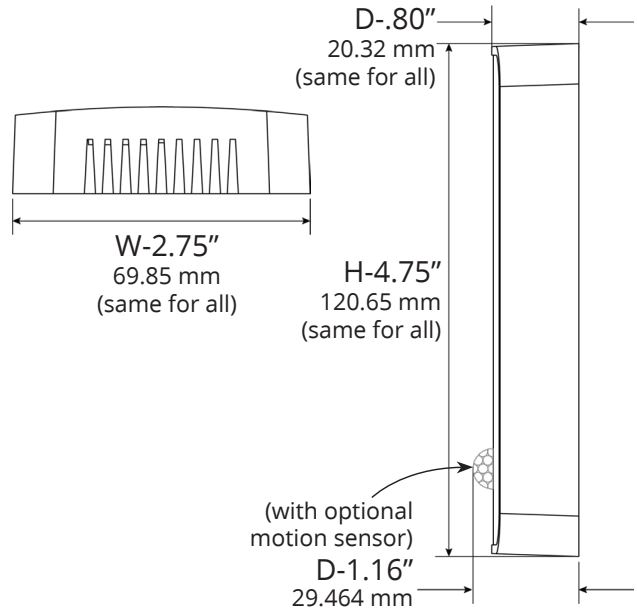
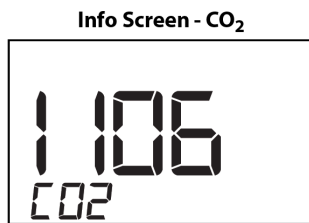
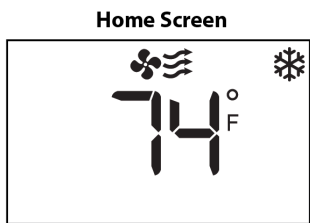
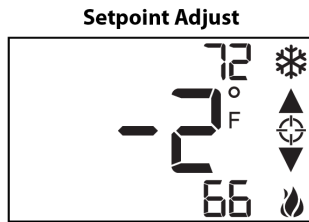
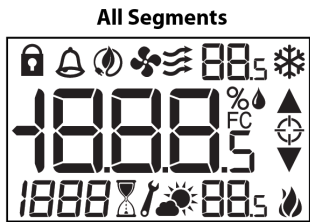

System Cleaning and Flushing

Cleaning and Flushing

Prior to start up of any heat pump, the water circulating system must be cleaned and flushed of all dirt and debris.

If the system is equipped with water shutoff valves, the supply and return runouts must be connected together at each unit location (This will prevent the introduction of dirt into the unit, see Flushing with Water Shutoff Valve Equipped Systems illustration). The system should be filled at the water make-up connection with all air vents open. After filling, vents should be closed.

The contractor should start the main circulator with the pressure reducing valve makeup open. Vents should be checked in sequence to bleed off any trapped air and to verify circulation through all components of the system.

As water circulates through the system, the contractor should check and repair any leaks found in the piping system. Drain(s) at the lowest point(s) in the system should be opened for initial flush and blowdown, making sure water fill valves are set at the same rate. Check the pressure gauge at the pump suction and manually adjust the make-up water valve to hold the same positive pressure both before and after opening the drain valves. Flushing should continue for at least two hours, or longer if required, until drain water is clean and clear.

The supplemental heater and/or circulator pump, if used, should be shut off. All drains and vents should be opened to completely drain the system. Short-circuited supply and return runouts should now be connected to the unit supply and return connections.

Refill the system with clean water. Test the system water for acidity and treat as required to leave the water slightly alkaline (pH 7.5 to 8.5). The specified percentage of antifreeze may also be added at this time. Use commercial grade antifreeze designed for HVAC systems only. Environol™ brand antifreeze is recommended.

Once the system has been filled with clean water and antifreeze (if used), precautions should be taken to protect the system from dirty water conditions. Dirty water will result in system-wide degradation of performance, and solids may clog valves, strainers, flow regulators, etc. Additionally, the heat exchanger may become clogged which reduces compressor service life and can cause premature unit failure.

Flushing with Water Shutoff Valve Equipped Systems

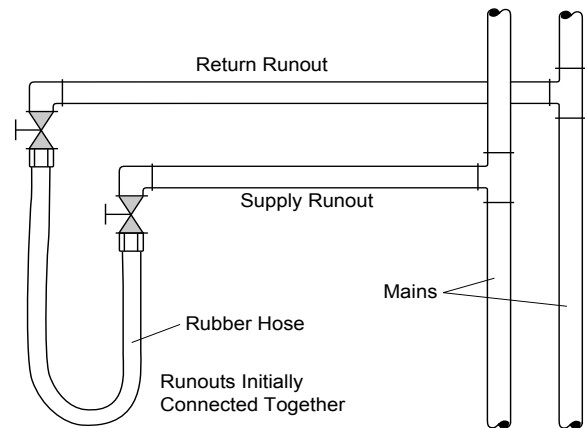

In boiler/tower application, set the loop control panel set points to desired temperatures. Supply power to all motors and start the circulating pumps. After full flow has been established through all components including the heat rejector (regardless of season), air vented and loop temperatures stabilized, each of the units will be ready for check, test and start up and for air and water balancing.

Ground Source Loop System Checkout

Once piping is completed between the unit pumping system and ground loop, final purging and charging of the loop is needed. A high pressure pump is needed to achieve adequate flow velocity in the loop to purge air and dirt particles from the loop itself. Antifreeze solution is used in most areas to prevent freezing. Flush the system adequately to remove as much air as possible; then pressurize the loop to a static pressure of 40-50 PSI (summer) or 50-75 PSI (winter). This is normally adequate for good system operation. Loop static pressure may decrease soon after initial installation, due to pipe expansion and loop temperature change. Running the unit for at least 30 minutes after the system has been completely purged of air will allow for the "break-in" period. It may be necessary to adjust static loop pressure (by adding water) after the unit has run for the first time. Loop static pressure will also fluctuate with the seasons. Pressures will be higher in the winter months than during the cooling season. This fluctuation is normal and should be considered when charging the system initially.

Ensure the pump provides adequate flow through the unit by checking pressure drop across the heat exchanger. Usually 2.25-3.0 gpm of flow per ton of cooling capacity is recommended in earth loop applications.

Refrigerant Circuit Guideline

Symptom	Head Pressure	Suction Pressure	Compressor Amp Draw	Superheat	Subcooling	Air Temp. Differential	Water Temp. Differential
Under Charged System (Possible Leak)	Low	Low	Low	High	Low	Low	Low
Over Charged System	High	High	High	Normal	High	Normal/Low	Normal
Low Air Flow Heating	High	High	High	High/Normal	Low	High	Low
Low Air Flow Cooling	Low	Low	Low	Low/Normal	High	High	Low
Low Water Flow Heating	Low/Normal	Low/Normal	Low	Low	High	Low	High
Low Water Flow Cooling	High	High	High	High	Low	Low	High
High Air Flow Heating	Low	Low	Low	Low	High	Low	Low
High Air Flow Cooling	Low	High	Normal	High	Low	Low	Normal
High Water Flow Heating	Normal	Low	Normal	High	Normal	Normal	Low
High Water Flow Cooling	Low	Low	Low	Low	High	Normal	Low
Low Indoor Air Temperature Heating	Low	Low	Low	Normal	High	Normal	Normal/High
Low Indoor Air Temperature Cooling	Low	Low	Low	Normal/Low	High	Low	Low
High Indoor Air Temperature Heating	High	High	High	Normal/High	Normal/Low	Low	Normal
High Indoor Air Temperature Cooling	High	High	High	High	Low	Low	High
Restricted TXV (Check Service Advisory)	High	Low	Normal/Low	High	High	Low	Low
Insufficient Compressor (Possible Bad Valves)	Low	High	Low	High	Normal/High	Low	Low
TXV - Bulb Loss of Charge	Low	Low	Low	High	High	Low	Low
Scaled Coaxial Heat Exchanger Heating	Low	Low	Low	Normal/Low	High	Low	Low
Scaled Coaxial Heat Exchanger Cooling	High	High	High	Normal/Low	Low	Low	Low
Restricted Filter Drier	Check temperature difference (delta T) across filter drier.						

7/6/10

Open Loop Ground Water Systems

Typical open loop piping is shown below. Always maintain water pressure in the heat exchanger by placing water control valves at the outlet of the unit to prevent mineral precipitation. Use a closed, bladder-type expansion tank to minimize mineral formation due to air exposure. Insure proper water flow through the unit by checking pressure drop across the heat exchanger and comparing it to the figures in unit capacity data tables in the specification catalog. 1.5-2 gpm of flow per ton of cooling capacity is recommended in open loop applications. Due to only minor differences in flow rate from low to high, only one solenoid valve should be used. The valve should be sized for full flow.

Discharge water from the unit is not contaminated in any manner and can be disposed of in various ways, depending on local codes, i.e. recharge well, storm sewer, drain field, adjacent stream or pond, etc. Most local codes forbid the use of sanitary sewer for disposal. Consult your local building and zoning departments to assure compliance in your area.

Open System - Groundwater Application

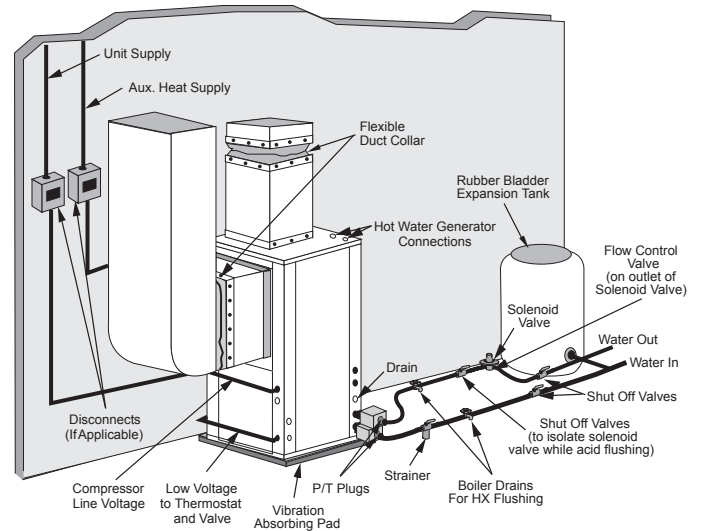

Freeze Detection

For Aurora® Base Control, set SW2-1, FP1, on the printed circuit board for applications using a closed loop antifreeze solution to 15°F [-9.4°C]. On applications using an open loop/ground water system (or closed loop no antifreeze), set this dip switch to 30°F [-1.1°C], the factory default setting. (Refer to the Dip Switch Field Selection table).

Hot Gas Reheat/Hot Gas Bypass

Hot Gas Reheat Description

The refrigerant flows in normal heat pump path in heating and cooling mode. During the Reheat mode, the operation begins with superheated vapor leaving the compressor going through the reheat valve to the reheat air coil. In the reheat coil the high temperature high pressure gas reheats the air exiting the unit to near neutral. Next, the refrigerant exits the reheat coil and passes through a check valve, which is used to prevent refrigerant flow into the reheat coil during normal heating and cooling operation. The refrigerant passes through the check valve and is then diverted to the coaxial heat exchanger by the four way reversing valve. The hot gas enters the coaxial heat exchanger which will condense the gas to a high pressure liquid due to heat being rejected to the loop fluid. The high pressure liquid leaves the coax and enters the inlet of the TXV. After passing through the TXV the low pressure mixture of liquid/vapor refrigerant expands in the air coil evaporating into a low pressure low temperature gas and moves back through the reversing valve and into the compressor suction. The cycle then starts again by compressing the low pressure low temperature gas into a superheated vapor. A small copper bleed line is located on the reheat/reclaim valve to allow refrigerant that has migrated to the reheat coil to escape.

Hot Gas Bypass Description

The hot gas bypass (HGB) option is designed to limit the minimum evaporating pressure in the cooling mode to prevent the air coil from icing. The HGB valve senses pressure at the outlet of the evaporator by an external equalizer. If the evaporator pressure decreases to 115 psig the HGB valve will begin to open and bypass hot discharge gas into the inlet of the evaporator. The valve will continue to open as needed until it reaches its maximum capacity. Upon a rise of suction pressure, the valve will begin to close back off and normal cooling operation will resume.

Hot Gas Reheat/Hot Gas Bypass cont.

Hot Gas Reheat Dehumidification Overview Dehumidification - The Need for Reheat

With tighter construction and more and more ventilation air being introduced into buildings, there is more need now than ever for proper humidity control. Ensuring dehumidification can provide consistent employee comfort, a reduction in mold liability, a reduction in cooling costs. Reduced humidity also provides an improvement in indoor air quality (IAQ) thru lower humidity levels which can reduce allergen levels, inhibit mold and bacterial growth, and provide an improved computer environment. ASHRAE 90.1 speaks of an acceptable humidity range in all commercial buildings.

Typical Reheat Applications

Reheat can be used wherever moisture is a problem. Schools, high latent auditorium and theaters, makeup air units*, and computer rooms are typical applications. Although reheat equipped water source heat pumps (wshp's) can condition limited amounts of outdoor air, the percentage of this outdoor air should never exceed 50% of the return air to the unit limiting the mixed return air temperature to a minimum of 50°F. When cold entering air conditions are anticipated, hot gas bypass option should be considered to prevent air coil freeze up.

*A dedicated outdoor air system (DOAS) should be investigated for 100% outdoor air applications.

The Design of Reheat Equipment

Hot gas reheat can help maintain specific humidity levels and neutral air in a building. ASHRAE recommends a relative humidity range of 30-60% with levels greater than 65% making mold growth a possibility. The dehumidification relative humidity set points of 57% (on) and 52% (off) are recommended. During reheat the leaving air temperature (LAT) will approximate neutral air. The included chart (Leaving Air Temperature vs. Entering Water and Air Conditions Chart) shows the LAT vs entering water temperature (EWT) to the unit at differing entering air conditions. At 86-90°F EWT the unit will provide nearly neutral air.

Moisture Removal Capacity

The amount of moisture removal may be calculated by subtracting the sensible cooling capacity from the total cooling capacity in the equipment performance data of the specifications catalog or submittal data. An example is shown below:

Model NB*048, 1275 cfm, 12 gpm, 90°F EWT

$$TC - SC = LC$$

$$46.5 - 34.6 \text{ MBtu/h} = 11.9 \text{ MBtu/h}$$

Where TC = total cooling capacity, SC=sensible capacity, LC=latent capacity

Leaving Air Temperature vs. Entering Water and Air Conditions Chart

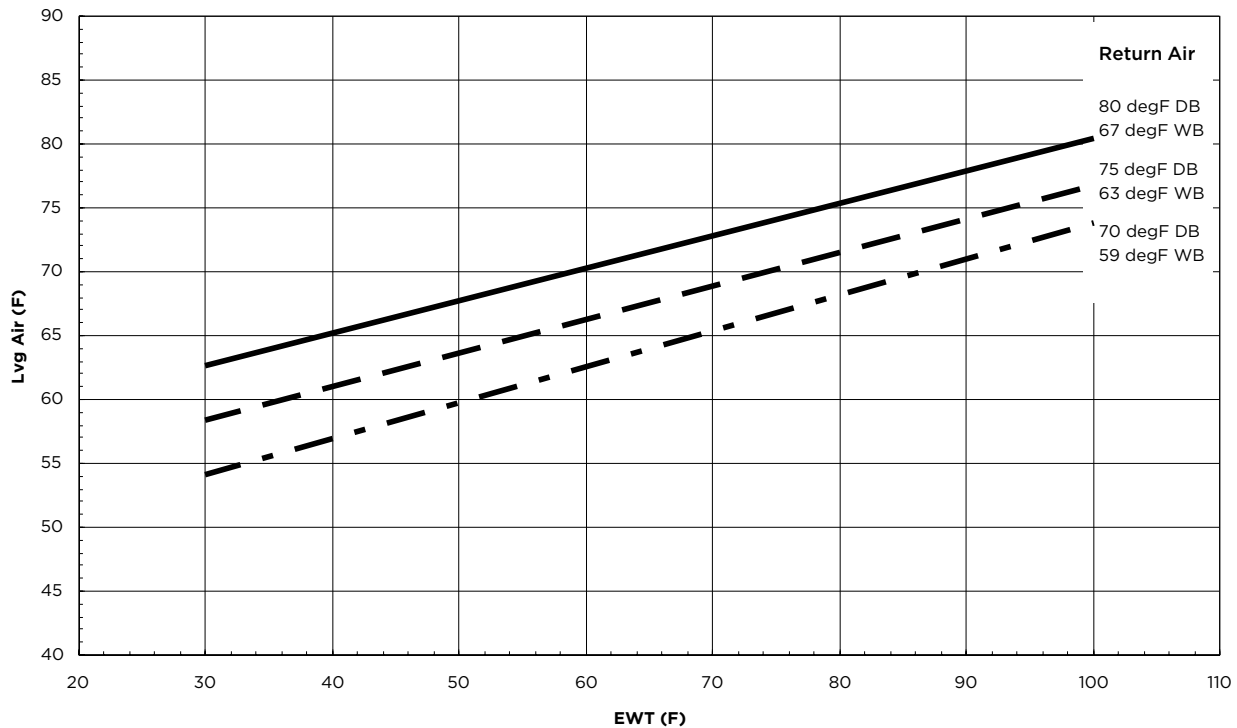

Hot Gas Reheat/Hot Gas Bypass cont.

Hot Gas Reheat Dehumidification Overview cont.

Btu/hr may be converted to lbs/hr or grains per hour as shown in the equations below.

$$11,900 \text{ Btu/h} / 1,069 \text{ Btu/lb of water vapor at } 80/67 \text{ DB/WB}^\circ\text{F} = 11.13 \text{ lbs/hr}$$

$$11.13 \text{ lbs/hr} \times 7,000 \text{ grains/lb} = 77,910 \text{ grains/hr}$$

External Static Pressure Adjustment

With a reheat coil option installed an adjustment for external static pressure (ESP) needs to be made. The following table will show the reduction in ESP for any model relating coil air velocity and ESP.

ESP vs. Coil Velocity Table

Coil Velocity (fpm)	250	300	350	400
ESP Increase (in. wg.)	0.10	0.14	0.17	0.20

Variable speed ECM models will generally compensate up to their maximum ESP of 0.5 in. wg. for 1/2 hp and 0.75 in. wg. for 1 hp.

Model NBH048, 1500 cfm,

$$H \times W = SA$$

$$20 \times 40 = 800 \text{ in.}^2 = 5.56 \text{ ft.}^2$$

Where H=fin height of air coil, W=fin length of air coil, SA=fin surface area

Adjustment must be made for dehumidification mode, 85% of cfm,

$$1500 \times 0.85 = 1,275 \text{ cfm}$$

Calculate air velocity, fpm, cfm / SA

$$1,275 \text{ cfm} / 5.56 \text{ ft.}^2 = 229 \text{ fpm}$$

Refer to the ESP vs. Coil Velocity Table and look up the fpm to find ESP increase. If air velocity is below 250 cfm assume 0.10 increase in ESP. Interpolation of data within the table is permitted.

Hot Gas Bypass with Hot Gas Reheat Layout

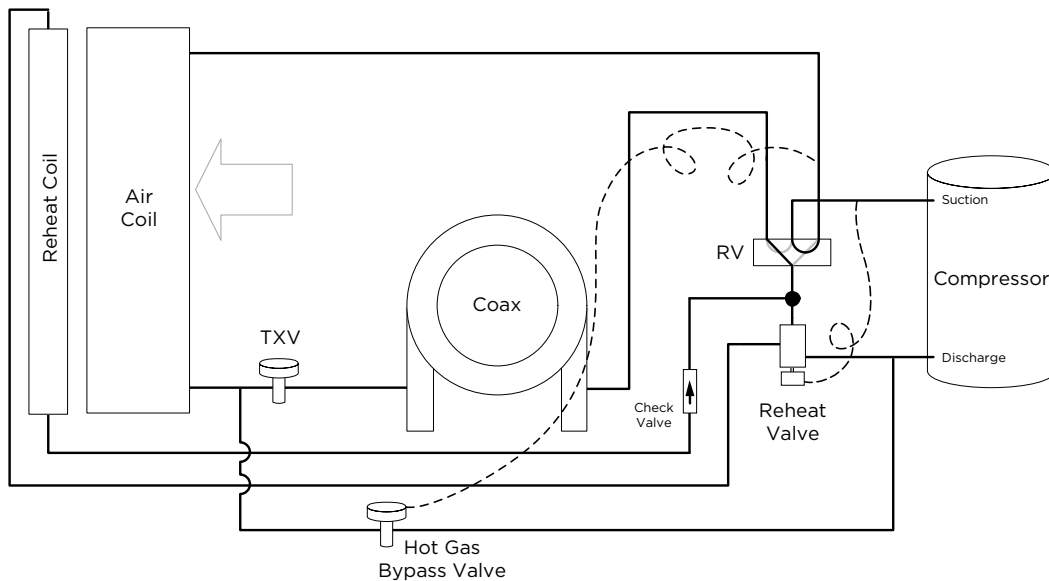

Compressor and Thermistor Resistance

Model	208-230/60/1		265/60/1		208-230/60/3	460/60/3	
	Run	Start	Run	Start			
Single Speed	009	2.48	3.17	2.56	3.08		
	012	2.2	3.29	2.56	3.08		
	015	2.15	2.28	1.93	2.16		
	018	1.81	2.21	1.93	2.16		
	024	1.068	1.749	1.414	1.611	1.590	6.079
	030	0.89	1.567	1.025	1.383	1.423	4.565
	036	0.787	1.336	0.996	1.368	.975	4.266
	042	0.568	1.636			1.117	4.404
	048	0.464	1.296			.796/.975/.796	3.52/4.32/3.52
	060	0.39	0.782			.629/.772/.629	3.44
072	0.336	0.921			.542	2.161	
Dual Capacity	018	1.20 - 1.38	1.66 - 1.91	n/a	n/a	n/a	n/a
	024	0.99 - 1.14	1.54 - 1.77	1.38 - 1.58	2.02 - 2.32	2.00 - 2.30	8.00 - 9.20
	030	0.74 - 0.85	1.68 - 1.93	1.01-1.16	1.72-1.98	1.41	4.5
	036	0.67 - 0.78	1.37 - 1.57	1.13 - 1.31	1.07 - 1.23	1.42 - 1.64	5.46 - 6.28
	042	0.48 - 0.55	1.29 - 1.49	n/a		0.92	3.327-4
	048	0.41 - 0.47	1.54 - 1.78	n/a		0.96 - 1.10	3.88 - 4.46
	060	0.35 - 0.41	1.34 - 1.55	n/a		0.63 - 0.73	2.98 - 3.42
	072	0.31 - 0.35	1.30 - 1.50	n/a		0.56 - 0.64	2.34 - 2.70

5/7/24

Thermistor Temperature (°F)	Microprocessor Resistance (Ohms)
5	75757-70117
14	57392-53234
23	43865-40771
32	33809-31487
41	26269-24513
50	20570-19230
59	16226-15196
68	12889-12093
77	10310-9688
86	8300-7812
95	6723-6337
104	5480-5172
113	4490-4246
122	3700-3504
131	3067-2907
140	2554-2424
149	2149-2019

7/6/10

Troubleshooting Checklist

Equipment will not start or operate

- Follow the troubleshooting flow charts to find root cause.

High pressure lockout in the heating mode

- Check for air flow interruption from one or more of the following: inoperative blower, dirty filters or air coil, blocked return air grill, closed or blocked supply registers, restricted supply or return duct, zone dampers, etc. If airflow is suspected as being a problem, make a quick check using the following example: Velocity in a supply duct should not exceed 1000 fpm and 700 fpm in return ducts. For this example we will use an model 038 which has a maximum rating of 1500 cfm at 0.50 static (Refer to the blower performance tables in the install manual for your particular piece of equipment). Using the formula: Area in square feet equals quantity in cfm divided by velocity in fpm ($A = \text{cfm}/\text{fpm}$), 1.57 sq. ft. is needed for the supply duct and 2.14 sq. ft. is needed for the return duct. Refer to the troubleshooting flow charts if a problem with the blower motor or logic board is suspected.
- Check for blocked or seized expansion valve assembly.
- Make sure the discharge pressure is within the operating range shown in the product install manual.
- The unit may be overcharged; check superheat and sub cooling. If this problem is verified, recharge using approved methods.

High pressure lockout in the cooling mode

- Water flow may be restricted or inadequate. Verify in accordance with the pressure drop tables shown in product install manual. Also, look for the following: solenoid valve may not be opening on well water units, pump(s) may be inoperative in the flow center, debris may be blocking coil (back flush using at least 20 PSI), or air may be in the loop (flush loop).
- Water to refrigerant heat exchanger may be fouled with debris. If so, back flush with at least 20 psi of water pressure.
- If mineral accumulation is evident, clean the heat exchanger with acid.
- Entering air temperature may be too high. Equipment is designed for a maximum of 85°F DB and 71°F WB.
- Check for a seized or blocked expansion valve assembly.
- The unit may be overcharged; check superheat and sub cooling. If this problem is verified, recharge using approved methods.

Low pressure lockout in heating mode

- If equipment is installed in a low temperature area (below 50°F), install a crankcase heater, then protect the unit from the elements.

- Water flow may be restricted or inadequate. Verify in accordance with the pressure drop tables shown in product install manual. Also, look for the following: solenoid valve may not be opening on well water units, pump(s) may be inoperative in the flow center, debris may be blocking coil (back flush using at least 20 PSI), or air may be in the loop (flush loop).
- Check for a seized or blocked expansion valve assembly.
- Return air temperature may be below 50°F. Block off air coil temporarily to improve flow of refrigerant through the system. Air below 50°F cannot be tolerated on a continuing basis. Correct the problem.
- Refrigerant may be low. Check for leaks, reclaim refrigerant, repair if necessary, recharge using approved methods.

Low pressure lockout in the cooling mode

- Check for inadequate air flow. Follow the same procedure as shown for a high pressure lockout in the heating mode.
- Check for a seized or blocked expansion valve assembly.
- Refrigerant charge may be low.

Water flow lockout in either the heating or cooling mode

- Water flow may be restricted or inadequate. Verify in accordance with the pressure drop tables shown in product install manual. Also, look for the following: solenoid valve may not be opening on well water units, pump(s) may be inoperative in the flow center, debris may be blocking coil (back flush using at least 20 PSI), or air may be in the loop (flush loop).
- Disconnect freeze sensor from control and measure the resistance. Cross reference with the Thermistor Data table.

Condensate over flow lockout in either the heating or cooling mode

- Make sure the drain line pitches away from the unit. Install a vertical vent on horizontal drain lines over six feet long. Clean condensate pan and be sure outlet and drain line from the condensate pan is clear.

Reversing valve does not operate

- Disconnect solenoid and check for continuity across coil. Replace coil if continuity is not found.
- If stuck reversing valve is suspected, restrict airflow in heating mode (to build pressure), then switch immediately to the cooling mode.

Control Board Troubleshooting Steps

1) General Check

- If any new device was installed, or any wiring was changed, check the connections to ensure the wiring is correct, and all the wires are in good condition.
- Verify all the plugs are securely connected and in good condition.
- Check the DIP switch (SW2) positions are correct.
- Measure 24 VAC between R and C. (The actual reading may be from 18 to 30 VAC). Check the incoming power and the power transformer if the R and C voltage reading is not correct.

2) No LEDs are On

- Check 24 VAC on board.
- Check the 3 amp fuse. Replace the fuse if needed.
- Verify transformer circuit breaker has not tripped if no low voltage is present.
- Disconnect the thermostat connection P1.
- Replace the Aurora® base control board.

3) Red LED Flash Code

Input Fault (Code 1) – Indicates that both O and W input signals are present. Disconnect the thermostat connector from the ABC board and then cycle power to the board. If the fault does not reappear, then the problem is between the thermostat and the thermostat connector. Otherwise, replace the ABC board.

High Pressure Fault (Code 2) – Indicates the system pressure has exceeded 600 psi (R-454B) which may have been caused by low water flow in cooling, (check coaxial heat exchanger for mineral build-up) or low air flow in heating (check filters and coil for dirt build-up). Measure P4-9 and C is 24 VAC. If not, replace ABC. Check the heat pump refrigeration system. Cycle the power to reset the system. Measure P4-10 and C is 24 VAC. If not, replace the high pressure sensor.

Low Pressure Fault (Code 3) – Indicates low pressure switch has opened which may indicate a loss of system charge, system restriction, or frozen heat exchanger. Measure P4-7 and C is 24 VAC. If not, replace ABC. Check the heat pump refrigeration system. Cycle the power to reset the system. Measure P4-8 and C is 24 VAC. If not, replace the low pressure sensor. Refrigerant may be low. Check for leaks, reclaim refrigerant, repair if necessary, pump down and recharge the system to the quantity of refrigerant shown on the unit nameplate.

Freeze Detection 1 Fault (Code 5) – Indicates low or no water flow; low system charge; or faulty TXV in heating mode. Make sure the DIP switch FP1 (SW2-1) selection matches the application. Measure the temperature on the refrigerant line next to the freeze detection thermistor. Disconnect the connector P4. Measure the resistance reading between P4-3, P4-4. Refer to the Thermistor Data table, find the corresponding temperature data. Compare the data with the temperature measurement from the refrigerant line. The temperature should be within +/- 2° F. If not, replace the thermistor.

Other items to check when troubleshooting a water flow lockout are superheat, water flow through the coaxial heat exchanger and antifreeze composition. High superheat in heating will lower the refrigerant line temperature where the freeze detection thermistor is located. In this case, check the TXV. Closed loop systems are rated at 3 gpm/ton. If a closed loop system is running at less than 3 gpm/ton, the temperature difference between the refrigerant line and the actual leaving water temperature will be greater and could lead to possible water flow lockouts.

Condensate Fault (Code 7) – Indicates condensate water in the drain pan fills up and touches the spade terminal. Make sure the drain line pitches away from the unit. Install a vertical vent on horizontal drain lines over six feet long. Clean and be sure outlet and drain line from the condensate pan is clear. Jumper between R, Y2 and O to start 2nd stage cooling. Observe the water level in the drain pan. If the unit is locking out on condensate and the drain pan is dry, remove the condensate wire from the drain pan and tape it out of the way. Be careful to not ground the wire out because that will cause the unit to lockout on drain overflow. If the unit is still locking out, check the brown wire all the way back to the ABC for a short to ground. Remember that the condensate sensor is just a wire looking for a ground. If it touches any metal in the cabinet, the unit will see that as a drain fault. If removing the wire from the drain pan stopped the false drain lockouts, put the condensate sensor back in place in the drain pan. Pay close attention to how far the spade terminal sits down in the drain pan. If the terminal is pushed all the way down so that it is touching the bottom of the drain pan, this will cause a drain lockout if there is any trace of water. If the spade terminal fits loosely in the drain pan, spread the terminal open to make it fit snugly in the drain pan.

Over/Under Voltage Shutdown Fault (Code 8) – Indicates the control voltage is or had been outside the range of 18 to 30 VAC for more than 15 minutes. Using a voltage meter, check the incoming power line voltage is within + or - 25%. If not, there is a power line issue. Check the secondary of the control transformer with a voltage meter. The voltage should be 18 to 30 VAC. If not, replace the control transformer.

Freeze Detection FP1 Sensor Fault (Code 11) – Indicates the freeze detection sensor is out of range. Disconnect the connector P4. Measure the resistance reading between P4-3, P4-4. Refer to the Thermistor Data table, find the corresponding temperature data. Compare the data with the temperature measurement from the refrigerant line. The temperature should be within +/- 2°F. If not, replace the thermistor.

4) Other Faults

ECM Motor Will Not Start

1. Measure the voltage output between P13-1 and P13-5. Reference the chart below for blower speed vs. voltage.

Control Board Troubleshooting Steps cont.

Blower Speed Selection Number	DC Volts
1	0.6 VDC
2	2.7 VDC
3	4.6 VDC
4	7.5 VDC
5	9.8 VDC
6	12.5 VDC
7	14.4 VDC
8	16.3 VDC
9	18.5 VDC
10	21.2 VDC
11	22.3 VDC
12	23.4 VDC

1. Measure the voltage from C to F terminals (P5-2). The reading should be 24VAC.

Compressor First Stage Will Not Start – Measure the voltage output between P5-4 and P5-5, P5-7 and P5-8. The reading should be 24 VAC. If 24 VAC is not present check transformer output, thermostat wiring, current fault status, etc.

Compressor Second Stage Will Not Start – Measure the voltage output between P5-6 and P5-8. The reading should be 24 VAC. If 24 VAC is not present, check DIP switch settings, thermostat operation, and thermostat wiring.

PSC Motor Will Not Start – Measure the voltage output between P5-2 and P5-3. The reading should be 24 VAC.

No Alarm Output – Measure the voltage output between P2-4 and C. The reading should be 24 VAC or a pulsed 24 VAC dependent on the selection of SW2-7. If SW2-8 is set for reheat, the alarm output will be used to control the hot gas reheat valve and will not show lockout information.

Accessory Relay Does Not Operate – Measure the continuity between P2-2 and P2-3. It should read closed when relay is engaged. If this is not correct, check SW2-4 and SW2-5 settings.

No Lockout Output – Measure the voltage output between P1-1 and C. The reading should be 24 VDC or a pulsed 24 VDC dependent on the selection of SW2-7. If voltage is not present, make sure the unit is in lockout and not fault retry.

Auxiliary Heater Does Not Function – Measure the voltage output between P3-1, P3-2, and P3-3, P3-4. The output should be 24 VDC. If voltage is not present, check thermostat operation and wiring.

Loop Pump Does Not Start – The loop pump is controlled by the AXB board. Check to make sure the control board is powered by taking a voltage reading across R and C to check for 24VAC. If 24VAC is not present check the wiring connections, 24VAC is supplied to the AXB through the harness connected to P9. Next check to make sure the ABC is attempting to run the compressor, the loop pump will only run when the ABC is commanding CC on, the pump slave input is active, or the AXB has lost communication with the ABC. Please refer to troubleshooting flow charts for additional checks on the loop pump.

5) Operation Modes

Enter First Stage Heating – Remove P1. Place a jumper between R and Y1.

Enter Second Stage Heating – Remove P1. Place a jumper between R, Y1 and Y2. This is for SW2-6 set to “OFF” position.

Enter Third Stage Heating – Remove P1. Place a jumper between R, Y1, Y2 and W.

Enter First Stage Cooling – Remove P1. Place a jumper between R, O and Y1.

Enter Second Stage Cooling – Remove P1. Place a jumper between R, O, Y1 and Y2.

Enter Emergency Heating – Remove P1. Place a jumper between R and W.

Enter Blower Only Mode – Remove P1. Place a jumper between R and G.

Enter Reheat Mode – Remove P1. Place a jumper between R and DH. (SW2-8 must be off)

These notes are for SW2-3 set to “ON” position.

Control Board Troubleshooting Flow Charts

Use the following flow charts to aid in troubleshooting the control board.

Compressor Will Not Start Without AID Tool

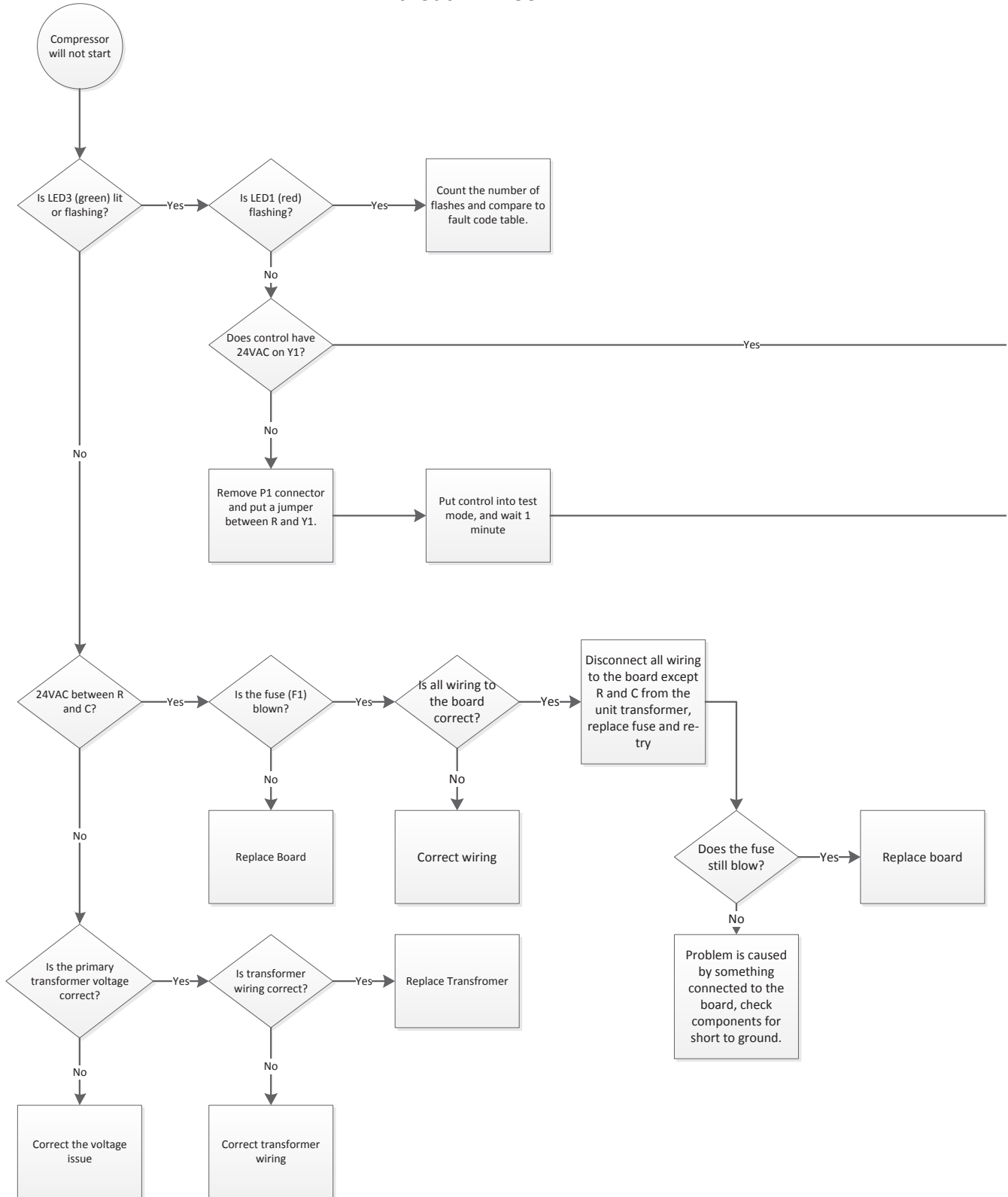

Control Board Troubleshooting Flow Charts cont.

Notes:

1. When measuring 24VAC actual value may be between 18 and 30VAC.

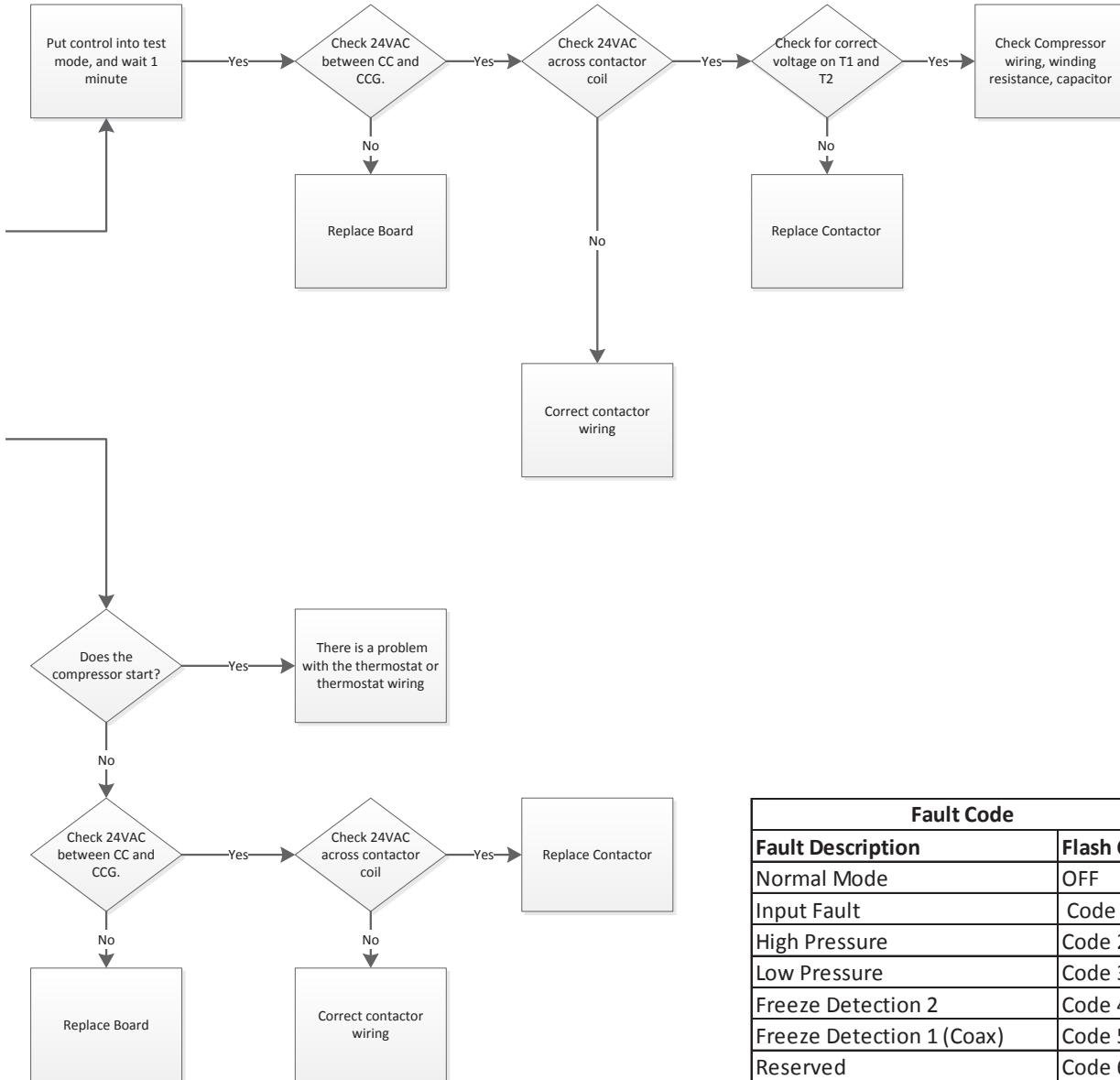

Fault Code	
Fault Description	Flash Code
Normal Mode	OFF
Input Fault	Code 1
High Pressure	Code 2
Low Pressure	Code 3
Freeze Detection 2	Code 4
Freeze Detection 1 (Coax)	Code 5
Reserved	Code 6
Condensate	Code 7
Over/Under Voltage	Code 8
Not Used	Code 9
Freeze Detection Sensor Error	Code 11

NOTE: Refer to the Control Board Troubleshooting Steps for fault descriptions.

Control Board Troubleshooting Flow Charts cont.

Compressor Will Not Start With AID Tool

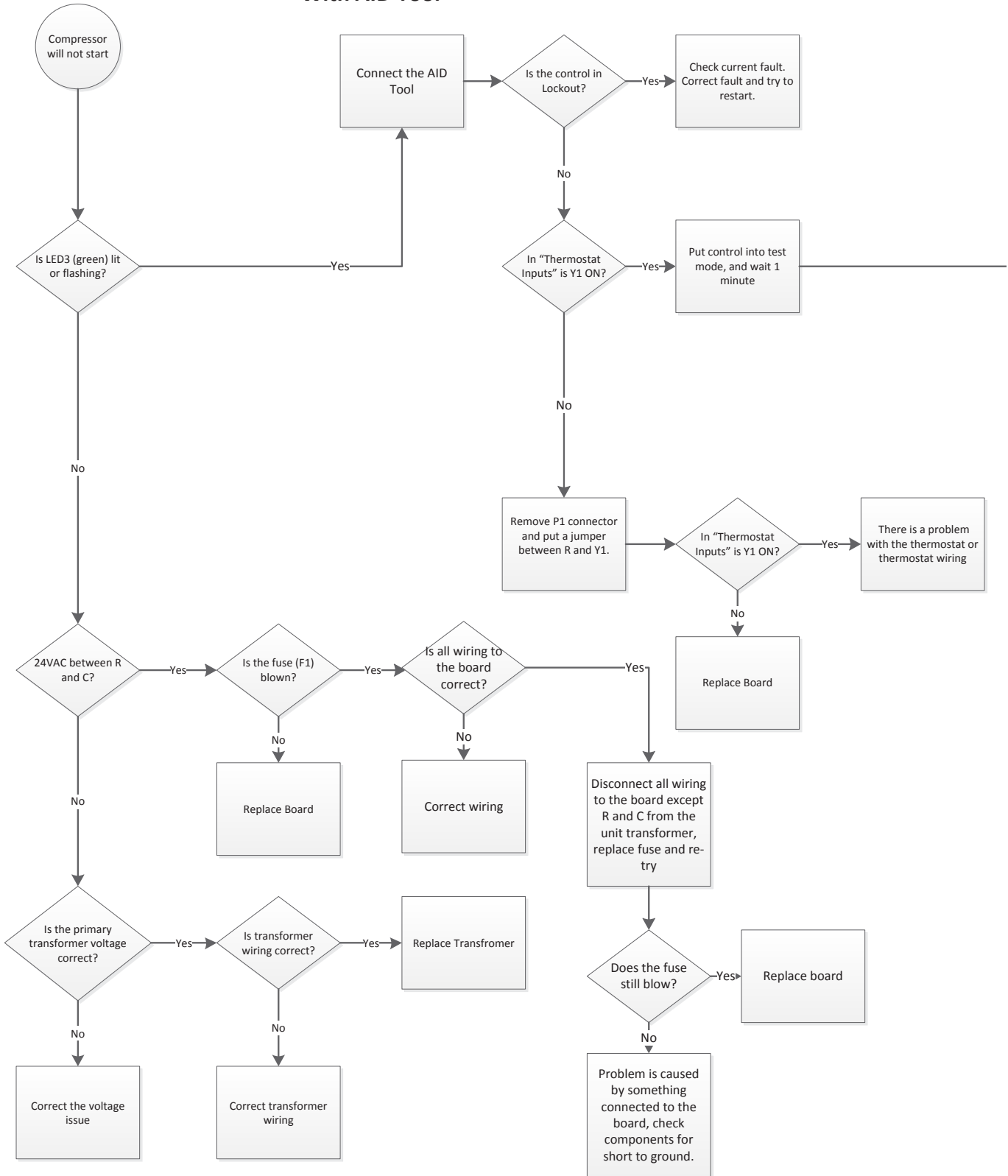

Control Board Troubleshooting Flow Charts cont.

Notes:

1. When measuring 24VAC actual value may be between 18 and 30VAC.

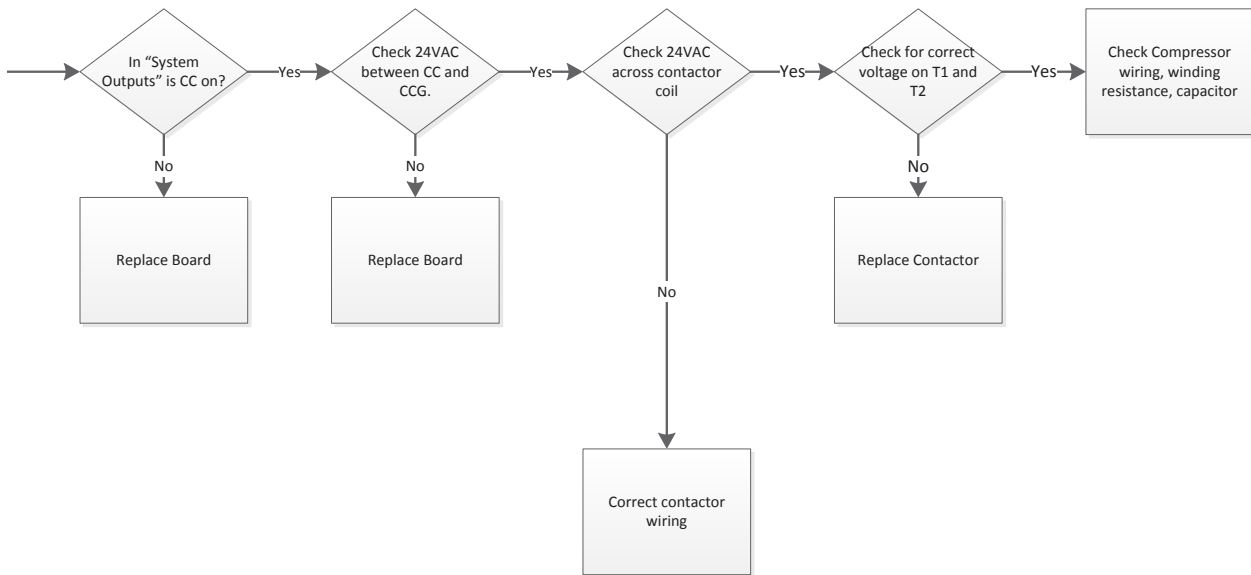

Control Board Troubleshooting Flow Charts cont.

ECM Blower Will Not Start Without AID Tool

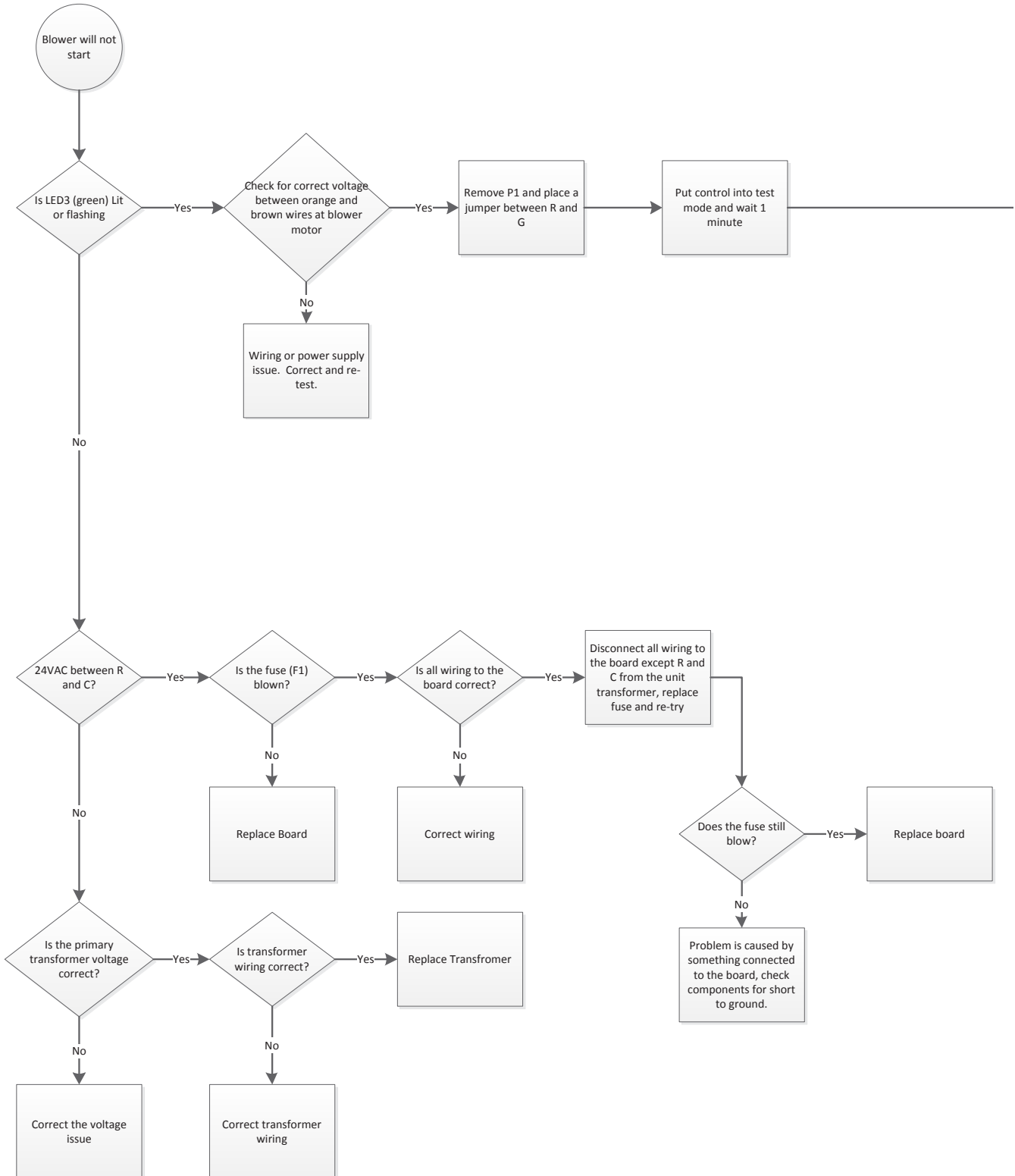

Control Board Troubleshooting Flow Charts cont.

Notes:

1. When measuring 24VAC actual value may be between 18 and 30VAC.

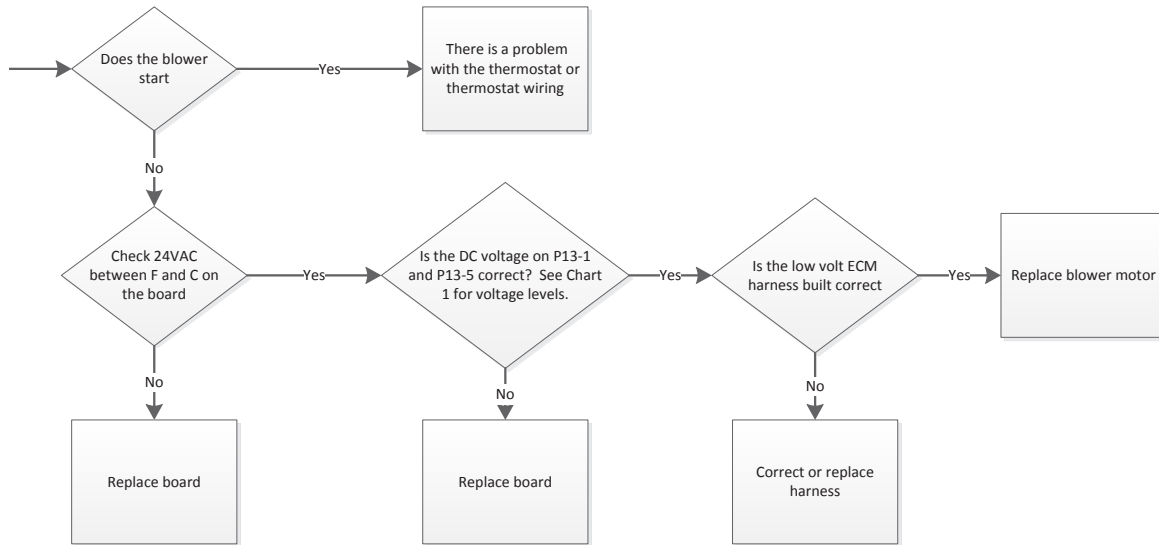
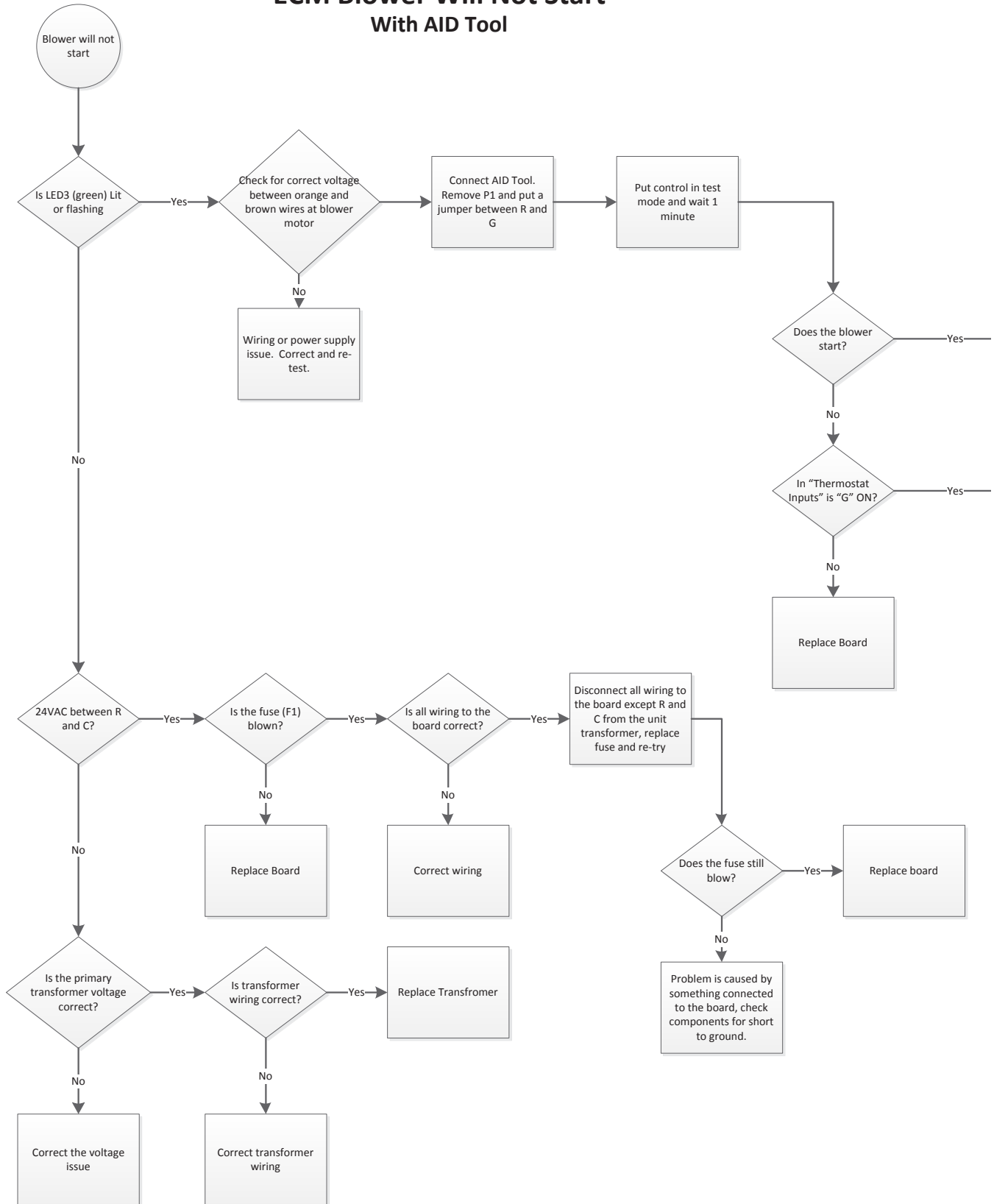

Chart 1

Blower Speed Selection Number	DC Volts
1	0.6VDC
2	2.7VDC
3	4.6VDC
4	7.5VDC
5	9.8VDC
6	12.5VDC
7	14.4VDC
8	16.3VDC
9	18.5VDC
10	21.2VDC
11	22.3VDC
12	23.4VDC

Control Board Troubleshooting Flow Charts cont.

ECM Blower Will Not Start With AID Tool



Control Board Troubleshooting Flow Charts cont.

Notes:

1. When measuring 24VAC actual value may be between 18 and 30VAC.

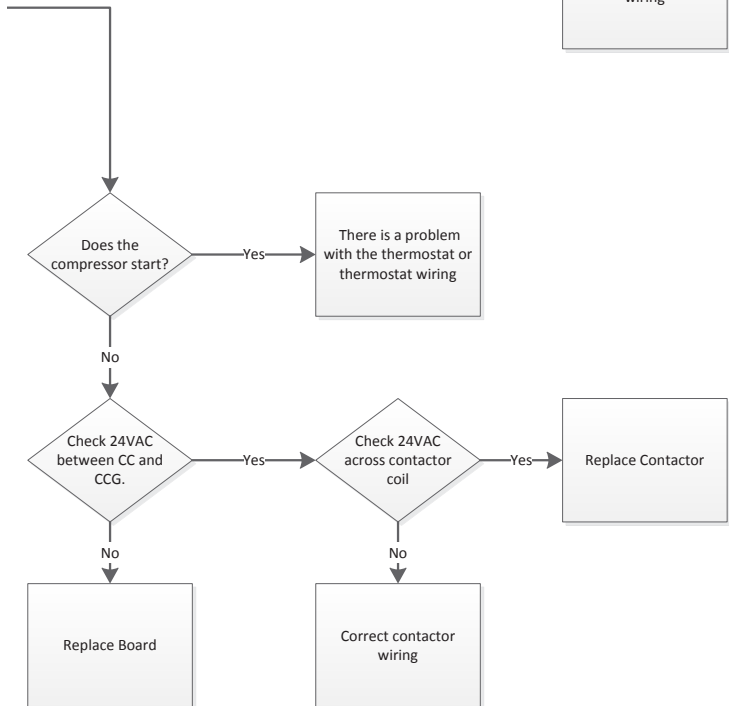
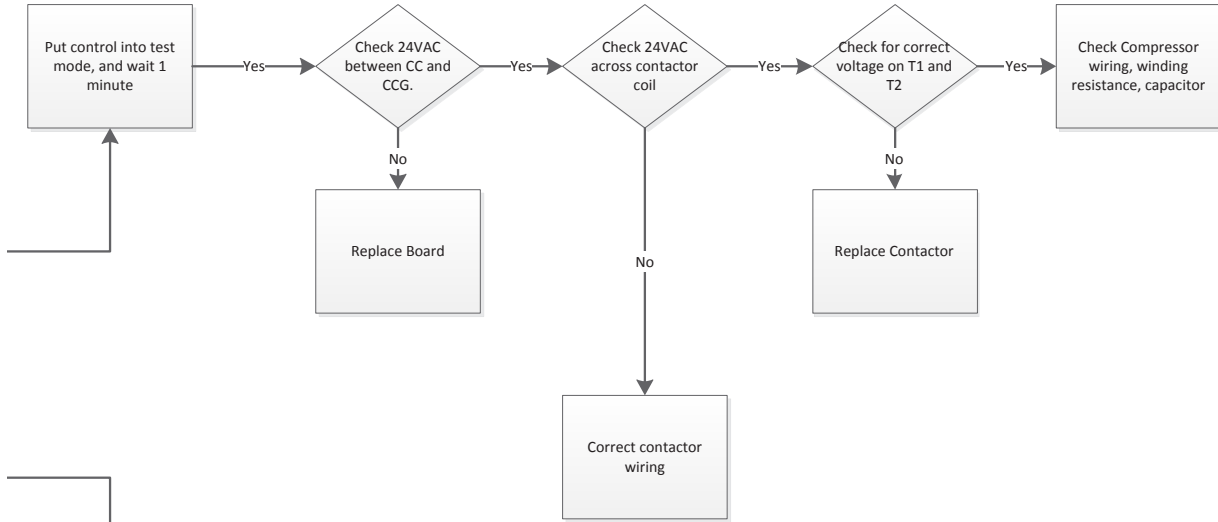

Fault Code	
Fault Description	Flash Code
Normal Mode	OFF
Input Fault	Code 1
High Pressure	Code 2
Low Pressure	Code 3
Freeze Detection 2	Code 4
Freeze Detection 1 (Coax)	Code 5
Reserved	Code 6
Condensate	Code 7
Over/Under Voltage	Code 8
Not Used	Code 9
Freeze Detection Sensor Error	Code 11

Control Board Troubleshooting Flow Charts cont.

Loop Pump Will Not Start Variable Speed Pump

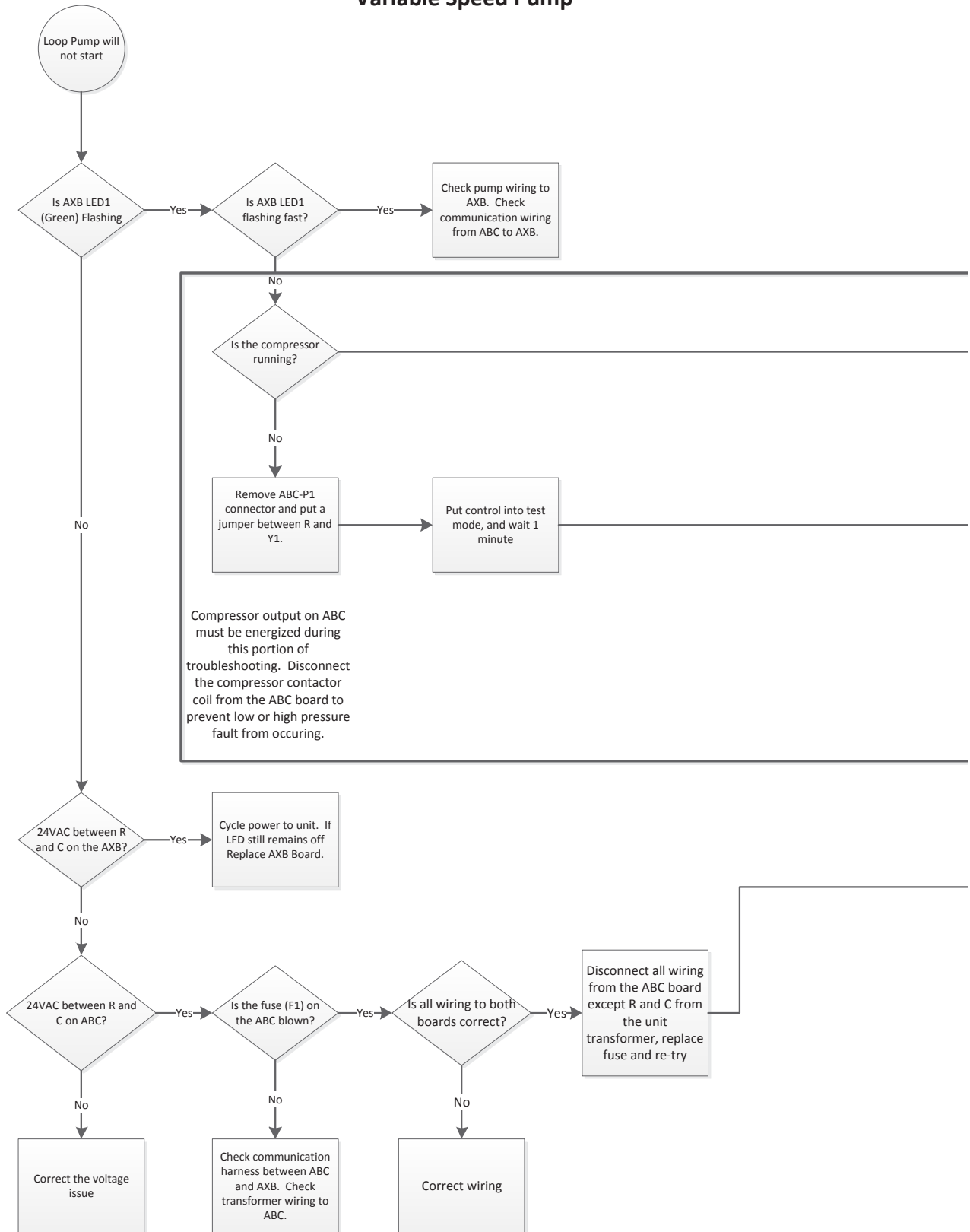

Control Board Troubleshooting Flow Charts cont.

Notes:

1. When measuring 24VAC actual value may be between 18 and 30VAC.
2. When measuring 240VAC actual value may be between 190 and 250 VAC.

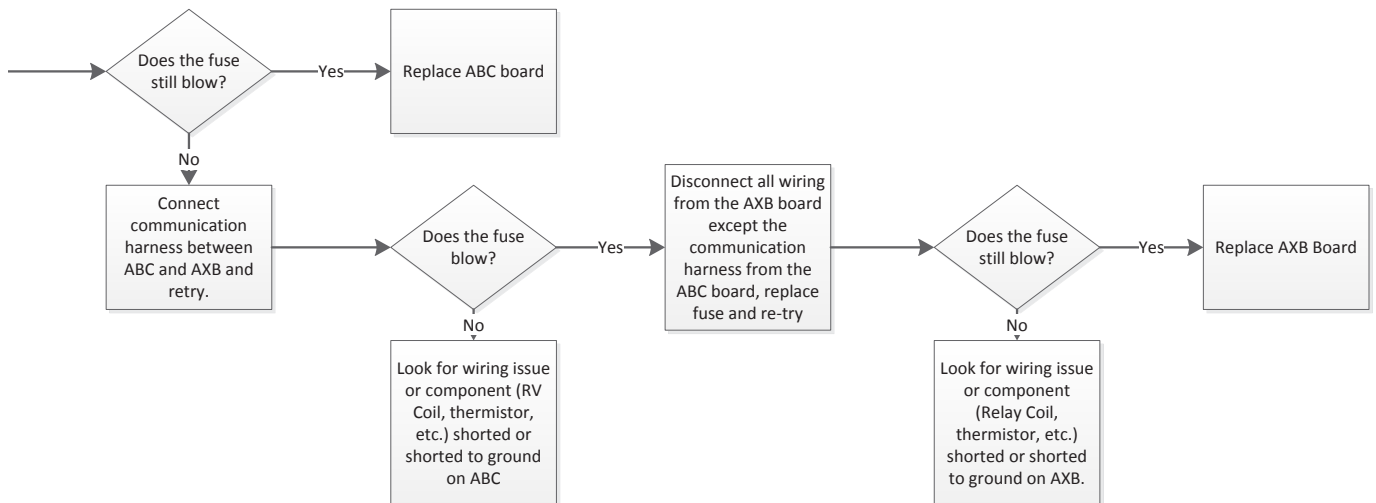
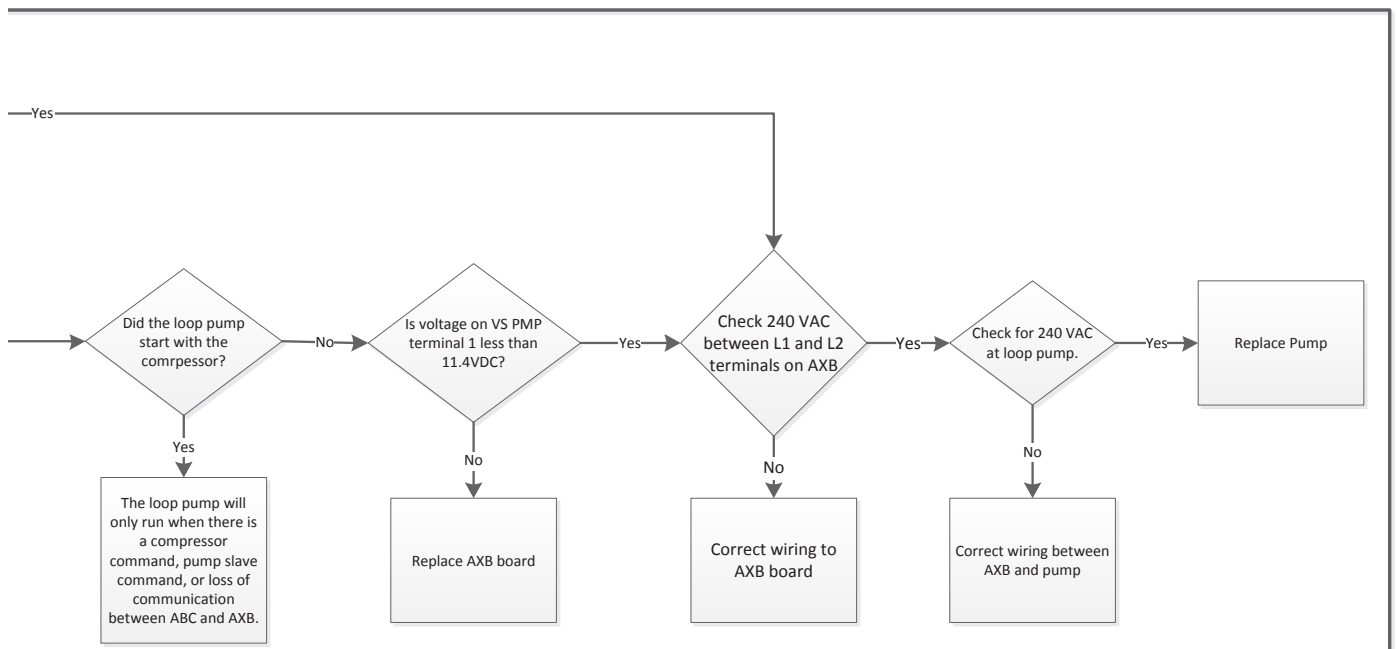

Control Board Troubleshooting Flow Charts cont.

Loop Pump Will Not Start Non Variable Speed Pump

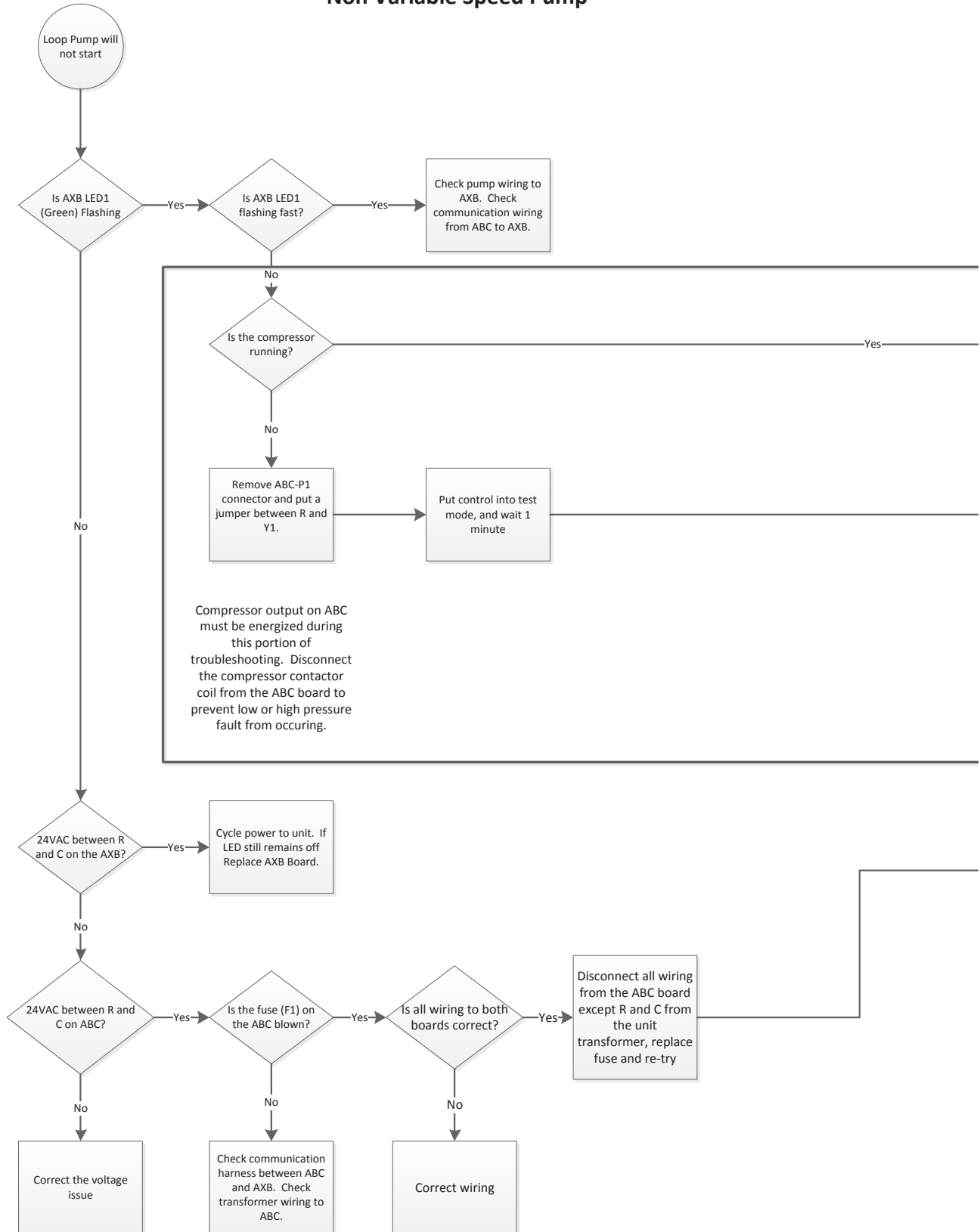

Control Board Troubleshooting Flow Charts cont.

Notes:

1. When measuring 24VAC actual value may be between 18 and 30VAC.
2. When measuring 240VAC actual value may be between 190 and 250 VAC.

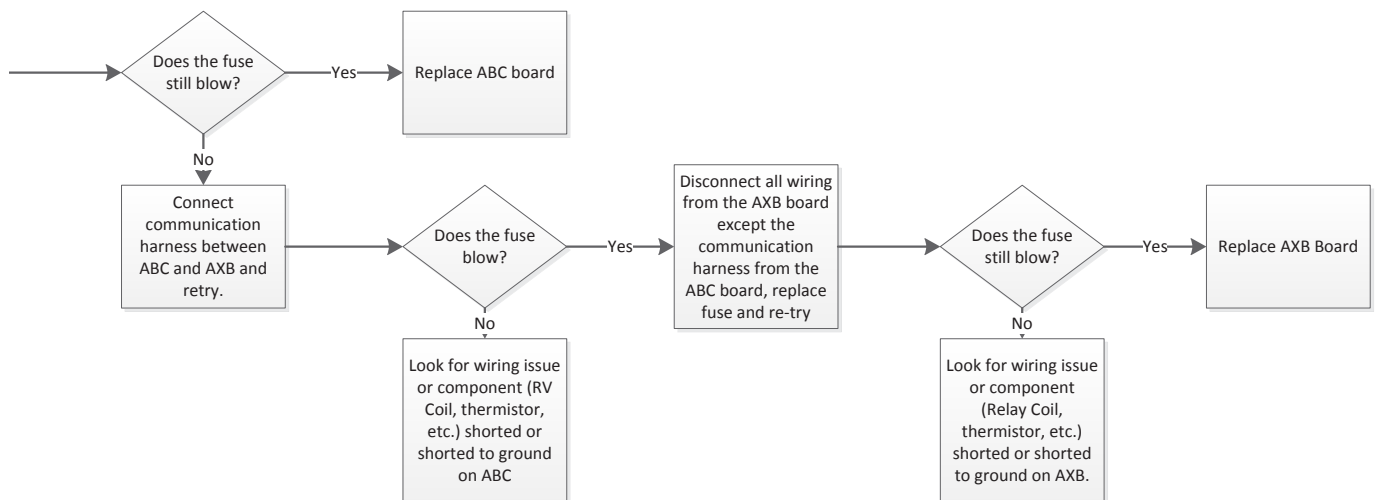
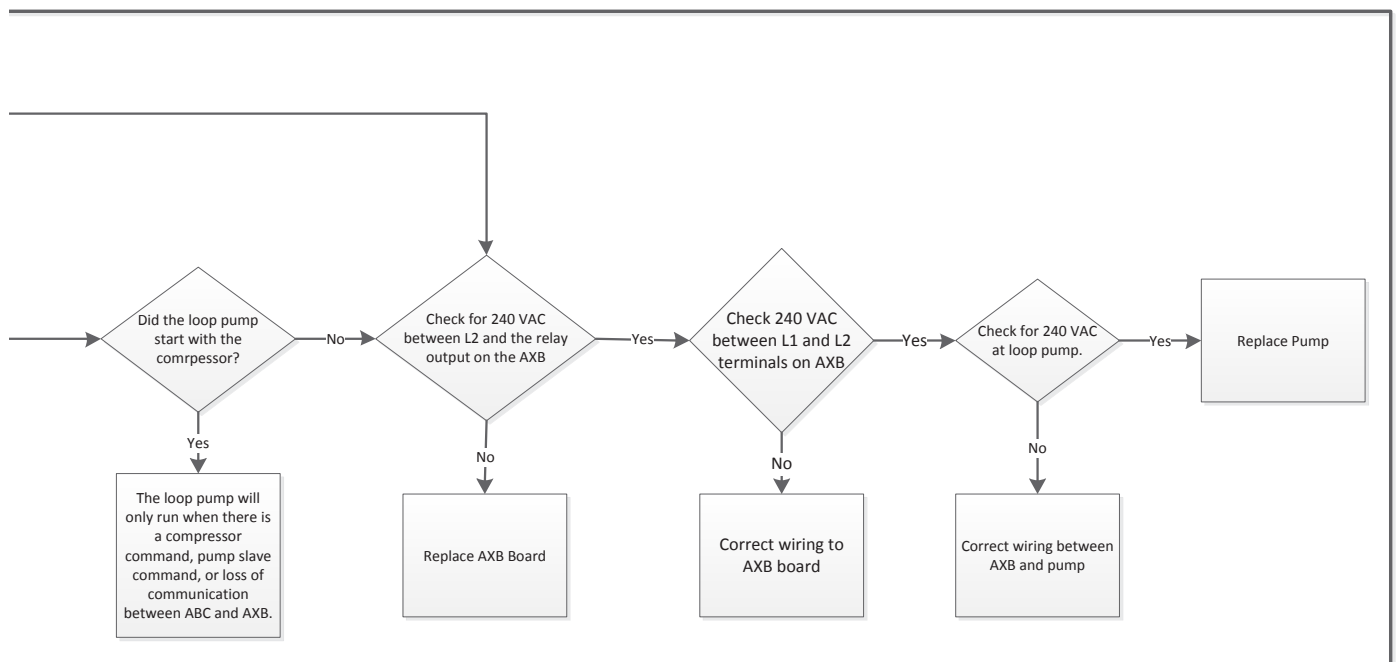

Communicating Thermostat Troubleshooting Guide

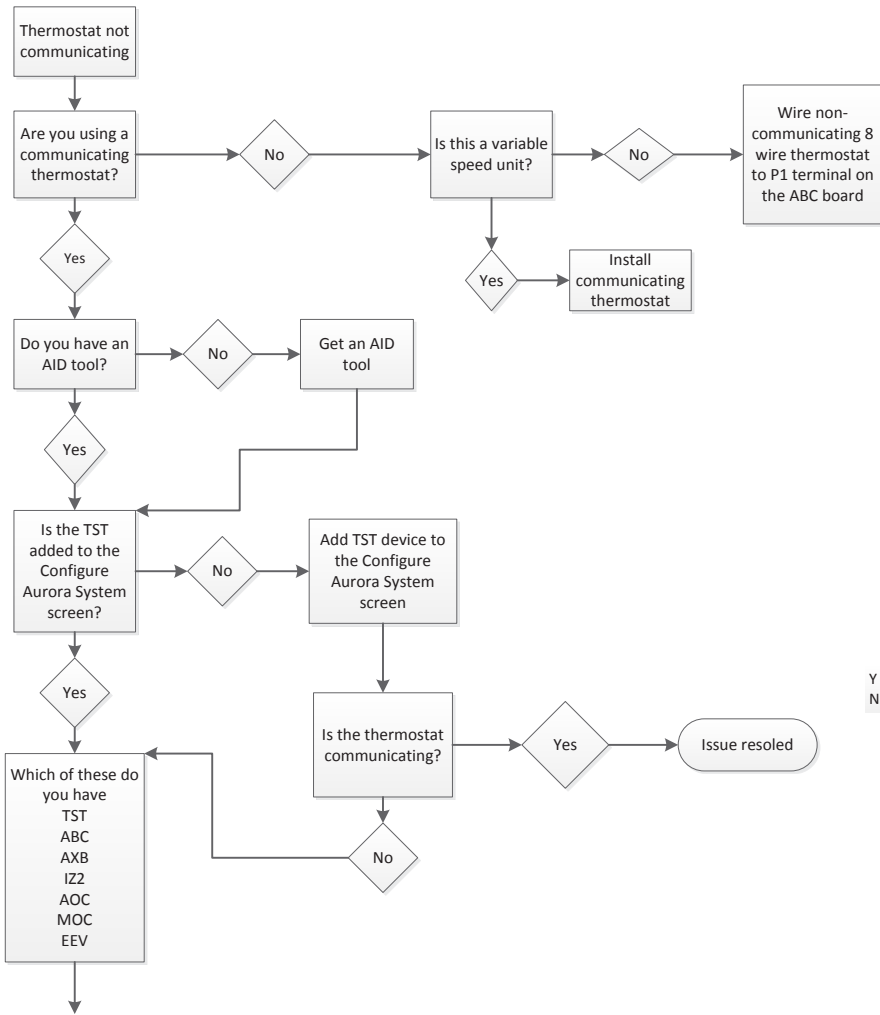

Configure Aurora System Screen

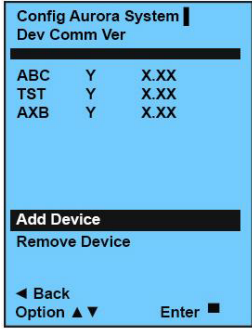

Single and Dual Capacity unit

Y – Active Communication
 N – Device has been found, but communication has failed.

Continue to Next Page

Communicating Thermostat Troubleshooting Guide cont.

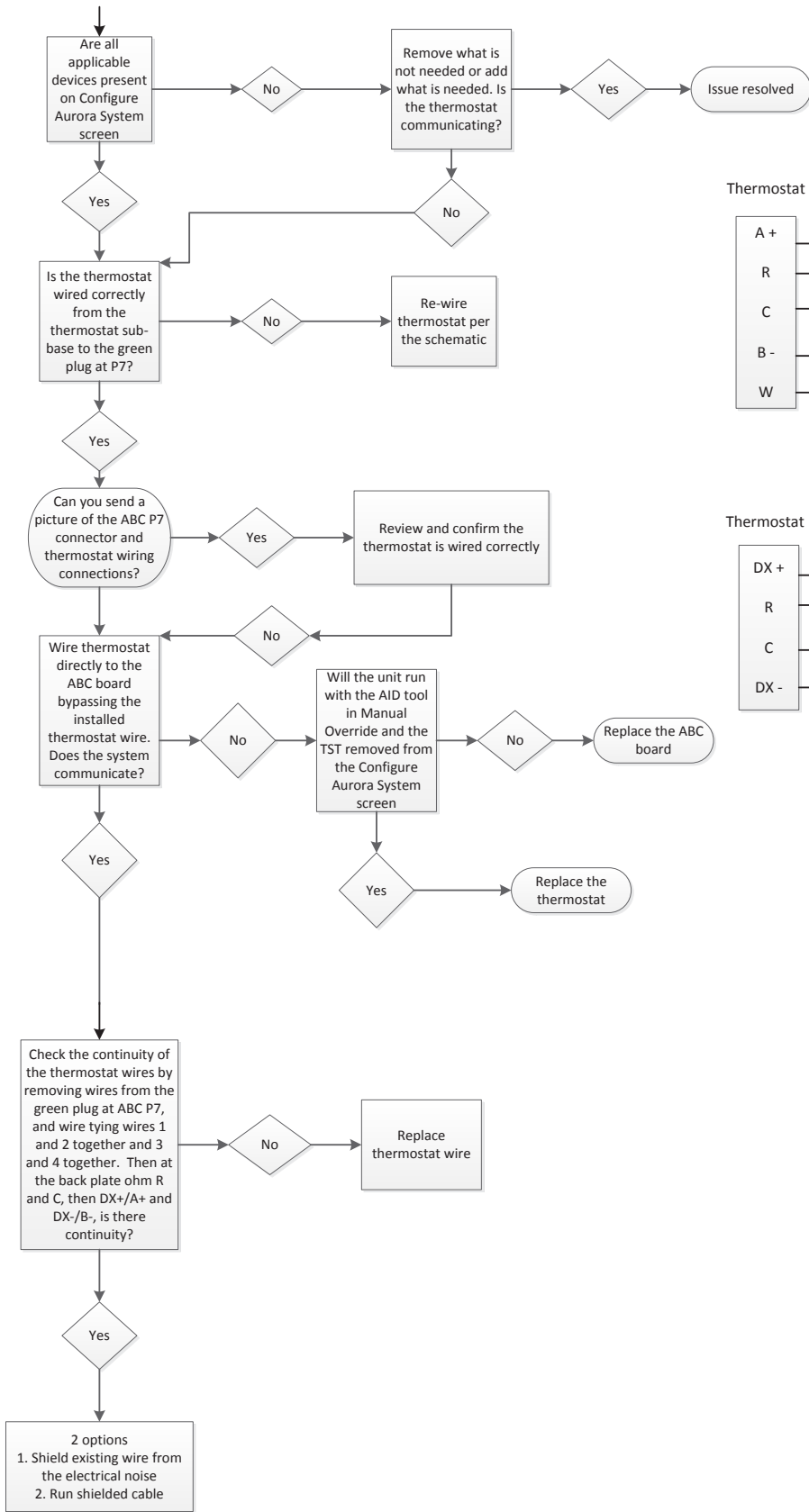

TPCM32U03A*/TPCM32U04A*

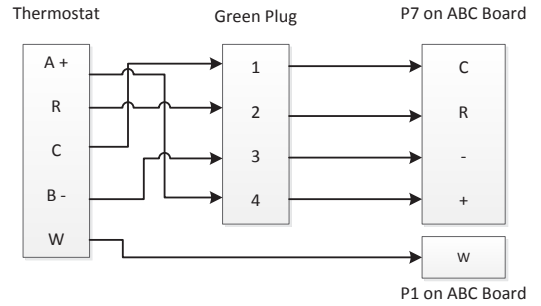

TPCC32U01*

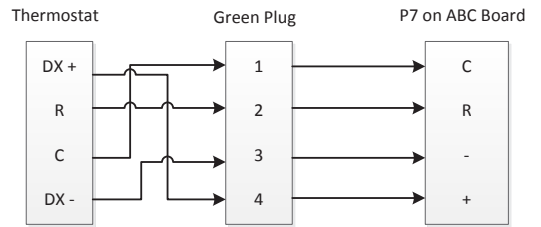

Control Board Signals

To Check for 24VAC between R and C

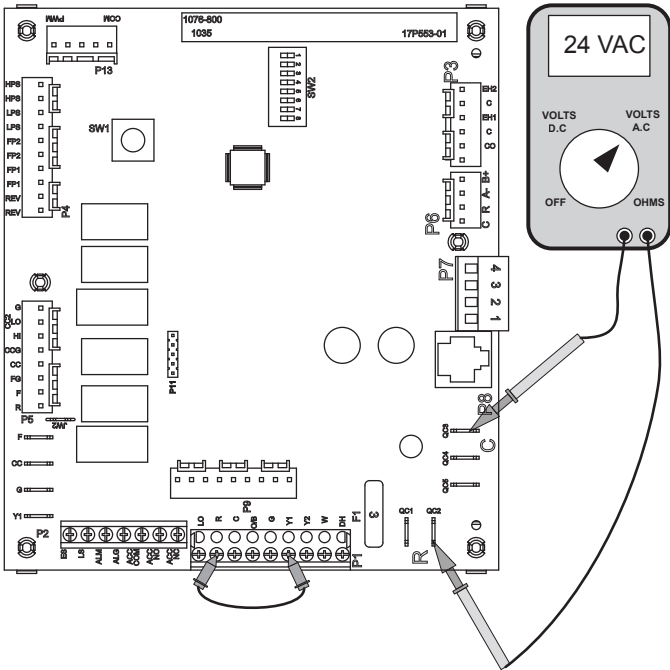

With power applied to the unit connect your Volt meter leads to “R” and “C” on the control board where the yellow and black/white transformer wires connect. The reading should be between 18VAC and 30VAC.

To Check for 24VAC to Compressor Contactor

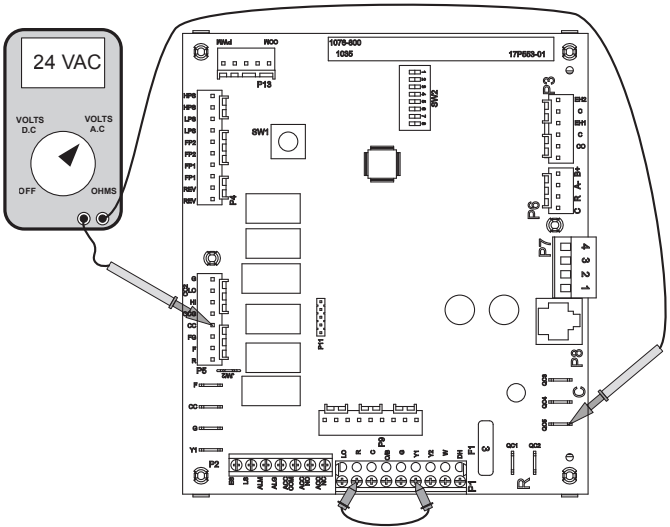

With the AID Tool go to the “Thermostat Inputs” Menu under “Diagnostics” and over-ride the “Y1” input to ON. If an AID Tool is not available remove the P1 connector to disconnect the thermostat from the board and place a jumper wire between “R” and “Y1” as shown. Apply power and put the board into test mode by holding SW1 for 2-5 seconds, the green LED will begin a slow flash. Connect your Volt meter leads to “CC” and “C”. After 1 minute the reading should be

between 18 and 30VAC. If you have a signal and the contactor is not pulled in, check voltage across the contactor coil. If you have voltage across the contractor coil, replace the contactor. If there is no voltage across the contractor coil, verify all wiring between the board and contactor. If you have no voltage between CC and C and the fault LED is not flashing, then replace the board.

To Check Operation of the Reversing Valve Output

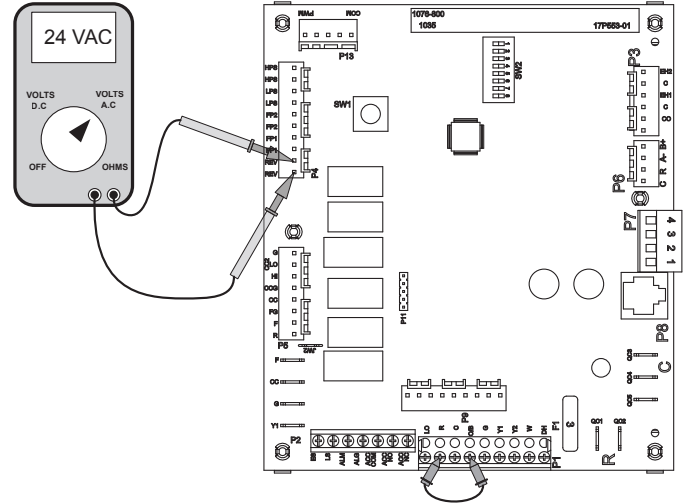

Make sure that SW2-3 is set to “ON”. With the AID Tool go to the “Thermostat Inputs” Menu under “Diagnostics” and over-ride the “O” input to ON. If an AID Tool is not available remove the P1 connector to disconnect the thermostat from the board and place a jumper wire between “R” and “O” as shown. Apply power and put the board into test mode by holding SW1 for 2-5 seconds, the green LED will begin a slow flash. Connect your Volt meter leads to the two “REV” pins on P4. The reading should be between 18 and 30VAC. If you have voltage and the reversing valve is not shifting, check voltage across the coil. If you have voltage across the reversing valve coil, but the valve does not shift the reversing valve coil may be bad. If there is no voltage across the coil, verify all wiring between the board and reversing valve. If no voltage is present on the two REV terminals then replace the board.

Control Board Signals cont.

To Check Operation of the Accessory Relay

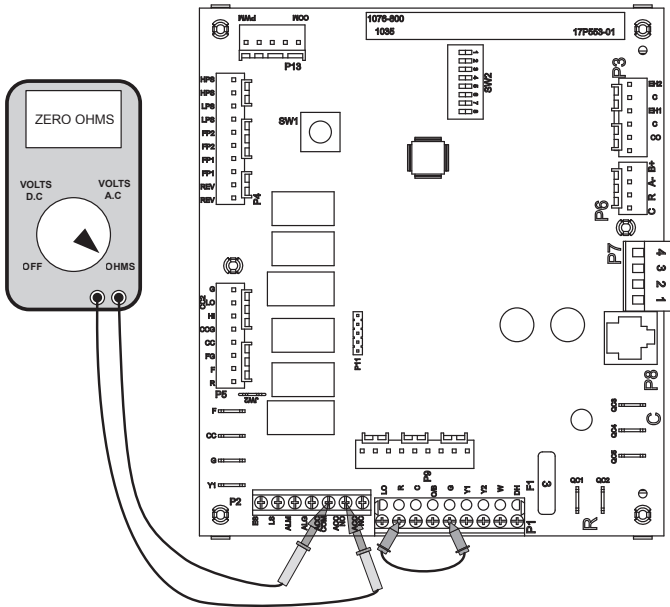

Make sure that SW2-4 and SW2-5 are both set to "ON". With the AID Tool go to the "Thermostat Inputs" Menu under "Diagnostics" and over-ride the "G" input to ON. If an AID Tool is not available remove the P1 connector to disconnect the thermostat from the board and place a jumper wire between "R" and "G" as shown. Apply power and put the board into test mode by holding SW1 for 2-5 seconds, the green LED will begin a slow flash. Connect your Ohm meter leads to the two "ACC COM" and "ACC NO" on P2. A reading of zero ohms indicates that the relay is switching and operating normally. A reading of infinity or open line indicates that the relay did not close and the board should be replaced.

To Bypass the Safety Circuit and Engage the Compressor Contactor

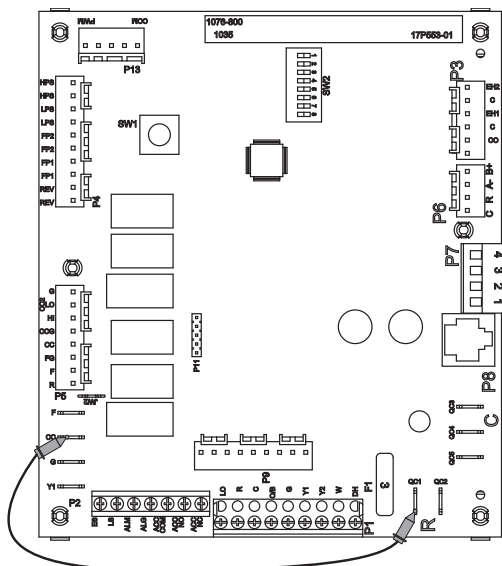

Put gauges on the unit to monitor high/low pressure. Place a jumper between "R" and "CC" as shown. **This will bypass the safety circuit and the compressor will run whether the board is calling for it or not.**

To Check the Freeze Detection Thermistor (AID Tool Required)

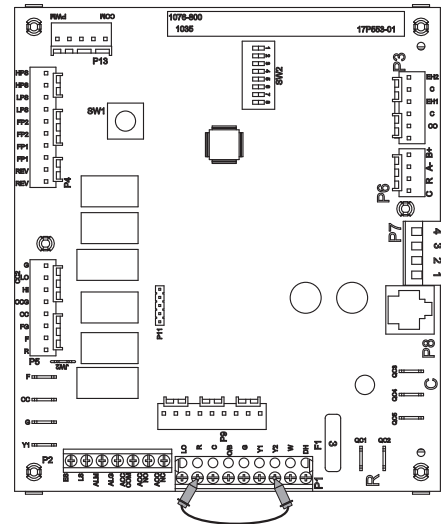

Disconnect the loop pumps so they will not run. Place a thermocouple on the refrigerant line next to the freeze detection thermistor. With the AID Tool go to the "Thermostat Inputs" Menu under "Diagnostics" and over-ride the "Y2" input to ON. If an AID Tool is not available remove the plug on P1 to disconnect the thermostat from the board. Place a jumper on "R" and "Y2" as shown. Apply power and put the board into test mode by holding SW1 for 2-5 seconds, the green LED will begin a slow flash. As the unit runs in second stage heating with the loop pump(s) not working, the lack of water flow will quickly bring down the temperature of the refrigerant line where the freeze detection thermistor is located. Watch the FP1 temperature reading on the AID Tool and compare it with the thermocouple reading. The thermocouple reading and FP1 reading should be within 2 degrees F of each other. If the thermistor is found to be out of calibration, replace the thermistor. Allowing the unit to continue to run will cause a freeze detection fault to occur. Remember, there is a two minute bypass delay and a 30 second recognition delay on the freeze detection input. This means that the compressor will not shut down during the first 2.5 minutes of run time regardless of how low the freeze thermistor reads.

Other items to check when troubleshooting a freeze detection lockout are superheat, water flow through the coaxial heat exchanger, and antifreeze composition. High superheat in heating will lower the refrigerant line temperature where the freeze protection thermistor is located. In this case, check the TXV. Closed loop systems are rated at 3 gpm/ton. If a closed loop system is running at less than 3 gpm/ton, the temperature difference between the refrigerant line and the actual leaving water temperature will be greater and could lead to possible freeze detection lockouts.

Control Board Signals cont.

To Check the Condensate Sensor

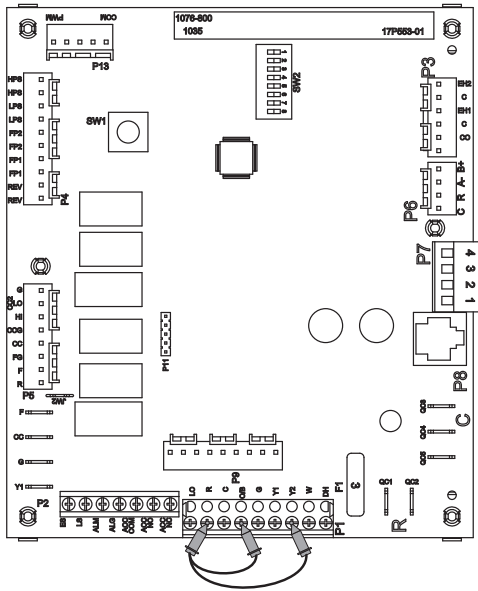

How it works: The condensate sensor is a three part system: a wire, air coil, and water in the drain pan. The wire (spade terminal) and air coil act like a normally open contact and the water acts as the switch. When water in the drain pan fills up and touches the spade terminal, the unit will fault on condensate.

Checking the Sensor: With the AID Tool go to the “Thermostat Inputs” Menu under “Diagnostics” and over-ride the “O” and “Y2” inputs to ON. If an AID Tool is not available remove the P1 connector to disconnect the thermostat from the board and place a jumper wire between “R”, “Y2”, and “O” as shown. Apply power and put the board into test mode by holding SW1 for 2-5 seconds, the green LED will begin a slow flash. Observe the water level in the drain pan. If the unit is locking out on condensate and the drain pan is dry, remove the condensate wire from the drain pan and tape it out of the way. Be careful not to ground the wire out because that will cause the unit to lockout on condensate over flow. If the unit is still locking out, check the brown wire all the way back to the logic board for a short to ground. Remember that the condensate sensor is just a wire looking for a ground. If it touches any metal in the cabinet, the unit will see that as a condensate fault.

If removing the wire from the drain pan stopped the false drain lockouts, put the condensate sensor back in place in the drain pan. Pay close attention to how far the spade terminal sits down in the drain pan. If the terminal is pushed all the way down so that it is touching the bottom of the drain pan, this will cause a condensate lockout if there is any trace of water in the drain pan. If the spade terminal fits loosely in the drain pan, spread the terminal open to make it fit snugly in the drain pan.

To Check the ECM Blower Motor Enable Signal

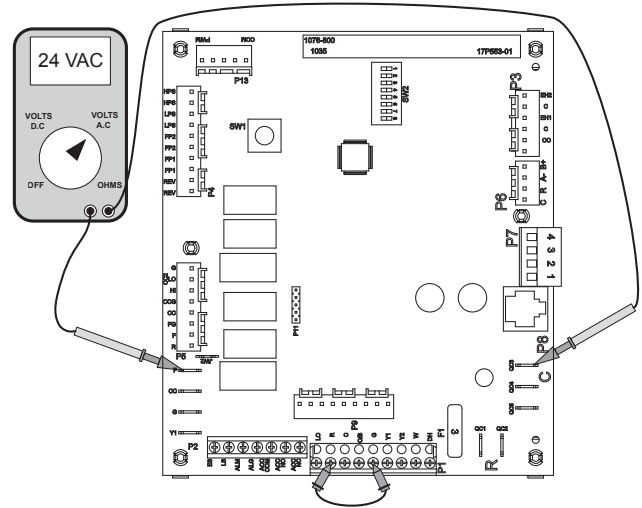

With the AID Tool go to the “Thermostat Inputs” Menu under “Diagnostics” and over-ride the “G” input to ON. If an AID Tool is not available remove the P1 connector to disconnect the thermostat from the board and place a jumper between “R” and “G” as shown. Put the board into test mode by holding SW1 for 2-5 seconds. The blower will come on and run in the “G” speed setting. To check the enable signal to the motor, measure 24VAC between the F and C terminals.

To Check the Electric Heat Outputs

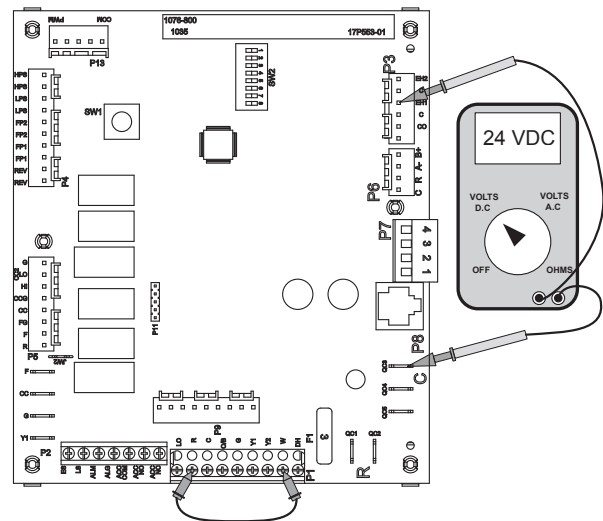

With the AID Tool go to the “Thermostat Inputs” Menu under “Diagnostics” and over-ride the “W” input to ON. If an AID Tool is not available remove the P1 connector to disconnect the thermostat from the board and place a jumper between “R” and “W” as shown. Put the board into test mode by holding SW1 for 2-5 seconds. The blower will come on and run in high speed. 10 seconds later electric heat output 1 (EH1) will be enabled followed by electric heat output 2 (EH2) in 7.5 seconds. Check EH1 by measuring DC volts between “C” and “EH1” and check EH2 by measuring DC volts between “C” and “EH2”.

Jumping the Control Board

Stage 1 Heating

With the AID Tool go to the “Thermostat Inputs” Menu under “Diagnostics” and over-ride the “Y1” input to ON. If an AID Tool is not available remove the P1 connector to disconnect the thermostat from the board. Place a jumper between the “R” and “Y1” terminals as shown.

The blower motor will start in “G” blower speed setting immediately the compressor will start 10 seconds later. If the unit is equipped with an ECM blower motor it will switch to low speed 15 seconds after the Y1 input.

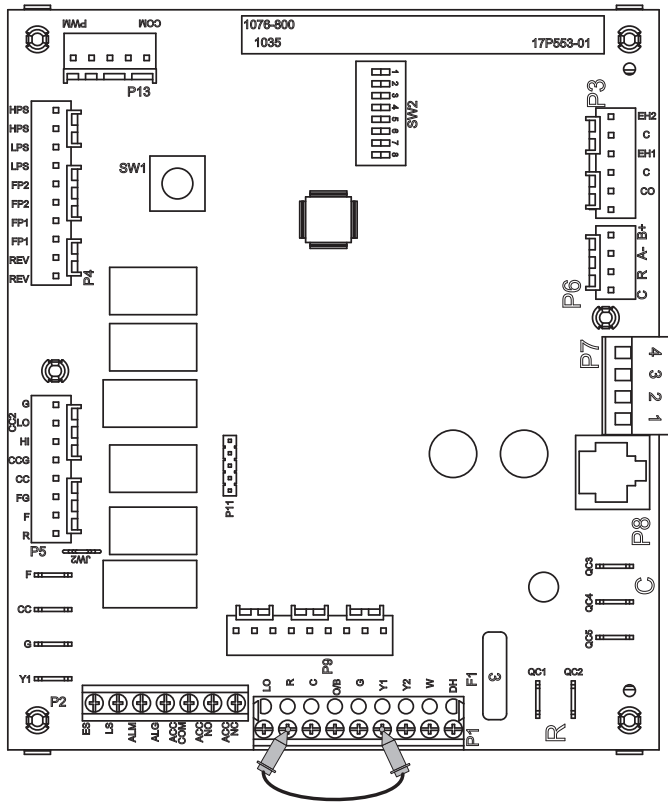

Stage 2 Heating

With the AID Tool go to the “Thermostat Inputs” Menu under “Diagnostics” and over-ride the “Y1” and “Y2” inputs to ON. If an AID Tool is not available remove the P1 connector to disconnect the thermostat from the board. Place a jumper between the R, Y1, and Y2 terminals as shown.

The blower motor will start in “G” blower speed setting immediately the compressor will start 10 seconds later. If the unit is equipped with an ECM blower motor it will switch to low speed 15 seconds after the Y1 input. The compressor will stage to full capacity 20 seconds after the compressor starts, and the blower will change to high speed.

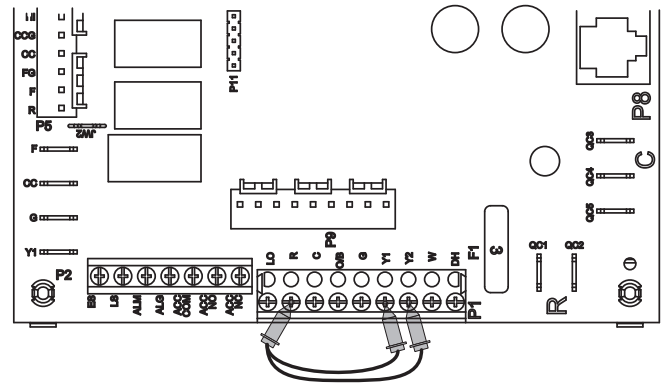

Stage 3 Heating

With the AID Tool go to the “Thermostat Inputs” Menu under “Diagnostics” and over-ride the “Y1”, “Y2”, and “W” inputs to ON. If an AID Tool is not available remove the P1 connector to disconnect the thermostat from the board. Place a jumper between the R, Y1, Y2 and W terminals as shown.

The blower motor will start in “G” blower speed setting immediately the compressor will start 10 seconds later. If the unit is equipped with an ECM blower motor it will switch to low speed 15 seconds after the Y1 input. The compressor will stage to full capacity 20 seconds after the compressor starts, and the blower will change to high speed. The first stage of resistance heat is energized and with continuous third stage demand the second stage of resistance heat will engage in 5 minutes.

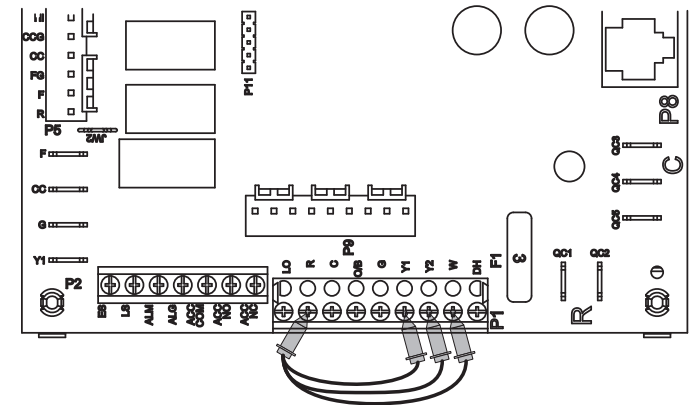

Jumping the Control Board cont.

Emergency Heat

With the AID Tool go to the “Thermostat Inputs” Menu under “Diagnostics” and over-ride the “W” input to ON. If an AID Tool is not available remove the P1 connector to disconnect the thermostat from the board. Place a jumper between the “R” and “W” terminals as shown.

The blower will start on high speed and after 20 seconds the first stage of resistance heat is energized. Continuing demand will engage the second stage after 2 minutes.

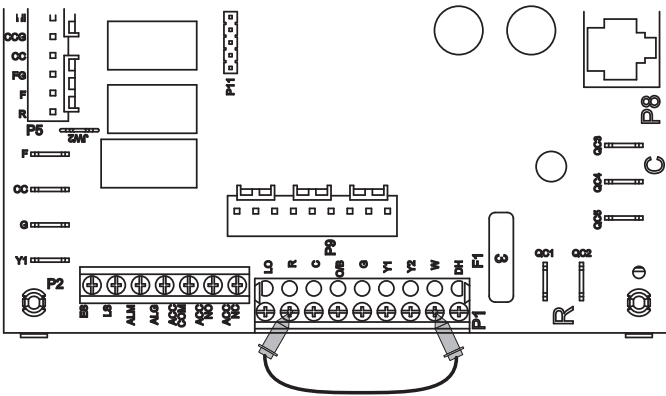

Blower Only

With the AID Tool go to the “Thermostat Inputs” Menu under “Diagnostics” and over-ride the “G” input to ON. If an AID Tool is not available remove the P1 connector to disconnect the thermostat from the board. Place a jumper between the “R” and “G” terminals as shown.

The blower will start on the “G” speed setting. Also, regardless of blower speed setting, the blower will remain on for 30 seconds at the end of each heating, cooling, emergency heat, or reheat cycle.

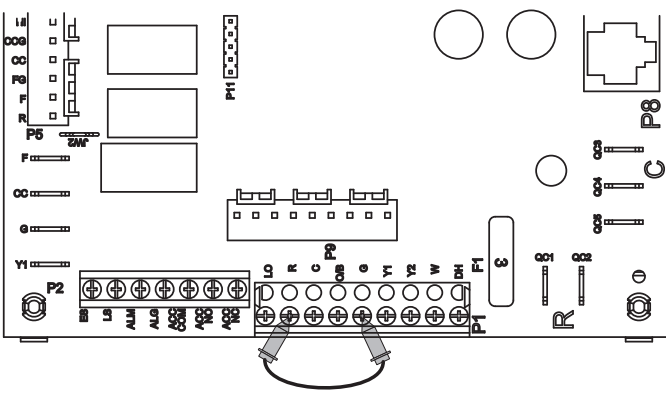

Stage 1 Cooling

With the AID Tool go to the “Thermostat Inputs” Menu under “Diagnostics” and over-ride the “Y1” and “O” inputs to ON. If an AID Tool is not available remove the P1 connector to disconnect the thermostat from the board. Place a jumper between the R, O, and Y1 terminals as shown.

The blower motor will start in “G” blower speed setting immediately, the compressor will start 10 seconds later. If the unit is equipped with an ECM blower motor it will switch to low speed 15 seconds after the Y1 input.

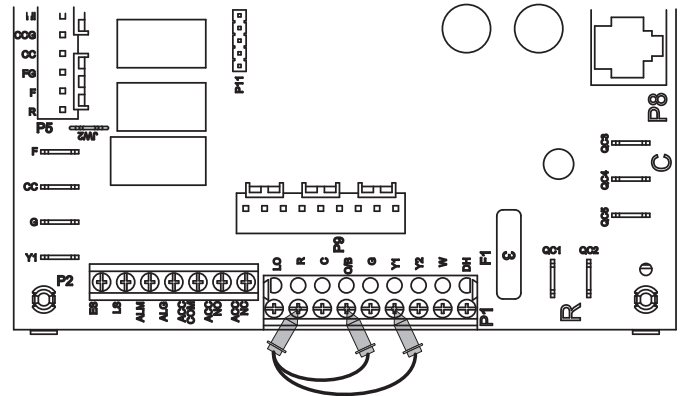

Stage 2 Cooling

With the AID Tool go to the “Thermostat Inputs” Menu under “Diagnostics” and over-ride the “Y1”, “Y2”, and “O” inputs to ON. If an AID Tool is not available remove the P1 connector to disconnect the thermostat from the board. Place a jumper between the R, O, Y1, and Y2 terminals as shown.

The blower motor will start in “G” blower speed setting immediately the compressor will start 10 seconds later. If the unit is equipped with an ECM blower motor it will switch to low speed 15 seconds after the Y1 input. The compressor will stage to full capacity 20 seconds after the compressor starts, and the blower will change to high speed.

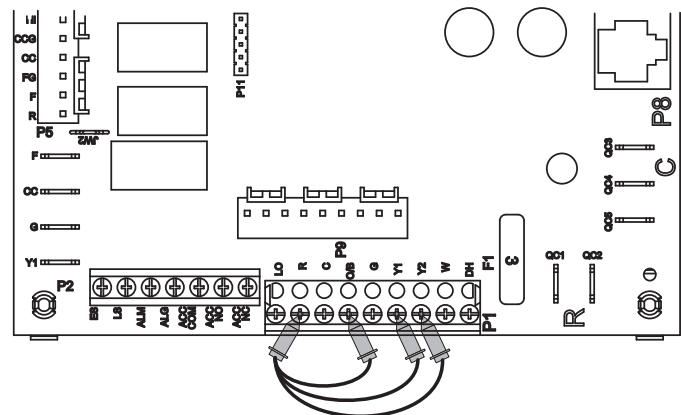

Jumping the Control Board cont.

Reheat Mode

With the AID Tool go to the “Thermostat Inputs” Menu under “Diagnostics” and over-ride the “DH” input to ON. If an AID Tool is not available remove the P1 connector to disconnect the thermostat from the board. Place a jumper between the R and DH terminals as shown.

The blower motor will start in “G” blower speed setting immediately the compressor will start 10 seconds later. If the unit is equipped with an ECM blower motor it will switch to low speed 15 seconds after the DH input. 20 seconds after the DH input is received the compressor will switch to full capacity and the blower motor will switch to dehumidification high speed. 30 seconds after the compressor starts the alarm/reheat output will energize.

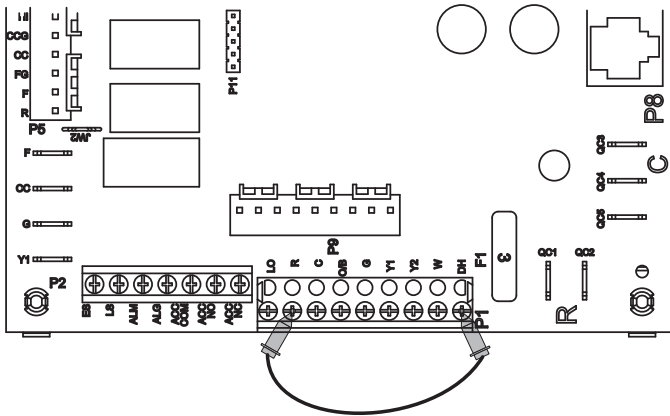

Reference Calculations

Heating Calculations:	Cooling Calculations:
$LWT = EWT - \frac{HE}{gpm \times 500}$	$LWT = EWT + \frac{HR}{gpm \times 500}$
$LAT = EAT + \frac{HC}{cfm \times 1.08}$	$LAT(DB) = EAT(DB) - \frac{SC}{cfm \times 1.08}$
$TH = HC + HWC$	$LC = TC - SC$
	$S/T = \frac{SC}{TC}$

Legend and Notes

ABBREVIATIONS AND DEFINITIONS:

cfm	= airflow, cubic feet/minute	HE	= total heat of extraction, MBtu/h
EWT	= entering water temperature, Fahrenheit	HWC	= hot water generator capacity, MBtu/h
gpm	= water flow in gallons/minute	EER	= Energy Efficient Ratio
WPD	= water pressure drop, PSI and feet of water		= BTU output/Watt input
EAT	= entering air temperature, Fahrenheit (dry bulb/wet bulb)	COP	= Coefficient of Performance
HC	= air heating capacity, MBtu/h		= BTU output/BTU input
TC	= total cooling capacity, MBtu/h	LWT	= leaving water temperature, °F
SC	= sensible cooling capacity, MBtu/h	LAT	= leaving air temperature, °F
KW	= total power unit input, kilowatts	TH	= total heating capacity, MBtu/h
HR	= total heat of rejection, MBtu/h	LC	= latent cooling capacity, MBtu/h
		S/T	= sensible to total cooling ratio

Heat of Extraction / Rejection Dual Capacity

Model		GPM	Heat of Extraction (kBtuh)				Heat of Rejection (kBtuh)				
			30°F	50°F	70°F	90°F	30°F	50°F	70°F	90°F	110°F
018	Part Load	2.0		10.1	13.0	15.2		16.7	17.2	16.4	
		3.0	7.5	10.6	13.1	16.2	16.8	16.9	17.3	16.6	15.6
		3.0	7.7	10.9	14.1	16.8	16.9	17.0	17.4	16.7	15.7
	Full Load	4.0		13.8	18.1	20.7		22.8	22.5	21.9	
		5.0	10.9	14.4	18.4	22.1	23.2	23.0	22.6	22.4	21.0
		6.0	11.1	14.8	19.0	22.9	23.4	23.2	22.8	22.5	21.1
024	Part Load	3.0		11.9	15.4	17.5		21.3	21.2	20.1	
		5.0	9.4	12.4	15.6	18.7	20.7	21.6	21.3	20.5	20.0
		7.0	9.6	12.7	16.1	19.4	20.8	21.7	21.6	20.6	20.1
	Full Load	4.0		16.5	18.0	23.6		29.8	29.6	28.7	
		6.0	13.4	17.2	21.4	25.2	28.2	29.9	29.7	29.1	27.4
		8.0	13.7	17.6	22.1	26.1	28.4	30.1	29.8	29.3	27.5
030	Part Load	5.0		17.0	21.7	27.3		30.2	29.0	27.5	
		6.0	11.6	17.7	22.3	29.1	27.0	30.6	29.2	28.1	26.3
		7.0	11.9	18.2	22.4	30.1	27.2	30.9	29.3	28.2	26.4
	Full Load	6.0		23.6	32.3	38.6		41.2	39.8	37.4	
		7.0	18.0	24.6	32.8	41.1	38.8	41.6	40.1	38.1	36.8
		8.0	18.4	25.2	33.3	42.6	39.1	41.9	43.1	38.3	37.0
036	Part Load	4.0		17.6	21.2	30.8		35.5	34.0	31.8	
		6.0	14.6	18.4	22.3	32.8	31.6	35.9	34.1	32.4	30.9
		8.0	14.9	18.9	22.9	34.0	31.9	36.2	34.4	32.6	31.0
	Full Load	5.0		27.0	34.5	41.8		49.3	46.5	44.1	
		7.0	21.5	28.2	36.1	44.6	37.0	49.9	46.7	45.0	42.9
		9.0	22.0	29.9	37.2	46.2	37.3	50.2	47.1	45.2	43.1
042	Part Load	4.0		22.2	29.3	37.8		39.2	38.2	37.7	
		6.0	16.3	23.2	31.4	40.0	34.8	39.9	38.6	37.8	33.6
		8.0	17.6	24.4	32.3	41.0	35.1	40.5	39.1	38.3	33.9
	Full Load	5.0		32.6	40.0	44.0		52.4	54.7	52.0	
		8.0	25.5	34.0	43.6	47.0	45.2	52.9	55.2	53.1	50.4
		11.0	26.1	34.9	45.0	48.6	45.6	53.3	55.3	53.5	50.6
048	Part Load	5.0		26.0	32.6	43.4		44.8	45.5	43.6	
		8.0	18.0	27.2	36.3	46.1	37.3	45.4	45.6	42.7	40.3
		11.0	19.5	28.6	37.3	46.2	37.6	46.0	46.2	44.2	40.7
	Full Load	6.0		36.4	45.0	51.1		60.1	59.5	55.9	
		9.0	27.7	38.0	47.7	54.5	50.9	60.7	59.6	56.9	53.1
		12.0	28.4	39.0	49.2	56.8	51.2	61.1	59.9	57.2	53.3
060	Part Load	6.0		31.2	43.0	54.9		55.1	53.0	51.2	
		10.0	21.2	32.7	45.1	57.8	50.5	55.5	53.5	51.4	48.1
		14.0	23.0	34.4	46.3	58.3	50.9	56.3	54.1	51.8	48.5
	Full Load	8.0		42.4	59.0	73.0		70.2	75.2	72.4	
		12.0	27.0	44.3	63.7	77.6	60.9	77.9	75.9	72.5	70.0
		16.0	29.2	46.7	65.4	77.8	61.3	78.9	76.2	73.3	70.7
072	Part Load	10.0		37.9	52.5	65.4		64.5	65.8	63.4	
		13.0	26.4	39.6	54.1	69.5	56.8	69.2	66.2	63.6	61.0
		16.0	28.6	41.7	55.5	70.1	57.3	70.1	66.6	64.3	61.6
	Full Load	12.0		52.6	71.0	83.3		88.5	89.5	85.8	
		15.0	39.6	54.9	72.5	88.9	73.7	89.2	89.9	87.4	83.6
		18.0	40.6	56.3	74.9	92.1	74.1	89.8	90.1	87.7	83.9

Note: operation not recommended in shaded areas.

Preventative Maintenance

Water Coil Maintenance

1. Keep all air out of the water. An open loop system should be checked to ensure that the well head is not allowing air to infiltrate the water line. Lines should always be airtight.
2. Keep the system under pressure at all times. It is recommended in open loop systems that the water control valve be placed in the discharge line to prevent loss of pressure during off cycles. Closed loop systems must have positive static pressure.

NOTE: On open loop systems, if the installation is in an area with a known high mineral content (125 PPM or greater) in the water, it is best to establish with the owner a periodic maintenance schedule so the coil can be checked regularly. Should periodic coil cleaning be necessary, use standard coil cleaning procedures which are compatible with either the cupronickel or copper water lines. Generally, the more water flowing through the unit the less chance for scaling.

Other Maintenance

Filters

Filters must be clean to obtain maximum performance. They should be inspected monthly under normal operating conditions and be replaced when necessary. Units should never be operated without a filter.

Condensate Drain

In areas where airborne bacteria produce a slime in the drain pan, it may be necessary to treat chemically to minimize the problem. The condensate drain can pick up lint and dirt, especially with dirty filters. Inspect twice a year to avoid the possibility of overflow.

Blower Motors

Blower motors are equipped with sealed ball bearings and require no periodic oiling.

Hot Water Generator Coil

See Water Coil Maintenance section above.

Air Coil

The air coil must be cleaned to obtain maximum performance. Check once a year under normal operating conditions and, if dirty, brush or vacuum (with a brush attachment) clean. Care must be taken not to damage the aluminum fins while cleaning.



CAUTION: Fin edges are sharp.

Replacement Procedures

Obtaining Parts

When ordering service or replacement parts, refer to the model number and serial number of the unit as stamped on the serial plate attached to the unit. If replacement parts are required, mention the date of installation of the unit and the date of failure, along with an explanation of the malfunctions and a description of the replacement parts required.

In-Warranty Material Return

Material may not be returned except by permission of authorized warranty personnel. Contact your local distributor for warranty return authorization and assistance.

Troubleshooting

Should a major problem develop, refer to the following information for possible causes and corrective steps.

If compressor won't run:

1. The fuse may be open or the circuit breaker is tripped. Check electrical circuits and motor windings for shorts or grounds. Investigate for possible overloading. Replace fuse or reset circuit breakers after fault is corrected.
2. Supply voltage may be too low. Check it with a volt meter.
3. Control system may be faulty. Check control for correct wiring of thermostat or aquastat and check the 24 volt transformer for proper voltage.
4. Wires may be loose or broken. Replace or tighten.
5. The low pressure switch may have tripped due to one or more of the following:
 - a) Heating
 - 1) Plugged heat exchanger on source side
 - 2) Water flow source side - (Low)
 - 3) Water too cold source side
 - 4) Low refrigerant
 - b) Cooling
 - 1) Plugged heat exchanger on load side
 - 2) Water flow load side - (Low)
 - 3) Water too cold load side
 - 4) Low refrigerant
6. The high pressure switch may have tripped due to one or more of the following:
 - a) Heating
 - 1) Plugged heat exchanger on load side
 - 2) Low water flow load side
 - 3) Water too warm load side
 - b) Cooling
 - 1) Plugged heat exchanger on source side
 - 2) Low water flow on source side
 - 3) Water too warm source side
7. The compressor overload protection may be open.
8. The internal winding of the compressor motor may be grounded to the compressor shell. If so, replace the compressor.
9. The compressor winding may be open or shorted. Disconnect power. Check continuity with ohm meter. If the winding is open, replace the compressor.

If sufficient cooling or heating is not obtained:

1. Check control for improper location or setting.
2. Check for restriction in water flow.
3. Check refrigerant subcooling and superheat for proper refrigerant charge and expansion valve operation.
4. The reversing valve may be defective and creating a bypass of refrigerant. If the unit will not heat, check the reversing valve coil.

If the unit operation is noisy:

1. Check compressor for loosened mounting bolts. Make sure compressor is floating free on its isolator mounts. Check for tubing contact with the compressor or other surfaces. Readjust it by bending slightly.
2. Check screws on all panels.
3. Check for chattering or humming in the contactor or relays due to low voltage or a defective holding coil. Replace the component.
4. Check for proper installation of vibration absorbing material under the unit.
5. Check for abnormally high discharge pressures.
6. Compressor rotation incorrect

Aurora® Control System

NOTE: Refer to the Aurora® Base Control Application and Troubleshooting Guide and the Instruction Guide: Aurora® Interface and Diagnostics (AID) Tool for additional information.

To check the unit control board for proper operation:

1. Disconnect thermostat wires at the control board.
2. Jumper the desired test input (Y1, Y2, W, O or G) to the R terminal to simulate a thermostat signal.
3. If control functions properly:
 - Check for thermostat and field control wiring (use the diagnostic inputs mode).
4. If control responds improperly:
 - Ensure that component being controlled is functioning (compressor, blower, reversing valve, etc.).
 - Ensure that wiring from control to the component is functioning (refer to the LED Definition table below and use the diagnostic outputs mode).
 - If steps above check properly, replace unit control.

Refrigerant Systems

To maintain sealed circuit integrity, do not install service gauges unless unit operation appears abnormal. Compare the change in temperature on the air side as well as the water side to the Operating Parameters tables. If the unit's performance is not within the ranges listed, and the airflow and water flow are known to be correct, gauges should then be installed and superheat and subcooling numbers calculated. If superheat and subcooling are outside recommended ranges, an adjustment to the refrigerant charge may be necessary.

NOTE: Refrigerant tests must be made with hot water generator turned "OFF". Verify that air and water flow rates are at proper levels before servicing the refrigerant circuit.

Troubleshooting Checklist

Company Name: _____ Company Phone No: _____
 Technician Name: _____ Date: _____
 Model No: _____ Serial No: _____
 Owner's Name: _____ Open or Closed Loop: _____
 Installation Address: _____ Installation Date: _____

Check One

Start up/Check-out for new installation Troubleshooting Problem: _____

1. FLOW RATE IN GPM (COAXIAL HEAT EXCHANGER)

Water In Pressure: a. _____ PSI
 Water Out Pressure: b. _____ PSI
 Pressure Drop = a - b c. _____ PSI
 Convert Pressure Drop to Flow Rate
 (refer to *Pressure Drop* table) d. _____ GPM

2. TEMPERATURE RISE OR DROP ACROSS COAXIAL HEAT EXCHANGER

	COOLING	HEATING
Water In Temperature:	e. _____ °F	e. _____ °F
Water Out Temperature:	f. _____ °F	f. _____ °F
Temperature Difference:	g. _____ °F	g. _____ °F

3. TEMPERATURE RISE OR DROP ACROSS AIR COIL

	COOLING	HEATING
Air In Temperature:	h. _____ °F	h. _____ °F
Air Out Temperature:	i. _____ °F	i. _____ °F
Temperature Difference:	j. _____ °F	j. _____ °F

4. HEAT OF REJECTION (HR) / HEAT OF EXTRACTION (HE) CALCULATION

HR or HE = Flow Rate x Temperature Difference x Brine Factor*
 d. (above) x g. (above) x 485 for Methanol or Environol, 500 for water*
 Heat of Extraction (Heating Mode) = _____ btu/hr
 Heat of Rejection (Cooling Mode) = _____ btu/hr
 Compare results to Capacity Data Tables

Note: Steps 5 through 8 need only be completed if a problem is suspected

5. WATTS

	COOLING	HEATING
Volts:	m. _____ VOLTS	m. _____ VOLTS
Total Amps (Comp. + Fan):	n. _____ AMPS	n. _____ AMPS
Watts = m. x n. x 0.85	o. _____ WATTS	o. _____ WATTS

6. CAPACITY

Cooling Capacity = HR. - (o. x 3.413) p. _____ btu/hr
 Heating Capacity = HE. + (o. x 3.413) p. _____ btu/hr

7. EFFICIENCY

Cooling EER = p. / o. q. _____ EER
 Heating COP = p. / (o. x 3.413) q. _____ COP

8. SUPERHEAT (S.H.) / SUBCOOLING (S.C.)

	COOLING	HEATING
Suction Pressure:	r. _____ PSI	r. _____ PSI
Suction Saturation Temperature:	s. _____ °F	s. _____ °F
Suction Line Temperature:	t. _____ °F	t. _____ °F
Superheat = t. - s.	u. _____ °F	u. _____ °F
Head Pressure:	v. _____ PSI	v. _____ PSI
High Pressure Saturation Temp.:	w. _____ °F	w. _____ °F
Liquid Line Temperature*:	x. _____ °F	x. _____ °F
Subcooling = w. - x.	y. _____ °F	y. _____ °F

* Note: Liquid line is between the coaxial heat exchanger and the expansion valve in the cooling mode; between the air coil and the expansion valve in the heating mode.

Troubleshooting Checklist

Startup/Troubleshooting Form

Dealer: _____
 Phone #: _____ Date: _____
 Problem: _____
 Model #: _____
 Serial #: _____

Controls Info:
 ABC Version: _____
 AXB Version: _____
 IZ2 Version: _____
 T-Stat Version: _____
 Installed Sensors: _____

COOLING CYCLE ANALYSIS

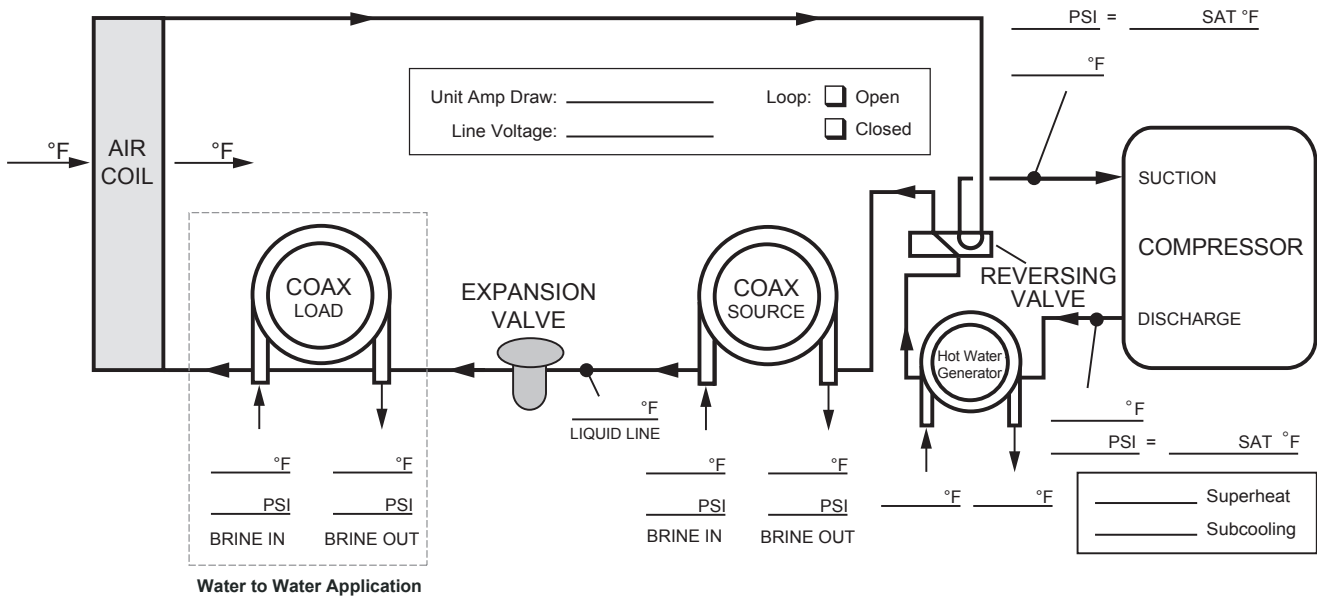

$$\text{Heat of Extraction/Rejection} = \text{gpm} \times 500 \text{ (485 for water/antifreeze)} \times \Delta T$$

Note: DO NOT hook up pressure gauges unless there appears to be a performance problem.

HEATING CYCLE ANALYSIS

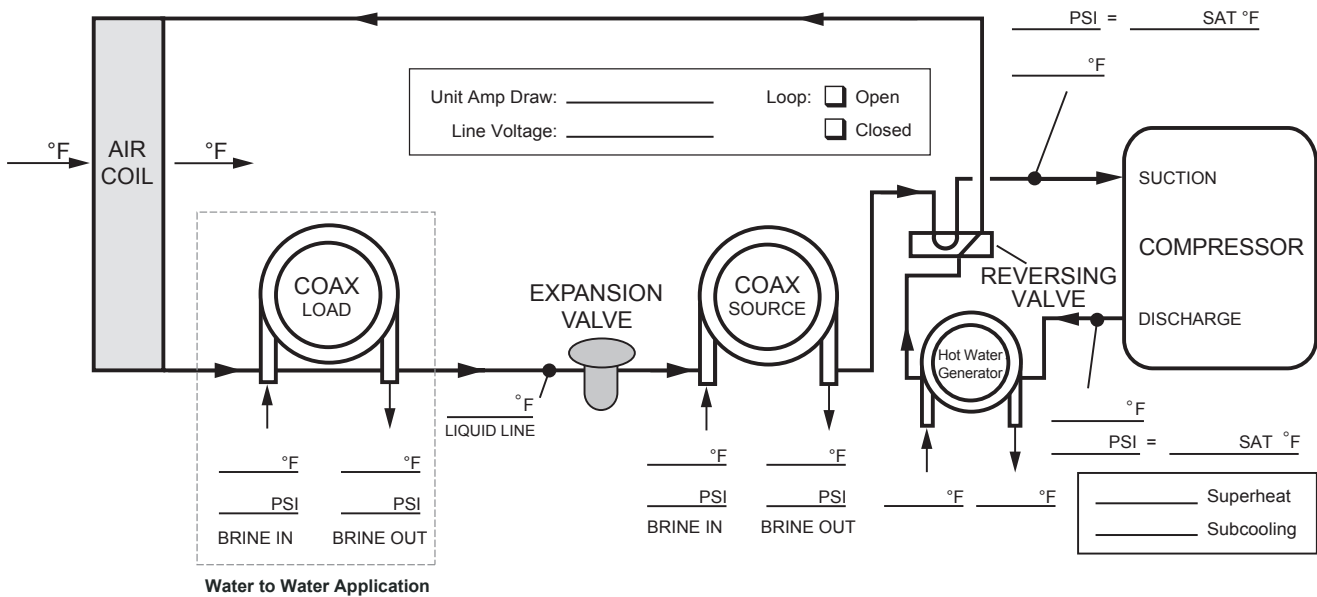

Decommissioning

Before carrying out this procedure, it is essential that the technician is completely familiar with the equipment and all its detail. It is recommended good practice that all refrigerants are recovered safely. Prior to the task being carried out, an oil and refrigerant sample shall be taken in case analysis is required prior to re-use of recovered refrigerant. It is essential that electrical power is available before the task is commenced.

1. Become familiar with the equipment and its operation.
2. Isolate system electrically.
3. Before attempting the procedure, ensure that:
 - mechanical handling equipment is available, if required, for handling refrigerant cylinders;
 - all personal protective equipment is available and being used correctly;
 - the recovery process is supervised at all times by a competent person;
 - recovery equipment and cylinders conform to the appropriate standards.
4. Pump down refrigerant system, if possible.
5. If a vacuum is not possible, make a manifold so that refrigerant can be removed from various parts of the system.
6. Make sure that cylinder is situated on the scales before recovery takes place.
7. Start the recovery machine and operate in accordance with instructions.
8. Do not overfill cylinders (no more than 80 % volume liquid charge).
9. Do not exceed the maximum working pressure of the cylinder, even temporarily.
10. When the cylinders have been filled correctly and the process completed, make sure that the cylinders and the equipment are removed from site promptly and all isolation valves on the equipment are closed off.
11. Recovered refrigerant shall not be charged into another REFRIGERATING SYSTEM unless it has been cleaned and checked.

Decommissioning - Unit Labeling Requirements

Equipment shall be labelled stating that it has been de-commissioned and emptied of refrigerant. The label shall be dated and signed. For appliances containing FLAMMABLE REFRIGERANTS, ensure that there are labels on the equipment stating the equipment contains FLAMMABLE REFRIGERANT.

Refrigerant Recovery

When removing refrigerant from a system, either for servicing or decommissioning, it is recommended good practice that all refrigerants are removed safely.

When transferring refrigerant into cylinders, ensure that only appropriate refrigerant recovery cylinders are employed. Ensure that the correct number of cylinders for holding the total system charge is available. All cylinders to be used are designated for the recovered refrigerant and labelled for that refrigerant (i.e. special cylinders for the recovery of refrigerant). Cylinders shall be complete with pressure-relief valve and associated shut-off valves in good working order. Empty recovery cylinders are evacuated and, if possible, cooled before recovery occurs.

The recovery equipment shall be in good working order with a set of instructions concerning the equipment that is at hand and shall be suitable for the recovery of the flammable refrigerant. If in doubt, the manufacturer should be consulted. In addition, a set of calibrated weighing scales shall be available and in good working order. Hoses shall be complete with leak-free disconnect couplings and in good condition.

The recovered refrigerant shall be processed according to local legislation in the correct recovery cylinder, and the relevant waste transfer note arranged. Do not mix refrigerants in recovery units and especially not in cylinders.

If compressors or compressor oils are to be removed, ensure that they have been evacuated to an acceptable level to make certain that flammable refrigerant does not remain within the lubricant. The compressor body shall not be heated by an open flame or other ignition sources to accelerate this process. When oil is drained from a system, it shall be carried out safely.

Refrigerant Removal and Evacuation

When breaking into the refrigerant circuit to make repairs – or for any other purpose conventional procedures shall be used. However, for flammable refrigerants it is important that best practice be followed, since flammability is a consideration. The following procedure shall be adhered to:

- safely remove refrigerant following local and national regulations;
- evacuate;
- purge the circuit with inert gas (optional for A2L);
- evacuate (optional for A2L);
- continuously flush or purge with inert gas when using flame to open circuit; and
- open the circuit.

The refrigerant charge shall be recovered into the correct recovery cylinders if venting is not allowed by local and national codes. For appliances containing flammable refrigerants, the system shall be purged with oxygen-free nitrogen to render the appliance safe for flammable refrigerants.

This process might need to be repeated several times. Compressed air or oxygen shall not be used for purging refrigerant systems. For appliances containing flammable refrigerants, refrigerants purging shall be achieved by breaking the vacuum in the system with oxygen-free nitrogen and continuing to fill until the working pressure is achieved, then venting to atmosphere, and finally pulling down to a vacuum (optional for A2L). This process shall be repeated until no refrigerant is within the system (optional for A2L). When the final oxygen-free nitrogen charge is used, the system shall be vented down to atmospheric pressure to enable work to take place. The outlet for the vacuum pump shall not be close to any potential ignition sources, and ventilation shall be available.

Charging procedures

In addition to conventional charging procedures, the following requirements shall be followed.

- Ensure that contamination of different refrigerants does not occur when using charging equipment.
- Hoses or lines shall be as short as possible to minimise the amount of refrigerant contained in them.
- Cylinders shall be kept in an appropriate position according to the instructions.
- Ensure that the REFRIGERATING SYSTEM is earthed prior to charging the system with refrigerant.
- Label the system when charging is complete (if not already).
- Extreme care shall be taken not to overfill the REFRIGERATING SYSTEM.

Prior to recharging the system, it shall be pressure-tested with the appropriate purging gas. The system shall be leak-tested on completion of charging but prior to commissioning. A follow up leak test shall be carried out prior to leaving the site.

Revision Guide

Pages:	Description:	Date:	By:
All	Document Creation	14 Feb 2024	SW
7-8	Added AHRI Data	08 Jan 2025	SW
10	Update Physical Data	08 Jan 2025	SW
4	Added Freeze Protection Warning	10 Mar 2025	SW
39-47	Notation on UPC as optional accessory on certain models	10 April 2025	SW
20-21	Added Neutral Wire Warning	7 May 2025	SW
Misc	Updated UPC2	1 Oct 2025	SW
18-19	Updated Electrical Data	23 Oct 2025	SW
18-21	Updated Electrical Data	16 March 2026	SW
18, 25	Updated Electrical Data, Blower Performance	13 April 2026	SW
Misc	Part Number Rev B	13 April 2026	SW
6	Update Nomenclature	14 April 2026	SW
9-10	Update Physical Data	22 April 2026	SW



Product: **Aston® Series Compact**
Type: Geothermal/Water Source Heat Pump
Size: 0.75-6 Ton Single Speed
2-6 Ton Dual Capacity

Document Type: Operation & Maintenance Manual
Part Number: OMV5-0006GB
Release Date: 04/26