

# ARBOR SERIES

## COMMERCIAL

Water Source/Geothermal Heat Pump

- R-410A Refrigerant
- Commercial 0.75-6 Ton

Installation Information

Water Piping Connections

Hot Water Connections

Electrical

Startup Procedures

Troubleshooting

Preventive Maintenance





---

## Table of Contents

---

Model Nomenclature . . . . .	4
General Installation Information . . . . .	5
Vertical Dimensional Data . . . . .	6-7
Horizontal Dimensional Data . . . . .	8-9
Installing Horizontal Units . . . . .	10
Hanger Bracket Locations . . . . .	11
Duct System and Water Piping . . . . .	12
Condensate Drain . . . . .	12
Water Quality . . . . .	13
System Cleaning and Flushing . . . . .	14
Open Loop Ground Water Systems . . . . .	15
Hot Water Generator Connections . . . . .	16-17
Freeze Detection . . . . .	18
Electrical Connections . . . . .	18
Electrical Data . . . . .	19-21
Blower Performance Data . . . . .	21-27
Wiring Schematics . . . . .	28-34
Controls - Aurora Base Control . . . . .	36
Unit Startup . . . . .	40
Operating Limits and Operating Parameters . . . . .	41
Pressure Drop . . . . .	42
Reference Calculations and Legend . . . . .	43
Refrigerant Circuit Guidelines . . . . .	43
Compressor and Thermistor Resistance . . . . .	44
Heat of Extraction/Rejection Data . . . . .	45
Troubleshooting . . . . .	46
Startup/Troubleshooting Form . . . . .	46
Preventive Maintenance . . . . .	49
Replacement Procedures . . . . .	49
Revision Table . . . . .	50

# Model Nomenclature

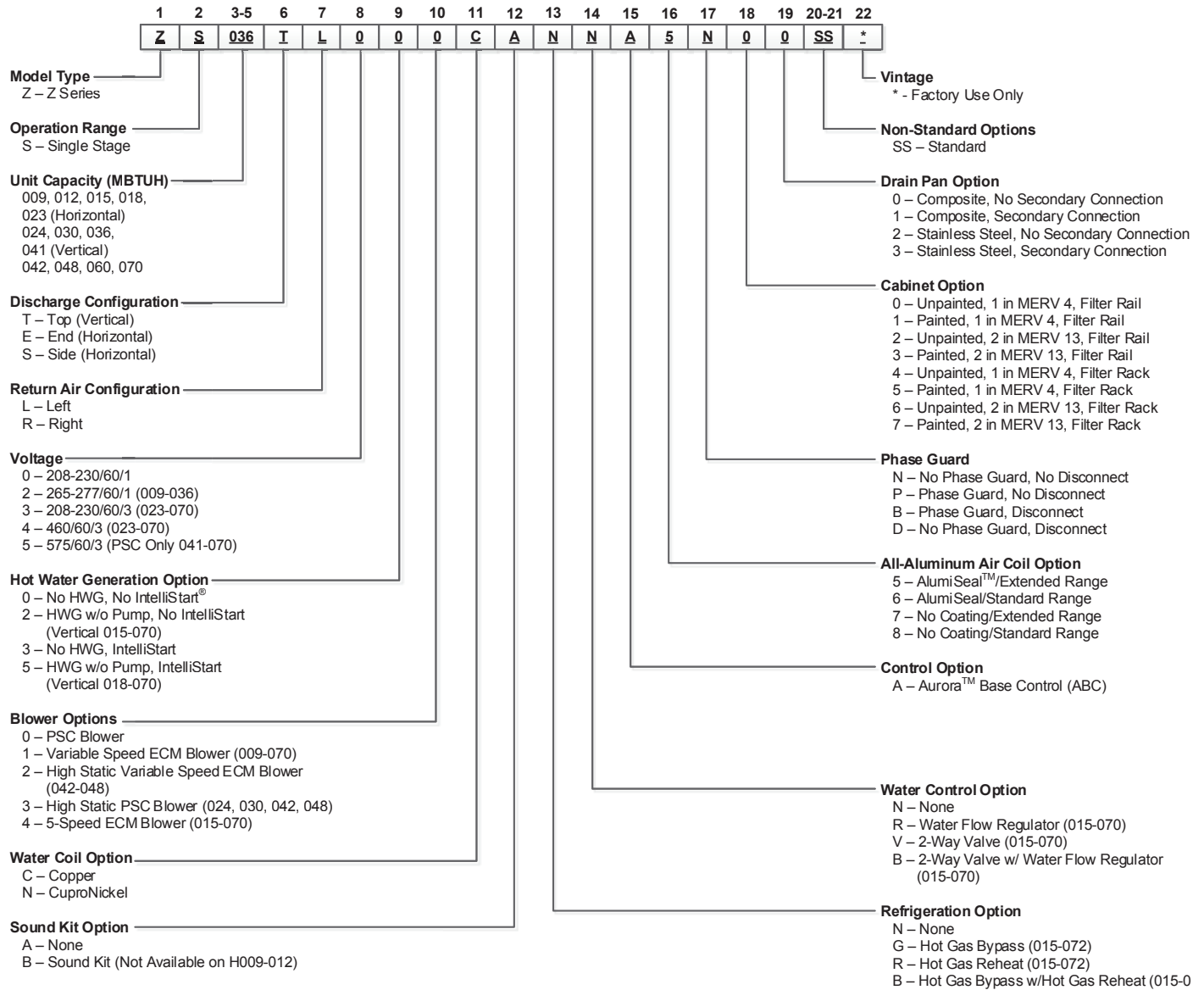

**Notes:**

- 1 - Phase Guard Only Available on 208-230/60/3 and 460/60/3
- 2 - IntelliStart is not available with Phase Guard

## General Installation Information

### Safety Considerations



**WARNING:** Before performing service or maintenance operations on a system, turn off main power switches to the indoor unit. If applicable, turn off the accessory heater power switch. Electrical shock could cause personal injury.

Installing and servicing heating and air conditioning equipment can be hazardous due to system pressure and electrical components. Only trained and qualified service personnel should install, repair or service heating and air conditioning equipment. Untrained personnel can perform the basic maintenance functions of cleaning coils and cleaning and replacing filters. All other operations should be performed by trained service personnel. When working on heating and air conditioning equipment, observe precautions in the literature, tags and labels attached to the unit and other safety precautions that may apply.

Follow all safety codes. Wear safety glasses and work gloves. Use a quenching cloth for brazing operations and have a fire extinguisher available.

### Moving and Storage

Move units in the normal "up" orientation. Horizontal units may be moved and stored per the information on the packaging. Do not stack more than three units in total height. Vertical units may be stored one upon another to a maximum height of two units. Do not attempt to move units while stacked. When the equipment is received, all items should be carefully checked against the bill of lading to be sure all crates and cartons have been received. Examine units for shipping damage, removing the units from the packaging if necessary. Units in question should also be internally inspected. If any damage is noted, the carrier should make the proper notation on the delivery receipt, acknowledging the damage.

### Unit Location

Locate the unit in an indoor area that allows for easy removal of the filter and access panels. Location should have enough space for service personnel to perform maintenance or repair. Provide sufficient room to make water, electrical and duct connection(s). If the unit is located in a confined space, such as a closet, provisions must be made for return air to freely enter the space by means of a louvered door, etc. Any access panel screws that would be difficult to remove after the unit is installed should be removed prior to setting the unit. On horizontal units, allow adequate room below the unit for a condensate drain trap and do not locate the unit above supply piping. **Care should be taken when units are located in unconditioned spaces to prevent damage from frozen water lines and excessive heat that could damage electrical components.**

### Installing Vertical Units

Prior to setting the unit in place, remove and discard the compressor hold down shipping bolt located at the front of the compressor mounting bracket.

Vertical units are available in left or right air return configurations. Top flow vertical units should be mounted level on a vibration absorbing pad slightly larger than the base to provide isolation between the unit and the floor. It is not necessary to anchor the unit to the floor (see figure below).

**Vertical Unit Mounting**

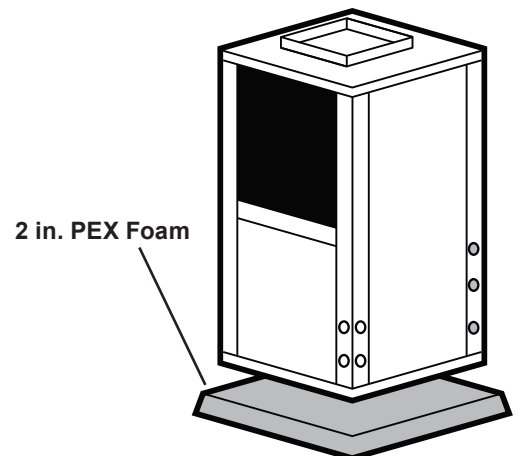

# Vertical Dimensional Data

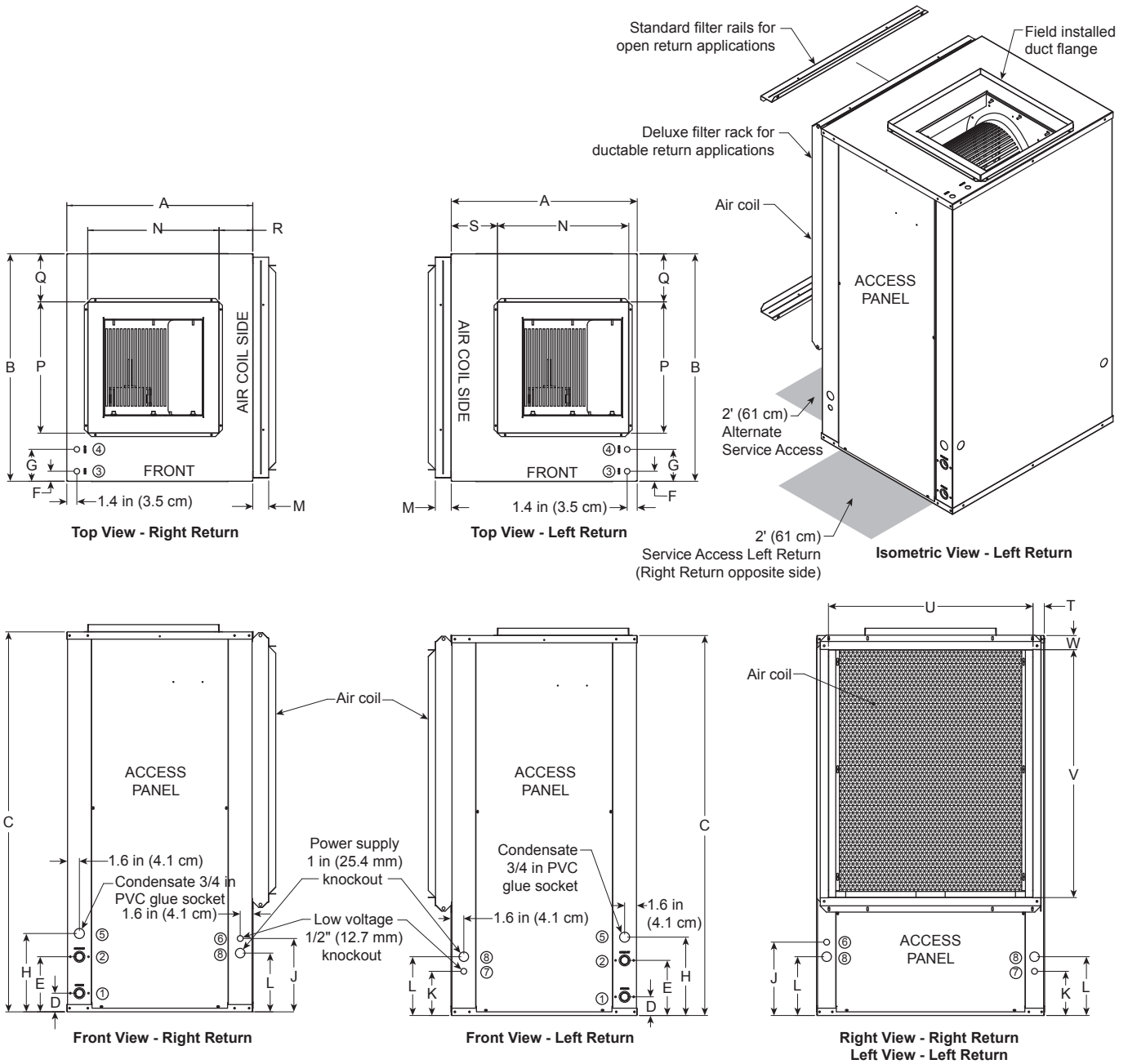

## Vertical Dimensional Data cont.

Vertical Models		Overall Cabinet			Water Connections							Electrical Knockouts		
		A	B	C	1	2	3	4	5	Loop	Knock-out	6	7	8
		Width	Depth	Height**	D	E	F	G	H			J	K	L
		In	Out	HWG In	HWG Out	Condensate	Water FPT	HWG Provisions	1/2 in. cond	1/2 in. cond	1 in. cond			
009-012	in.	22.5	22.2	23.7	2.6	5.6	N/A	N/A	8.8	1/2	N/A	7.4	3.4	5.4
	cm.	57.2	56.4	60.2	6.6	14.2	N/A	N/A	22.4	12.7 mm	N/A	18.8	8.6	13.7
015-018	in.	22.5	22.2	36.2	2.6	7.6	1.4	2.9	10.8	3/4	0.875	9.4	5.4	7.4
	cm.	57.2	56.4	91.9	6.6	19.3	3.6	7.4	27.4	19.1 mm	22.2 mm	23.9	13.7	18.8
024-030	in.	22.5	26.2	40.2	2.6	7.6	1.4	4.4	10.8	3/4	0.875	10.1	6.1	8.1
	cm.	57.2	66.5	102.1	6.6	19.3	3.6	11.2	27.4	19.1 mm	22.2 mm	25.7	15.5	20.6
036	in.	22.5	26.2	44.2	2.6	7.6	1.4	4.4	10.8	3/4	0.875	10.1	6.1	8.1
	cm.	57.2	66.5	112.3	6.6	19.3	3.6	11.2	27.4	19.1 mm	22.2 mm	25.7	15.5	20.6
041	in.	22.5	26.2	44.2	2.6	7.6	1.4	2.9	10.8	3/4	0.875	10.1	6.1	8.1
	cm.	57.2	66.5	112.3	6.6	19.3	3.6	7.4	27.4	19.1 mm	22.2 mm	25.7	15.5	20.6
042-048	in.	25.5	31.2	44.2	2.6	7.6	1.4	4.4	10.8	1	0.875	10.1	6.1	8.1
	cm.	64.8	79.2	112.3	6.6	19.3	3.6	11.2	27.4	25.4 mm	22.2 mm	25.7	15.5	20.6
060	in.	25.5	31.2	48.2	2.6	7.6	1.4	4.4	10.8	1	0.875	10.1	6.1	8.1
	cm.	64.8	79.2	122.4	6.6	19.3	3.6	11.2	27.4	25.4 mm	22.2 mm	25.7	15.5	20.6
070	in.	25.5	31.2	52.2	2.6	7.6	1.4	4.4	10.8	1	0.875	10.1	6.1	8.1
	cm.	64.8	79.2	132.6	6.6	19.3	3.6	11.2	27.4	25.4 mm	22.2 mm	25.7	15.5	20.6

Vertical Models		Discharge Connection duct flange installed (±0.10 in)						Return Connection* using deluxe filter rack (±0.10 in)			
		M	N	P	Q	R	S	T	U	V	W
		Filter Rack Width	Supply Width	Supply Depth					Return Depth	Return Height	
009-012	in.	2.2	10.0	10.0	6.1	9.4	9.4	2.1	18.1	10.0	1.9
	cm.	5.6	25.4	25.4	15.5	23.9	23.9	5.3	46.0	25.4	4.8
015-018	in.	2.2	14.0	14.0	4.1	4.3	7.7	2.1	18.1	20.0	1.9
	cm.	5.6	35.6	35.6	10.4	10.9	19.6	5.3	46.0	50.8	4.8
024-030	in.	2.2	14.0	14.0	6.1	4.5	7.7	2.1	22.1	22.1	1.9
	cm.	5.6	35.6	35.6	15.5	11.4	19.6	5.3	56.1	56.1	4.8
036	in.	2.2	14.0	14.0	6.1	4.5	7.7	2.1	22.1	26.1	1.9
	cm.	5.6	35.6	35.6	15.5	11.4	19.6	5.3	56.1	66.3	4.8
041	in.	2.2	18.0	18.0	4.1	3.9	3.9	2.1	22.1	26.1	1.9
	cm.	5.6	45.7	45.7	10.4	9.9	9.9	5.3	56.1	66.3	4.8
042-048	in.	2.2	18.0	18.0	6.6	4.6	6.3	1.6	28.1	26.0	2.0
	cm.	5.6	45.7	45.7	16.8	11.7	16.0	4.1	71.4	66.0	5.1
060	in.	2.2	18.0	18.0	6.6	4.6	6.3	1.6	28.1	30.0	2.0
	cm.	5.6	45.7	45.7	16.8	11.7	16.0	4.1	71.4	76.2	5.1
070	in.	2.2	18.0	18.0	6.6	4.6	6.3	1.6	28.1	34.0	2.0
	cm.	5.6	45.7	45.7	16.8	11.7	16.0	4.1	71.4	86.4	5.1

Condensate is 3/4 in. PVC female glue socket and is switchable from side to front.

\*Dimensions for return connections are for the deluxe filter rack that is suitable for ducted return applications and extends 3.25 in. [8.26 cm] from the unit. The open filter rack, used in non-ducted returns, extends 2.2 in. [5.59 cm] from the unit.

\*\*Discharge flange is field installed and extends 1 in. (25.4 mm) from top of cabinet.

11/10/09

## Vertical Disconnect

When using disconnect, do not use dimension L from the standard vertical dimensional data. Use dimension LL from the vertical disconnect dimensional data.

Vertical Models	LL
009-012	Externally Mounted
015-018	18.8 [47.8]
024-030	14.3 [36.3]
036	15.3 [38.9]
042-048	14.3 [36.3]
060	14.3 [36.3]
070	14.3 [36.3]

Dimensions in inches [cm]

02/06/13

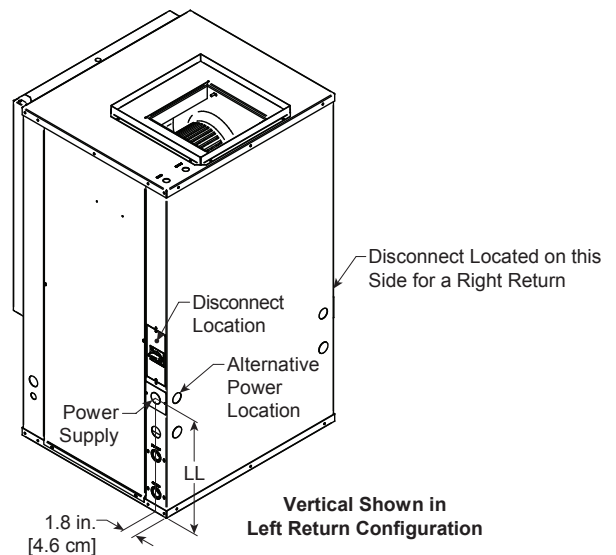

# Horizontal Dimensional Data

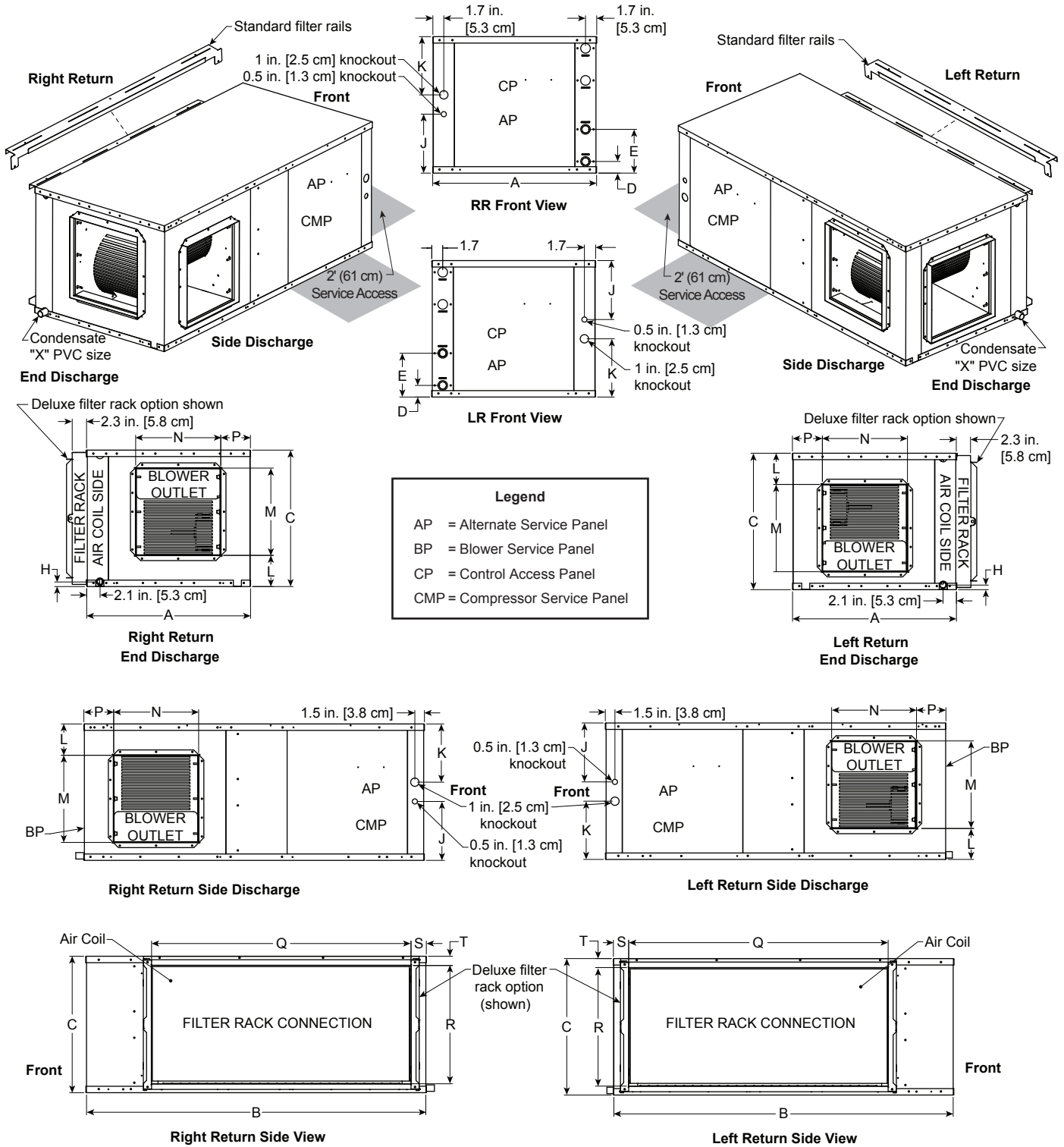



## Horizontal Dimensional Data cont.

Horizontal Models		Overall Cabinet			Water Connections				Electrical Knockouts	
		A	B	C	1	2	3	Loop	J	K
		Width	Depth	Height*	D	E	H		1/2 in. cond	1 in. cond
009-012	in.	19.2	30.9	11.9	1.8	4.8	0.8	1/2	4.5	4.5
	cm.	48.8	78.5	30.2	4.6	12.2	2.0	12.7 mm	11.4	11.4
015-023	in.	22.5	42.0	17.2	1.8	6.8	0.8	3/4	7.1	7.1
	cm.	57.2	106.7	43.7	4.6	17.3	2.0	19.05 mm	18.0	18.0
024-030	in.	22.5	42.0	19.2	1.8	6.8	0.8	3/4	9.2	7.1
	cm.	57.2	106.7	48.8	4.6	17.3	2.0	19.05 mm	23.4	18.0
036	in.	22.5	45.0	19.2	1.8	6.8	0.8	3/4	9.2	7.1
	cm.	57.2	114.3	48.8	4.6	17.3	2.0	19.05 mm	23.4	18.0
042-048	in.	25.5	48.0	21.2	1.8	6.8	0.8	1	9.2	9.1
	cm.	64.8	121.9	53.8	4.6	17.3	2.0	25.4 mm	23.4	23.1
060	in.	25.5	53.0	21.2	1.8	6.8	0.8	1	9.2	9.1
	cm.	64.8	134.6	53.8	4.6	17.3	2.0	25.4 mm	23.4	23.1
070	in.	25.5	61.0	21.2	1.8	6.8	0.8	1	9.2	9.1
	cm.	64.8	154.9	53.8	4.6	17.3	2.0	25.4 mm	23.4	23.1

Horizontal Models		Discharge Connection duct flange installed (±0.10 in)				Return Connection* using deluxe filter rack option (±0.10 in)				PVC Size
		L	M	N	P	Q	R	S	T	X
			Supply Width	Supply Depth		Return Depth	Return Height			
009-012	in.	2.3	8.0	10.0	2.3	15.4	9.4	3.0	1.4	1/2
	cm.	5.8	20.3	25.4	5.8	39.1	23.9	7.6	3.6	1.3
015-023	in.	5.7	10.5	9.4	4.9	23.4	14.5	2.0	1.4	3/4
	cm.	14.5	26.7	23.9	12.4	59.4	36.8	5.1	3.6	1.9
024-030	in.	6.7	10.5	9.4	4.9	27.4	16.4	2.0	1.5	3/4
	cm.	17.0	26.7	23.9	12.4	69.6	41.7	5.1	3.8	1.9
036	in.	6.7	10.5	9.4	4.9	30.4	16.4	2.1	1.5	3/4
	cm.	17.0	26.7	23.9	12.4	77.2	41.7	5.3	3.8	1.9
042-048	in.	4.9	13.6	13.2	4.6	35.4	18.6	2.4	1.5	3/4
	cm.	12.4	34.5	33.5	11.7	89.9	47.2	6.1	3.8	1.9
060	in.	4.9	13.6	13.2	4.6	40.4	18.4	2.4	1.5	3/4
	cm.	12.4	34.5	33.5	11.7	102.6	46.7	6.1	3.8	1.9
070	in.	4.9	13.6	13.2	4.6	45.6	18.6	2.3	1.5	3/4
	cm.	12.4	34.5	33.5	11.7	115.8	47.2	5.8	3.8	1.9

\*Dimensions for return connections are for the deluxe filter rack that is suitable for ducted return applications and extends 3.25 in. [8.26 cm] from the unit. The open filter rack, used in non-ducted returns, extends 2.2 in. [5.59 cm] from the unit. Condensate 3/4 in. PVC stub extends from cabinet approximately 1-1/2 in. [38.1 mm]

10/29/13

## Horizontal Disconnect

When using disconnect, do not use dimension K from the standard horizontal dimensional data. Use dimension KK from the horizontal disconnect dimensional data.

Horizontal Models	KK
009-012	Externally Mounted
015-018	8.2 [20.8 ]
024-030	9.2 [23.4]
036	9.2 [23.4]
042-048	11.2 [28.4]
060	10.2 [25.9]
070	11.2 [28.4]

Dimensions in inches [cm]

02/06/13

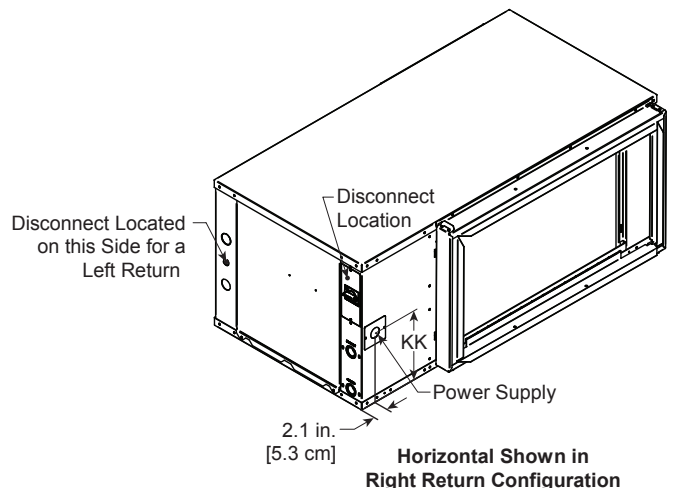

## Installing Horizontal Units

### Installing Horizontal Units

Remove and discard the compressor hold down shipping bolt located at the front of the compressor mounting bracket prior to setting the unit in place. Horizontal units are available with side or end discharge.

**NOTE:** Left (Right) Return Side Discharge cannot be converted to Left (Right) Return End Discharge or vice versa, without additional custom sheet metal parts. Horizontal units are normally suspended from a ceiling by four (009-060 models) or five (070-072 models) 3/8 in. diameter threaded rods. The rods are usually attached to the unit by hanger bracket kits furnished with each unit.

Lay out the threaded rods per the Hanger Bracket Dimensions table. Assemble the hangers to the unit as shown. Securely tighten the brackets to the unit using the weld nuts located on the underside of the bottom panel. When attaching the hanger rods to the bracket, a double nut is required since vibration could loosen a single nut. To allow filter access, install hanger brackets as illustrated in the Hanger Bracket Locations section. The unit

should be pitched approximately 1/4 in. towards the drain in both directions to facilitate the removal of condensate. Use only the bolts provided in the kit to attach hanger brackets. The use of longer bolts could damage internal parts.

Some applications require the installation of horizontal units on an attic floor. In this case, the unit should be set in a full size secondary drain pan on top of a vibration absorbing pad. The secondary drain pan prevents possible condensate overflow or water leakage damage to the ceiling. The secondary drain pan is usually placed on a plywood base isolated from the ceiling joists by additional layers of vibration absorbing material.



**CAUTION:** Do not use rods smaller than 3/8 in. diameter since they may not be strong enough to support the unit. The rods must be securely anchored to the ceiling.

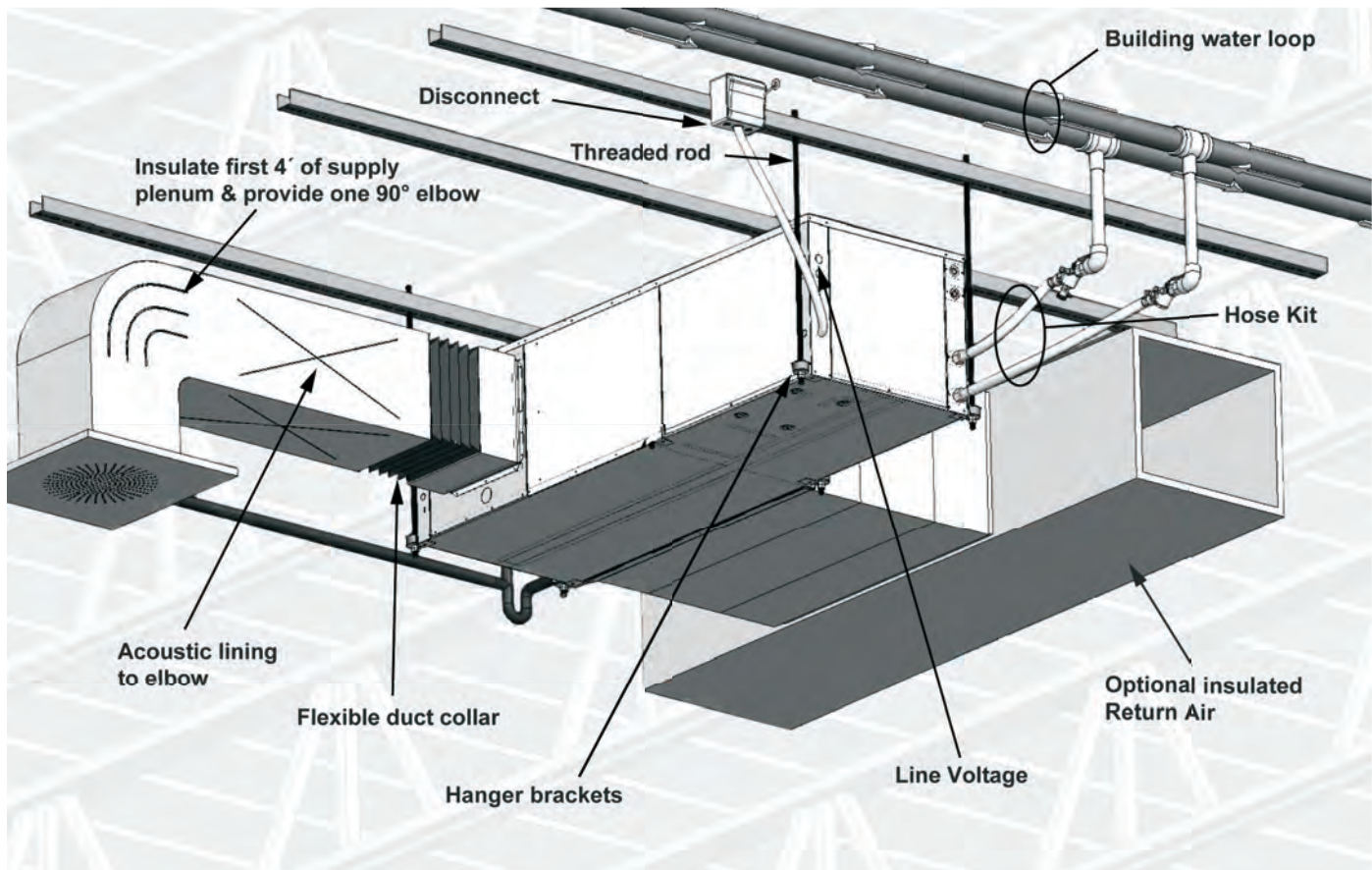

# Hanger Bracket Locations

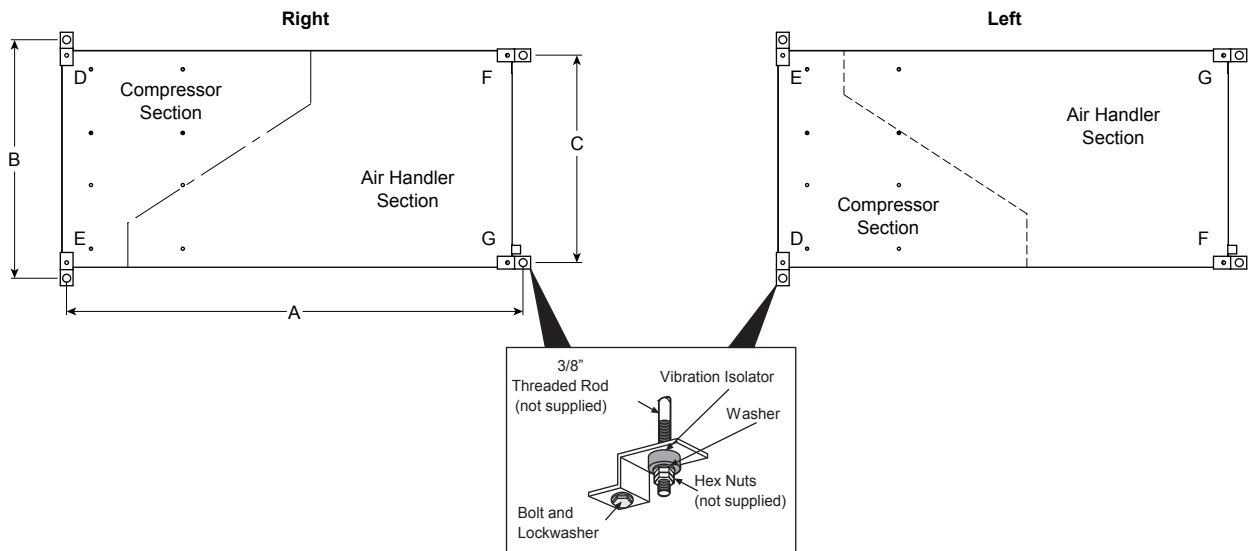

## Hanger Dimensions

Model	Hanger Kit Part Number	Unit Hanger Dimensions		
		A	B	C
009-012	in.	31.7	21.8	18.1
	cm	[80.5]	[55.4]	[46.0]
015-023	in.	42.8	25.1	21.4
	cm	[108.6]	[63.8]	[54.4]
024-030	in.	42.8	25.1	21.4
	cm	[108.7]	[63.8]	[54.4]
036	in.	45.8	25.1	21.4
	cm	[116.3]	[63.8]	[54.4]
042-048	in.	48.8	28.1	24.4
	cm	[124.0]	[71.4]	[62.0]
060	in.	53.8	28.1	24.4
	cm	[136.7]	[71.4]	[62.0]
070	in.	61.8	28.1	24.4
	cm	[157.0]	[71.4]	[62.0]

10/29/13

## Weight Distribution

Model		Vertical Shipping Weight	Horizontal Shipping Weight	Horizontal Weight Distribution			
				Front		Back	
				D	E	F	G
009	lb.	110	120	46	23	26	25
	kg	[50]	[54]	[21]	[11]	[12]	[11]
012	lb.	115	125	48	24	27	26
	kg	[52]	[57]	[22]	[11]	[12]	[12]
015	lb.	165	175	67	34	37	36
	kg	[75]	[79]	[31]	[15]	[17]	[17]
018	lb.	170	180	69	35	38	38
	kg	[77]	[82]	[31]	[16]	[17]	[17]
023	lb.	na	185	71	36	39	39
	kg	na	[84]	[32]	[16]	[18]	[17]
024	lb.	230	245	94	47	52	51
	kg	[104]	[111]	[43]	[22]	[24]	[23]
030	lb.	240	255	98	49	54	53
	kg	[109]	[116]	[44]	[22]	[25]	[24]
036	lb.	265	285	110	55	61	59
	kg	[120]	[129]	[50]	[25]	[28]	[27]
041	lb.	275	na	na	na	na	na
	kg	[125]	na	na	na	na	na
042	lb.	285	300	115	58	64	63
	kg	[129]	[136]	[52]	[26]	[29]	[28]
048	lb.	290	310	119	60	66	65
	kg	[132]	[141]	[54]	[27]	[30]	[29]
060	lb.	335	360	138	70	77	75
	kg	[152]	[163]	[63]	[32]	[35]	[34]
070	lb.	380	405	156	78	86	84
	kg	[172]	[184]	[71]	[36]	[39]	[38]

11/10/09

## Duct System

An air outlet collar is provided on vertical top flow units and all horizontal units to facilitate a duct connection. A flexible connector is recommended for discharge and return air duct connections on metal duct systems. Uninsulated duct should be insulated with a minimum of 1-inch duct insulation. Application of the unit to uninsulated ductwork in an unconditioned space is not recommended as the unit's performance will be adversely affected.

If the unit is connected to existing ductwork, check the duct system to ensure that it has the capacity to accommodate the air required for the unit application. If the duct is too small, as in the replacement of heating only systems, larger ductwork should be installed. All existing ductwork should be checked for leaks and repaired if necessary.

The duct system should be sized to handle the design airflow quietly and efficiently. To maximize sound attenuation of the unit blower, the supply and return plenums should include an internal duct liner of fiberglass or constructed of ductboard for the first few feet. On systems employing a sheet metal duct system, canvas connectors should be used between the unit and the ductwork. If air noise or excessive airflow is a problem, the blower speed can be changed.



**CAUTION: Be sure to remove the shipping material from the blower discharge before connecting ductwork.**

## Water Piping

The proper water flow must be provided to each unit whenever the unit operates. To assure proper flow, use pressure/temperature ports to determine the flow rate. These ports should be located at the supply and return water connections on the unit. The proper flow rate cannot be accurately set without measuring the water pressure drop through the refrigerant-to-water heat exchanger.

All source water connections on commercial units are fittings that accept a male pipe thread (MPT). Insert the connectors by hand, then tighten the fitting with a wrench to provide a leakproof joint. When connecting to an open loop (groundwater) system, thread any copper MPT fitting into the connector and tighten in the same manner as described above.

## Condensate Drain

On vertical units, the internal condensate drain assembly consists of a drain tube which is connected to the drain pan, a 3/4 in. PVC female adapter and a flexible connecting hose. The female adapter may exit either the front or the side of the cabinet. The adapter should be glued to the field-installed PVC condensate piping. On vertical units, a condensate hose is inside all cabinets as a trapping loop; therefore, an external trap is not necessary.

On horizontal units, a PVC stub or stainless steel tube is provided for condensate drain piping connection. An external trap is required (see below). If a vent is necessary, an open stand pipe may be applied to a tee in the field-installed condensate piping.

### Horizontal Drain Connection (Composite Drain Pan)

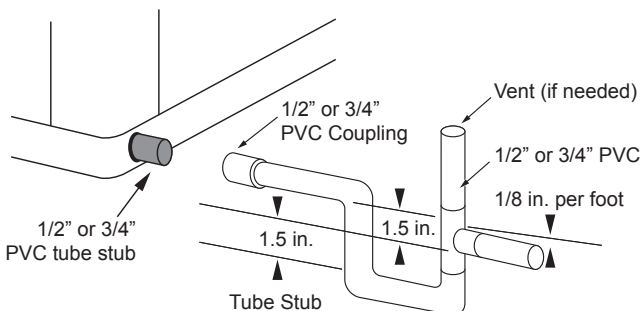

### Unit Pitch for Drain

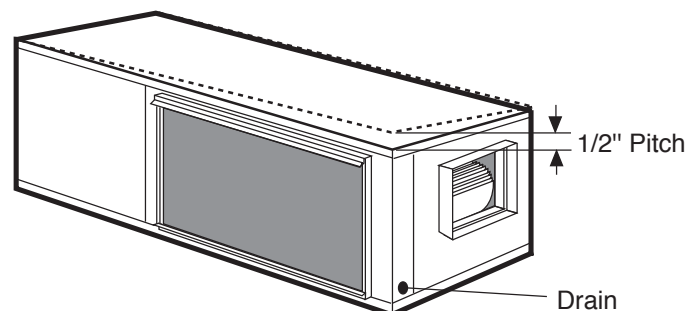

## Water Quality

In ground water situations where scaling could be heavy or where biological growth such as iron bacteria will be present, a closed loop system is recommended. The heat exchanger coils in ground water systems may, over a period of time, lose heat exchange capabilities due to a buildup of mineral deposits inside. These can be cleaned, but only by a qualified service mechanic, as special solutions and pumping equipment are required. Hot water generator coils can likewise become scaled and possibly plugged.

In areas with extremely hard water, the owner should be informed that the heat exchanger may require occasional flushing. Failure to adhere to the guidelines in the water quality table could result in loss of warranty.

Units with cupronickel heat exchangers are recommended for open loop applications due to the increased resistance to build-up and corrosion, along with reduced wear caused by acid cleaning.

Material		Copper	90/10 Cupronickel	316 Stainless Steel
pH	Acidity/Alkalinity	7 - 9	7 - 9	7 - 9
Scaling	Calcium and Magnesium Carbonate	(Total Hardness) less than 350 ppm	(Total Hardness) less than 350 ppm	(Total Hardness) less than 350 ppm
Corrosion	Hydrogen Sulfide	Less than 0.5 ppm (rotten egg smell appears at 0.5 ppm)	10 - 50 ppm	Less than 1 ppm
	Sulfates	Less than 125 ppm	Less than 125 ppm	Less than 200 ppm
	Chlorine	Less than 0.5 ppm	Less than 0.5 ppm	Less than 0.5 ppm
	Chlorides	Less than 20 ppm	Less than 125 ppm	Less than 300 ppm
	Carbon Dioxide	Less than 50 ppm	10 - 50 ppm	10 - 50 ppm
	Ammonia	Less than 2 ppm	Less than 2 ppm	Less than 20 ppm
	Ammonia Chloride	Less than 0.5 ppm	Less than 0.5 ppm	Less than 0.5 ppm
	Ammonia Nitrate	Less than 0.5 ppm	Less than 0.5 ppm	Less than 0.5 ppm
	Ammonia Hydroxide	Less than 0.5 ppm	Less than 0.5 ppm	Less than 0.5 ppm
	Ammonia Sulfate	Less than 0.5 ppm	Less than 0.5 ppm	Less than 0.5 ppm
	Total Dissolved Solids (TDS)	Less than 1000 ppm	1000 - 1500 ppm	1000 - 1500 ppm
	LSI Index	+0.5 to -0.5	+0.5 to -0.5	+0.5 to -0.5
Iron Fouling (Biological Growth)	Iron, FE <sup>2+</sup> (Ferrous) Bacterial Iron Potential	< 0.2 ppm	< 0.2 ppm	< 0.2 ppm
	Iron Oxide	Less than 1 ppm, above this level deposition will occur	Less than 1 ppm, above this level deposition will occur	Less than 1 ppm, above this level deposition will occur
Erosion	Suspended Solids	Less than 10 ppm and filtered for max. of 600 micron size	Less than 10 ppm and filtered for max. of 600 micron size	Less than 10 ppm and filtered for max. of 600 micron size
	Threshold Velocity (Fresh Water)	< 6 ft/sec	< 6 ft/sec	< 6 ft/sec

NOTES: Grains = ppm divided by 17  
mg/L is equivalent to ppm

2/22/12



## System Cleaning and Flushing

### Cleaning and Flushing

Prior to start up of any heat pump, the water circulating system must be cleaned and flushed of all dirt and debris.

If the system is equipped with water shutoff valves, the supply and return runouts must be connected together at each unit location (This will prevent the introduction of dirt into the unit, see Flushing with Water Shutoff Valve Equipped Systems illustration). The system should be filled at the water make-up connection with all air vents open. After filling, vents should be closed.

#### Flushing with Water Shutoff Valve Equipped Systems

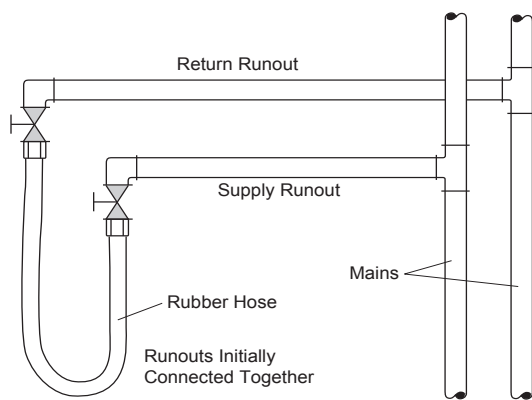

The contractor should start the main circulator with the pressure reducing valve makeup open. Vents should be checked in sequence to bleed off any trapped air and to verify circulation through all components of the system.

As water circulates through the system, the contractor should check and repair any leaks found in the piping system. Drain(s) at the lowest point(s) in the system should be opened for initial flush and blowdown, making sure water fill valves are set at the same rate. Check the pressure gauge at the pump suction and manually adjust the make-up water valve to hold the same positive pressure both before and after opening the drain valves. Flushing should continue for at least two hours, or longer if required, until drain water is clean and clear.

The supplemental heater and/or circulator pump, if used, should be shut off. All drains and vents should be opened to completely drain the system. Short-circuited supply and return runouts should now be connected to the unit supply and return connections.

Refill the system with clean water. Test the system water for acidity and treat as required to leave the water slightly alkaline (pH 7.5 to 8.5). The specified percentage of antifreeze may also be added at this time. Use commercial grade antifreeze designed for HVAC systems only. Environol™ brand antifreeze is recommended.

Once the system has been filled with clean water and antifreeze (if used), precautions should be taken to protect the system from dirty water conditions. Dirty water will result in system-wide degradation of performance, and solids may clog valves, strainers, flow regulators, etc. Additionally, the heat exchanger may become clogged which reduces compressor service life and can cause premature unit failure.

In boiler/tower application, set the loop control panel set points to desired temperatures. Supply power to all motors and start the circulating pumps. After full flow has been established through all components including the heat rejector (regardless of season), air vented and loop temperatures stabilized, each of the units will be ready for check, test and start up and for air and water balancing.

### Ground Source Loop System Checkout

Once piping is completed between the unit pumping system and ground loop, final purging and charging of the loop is needed. A high pressure pump is needed to achieve adequate flow velocity in the loop to purge air and dirt particles from the loop itself. Antifreeze solution is used in most areas to prevent freezing. Flush the system adequately to remove as much air as possible; then pressurize the loop to a static pressure of 40-50 PSI (summer) or 50-75 PSI (winter). This is normally adequate for good system operation. Loop static pressure may decrease soon after initial installation, due to pipe expansion and loop temperature change. Running the unit for at least 30 minutes after the system has been completely purged of air will allow for the "break-in" period. It may be necessary to adjust static loop pressure (by adding water) after the unit has run for the first time. Loop static pressure will also fluctuate with the seasons. Pressures will be higher in the winter months than during the cooling season. This fluctuation is normal and should be considered when charging the system initially.

Ensure the pump provides adequate flow through the unit by checking pressure drop across the heat exchanger. Usually 2.25-3.0 GPM of flow per ton of cooling capacity is recommended in earth loop applications.

## Open Loop Ground Water Systems

Typical open loop piping is shown below. Always maintain water pressure in the heat exchanger by placing water control valves at the outlet of the unit to prevent mineral precipitation. Use a closed, bladder-type expansion tank to minimize mineral formation due to air exposure. Insure proper water flow through the unit by checking pressure drop across the heat exchanger and comparing it to the figures in unit capacity data tables in the specification catalog.

1.5-2 GPM of flow per ton of cooling capacity is recommended in open loop applications. Due to only minor differences in flow rate from low to high, only one solenoid valve should be used. The valve should be sized for full flow.

Discharge water from the unit is not contaminated in any manner and can be disposed of in various ways, depending on local codes, i.e. recharge well, storm sewer, drain field, adjacent stream or pond, etc. Most local codes forbid the use of sanitary sewer for disposal. Consult your local building and zoning departments to assure compliance in your area.

### Open System - Groundwater Application

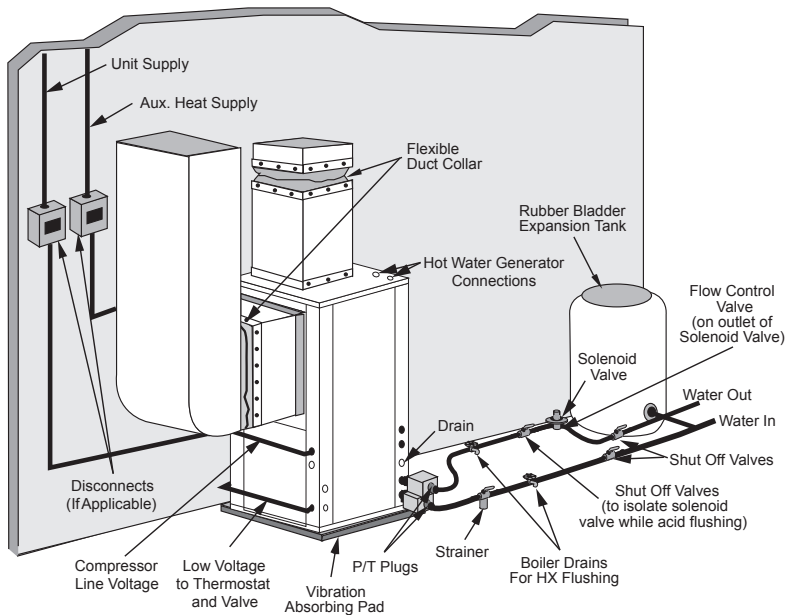

## Hot Water Generator Connections

The heat reclaiming hot water generator coil is of vented double-wall copper construction and is suitable for potable water.

To maximize the benefits of the hot water generator a minimum 50-gallon water heater is recommended. For higher demand applications, use an 80-gallon water heater or two 50-gallon water heaters connected in a series as shown below. Electric water heaters are recommended. Make sure all local electrical and plumbing codes are met for installing a hot water generator. A water softener is recommended with hard water (greater than 10 grains or 170 total hardness).

### Water Tank Preparation

To install a unit with a hot water generator, follow these installation guidelines.

1. Turn off the power to the water heater.
2. Attach a water hose to the water tank drain connection and run the other end of the hose to an open drain or outdoors.
3. Close the cold water inlet valve to the water heater tank.
4. Drain the tank by opening the valve on the bottom of the tank, then open the pressure relief valve or hot water faucet.
5. Flush the tank by opening the cold water inlet valve to the water heater to free the tank of sediments. Close when draining water is clear.
6. Disconnect the garden hose and remove the drain valve from the water heater.
7. Refer to Plumbing Installation and Hot Water Generator Startup.

### Plumbing Installation

1. Inspect the dip tube in the water heater cold inlet for a check valve. If a check valve is present it must be removed or damage to the hot water generator circulator will occur.
2. Remove drain valve and fitting.
3. Thread the 3/4-inch NPT x 3-1/2-inch brass nipple into the water heater drain port.
4. Attach the center port of the 3/4-inch FPT tee to the opposite end of the brass nipple.
5. Attach the 1/2-inch copper to 3/4-inch NPT adaptor to the side of the tee closest to the unit.
6. Install the drain valve on the tee opposite the adaptor.
7. Run interconnecting tubing from the tee to HWG water out.
8. Cut the cold water "IN" line going to the water heater.

### Typical Hot Water Generator Installation

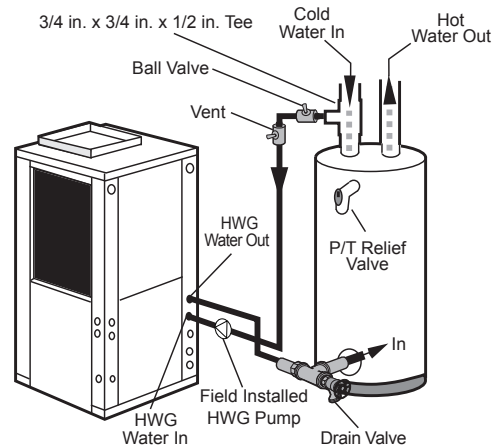

### Hot Water Generator Installation In Preheat Tank

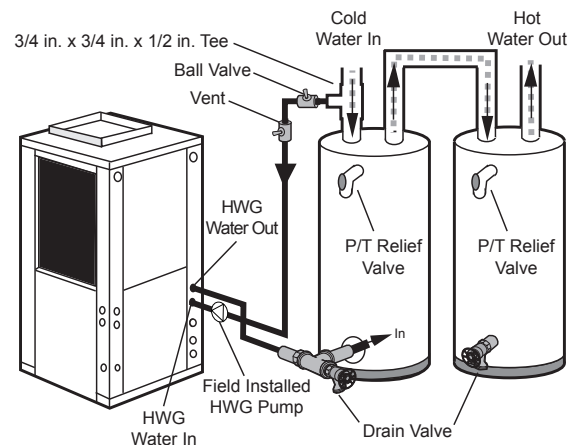

**NOTE:** This configuration maximizes hot water generator capability.



**CAUTION:** Elements will burn out if energized dry.

9. Insert the reducing solder tee in line with cold water "IN" line as shown.
10. Run interconnecting copper tubing between the unit DHW water "IN" and the tee (1/2-inch nominal). The recommended maximum distance is 50 feet.
11. To prevent air entrapment in the system, install a vent coupling at the highest point of the interconnecting lines.
12. Insulate all exposed surfaces of both connecting water lines with 3/8-inch wall closed cell insulation.

**NOTE:** All plumbing and piping connections must comply with local plumbing codes.



## Hot Water Generator Connections cont.

### Hot Water Generator Startup

1. Make sure the power is off to the heat pump. Connect the wire from the hot water generator pump to T1 on the contactor.
2. Close the drain valve to the water heater.
3. Open the cold water supply to the tank.
4. Open a hot water faucet in the building to bleed air from the system. Close when full.
5. Open the pressure relief valve to bleed any remaining air from the tank, then close.
6. If so equipped, turn the venting (burping) screw in the center of the pump two (2) turns open (water will drip out), wait until all air is purged from the pump, then tighten the plug. Use vent couplings to bleed air from the lines.
7. Carefully inspect all plumbing for water leaks and correct as required.
8. Before restoring electrical supply to the water heater, adjust the temperature setting on the tank.
  - On tanks with both upper and lower elements, the lower element should be turned down to the lowest setting, approximately 100°F. The upper element should be adjusted to 120°F to 130°F. Depending upon the specific needs of the customer, you may want to adjust the upper element differently.
  - On tanks with a single element, lower the thermostat setting to 120°F.
9. After the thermostat(s) is adjusted, replace the access cover and restore electrical supply to the water heater.
10. Make sure that any valves in the hot water generator circuit are open.
11. Turn on the unit to heating.
12. The HWG pump should be running. When the pump is first started, turn the venting (burping) screw (if equipped) in the center of the pump two (2) turns open until water dribbles out, then replace. Allow the pump to run for at least five minutes to ensure that water has filled the circulator properly.
13. The temperature difference between the water entering and leaving the hot water generator should be 5°F to 15°F. The water flow should be approximately 0.4 gpm per ton of nominal cooling.
14. Allow the unit to heat water for 15 to 20 minutes to be sure operation is normal.



**CAUTION: Never operate the HWG circulating pump while dry. If the unit is placed in operation before the hot water generator piping is connected, be sure that the pump wires are disconnected from the contactor.**

## Freeze Detection

For Versatec board, set SW1-2 on the printed circuit board for applications using a closed loop antifreeze solution to "LOOP" (15°F) [-9.4°C]. On applications using an open loop/ground water system (or closed loop no antifreeze), set this dip switch to "WELL" (30°F) [-1.1°C], the factory default setting. (Refer to the Dip Switch Field Selection table).

## Electrical Connections

### General

Be sure the available power is the same voltage and phase as that shown on the unit serial plate. Line and low voltage wiring must be done in accordance with local codes or the National Electric Code, whichever is applicable.

### Unit Power Connection

Connect the incoming line voltage wires to L1 and L2 of the contactor for single-phase unit. Consult the Unit Electrical Data for correct fuse sizes.

### 208 Volt Operation

All Z Series 208/230 units are factory wired for 230 volt operation. For 208 volt operation, the red and blue transformer wires must be switched on terminal strip PS.



**CAUTION:** When installing a unit with an ECM blower motor in 460/60/3 voltage, a neutral wire is required to allow proper unit operation.

### Aurora Base Control Box

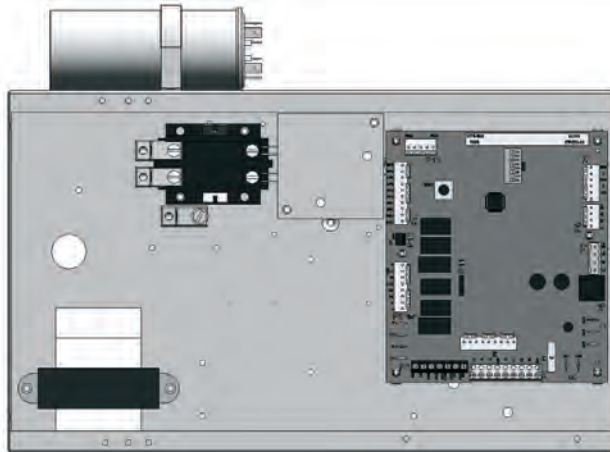

# Electrical Data

## PSC Motor

Model	Rated Voltage	Voltage Min/Max	Compressor				Blower Motor FLA	Total Unit FLA	Min Circ Amp	Max Fuse/HACR
			MCC	RLA	LRA	LRA**				
009	208-230/60/1	187/253	6.4	4.1	21.0	n/a	0.6	4.7	5.7	10/15
	265/60/1	238/292	6.7	4.3	22.0	n/a	0.6	4.9	6.0	10/15
012	208-230/60/1	187/253	7.7	4.9	25.0	n/a	0.6	5.5	6.7	10/15
	265/60/1	238/292	7.0	4.5	22.0	n/a	0.6	5.1	6.2	10/15
015	208-230/60/1	187/253	9.2	5.9	29.0	n/a	1.1	7.0	8.5	10/15
	265/60/1	238/292	7.8	5.0	28.0	n/a	1.0	6.0	7.2	10/15
018	208-230/60/1	187/253	10.4	6.7	33.5	13.4	1.1	7.8	9.5	15
	265/60/1	238/292	8.7	5.6	28.0	n/a	1.0	6.6	8.0	10/15
023	208-230/60/1	187/253	21.0	13.5	58.3	23.3	1.2	14.7	18.1	30
	265/60/1	238/292	14.0	9.0	54.0	n/a	1.1	10.1	12.4	20
	208-230/60/3	187/253	11.0	7.1	55.0	33.0	1.2	8.3	10.1	15
	460/60/3	414/506	5.5	3.5	28.0	16.8	0.6	4.1	5.0	10/15
024	208-230/60/1	187/253	21.0	13.5	58.3	23.3	1.2	14.7	18.1	30
	265/60/1	238/292	14.0	9.0	54.0	n/a	1.1	10.1	12.4	20
	208-230/60/3	187/253	11.0	7.1	55.0	33.0	1.2	8.3	10.1	15
	460/60/3	414/506	5.5	3.5	28.0	16.8	0.6	4.1	5.0	10/15
024*	208-230/60/1	187/253	21.0	13.5	58.3	23.3	1.5	15.0	18.4	30
	265/60/1	238/292	14.0	9.0	54.0	n/a	1.5	10.5	12.8	20
	208-230/60/3	187/253	11.0	7.1	55.0	33.0	1.5	8.6	10.4	15
	460/60/3	414/506	5.5	3.5	28.0	16.8	1.0	4.5	5.4	10/15
030	208-230/60/1	187/253	22.0	14.1	73.0	29.2	1.5	15.6	19.1	30
	265/60/1	238/292	17.5	11.2	60.0	n/a	1.5	12.7	15.5	25
	208-230/60/3	187/253	13.9	8.9	58.0	34.8	1.5	10.4	12.6	20
	460/60/3	414/506	6.5	4.2	28.0	16.8	1.0	5.2	6.3	10/15
030*	208-230/60/1	187/253	22.0	14.1	73.0	29.2	2.2	16.3	19.8	30
	265/60/1	238/292	17.5	11.2	60.0	n/a	2.0	13.2	16.0	25
	208-230/60/3	187/253	13.9	8.9	58.0	34.8	2.2	11.1	13.3	20
	460/60/3	414/506	6.5	4.2	28.0	16.8	1.1	5.3	6.4	10/15
036	208-230/60/1	187/253	27.0	17.3	96.7	38.7	2.2	19.5	23.8	40
	265/60/1	238/292	19.0	12.2	72.0	n/a	1.1	13.3	16.3	20
	208-230/60/3	187/253	20.0	12.8	95.0	57.0	2.2	15.0	18.2	30
	460/60/3	414/506	10.0	6.4	45.0	27.0	1.1	7.5	9.1	15
041	208-230/60/1	187/253	31.0	20.0	115.0	46.0	3.5	23.5	28.5	45
	208-230/60/3	187/253	20.0	12.8	95.0	57.0	3.5	16.3	19.5	30
	460/60/3	414/506	10.0	6.4	45.0	27.0	1.8	8.2	9.8	15
	575/60/3	517/633	8.5	5.4	38.0	n/a	1.4	6.8	8.2	10/15
042	208-230/60/1	187/253	31.0	20.0	115.0	46.0	3.5	23.5	28.5	45
	208-230/60/3	187/253	20.0	12.8	95.0	57.0	3.5	16.3	19.5	30
	460/60/3	414/506	10.0	6.4	45.0	27.0	1.8	8.2	9.8	15
	575/60/3	517/633	8.5	5.4	38.0	n/a	1.4	6.8	8.2	10/15
042*	208-230/60/1	187/253	31.0	20.0	115.0	46.0	4.6	24.6	29.6	45
	208-230/60/3	187/253	20.0	12.8	95.0	57.0	4.6	17.4	20.6	30
	460/60/3	414/506	10.0	6.4	45.0	27.0	2.3	8.7	10.3	15
	575/60/3	517/633	8.5	5.4	38.0	n/a	1.9	7.3	8.7	10/15
048	208-230/60/1	187/253	32.0	21.0	115.0	46.0	3.5	24.5	29.8	50
	208-230/60/3	187/253	25.0	16.0	115.0	69.0	3.5	19.5	23.5	35
	460/60/3	414/506	12.0	7.7	50.0	30.0	1.8	9.5	11.4	15
048*	208-230/60/1	187/253	32.0	21.0	115.0	46.0	4.6	25.6	30.9	50
	208-230/60/3	187/253	25.0	16.0	115.0	69.0	4.6	20.6	24.6	40
	460/60/3	414/506	12.0	7.7	50.0	30.0	2.3	10.0	11.9	15
	575/60/3	517/633	10.0	6.4	40.0	n/a	1.9	8.3	9.9	15
060	208-230/60/1	187/253	41.0	26.3	150.0	60.0	5.9	32.3	38.8	60
	208-230/60/3	187/253	27.5	17.6	120.0	72.0	5.9	23.5	27.9	45
	460/60/3	414/506	13.0	8.3	70.0	42.0	3.0	11.3	13.4	20
	575/60/3	517/633	11.5	7.4	53.0	n/a	1.9	9.3	11.2	15
070	208-230/60/1	187/253	47.0	30.1	145.0	58.0	5.9	36.0	43.5	70
	208-230/60/3	187/253	28.0	17.3	120.0	72.0	5.9	23.2	27.5	40
	460/60/3	414/506	15.0	9.6	70.0	42.0	3.0	12.6	15.0	20
	575/60/3	517/633	12.5	8.0	53.0	n/a	1.9	9.9	11.9	15

HACR circuit breaker in USA only

\* With optional high-static PSC motor

\*\* With optional IntelliStart™

**NOTE:** High-static option not available on all model sizes.

05/21/13

## Electrical Data cont.

### 5-Speed ECM Motor

Model	Rated Voltage	Voltage Min/Max	Compressor				Blower Motor FLA	Total Unit FLA	Min Circ Amp	Max Fuse/HACR
			MCC	RLA	LRA	LRA**				
015	208-230/60/1	187/253	9.2	5.9	29.0	n/a	4.1	10.0	11.5	15
	265/60/1	238/292	7.8	5.0	28.0	n/a	3.6	8.6	9.9	10/15
018	208-230/60/1	187/253	10.4	6.7	33.5	13.4	4.1	10.8	12.5	15
	265/60/1	238/292	8.7	5.6	28.0	n/a	3.6	9.2	10.6	15
023	208-230/60/1	187/253	21.0	13.5	58.3	23.3	4.1	17.6	21.0	30
	265/60/1	238/292	14.0	9.0	54.0	n/a	3.6	12.6	14.9	20
	208-230/60/3	187/253	11.0	7.1	55.0	33.0	4.1	11.2	13.0	20
	460/60/3	414/506	5.5	3.5	28.0	16.8	2.1	5.6	6.5	10/15
024	208-230/60/1	187/253	21.0	13.5	58.3	23.3	4.1	17.6	21.0	30
	265/60/1	238/292	14.0	9.0	54.0	n/a	3.6	12.6	14.9	20
	208-230/60/3	187/253	11.0	7.1	55.0	33.0	4.1	11.2	13.0	20
	460/60/3	414/506	5.5	3.5	28.0	16.8	2.1	5.6	6.5	10/15
030	208-230/60/1	187/253	22.0	14.1	73.0	29.2	4.1	18.2	21.7	35
	265/60/1	238/292	17.5	11.2	60.0	n/a	3.6	14.8	17.6	25
	208-230/60/3	187/253	13.9	8.9	58.0	34.8	4.1	13.0	15.2	20
	460/60/3	414/506	6.5	4.2	28.0	16.8	2.1	6.3	7.4	10/15
036	208-230/60/1	187/253	27.0	17.3	96.7	38.7	4.1	21.4	25.7	40
	265/60/1	238/292	19.0	12.2	72.0	n/a	3.6	15.8	18.9	30
	208-230/60/3	187/253	20.0	12.8	95.0	57.0	4.1	16.9	20.1	30
	460/60/3	414/506	10.0	6.4	45.0	27.0	2.1	8.5	10.1	15
041	208-230/60/1	187/253	31.0	20.0	115.0	46.0	7.6	27.6	32.6	50
	208-230/60/3	187/253	20.0	12.8	95.0	57.0	7.6	20.4	23.6	30
	460/60/3	414/506	10.0	6.4	45.0	27.0	4.0	10.4	12.0	15
042	208-230/60/1	187/253	31.0	20.0	115.0	46.0	7.6	27.6	32.6	50
	208-230/60/3	187/253	20.0	12.8	95.0	57.0	7.6	20.4	23.6	30
	460/60/3	414/506	10.0	6.4	45.0	27.0	4.0	10.4	12.0	15
048	208-230/60/1	187/253	32.0	21.0	115.0	46.0	7.6	28.6	33.9	50
	208-230/60/3	187/253	25.0	16.0	115.0	69.0	7.6	23.6	27.6	40
	460/60/3	414/506	12.0	7.7	50.0	30.0	4.0	11.7	13.6	20
060	208-230/60/1	187/253	41.0	26.3	150.0	60.0	7.6	33.9	40.5	60
	208-230/60/3	187/253	27.5	17.6	120.0	72.0	7.6	25.2	29.6	45
	460/60/3	414/506	13.0	8.3	70.0	42.0	4.0	12.3	14.4	25
070	208-230/60/1	187/253	47.0	30.1	145.0	58.0	7.6	37.7	45.2	70
	208-230/60/3	187/253	28.0	17.3	120.0	72.0	7.6	24.9	29.2	45
	460/60/3	414/506	15.0	9.6	70.0	42.0	4.0	13.6	16.0	25

HACR circuit breaker in USA only

\*\* With optional IntelliStart™

05/21/13

## Electrical Data cont.

### Variable Speed ECM Motor

Model	Rated Voltage	Voltage Min/Max	Compressor				Blower Motor FLA	Total Unit FLA	Min Circ Amp	Max Fuse/HACR
			MCC	RLA	LRA	LRA**				
015	208-230/60/1	187/253	9.2	5.9	29.0	n/a	4.0	9.9	11.4	15
	265/60/1	238/292	7.8	5.0	28.0	n/a	4.1	9.1	10.3	15
018	208-230/60/1	187/253	10.4	6.7	33.5	13.4	4.0	10.7	12.4	15
	265/60/1	238/292	8.7	5.6	28.0	n/a	4.1	9.7	11.1	15
023	208-230/60/1	187/253	21.0	13.5	58.3	23.3	4.0	17.5	20.9	30
	265/60/1	238/292	14.0	9.0	54.0	n/a	4.1	13.1	15.4	20
	208-230/60/3	187/253	11.0	7.1	55.0	33.0	4.0	11.1	12.9	15
	460/60/3	414/506	5.5	3.5	28.0	16.8	4.1	7.6	8.5	10/15
024	208-230/60/1	187/253	21.0	13.5	58.3	23.3	4.0	17.5	20.9	30
	265/60/1	238/292	14.0	9.0	54.0	n/a	4.1	13.1	15.4	20
	208-230/60/3	187/253	11.0	7.1	55.0	33.0	4.0	11.1	12.9	15
	460/60/3	414/506	5.5	3.5	28.0	16.8	4.1	7.6	8.5	10/15
030	208-230/60/1	187/253	22.0	14.1	73.0	29.2	4.0	18.1	21.6	35
	265/60/1	238/292	17.5	11.2	60.0	n/a	4.1	15.3	18.1	25
	208-230/60/3	187/253	13.9	8.9	58.0	34.8	4.0	12.9	15.1	20
	460/60/3	414/506	6.5	4.2	28.0	16.8	4.1	8.3	9.4	10/15
036	208-230/60/1	187/253	27.0	17.3	96.7	38.7	4.0	21.3	25.6	40
	265/60/1	238/292	19.0	12.2	72.0	n/a	4.1	16.3	19.3	30
	208-230/60/3	187/253	20.0	12.8	95.0	57.0	4.0	16.8	20.0	30
	460/60/3	414/506	10.0	6.4	45.0	27.0	4.1	10.5	12.1	15
041	208-230/60/1	187/253	31.0	20.0	115.0	46.0	4.0	24.0	29.0	45
	208-230/60/3	187/253	20.0	12.8	95.0	57.0	4.0	16.8	20.0	30
	460/60/3	414/506	10.0	6.4	45.0	27.0	4.1	10.5	12.1	15
042	208-230/60/1	187/253	31.0	20.0	115.0	46.0	4.0	24.0	29.0	45
	208-230/60/3	187/253	20.0	12.8	95.0	57.0	4.0	16.8	20.0	30
	460/60/3	414/506	10.0	6.4	45.0	27.0	4.1	10.5	12.1	15
042*	208-230/60/1	187/253	31.0	20.0	115.0	46.0	7.0	27.0	32.0	50
	208-230/60/3	187/253	20.0	12.8	95.0	57.0	7.0	19.8	23.0	35
	460/60/3	414/506	10.0	6.4	45.0	27.0	6.9	13.3	14.9	20
048	208-230/60/1	187/253	32.0	21.0	115.0	46.0	4.0	25.0	30.3	50
	208-230/60/3	187/253	25.0	16.0	115.0	69.0	4.0	20.0	24.0	40
	460/60/3	414/506	12.0	7.7	50.0	30.0	4.1	11.8	13.7	20
048*	208-230/60/1	187/253	32.0	21.0	115.0	46.0	7.0	28.0	33.3	50
	208-230/60/3	187/253	25.0	16.0	115.0	69.0	7.0	23.0	27.0	40
	460/60/3	414/506	12.0	7.7	50.0	30.0	6.9	14.6	16.5	20
060	208-230/60/1	187/253	41.0	26.3	150.0	60.0	7.0	33.3	39.9	60
	208-230/60/3	187/253	27.5	17.6	120.0	72.0	7.0	24.6	29.0	45
	460/60/3	414/506	13.0	8.3	70.0	42.0	6.9	15.2	17.3	25
070	208-230/60/1	187/253	47.0	30.1	145.0	58.0	7.0	37.1	44.6	70
	208-230/60/3	187/253	28.0	17.3	120.0	72.0	7.0	24.9	29.4	45
	460/60/3	414/506	15.0	9.6	70.0	42.0	6.9	16.5	18.9	25

HACR circuit breaker in USA only

\* With optional 1 HP ECM motor

\*\* With optional IntelliStart™

05/21/13



**CAUTION:** When installing a unit with a variable speed ECM blower motor in 460/60/3 voltage, a neutral wire is required to allow proper unit operation.

# Blower Performance Data

## Standard PSC Motor

Model	Blower Spd	Blower Size	Motor hp	Airflow (cfm) at External Static Pressure (in. wg)															
				0	0.05	0.10	0.15	0.20	0.25	0.30	0.35	0.40	0.45	0.50	0.60	0.70	0.80	0.90	1.00
009	H	6 x 8	1/10	530	515	500	485	470	450	430	405	385	355	330	-	-	-	-	-
	MH*			475	460	450	435	420	405	385	365	345	320	300	-	-	-	-	-
	ML*			435	420	410	395	380	365	345	325	300	-	-	-	-	-	-	-
	L			370	355	340	325	310	290	275	-	-	-	-	-	-	-	-	-
012	H	6 x 8	1/10	530	515	500	485	470	450	430	405	385	355	330	-	-	-	-	-
	MH*			475	460	450	435	420	405	385	365	345	320	300	-	-	-	-	-
	ML			435	420	410	395	380	365	345	325	300	-	-	-	-	-	-	-
	L			370	355	340	325	310	290	275	-	-	-	-	-	-	-	-	-
015	H	9 x 7	1/6	875	860	845	830	820	805	790	770	750	725	700	-	-	-	-	-
	M			760	750	740	730	720	710	700	680	660	640	620	-	-	-	-	-
	L			630	620	610	600	590	580	570	560	550	520	490	-	-	-	-	-
018	H	9 x 7	1/6	875	860	845	830	820	805	790	770	750	725	700	-	-	-	-	-
	M			760	750	740	730	720	710	700	680	660	640	620	-	-	-	-	-
	L			630	620	610	600	590	580	570	560	550	520	490	-	-	-	-	-
023	H	9 x 7	1/5	1020	990	960	930	900	870	850	830	800	770	690	-	-	-	-	-
	M			960	840	820	800	780	760	740	720	690	670	-	-	-	-	-	-
	L			720	700	680	650	640	620	600	580	570	550	-	-	-	-	-	-
024	H	9 x 7	1/5	1065	1045	1030	1005	975	950	925	900	870	835	800	-	-	-	-	-
	M			880	865	850	830	815	795	775	750	725	700	670	-	-	-	-	-
	L			805	790	780	765	745	725	710	685	660	630	600	-	-	-	-	-
030	H	9 x 7	1/3	1240	1220	1200	1175	1150	1110	1080	1055	1030	975	920	840	730	-	-	-
	M			1095	1085	1080	1060	1045	1020	995	960	925	885	850	785	675	-	-	-
	L			860	860	855	850	850	845	845	825	805	775	750	680	-	-	-	-
036	H	9 x 7	1/2	1360	1340	1320	1290	1260	1220	1185	1130	1080	1045	1010	910	855	-	-	-
	M			1205	1190	1170	1145	1120	1085	1050	1015	980	940	900	845	-	-	-	-
	L			1070	1060	1050	1035	1020	995	970	940	910	875	840	780	-	-	-	-
041	H	10x10	1/2	1655	1635	1615	1590	1570	1535	1500	1425	1350	1270	1185	1080	970	-	-	-
	M			1470	1455	1445	1425	1410	1380	1350	1285	1240	1205	1170	905	-	-	-	-
	L			1150	1140	1130	1110	1090	1050	1010	970	930	900	865	800	-	-	-	-
042	H	10 x 10	1/2	1705	1685	1665	1645	1625	1595	1565	1530	1500	1450	1405	1260	1140	-	-	-
	M			1485	1475	1465	1445	1430	1410	1390	1350	1315	1260	1210	1110	1010	-	-	-
	L			1180	1165	1150	1135	1120	1090	1060	1030	1000	965	920	855	-	-	-	-
048	H	10 x 10	1/2	1930	1910	1885	1860	1830	1790	1750	1710	1665	1620	1580	1280	1235	-	-	-
	M			1580	1565	1550	1535	1525	1505	1485	1445	1410	1310	1215	1130	1030	-	-	-
	L			1180	1170	1160	1140	1120	1100	1080	1050	1020	970	930	875	-	-	-	-
060	H	11 x 10	1	2360	2330	2300	2270	2240	2215	2190	2160	2130	2095	2060	1985	1920	1855	-	-
	M			2165	2130	2095	2070	2050	2030	2010	1985	1965	1930	1900	1850	1775	1700	-	-
	L			1965	1940	1920	1900	1885	1870	1855	1825	1800	1780	1760	1720	1625	1530	-	-
070	H	11 x 10	1	2450	2435	2420	2395	2370	2340	2310	2280	2250	2225	2200	2040	2000	1950	-	-
	M			2215	2190	2170	2155	2140	2120	2095	2070	2045	2015	1990	1940	1876	1795	-	-
	L			2005	1990	1975	1960	1950	1940	1925	1910	1890	1865	1845	1780	1710	1565	-	-

7/6/10

### Factory settings are in Bold

Airflow values are with dry coil and standard filter

For wet coil performance first calculate the face velocity of the air coil (Face Velocity [fpm] = Airflow [cfm] / Face Area [sq ft]).

Then for velocities of 200 fpm reduce the static capability by 0.03 in. wg, 300 fpm by 0.08 in. wg, 400 fpm by 0.12in. wg. and 500 fpm by 0.16 in. wg.

## Optional High Static PSC Motor

Model	Blower Spd	Blower Size	Motor hp	Airflow (cfm) at External Static Pressure (in. wg)															
				0	0.05	0.10	0.15	0.20	0.25	0.30	0.35	0.40	0.45	0.50	0.60	0.70	0.80	0.90	1.00
024	H	9 x 7	1/3	1240	1220	1200	1175	1150	1110	1080	1055	1030	975	920	840	730	-	-	-
	M			1095	1085	1080	1060	1045	1020	995	960	925	885	850	785	675	-	-	-
	L			860	860	855	850	850	845	845	825	805	775	750	680	-	-	-	-
030	H	9 x 7	1/2	1340	1320	1300	1270	1240	1200	1160	1115	1070	1025	985	880	-	-	-	-
	M			1185	1175	1165	1130	1095	1065	1035	1000	965	920	880	795	-	-	-	-
	L			1050	1040	1030	1015	1000	980	960	925	895	855	815	-	-	-	-	-
042	H	10 x 10	3/4	2095	2080	2060	2020	1980	1950	1920	1880	1840	1780	1725	1550	1335	1120	-	-
	M			1960	1940	1920	1890	1865	1830	1800	1760	1725	1670	1620	1435	1300	-	-	-
	L			1800	1780	1760	1740	1725	1695	1670	1625	1585	1525	1465	1300	1200	-	-	-
048	H	10 x 10	3/4	2095	2080	2060	2020	1980	1950	1920	1880	1840	1780	1725	1550	1335	1120	-	-
	M			1960	1940	1920	1890	1865	1830	1800	1760	1725	1670	1620	1435	1300	-	-	-
	L			1800	1780	1760	1740	1725	1695	1670	1625	1585	1525	1465	1300	1200	-	-	-

7/6/10

### Factory settings are in Bold

Airflow values are with dry coil and standard filter

For wet coil performance first calculate the face velocity of the air coil (Face Velocity [fpm] = Airflow [cfm] / Face Area [sq ft]).

Then for velocities of 200 fpm reduce the static capability by 0.03 in. wg, 300 fpm by 0.08 in. wg, 400 fpm by 0.12in. wg. and 500 fpm by 0.16 in. wg.

\* Setting for 265 V operation.

# Setting Blower Speed - PSC



**CAUTION:** Disconnect all power before performing this operation.

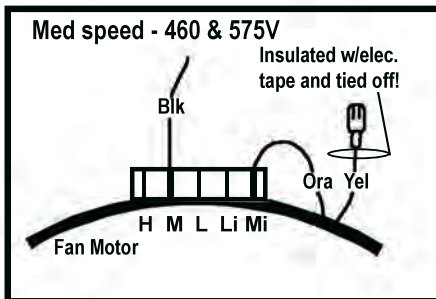
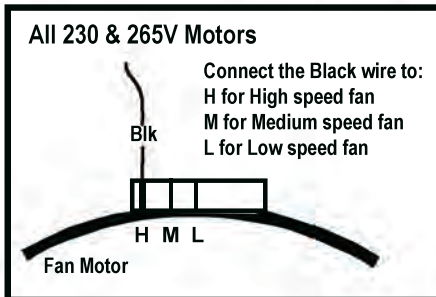
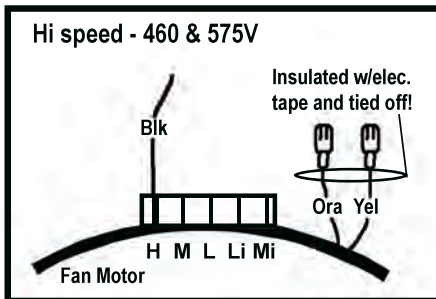
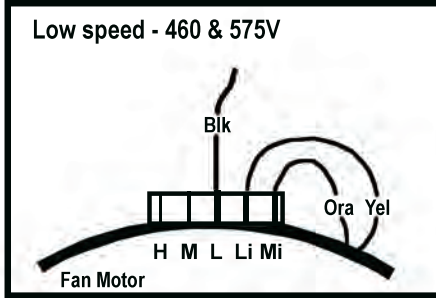
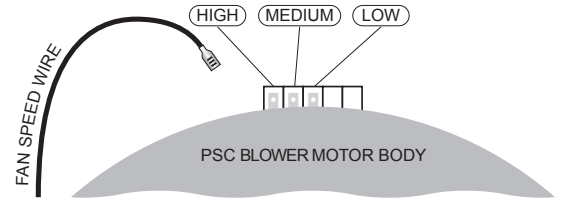

# Blower Performance Data cont.

## 5-Speed ECM Motor

Model	Motor Speed	Motor Tap	Blower Size	Motor HP	Airflow (cfm) at External Static Pressure (in. wg)															
					0	0.05	0.10	0.15	0.20	0.25	0.30	0.35	0.40	0.45	0.50	0.60	0.70	0.80	0.90	1.00
015	High	5	9 x 7	1/2	915	895	880	865	850	830	815	805	795	775	750	730	695	640	-	-
	Med High	4			805	785	765	750	740	725	705	685	665	655	635	605	535	-	-	-
	Med	3			725	715	700	680	660	635	615	600	585	560	535	485	-	-	-	-
	Med Low	2			695	675	650	630	610	590	575	550	525	490	455	-	-	-	-	-
	Low	1			655	600	550	530	508	490	475	435	395	350	-	-	-	-	-	-
018	High	5	9 x 7	1/2	915	895	880	865	850	830	815	805	795	775	750	730	695	640	-	-
	Med High	4			805	785	765	750	740	725	705	685	665	655	635	605	535	-	-	-
	Med	3			725	715	700	680	660	635	615	600	585	560	535	485	-	-	-	-
	Med Low	2			695	675	650	630	610	590	575	550	525	490	455	-	-	-	-	-
	Low	1			655	600	550	530	508	490	475	435	395	350	-	-	-	-	-	-
023	High	5	9 x 7	1/2	980	960	940	930	920	905	890	875	860	840	820	800	745	-	-	
	Med High	4			890	878	865	845	825	813	800	785	770	753	735	710	665	-	-	-
	Med	3			830	815	800	788	775	755	735	723	710	690	670	640	600	-	-	-
	Med Low	2			780	760	740	703	665	653	640	620	600	585	570	-	-	-	-	-
	Low	1			625	593	560	535	510	495	480	455	430	410	390	-	-	-	-	-
024	High	5	9 x 7	1/2	980	960	940	930	920	905	890	875	860	840	820	800	745	-	-	
	Med High	4			890	878	865	845	825	813	800	785	770	753	735	710	665	-	-	-
	Med	3			830	815	800	788	775	755	735	723	710	690	670	640	600	-	-	-
	Med Low	2			780	760	740	703	665	653	640	620	600	585	570	-	-	-	-	-
	Low	1			625	593	560	535	510	495	480	455	430	410	390	-	-	-	-	-
030	High	5	9 x 7	1/2	1340	1310	1280	1240	1200	1170	1140	1095	1050	1015	980	900	800	-	-	
	Med High	4			1130	1115	1100	1085	1070	1057	1044	1022	1000	970	940	870	780	-	-	-
	Med	3			1030	1005	980	965	950	935	920	900	880	870	860	830	750	-	-	-
	Med Low	2			960	945	930	915	900	885	870	855	840	825	810	790	740	-	-	-
	Low	1			790	765	740	725	710	690	670	660	650	630	610	580	500	-	-	-
036	High	5	9 x 7	1/2	1370	1345	1320	1285	1250	1220	1190	1158	1125	1085	1045	960	-	-	-	
	Med High	4			1265	1253	1240	1220	1200	1175	1150	1120	1090	1053	1015	-	-	-	-	
	Med	3			1160	1143	1125	1113	1100	1085	1070	1055	1040	1020	1000	-	-	-	-	
	Med Low	2			1110	1095	1080	1065	1050	1038	1025	1008	990	980	970	-	-	-	-	
	Low	1			825	803	780	770	760	740	720	705	690	670	650	-	-	-	-	
041	High	5	11 x 10	1	1840	1825	1810	1790	1770	1745	1720	1700	1680	1660	1640	1600	1570	1530	1480	-
	Med High	4			1730	1713	1695	1670	1645	1623	1600	1575	1550	1535	1520	1480	1440	1390	1350	-
	Med	3			1630	1610	1590	1563	1535	1513	1490	1470	1450	1425	1400	1370	1330	1290	-	-
	Med Low	2			1550	1520	1490	1465	1440	1415	1390	1370	1350	1330	1310	1260	1220	1180	-	-
	Low	1			1380	1340	1300	1275	1250	1225	1200	1175	1150	1125	1100	1030	980	820	-	-
042	High	5	11 x 10	1	1840	1825	1810	1790	1770	1745	1720	1700	1680	1660	1640	1600	1570	1530	1480	-
	Med High	4			1730	1713	1695	1670	1645	1623	1600	1575	1550	1535	1520	1480	1440	1390	1350	-
	Med	3			1630	1610	1590	1563	1535	1513	1490	1470	1450	1425	1400	1370	1330	1290	-	-
	Med Low	2			1550	1520	1490	1465	1440	1415	1390	1370	1350	1330	1310	1260	1220	1180	-	-
	Low	1			1380	1340	1300	1275	1250	1225	1200	1175	1150	1125	1100	1030	980	820	-	-
048	High	5	11 x 10	1	2060	2045	2030	2015	2000	1970	1940	1925	1910	1890	1870	1830	1800	1750	1740	-
	Med High	4			1880	1860	1840	1825	1810	1785	1760	1740	1720	1705	1690	1640	1610	1570	1535	-
	Med	3			1790	1770	1750	1730	1710	1685	1660	1640	1620	1600	1580	1550	1510	1460	-	-
	Med Low	2			1670	1650	1630	1605	1580	1555	1530	1510	1490	1470	1450	1410	1370	1340	-	-
	Low	1			1430	1405	1380	1353	1325	1303	1280	1255	1230	1210	1190	1130	1070	925	-	-
060	High	5	11 x 10	1	2400	2360	2330	2315	2300	2290	2285	2275	2265	2250	2230	2200	2165	2110	2080	2030
	Med High	4			2180	2160	2140	2130	2120	2105	2090	2075	2060	2045	2030	2000	1960	1930	1890	1850
	Med	3			2080	2050	2020	2010	2000	1985	1970	1955	1940	1925	1910	1870	1840	1800	1760	1720
	Med Low	2			1930	1920	1910	1893	1875	1863	1850	1833	1815	1798	1780	1740	1700	1660	1620	1590
	Low	1			1750	1735	1720	1698	1675	1658	1640	1620	1600	1583	1565	1525	1490	1450	1410	1350
070	High	5	11 x 10	1	2400	2360	2330	2315	2300	2290	2285	2275	2265	2250	2230	2200	2165	2110	2080	2030
	Med High	4			2180	2160	2140	2130	2120	2105	2090	2075	2060	2045	2030	2000	1960	1930	1890	1850
	Med	3			2080	2050	2020	2010	2000	1985	1970	1955	1940	1925	1910	1870	1840	1800	1760	1720
	Med Low	2			1930	1920	1910	1893	1875	1863	1850	1833	1815	1798	1780	1740	1700	1660	1620	1590
	Low	1			1750	1735	1720	1698	1675	1658	1640	1620	1600	1583	1565	1525	1490	1450	1410	1350

01/23/13

**Factory settings are in Bold**

Airflow values are with dry coil and standard 1 in. filter

ISO/AHRI rating point on the US\*070 will require moving the red wire on the motor to high speed (tap 5) and disconnecting the tan wire from tap 5.

### Setting Blower Speed - 5-Speed ECM

5-speed ECM blower motors have five (5) speeds of which three (3) are selectable on single speed and four (4) are selectable on dual capacity.

### 5-Speed ECM Motor Connections

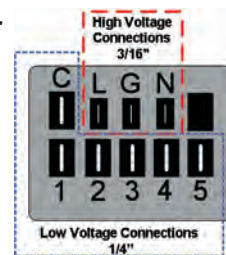

**CAUTION: Disconnect all power before performing this operation.**



## 5-Speed ECM Constant Torque Motors

The 5-speed ECM is a 'Constant Torque' ECM motor and delivers air flow similar to a PSC but operates as efficiently as an variable speed ECM motor. Because it's an ECM Motor, the 5-speed ECM can ramp slowly up or down like the variable speed ECM motor. There are 5 possible speed taps available on the 5-speed motor with #1 being the lowest airflow and #5 being the highest airflow. These speed selections are preset at the time of manufacture and are easily changed in the field if necessary.

### 5-Speed ECM Benefits:

- High efficiency
- Soft start
- 5 speeds with up to 4 speeds on-line
- Built in logic allows air flow to change with G, Y1, Y2 and W signals
- Super efficient low airflow continuous blower setting (G)

If more than one tap are energized at the same time, built in logic gives precedence to the highest tap number and allows air flow to change with G, Y1, Y2 and W signals. Each of those 5 speeds has a specific 'Torque' value programmed into the motor for each speed selection. As static pressure increases, airflow decreases resulting in less torque on the rotor. The motor responds only to changes in torque and adjusts its speed accordingly.

The 5-speed motor is powered by line voltage but the motor speed is energized by 24VAC.

Power Connection - 3/16 in. quick connects - Line 1 (orange wire) to L, Ground (green wire) to G, Line 2 (for 208V-230V units) to N (brown wire).

Signal Connection - 1/4 in. quick connects - Common to C, 24VAC to Taps #1-5.

Applying 24VAC power between any of the motor taps 1-5 (1/4 in. quick connects) and common will signal the motor to run and regulate torque at the programmed level. The tap input voltage must be in the range 12-33VAC. The 5-speed ECM will have less variation over the operating static pressure range versus a PSC motor as well as a significant watts reduction due to the high motor efficiency.

Thermal Protection - Motor is electronically protected.

Locked Rotor Amps - If motor speed decreases below a programmed stall speed, the motor will shut down and after a delay period, the control will attempt to restart the motor.

The 5-speed ECM speed tap selections are as follows:

The blue wire should be placed on the speed tap desired for the (G) continuous blower setting – factory wired to Tap 1.

The red wire should be placed on the speed tap desired during compressor operation (Y1 signal) – factory wired to Tap 3 or 4.

The gray wire is not factory wired to the motor and is tied to the wire harness. It is field connected and can be used with 3ht/2cl thermostats or IntelliZone to deliver the required air flow for the Y2 signal.

The tan wire should be placed on the speed tap desired for auxiliary heat (W signal) – factory wired to Tap 5.

## Blower Performance Data cont.

### Variable Speed ECM Motor

Model	Max esp	Airflow DIP Switch Settings											
		1	2	3	4	5	6	7	8	9	10	11	12
015	0.50	300 L	400	500 M	600 H	700							
018	0.50	300	400 L	500	600 M	700 H	800						
023	0.50		400	500 L	600 M	700	800 H	900	1000	1100	1200		
024	0.50		400	500 L	600 M	700	800 H	900	1000	1100	1200		
030	0.50		400	500 L	600	700 M	800	900 H	1000	1100	1200		
036	0.50				600	700 L	800	900 M	1000	1100 H	1150	1225	1300
041	0.50	650	750	850 L	950	1050 M	1150	1250	1325 H	1375	1475	1550	1600
042	0.50	650	750	850 L	950	1050 M	1150	1250	1325 H	1375	1475	1550	1600
042 w/1hp*	0.75	800 L	1000 M	1100	1300 H	1500	1600	1800					
048	0.50	650	750	850	950	1050 L	1150	1250 M	1325	1375	1475	1550 H	1600
048 w/1hp*	0.75	800	1000 L	1100	1300 M	1500 H	1600	1800					
060	0.75	750	900	1000	1200 L	1400 M	1600	1700	1850 H	2000	2200	2300	2400
070	0.75	800	950	1100 L	1300	1500	1750 M	1950	2100 H	2300			

11/10/09

Factory settings are at recommended L-M-H DIP switch locations.

Shaded regions are recommended for best performance. It is acceptable to operate outside of this area as long as the WSHP operates within the guidelines of the Operating Limits table and Correction Factor tables.

Lowest and Highest DIP switch settings are assumed to be L and H respectively.

CFM is controlled within ±5% up to the maximum esp.

Max esp includes allowance for wet coil and standard filter

## Blower Performance Data cont.

### Setting Blower Speed - Variable Speed ECM

The ABC board's Yellow Config LED will flash the current variable speed ECM blower speed selections for low, med, and high continuously with a short pause in between. The speeds can also be confirmed with the AID Tool under the Setup/ECM Setup screen. The variable speed ECM blower motor speeds can be field adjusted with or without using an AID Tool.

### Variable Speed ECM Setup without an AID Tool

The blower speeds for Low (G only), Med (Y1), and High (Y2/Aux) can be adjusted directly at the Aurora ABC board which utilizes the push button (SW1) on the ABC board. This procedure is outlined in the Variable Speed ECM Configuration Mode portion of the Aurora 'Base' Control System section.

### Variable Speed ECM Setup with an AID Tool

A much easier method utilizes the AID Tool to change the airflow using the procedure below. First navigate to the Setup screen and then select ECM Setup. This screen displays the current variable speed ECM settings. It allows the technician to enter the setup screens to change the variable speed ECM settings. Change the highlighted item using the ◀ and ▶ buttons and then press the ◻ button to select the item.

### Variable Speed ECM Setup with an AID Tool cont.

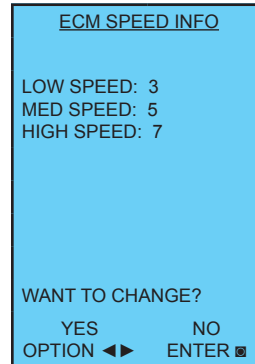

Selecting YES will enter variable speed ECM speed setup, while selecting NO will return to the previous screen.

### Variable Speed ECM Speed Setup

- These screens allow the technician to select the low, medium, and high blower speed for the variable speed ECM blower motor. Change the highlighted item using the ▲ and ▼ buttons. Press the ◻ button to select the speed.

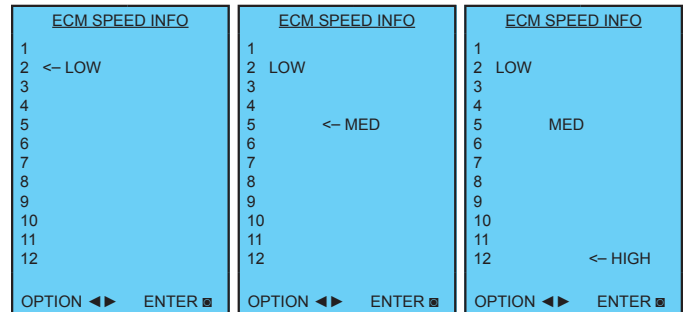

After the high speed setting is selected the AID Tool will automatically transfer back to the ECM Setup screen.

# Wiring Schematics

## Commercial Aurora with PSC Motor & Soft Start 208-230/60/1

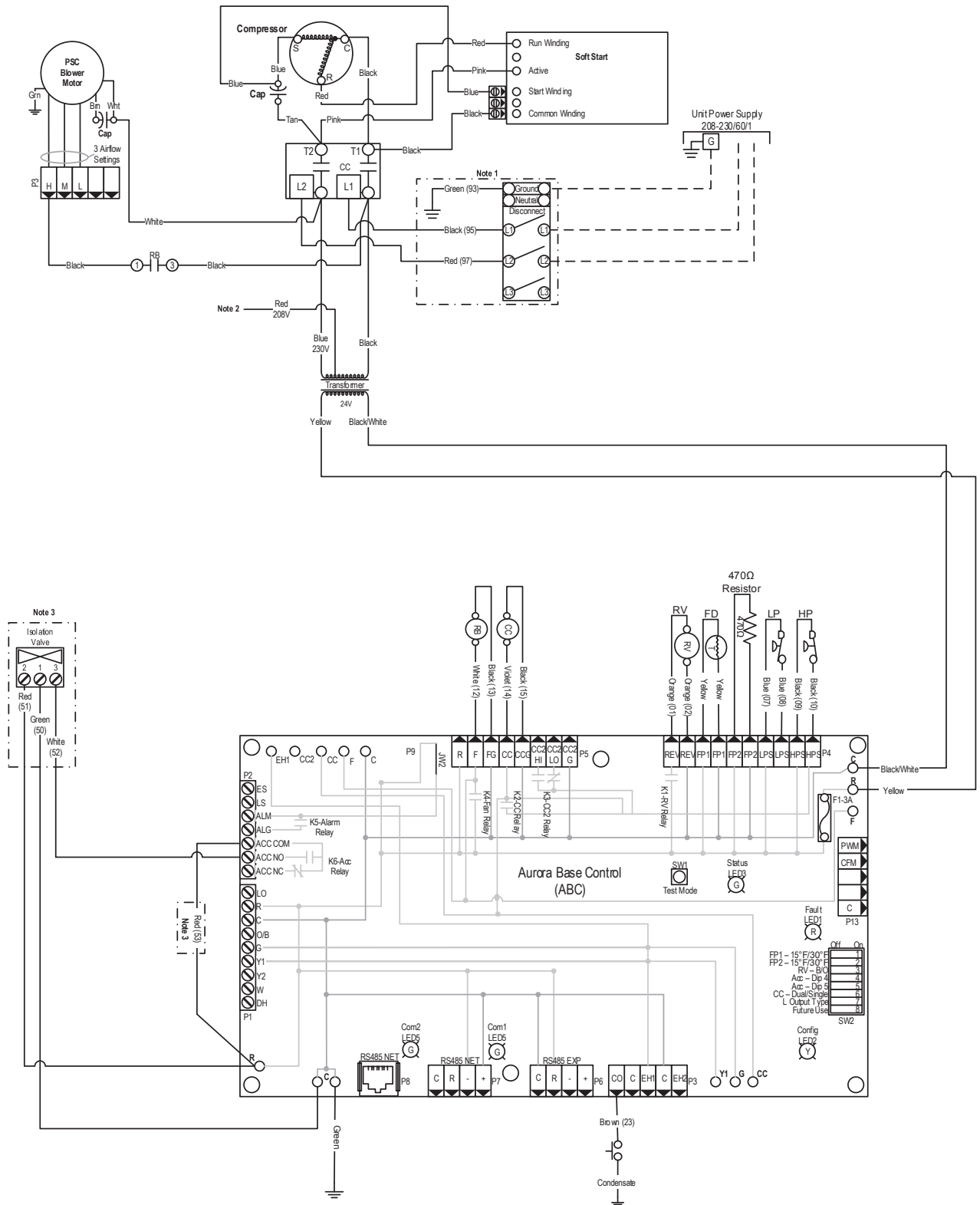

# Wiring Schematics cont.

## Commercial Aurora with PSC Motor & Soft Start 208-230/60/1

### Notes:

- 1 – Optional, factory installed unit mounted disconnect.
- 2 – Swap blue and red leads for 208V operation.
- 3 – Optional, factory installed internal isolation valve.

### Legend

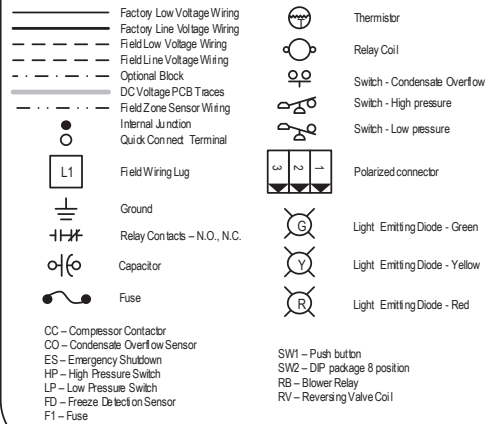

Aurora LED Flash Codes					
<b>Slow Flash</b>	1 second on and 1 second off				
<b>Fast Flash</b>	100 milliseconds on and 100 milliseconds off				
<b>Flash Code</b>	100 milliseconds on and 400 milliseconds off with a 2 second pause before repeating				
<b>Random Start Delay</b>					
Status LED (LED1, Green)	Fast Flash				
Configuration LED (LED2, Yellow)	Fast Flash				
Fault LED (LED3, Red)	Fast Flash				
Status LED (LED1, Green)		Configuration LED (LED2, Yellow)		Fault LED (LED3, Red)	
Normal Mode	ON	No Software Override	Flash ECM Setting	Normal Mode	OFF
Control is Non-Functional	OFF	DIP Switch Override	Slow Flash	Input Fault Lockout	Flash Code 1
Test Mode	Slow Flash	ECM Configure Mode	Fast Flash	High Pressure Lockout	Flash Code 2
Lockout Active	Fast Flash	Reset Configure Mode	Off	Low Pressure Lockout	Flash Code 3
Dehumidification Mode	Flash Code 2			Low Air Coil Limit Lockout - FP2	Flash Code 4
Resensed	Flash Code 3			Low Water Coil Limit Lockout - FP1	Flash Code 5
Resensed	Flash Code 4			Resensed	Flash Code 6
Load Shed	Flash Code 5			Condensate Overflow Lockout	Flash Code 7
ESD	Flash Code 6			Over/Under Voltage Shutdown	Flash Code 8
Resensed	Flash Code 7			Resensed	Flash Code 9
				Resensed	Flash Code 10
				Air/Water Coil Limit Sensor Error	Flash Code 11

Aurora Timing Events		
Event	Normal Mode	Test Mode
Random Start Delay	5 to 80 seconds	1 second
Compressor On Delay	5 seconds	< 1 second
Compressor Minimum On Time	2 minutes	5 seconds
Compressor Short Cycle Delay	4 minutes	15 seconds
Blower Off Delay	30 seconds	2 seconds
Fault Recognition Delay – High Pressure	Less than 1 second	Less than 1 second
Start-Up Bypass – Low Pressure	2 minutes	30 seconds
Fault Recognition Delay – Low Pressure	30 seconds	30 seconds
Start-Up Bypass – Low Water/Air Coil Limit	2 minutes	30 seconds
Fault Recognition Delay – Low Water/Air Coil Limit	30 seconds	30 seconds
Fault Recognition Delay – Condensate Overflow	30 seconds	30 seconds
Thermostat Call Recognition Time	2 seconds	2 seconds
Auxiliary Heat Stop on Delay	5 minutes	20 seconds
Emergency Heat Stop on Delay	2 minutes	7.5 seconds
Water Valve Slow Open Delay	90 seconds	90 seconds
Reheat Delay	30 seconds	30 seconds

Accessory Relay		
Operation	SW2-4	SW2-5
Cycle with Blower	On	On
Cycle with Compressor	Off	Off
Water Valve Slow Open	On	Off
Outdoor Air Damper	Off	On

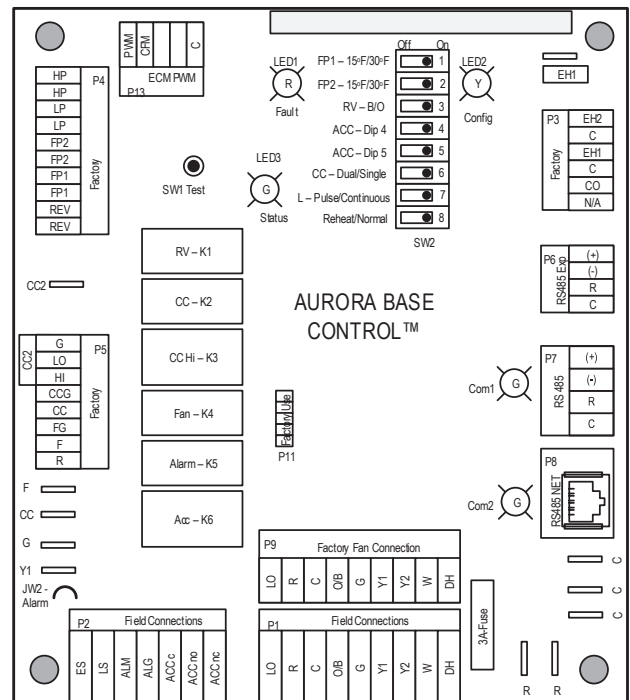

# Wiring Schematics cont.

## Commercial Aurora VS ECM Motor & Hot Gas Reheat - 460/60/3

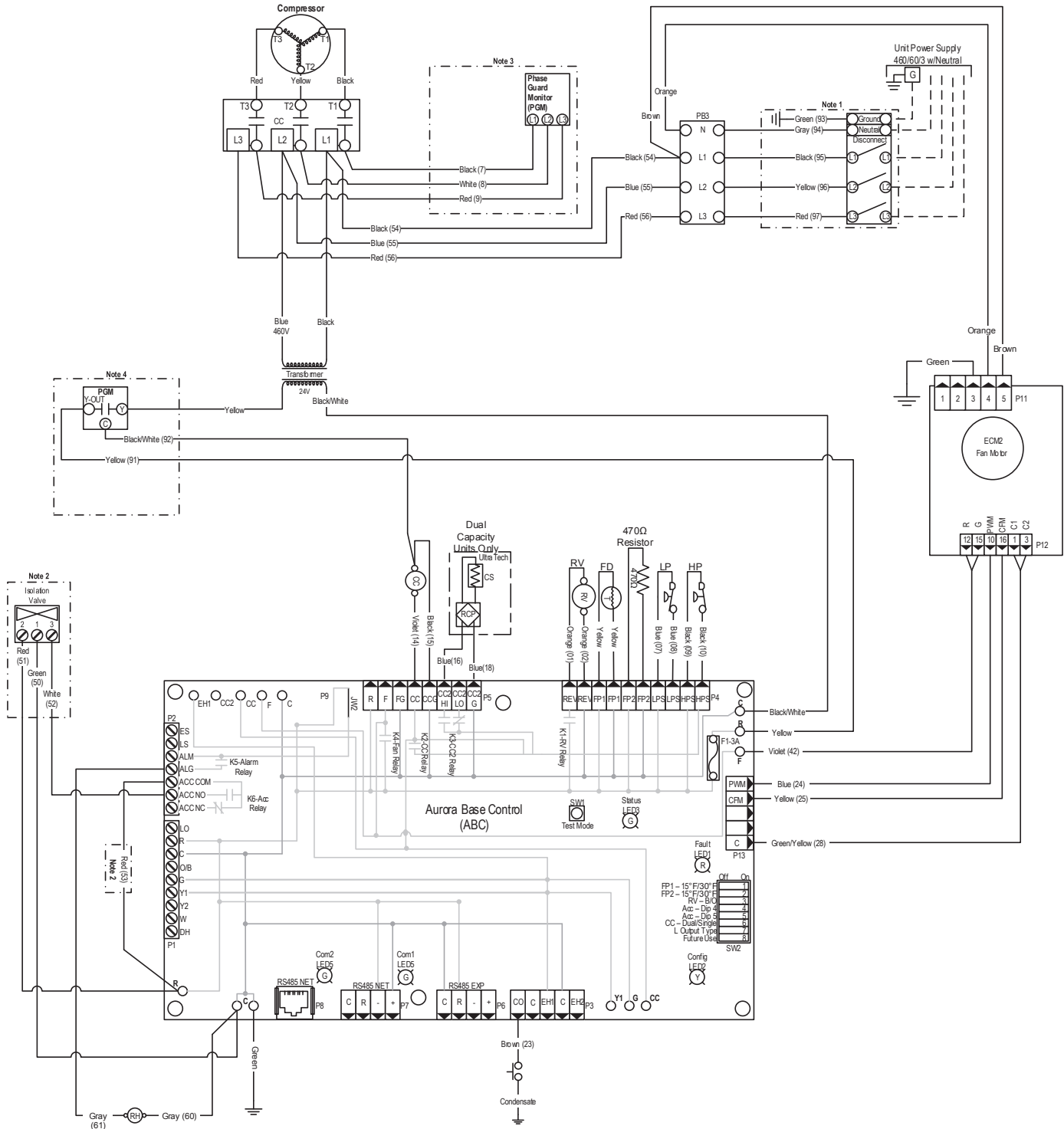

# Wiring Schematics cont.

## Commercial Aurora VS ECM Motor & Hot Gas Reheat - 460/60/3

**Notes:**

- 1 - Optional, factory installed unit mounted disconnect.
- 2 - Optional, factory installed internal isolation valve.
- 3 - Optional, factory installed phase guard
- 4 - Optional, factory installed phase guard. The yellow transformer wire shall be connected directly to the CPU board, if this option is not installed.

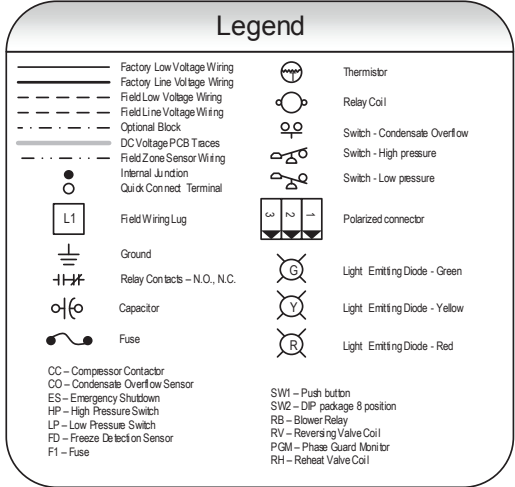

**Aurora LED Flash Codes**

<b>Slow Flash</b>	1 second on and 1 second off				
<b>Fast Flash</b>	100 milliseconds on and 100 milliseconds off				
<b>Flash Code</b>	100 milliseconds on and 400 milliseconds off with a 2 second pause before repeating				
<b>Random Start Delay</b>					
Status LED (LED1, Green)	Fast Flash				
Configuration LED (LED2, Yellow)	Fast Flash				
Fault LED (LED3, Red)	Fast Flash				
<b>Status LED (LED1, Green)</b>	<b>Configuration LED (LED2, Yellow)</b>	<b>Fault LED (LED3, Red)</b>			
Normal Mode	ON	No Software Override	Flash EQM Setting	Normal Mode	OFF
Control is Non-Functional	OFF	DIP Switch Override	Slow Flash	Input Fault Lockout	Flash Code 1
Test Mode	Slow Flash	ECM Configure Mode	Fast Flash	High Pressure Lockout	Flash Code 2
Lockout Active	Fast Flash	Reset Configure Mode	Off	Low Pressure Lockout	Flash Code 3
Dehumidification Mode	Flash Code 2			Low Air Coil Limit Lockout - FP2	Flash Code 4
Reserved	Flash Code 3			Low Water Coil Limit Lockout - FP1	Flash Code 5
Reserved	Flash Code 4			Reserved	Flash Code 6
Load Shed	Flash Code 5			Condensate Overflow Lockout	Flash Code 7
ESD	Flash Code 6			Over/Under Voltage Shutdown	Flash Code 8
Reserved	Flash Code 7			Reserved	Flash Code 9
				Reserved	Flash Code 10
				Reserved	Flash Code 11

**Accessory Relay**

Operation	SW2-4	SW2-5
Cycle with Blower	On	On
Cycle with Compressor	Off	Off
Water Valve Slow Open	On	Off
Outdoor Air Damper	Off	On

**Aurora Timing Events**

Event	Normal Mode	Test Mode
Random Start Delay	5 to 80 seconds	1 second
Compressor On Delay	5 seconds	< 1 second
Compressor Minimum On Time	2 minutes	5 seconds
Compressor Short Cycle Delay	4 minutes	15 seconds
Blower Off Delay	30 seconds	2 seconds
Fault Recognition Delay - High Pressure	Less than 1 second	Less than 1 second
Start-Up Bypass - Low Pressure	2 minutes	30 seconds
Fault Recognition Delay - Low Pressure	30 seconds	30 seconds
Start-Up Bypass - Low Water/Air Coil Limit	2 minutes	30 seconds
Fault Recognition Delay - Low Water/Air Coil Limit	30 seconds	30 seconds
Fault Recognition Delay - Condensate Overflow	30 seconds	30 seconds
Thermostat Call Recognition Time	2 seconds	2 seconds
Auxiliary Heat Staging Delay	5 minutes	20 seconds
Emergency Heat Staging Delay	2 minutes	7.5 seconds
Water Valve Slow Open Delay	90 seconds	90 seconds
Reheat Delay	30 seconds	30 seconds

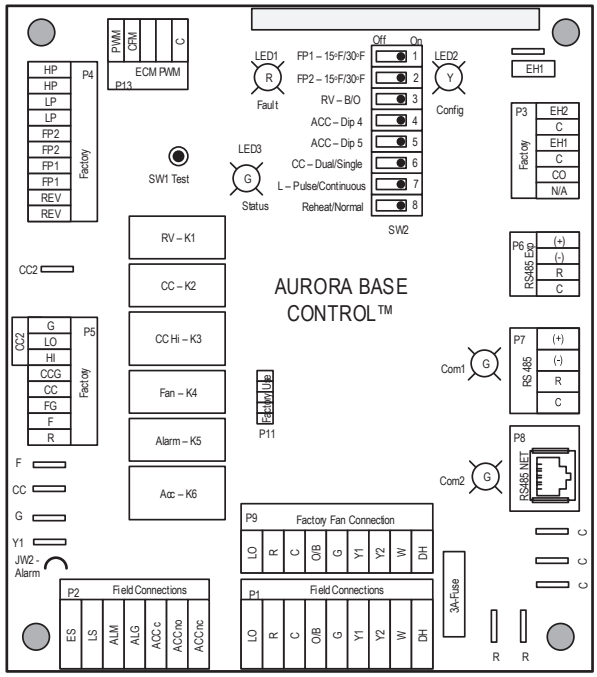

# Wiring Schematics cont.

## Commercial Aurora with VS ECM Motor 208-230-265/60/1

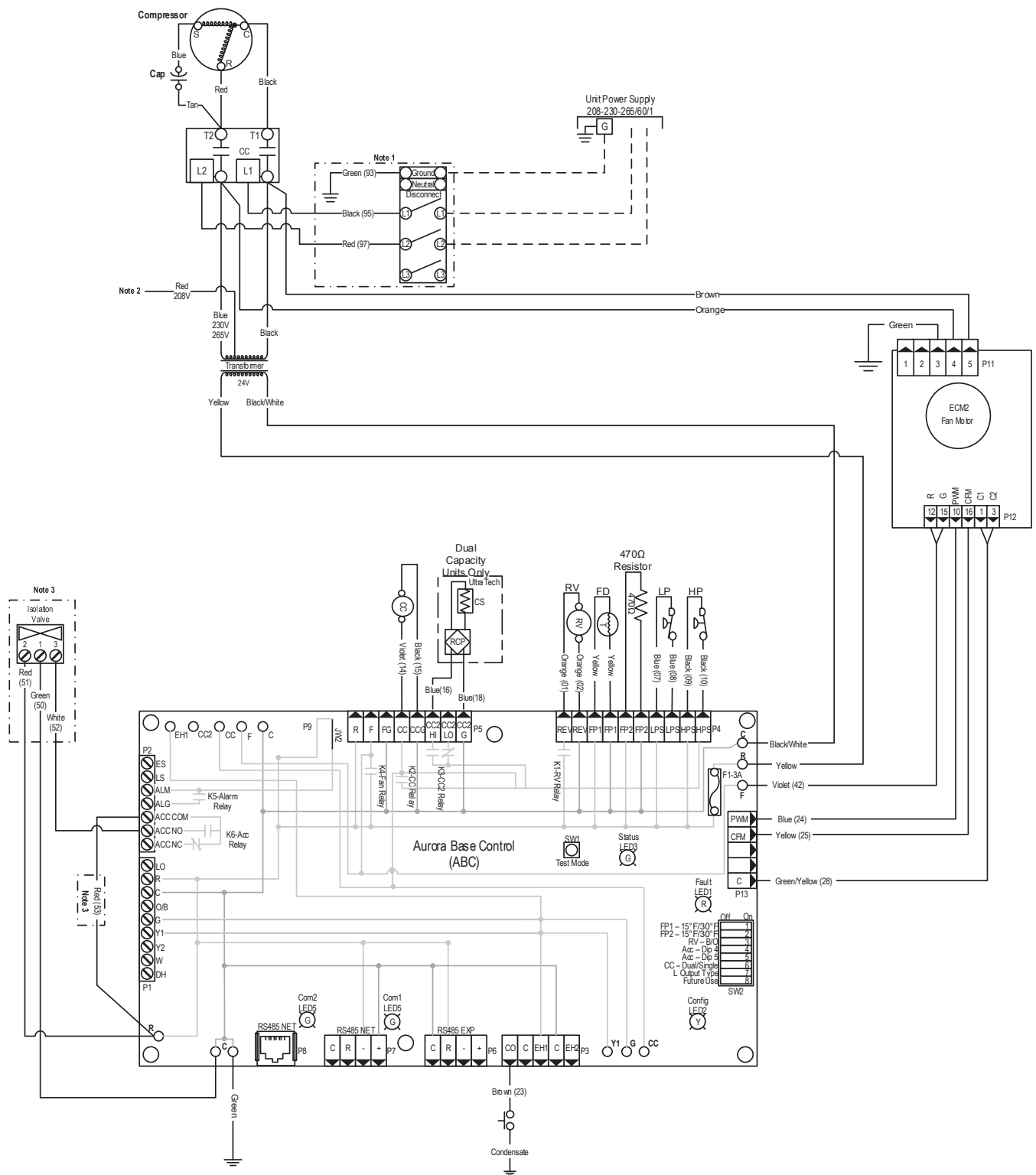



# Wiring Schematics cont.

## Commercial Aurora with VS ECM Motor 208-230-265/60/1

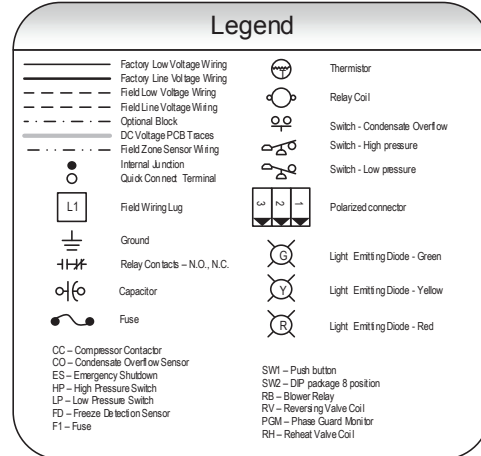

Aurora LED Flash Codes					
<b>Slow Flash</b>	1 second on and 1 second off				
<b>Fast Flash</b>	100 milliseconds on and 100 milliseconds off				
<b>Flash Code</b>	100 milliseconds on and 400 milliseconds off with a 2 second pause before repeating				
<b>Random Start Delay</b>					
Status LED (LED1, Green)	Fast Flash				
Configuration LED (LED2, Yellow)	Fast Flash				
Fault LED (LED3, Red)	Fast Flash				
<b>Status LED (LED1, Green)</b>		<b>Configuration LED (LED2, Yellow)</b>		<b>Fault LED (LED3, Red)</b>	
Normal Mode	ON	No Software Override	Flash ECM Setting	Normal Mode	OFF
Control is Non-Functional	OFF	DIP Switch Override	Slow Flash	Input Fault Lockout	Flash Code 1
Test Mode	Slow Flash	ECM Configure Mode	Fast Flash	High Pressure Lockout	Flash Code 2
Lockout Active	Fast Flash	Reset Configure Mode	Off	Low Pressure Lockout	Flash Code 3
Dehumidification Mode	Flash Code 2			Low Air Coil Limit Lockout - FP2	Flash Code 4
Reserved	Flash Code 3			Low Water Coil Limit Lockout - FP1	Flash Code 5
Reserved	Flash Code 4			Reserved	Flash Code 6
Load Shed	Flash Code 5			Condensate Overflow Lockout	Flash Code 7
ESD	Flash Code 6			Over/Under Voltage Shutdown	Flash Code 8
Reserved	Flash Code 7			Reserved	Flash Code 9
				Reserved	Flash Code 10
				Air/Water Coil Limit Sensor Error	Flash Code 11

**Notes:**

- 1 - Optional, factory installed unit mounted disconnect.
- 2 - Swap blue and red leads for 208V operation.
- 3 - Optional, factory installed internal isolation valve.

Accessory Relay			
Operation	SW2-4	SW2-5	
Cycle with Blower	On	On	
Cycle with Compressor	Off	Off	
Water Valve Slow Open	On	Off	
Outdoor Air Damper	Off	On	

  

Aurora Timing Events		
Event	Normal Mode	Test Mode
Random Start Delay	5 to 80 seconds	1 second
Compressor On Delay	5 seconds	< 1 second
Compressor Minimum On Time	2 minutes	5 seconds
Compressor Short Cycle Delay	4 minutes	15 seconds
Blower Off Delay	30 seconds	2 seconds
Fault Recognition Delay - High Pressure	Less than 1 second	Less than 1 second
Start-Up Bypass - Low Pressure	2 minutes	30 seconds
Fault Recognition Delay - Low Pressure	30 seconds	30 seconds
Start-Up Bypass - Low Water/Air Coil Limit	2 minutes	30 seconds
Fault Recognition Delay - Low Water/Air Coil Limit	30 seconds	30 seconds
Fault Recognition Delay - Condensate Overflow	30 seconds	30 seconds
Thermostat Call Recognition Time	2 seconds	2 seconds
Auxiliary Heat Staging Delay	5 minutes	20 seconds
Emergency Heat Staging Delay	2 minutes	7.5 seconds
Water Valve Slow Open Delay	50 seconds	30 seconds
Reheat Delay	30 seconds	30 seconds

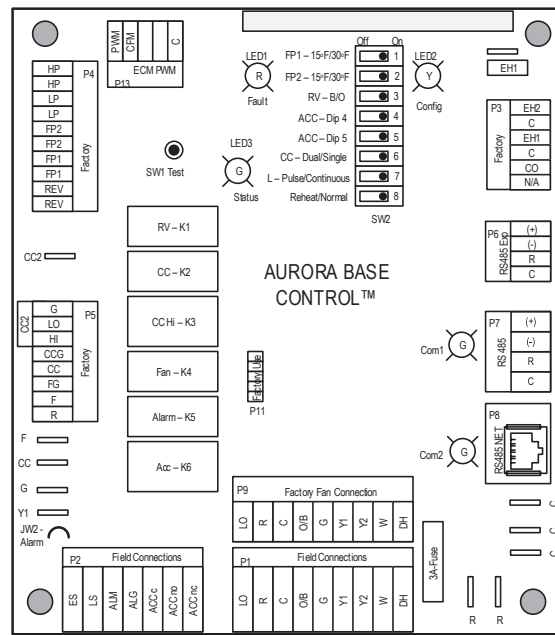

# Wiring Schematics

## Commercial Aurora Base with 5-Speed ECM and Hot Gas Reheat - 460/60/3

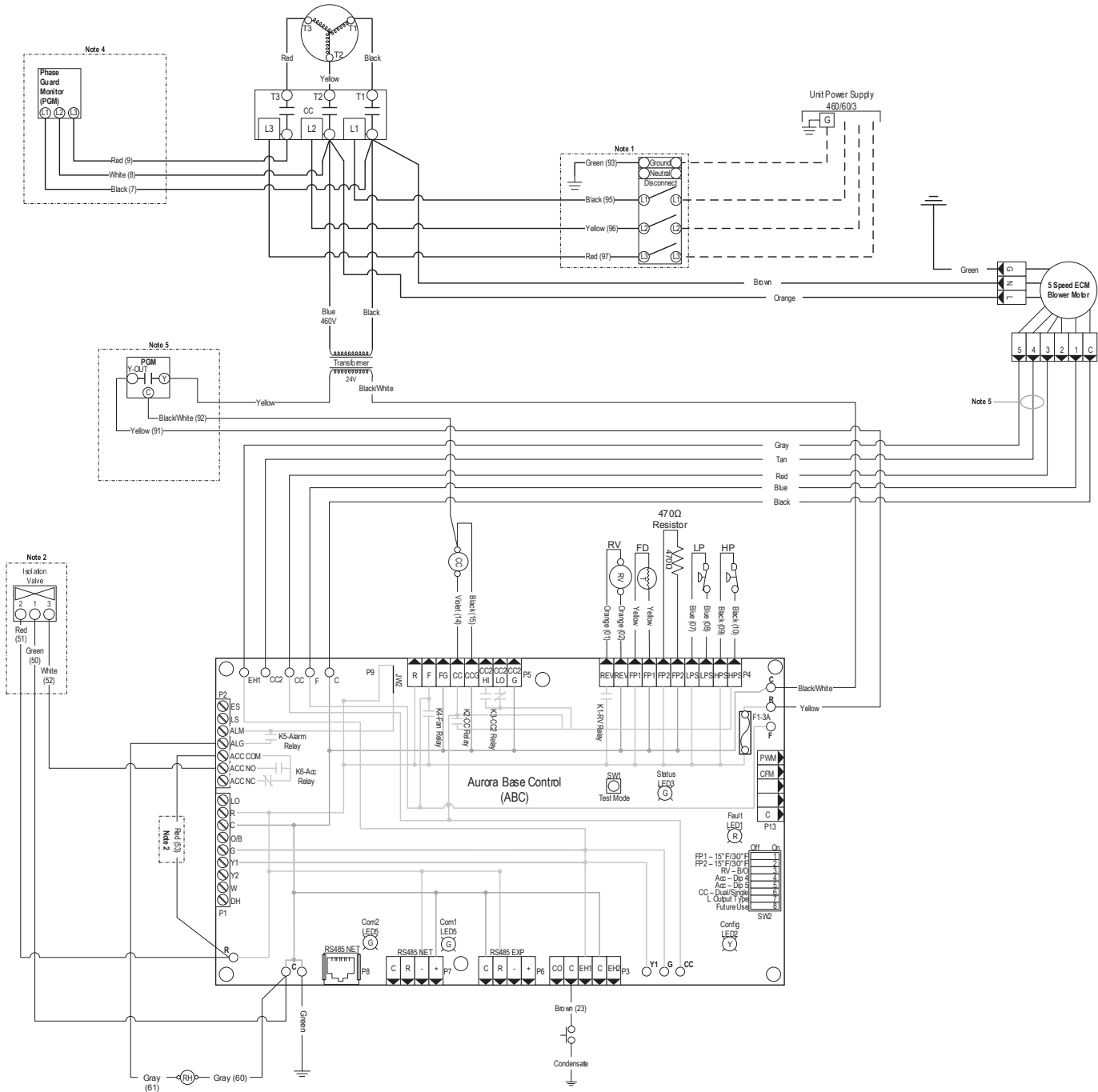

# Wiring Schematics cont.

## Commercial Aurora Base with 5-Speed ECM and Hot Gas Reheat - 460/60/3

97P819-08  
10/30/12

**Notes:**

- 1 - Optional, factory installed unit mounted disconnect.
- 2 - Optional, factory installed internal isolation valve.
- 3 - Optional, factory installed phase guard.
- 4 - Optional, factory installed phase guard. The yellow transformer wire shall be connected directly to the CPU board, if this option is not installed.
- 5 - Wire is provided with the unit but not connected to the 5-Speed ECM motor.

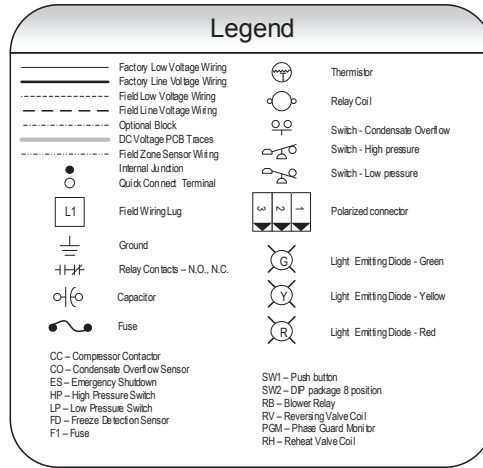

Aurora LED Flash Codes					
Slow Flash	1 second on and 1 second off				
Fast Flash	100 milliseconds on and 100 milliseconds off				
Flash Code	100 milliseconds on and 400 milliseconds off with a 2 second pause before repeating				
Random Start Delay					
Status LED (LED1, Green)	Fast Flash				
Configuration LED (LED2, Yellow)	Fast Flash				
Fault LED (LED3, Red)	Fast Flash				
Status LED (LED1, Green)	Configuration LED (LED2, Yellow)	Fault LED (LED3, Red)			
Normal Mode	ON	No Software Override	Flash ECM Setting	Normal Mode	OFF
Control is Non-Functional	OFF	DIP Switch Override	Slow Flash	Input Fault Lockout	Flash Code 1
Test Mode	Slow Flash	ECM Configure Mode	Fast Flash	High Pressure Lockout	Flash Code 2
Lockout Active	Fast Flash	Reset Configure Mode	Off	Low Pressure Lockout	Flash Code 3
Dehumidification Mode	Flash Code 2			Low Air Coil Limit Lockout - FP2	Flash Code 4
Reserved	Flash Code 3			Low Water Coil Limit Lockout - FP1	Flash Code 5
Reserved	Flash Code 4			Reserved	Flash Code 6
Load Shed	Flash Code 5			Condensate Overflow Lockout	Flash Code 7
ESD	Flash Code 6			Over/Under Voltage Shutdown	Flash Code 8
Reserved	Flash Code 7			Reserved	Flash Code 9
				Reserved	Flash Code 10
				Air/Water Coil Limit Sensor Error	Flash Code 11

Accessory Relay		
Operation	SW2-4	SW2-5
Cycle with Blower	On	On
Cycle with Compressor	Off	Off
Water Valve Slow Open	On	Off
Outdoor Air Damper	Off	On

Aurora Timing Events		
Event	Normal Mode	Test Mode
Random Start Delay	5 to 80 seconds	1 second
Compressor On Delay	5 seconds	< 1 second
Compressor Minimum On Time	2 minutes	5 seconds
Compressor Short Cycle Delay	4 minutes	15 seconds
Blower Off Delay	30 seconds	2 seconds
Fault Recognition Delay - High Pressure	Less than 1 second	Less than 1 second
Start-Up Bypass - Low Pressure	2 minutes	30 seconds
Fault Recognition Delay - Low Pressure	30 seconds	30 seconds
Start-Up Bypass - Low Water/Air Coil Limit	2 minutes	30 seconds
Fault Recognition Delay - Low Water/Air Coil Limit	30 seconds	30 seconds
Fault Recognition Delay - Condensate Overflow	30 seconds	30 seconds
Thermostat Call Recognition Time	2 seconds	2 seconds
Auxiliary Heat Staging Delay	5 minutes	20 seconds
Emergency Heat Staging Delay	2 minutes	7.5 seconds
Water Valve Slow Open Delay	90 seconds	90 seconds
Reheat Delay	30 seconds	30 seconds

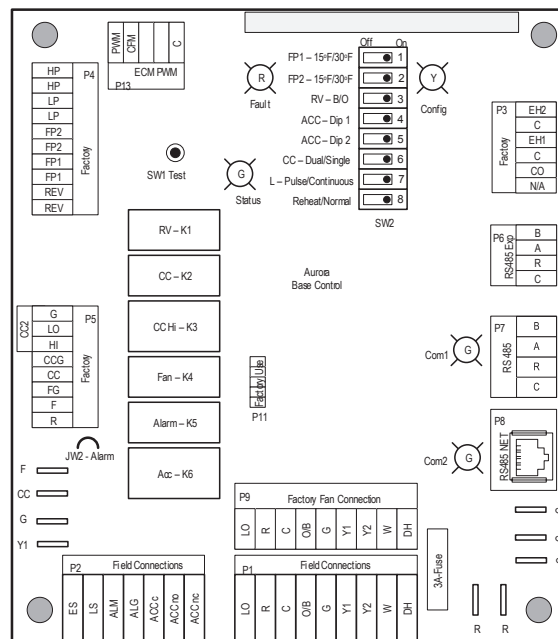

## Controls - Aurora Base Control

### Aurora 'Base' Control

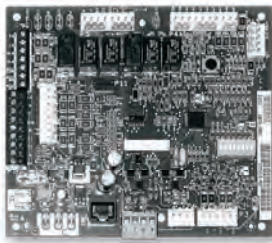

**NOTE:** Refer to the Aurora Base Control Application and Troubleshooting Guide and the Instruction Guide: Aurora Interface and Diagnostics (AID) Tool for additional information.

### Control Features

Software ABC Standard Version 2.0

#### Single or Dual Capacity Compressors

Either single or dual capacity compressors can be operated.

#### ECM Blower Motor Option

An ECM blower motor can be driven directly using the onboard PWM output. Four blower speeds are available based upon the G, Y1, Y2, and W input signals to the board. The blower speeds can be changed either by the ECM manual configurations mode method or by using the Aurora AID Tool directly. All four blower speeds can be set to the same speed if desired.

#### 5-Speed ECM Blower Motor Option

A 5-Speed ECM blower motor will be driven directly using the thermostat connections. Any of the G, Y1, or Y2/W signals can drive any of the 5 available pre-programmed blower speeds on the motor.

### Other Control Features

- Random start at power up
- Anti-short cycle protection
- High and low pressure cutouts
- Loss of charge
- Water coil freeze detection
- Air coil freeze detection
- Over/under voltage protection
- Condensate overflow sensor
- Load shed
- Dehumidification (where applicable)
- Emergency shutdown
- Hot gas reheat operation (where applicable)
- Diagnostic LED
- Test mode push button switch
- Two auxiliary electric heat outputs
- Alarm output
- Accessory output with N.O. and N.C.
- Modbus communication (master)
- Modbus communication (slave)

### Field Selectable Options via Hardware

**DIP Switch (SW1)** – Test/Configuration Button (See SW1 Operation Table)

#### Test Mode

The control is placed in the test mode by holding the push button switch SW1 for 2 - 5 seconds. In test mode most of the control timings will be shortened by a factor of sixteen (16). LED3 (green) will flash at 1 second on and 1 second off. Additionally, when entering test mode LED1 (red) will flash the last lockout one time. Test mode will automatically time out after 30 minutes. Test mode can be exited by pressing and holding the SW1 button for 2 to 5 seconds or by cycling the power. **NOTE:** Test mode will automatically be exited after 30 minutes.

#### ECM Configuration Mode

The control is placed in the ECM configuration mode by holding the pushbutton switch SW1 for 5 to 10 seconds, the high, low, and "G" ECM speeds can be selected by following the LED display lights. LED2 (yellow) will fast flash when entering the ECM configuration. When setting "G" speed LED3 (green) will be continuously lit, for low speed LED1 (red) will be continuously lit, and for high speed both LED3 (green) and LED1 (red) will be continuously lit. During the ECM configuration mode LED2 (yellow) will flash each of the 12 possible blower speeds 3 times. When the desired speed is flashed press SW1, LED2 will fast flash until SW1 is released. "G" speed has now been selected. Next select low speed, and high speed blower selections following the same process above. After third selection has been made, the control will exit the ECM configuration mode. Aux fan speed will remain at default or current setting and requires the AID Tool for adjustment.

#### Reset Configuration Mode

The control is placed in reset configuration mode by holding the push button switch SW1 for 50 to 60 seconds. This will reset all configuration settings and the EEPROM back to the factory default settings. LED3 (green) will turn off when entering reset configuration mode. Once LED3 (green) turns off, release SW1 and the control will reset.

#### DIP Switch (SW2)

- SW2-1** FP1 Selection – Low water coil temperature limit setting for freeze detection. On = 30°F; Off = 15°F.
- SW2-2** FP2 Selection – On = 30°F; Off = N/A
- SW2-3** RV – O/B - thermostat type. Heat pump thermostats with "O" output in cooling or "B" output in Heating can be selected. On = O; Off = B.
- SW2-4** Access Relay Operation (P2) and 2-5

Access Relay Operation	SW2-4	SW2-5
Cycle with Blower	ON	ON
Cycle with Compressor	OFF	OFF
Water Valve Slow Opening	ON	OFF
Cycle with Comm. T-stat Hum Cmd	OFF	ON

## Controls - Aurora Base Control cont.

**Cycle with Blower** - The accessory relay will cycle with the blower output.

**Cycle with Compressor** - The accessory relay will cycle with the compressor output.

**Water Valve Slow Opening** - The accessory relay will cycle and delay both the blower and compressor output for 90 seconds.

- SW2-6** CC Operation – selection of single or dual capacity compressor. On = Single Stage; Off = Dual Capacity
- SW2-7** Lockout and Alarm Outputs (P2) – selection of a continuous or pulsed output for both the LO and ALM Outputs. On = Continuous; Off = Pulsed
- SW2-8** Future Use

### Alarm Jumper Clip Selection

From the factory, ALM is connected to 24 VAC via JW2. By cutting JW2, ALM becomes a dry contact connected to ALG.

### ECM Blower Speeds

The blower speeds can be changed either by using the ECM manual configurations mode method or by using the Aurora AID Tool directly (see Instruction Guide: Aurora Interface and Diagnostics (AID) Tool topic).

## Field Selectable Options via Software

(Selectable via the Aurora AID Tool)

### ECM Blower Speeds

An ECM blower motor can be driven directly using the onboard PWM output. Four blower speeds are available, based upon the “G”, Y1 (low), Y2 (high), and Aux input signals to the board. The blower speeds can be changed either by the ECM manual configurations mode method (see ECM Configuration Mode topic) or by using the Aurora AID Tool directly. All four blower speeds can be set to the same speed if desired. Aux blower speed will remain at default or current setting and requires the AID Tool for adjustment.

## Safety Features

The following safety features are provided to protect the compressor, heat exchangers, wiring and other components from damage caused by operation outside of design conditions.

**Fuse** – a 3 amp automotive type plug-in fuse provides protection against short circuit or overload conditions.

**Anti-Short Cycle Protection** – 4 minute anti-short cycle protection for the compressor.

**Random Start** – 5 to 80 second random start upon power up.

**Fault Retry** – in the fault condition, the control will stage off the outputs and then “try again” to satisfy the thermostat Y input call. Once the thermostat input calls are satisfied, the control will continue on as if no fault occurred. If 3 consecutive faults occur without satisfying the thermostat Y input call, then the control will go to Lockout mode.

**Lockout** – when locked out, the blower will operate continuously in “G” speed, and PSC blower motor output will remain on. The Alarm output (ALM) and Lockout output (L) will be turned on. The fault type identification display LED1 (Red) shall flash the fault code. To reset lockout conditions with SW2-8 On, thermostat inputs “Y1”, “Y2”, and “W” must be removed for at least 3 seconds. To reset lockout conditions with SW2-8 Off, thermostat inputs “Y1”, “Y2”, “W”, and “DH” must be removed for at least 3 seconds. Lockout may also be reset by turning power off for at least 30 seconds or by enabling the emergency shutdown input for at least 3 seconds.

**Lockout With Emergency Heat** - if the control is locked out in the heating mode, and a Y2 or W input is received, the control will operate in the emergency heat mode while the compressor is locked out. The first emergency heat output will be energized 10 seconds after the W input is received, and the blower will shift to high speed. If the control remains locked out, and the W input is present, additional stage of emergency heat will stage on after 2 minutes. When the W input is removed, all of the emergency heat outputs will turn off, and the ECM blower will shift to “G” speed and PSC blower motor output will remain on.

**High Pressure** – fault is recognized when the Normally Closed High Pressure Switch, P4-9/10 opens, no matter how momentarily. The High Pressure Switch is electrically in series with the Compressor Contactor and serves as a hard-wired limit switch if an overpressure condition should occur.

**Low Pressure** - fault is recognized when the Normally Closed Low Pressure Switch, P4-7/8 is continuously open for 30 seconds. Closure of the LPS any time during the 30 second recognition time restarts the 30 second continuous open requirement. A continuously open LPS shall not be recognized during the 2 minute startup bypass time.

**Loss of Charge** – fault is recognized when the Normally Closed Low Pressure Switch, P4-7/8 is open prior to the compressor starting.

**Condensate Overflow** - fault is recognized when the impedance between this line and 24 VAC common or chassis ground drops below 100K ohms for 30 seconds continuously.

**Freeze Detection (Coax)** - set points shall be either 30°F or 15°F. When the thermistor temperature drops below the selected set point, the control shall begin counting down the 30 seconds delay. If the thermistor value rises above the selected set point, then the count should reset. The resistance value must remain below the selected set point for the entire length of the appropriate delay to be recognized as a fault. This fault will be ignored for the initial 2 minutes of the compressor run time.

**Freeze Detection (Air Coil)** - uses the FP2 input to protect against ice formation on the air coil. The FP2 input will operate exactly like FP1 except that the set point is 30 degrees and is not field adjustable.

## Controls - Aurora Base Control cont.

**Over/Under Voltage Shutdown** - An over/under voltage condition exists when the control voltage is outside the range of 18 VAC to 30 VAC. If the over/under voltage shutdown lasts for 15 minutes, the lockout and alarm relay will be energized. Over/under voltage shutdown is self-resetting in that if the voltage comes back within range of 18 VAC to 30 VAC for at least 0.5 seconds, then normal operation is restored.

### Operation Description

**Power Up** - The unit will not operate until all the inputs and safety controls are checked for normal conditions. The unit has a 5 to 80 second random start delay at power up. Then the compressor has a 4 minute anti-short cycle delay after the random start delay.

Standby In standby mode, Y1, Y2, W, DH, and G are not active. Input O may be active. The blower and compressor will be off.

### Heating Operation

**Heating, 1st Stage (Y1)** - The blower is started on "G" speed immediately and the compressor is energized 10 seconds after the Y1 input is received. The ECM blower motor is switched to low speed 15 seconds after the Y1 input.

**Heating, 2nd Stage (Y1, Y2)** - The compressor will be staged to full capacity 20 seconds after Y2 input is received. The ECM blower will shift to high speed 15 seconds after the Y2 input is received.

**Heating, 3rd Stage (Y1, Y2, W)** - The hot water pump is de-energized and the first stage of electric heat is energized 10 seconds after the W command is received. If the demand continues the second stage of electric heat will be energized after 5 minutes.

**Emergency Heat (W)** - The blower will be started on "G" speed, 10 seconds later the first stage of electric heat will be turned on. 5 seconds after the first stage of electric heat is energized the blower will shift to Aux speed. If the emergency heat demand is not satisfied after 2 minutes the second electric heat stage will be energized.

**Blower (G)** - The blower will start immediately upon receiving a thermostat G command. If there are no other commands from the thermostat the ECM will run on "G" speed until the G command is removed. Regardless of blower input (G) from the thermostat, the blower will remain on for 30 seconds at the end of each heating cycle.

### Cooling Operation

In all cooling operations, the reversing valve directly tracks the O input. Thus, anytime the O input is present, the reversing valve will be energized.

**Cooling, 1st Stage (Y1, O)** - The blower is started on "G" speed immediately and the compressor is energized 10 seconds after the Y1 input is received. The ECM blower motor is switched to low speed 15 seconds after the Y1 input.

**Cooling, 2nd Stage (Y1, Y2, O)** - The compressor will be staged to full capacity 20 seconds after Y2 input is received. The ECM blower will shift to high speed 15 seconds after the Y2 input is received.

**Blower (G)** - The blower will start immediately upon receiving a thermostat G command. If there are no other commands from the thermostat the ECM will run on "G" speed until the G command is removed. Regardless of blower input (G) from the thermostat, the blower will remain on for 30 seconds at the end of each heating, cooling, and emergency heat cycle.

**Dehumidification (Y1, O, DH or Y1, Y2, O, DH)** - When a DH command is received from the thermostat during a compressor call for cooling the ECM blower speed will be reduced by 15% to increase dehumidification.

**Emergency Shutdown** - Four (4) seconds after a valid ES input, P2-7 is present, all control outputs will be turned off and remain off until the emergency shutdown input is no longer present. The first time that the compressor is started after the control exits the emergency shutdown mode, there will be an anti-short cycle delay followed by a random start delay. Input must be tied to common to activate.

**Continuous Blower Operation** - The blower output will be energized any time the control has a G input present, unless the control has an emergency shutdown input present. The blower output will be turned off when G input is removed.

**Load Shed** - The LS input disables all outputs with the exception of the blower output. When the LS input has been cleared, the anti-short cycle timer and random start timer will be initiated. Input must be tied to common to activate.



## Controls - Aurora Base Control cont.

### Aurora 'Base' Control LED Displays

These three LEDs display the status, configuration, and fault codes for the control. These can also be read in plain English via the Aurora AID Tool.

#### Status LED (LED3, Green)

Description of Operation	Fault LED, Green
Normal Mode	ON
Control is Non-functional	OFF
Test Mode	Slow Flash
Lockout Active	Fast Flash
Dehumidification Mode	Flash Code 2
(Future Use)	Flash Code 3
(Future Use)	Flash Code 4
Load Shed	Flash Code 5
ESD	Flash Code 6
(Future Use)	Flash Code 7

#### Configuration LED (LED2, Yellow)

Description of Operation	Configuration LED, Yellow
No Software Overwritten	Flashing ECM Setting
DIP Switch was Overwritten	Slow Flash
ECM Configuration Mode	Fast Flash

#### Fault LED (LED1, Red)

Red Fault LED		LED Flash Code*	Lockout	Reset/Remove
ABC Basic Faults	Normal - No Faults	OFF	-	
	Fault - Input	1	No	Auto
	Fault - High Pressure	2	Yes	Hard or Soft
	Fault - Low Pressure	3	Yes	Hard or Soft
	Fault - Freeze Detection FP2	4	Yes	Hard or Soft
	Fault - Freeze Detection FP1	5	Yes	Hard or Soft
	Fault - Condensate Overflow	7	Yes	Hard or Soft
	Fault - Over/Under Voltage	8	No	Auto
	Fault - FP1 & FP2 Sensor Error	11	Yes	Hard or Soft

**NOTE:** All codes >11 use long flash for tens digit and short flash for the ones digit. 20, 30, 40, 50, etc. are skipped.

### Aurora Interface and Diagnostics (AID) Tool

The Aurora Interface and Diagnostics (AID) Tool is a device that is a member of the Aurora network. The AID Tool is used to troubleshoot equipment which uses the Aurora control via Modbus RTU communication. The AID Tool provides diagnostics, fault management, ECM setup, and system configuration capabilities to the Aurora family of controls. An AID Tool is recommended, although not required, for ECM airflow settings. The AID Tool simply plugs into the exterior of the cabinet in the AID Tool port.



### ABC Control Board Layout

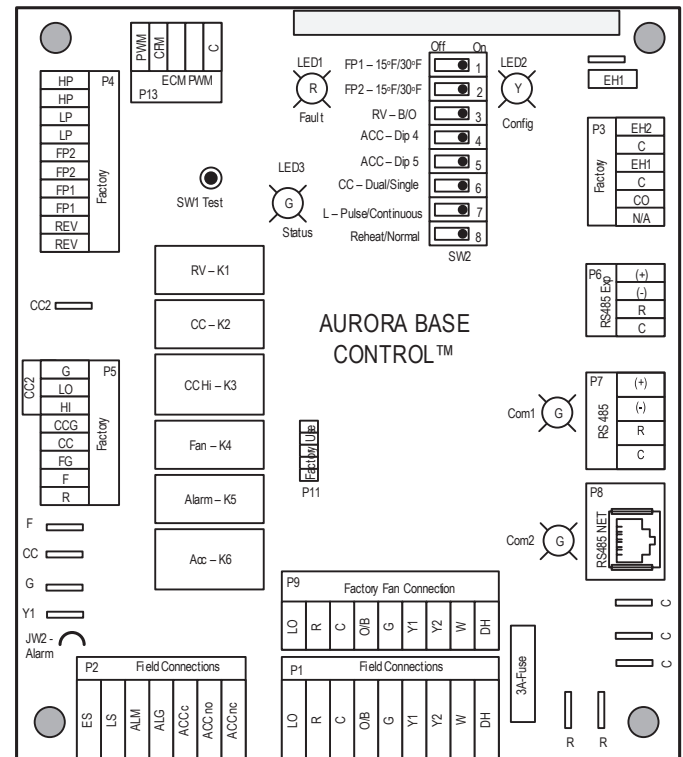

## Unit Startup

### Before Powering Unit, Check The Following:

**NOTE:** Remove and discard the compressor shipping bolts. The bolts can then be discarded.

- High voltage is correct and matches nameplate.
- Fuses, breakers and wire size correct.
- Low voltage wiring complete.
- Piping completed and water system cleaned and flushed.
- Air is purged from closed loop system.
- Isolation valves are open, water control valves or loop pumps wired.
- Condensate line open and correctly pitched.
- Transformer switched to 208V if applicable.
- Dip switches are set correctly.
- Blower rotates freely – foam shipping support has been removed.
- Blower speed correct.
- Air filter/cleaner is clean and in position.
- Service/access panels are in place.
- Return air temperature is between 50-80°F heating and 60-95°F cooling.
- Check air coil cleanliness to insure optimum performance. Clean as needed according to maintenance guidelines. To obtain maximum performance the air coil should be cleaned before startup. A 10-percent solution of dishwasher detergent and water is recommended for both sides of coil, a thorough water rinse should follow.

### Startup Steps

**NOTE:** Complete the Equipment Start-Up/Commissioning Check Sheet during this procedure. Refer to thermostat operating instructions and complete the startup procedure.

1. Initiate a control signal to energize the blower motor. Check blower operation.
2. Initiate a control signal to place the unit in the cooling mode. Cooling setpoint must be set below room temperature.
3. Cooling will energize after a time delay. Check for correct rotation of scroll compressors in 3 phase applications. Incorrect rotation will cause low refrigerant pressures and possibly unusual noise. Switch any two power leads at the compressor or contactor to reverse rotation.
4. Be sure that the compressor and water control valve or loop pump(s) are activated.
5. Verify that the water flow rate is correct by measuring the pressure drop through the heat exchanger using the P/T plugs and comparing to the pressure drop table.
6. Check the temperature of both the supply and discharge water (Refer to Unit Operating Parameters tables).
7. Check for an air temperature drop of 15°F to 25°F across the air coil, depending on the blower speed and entering water temperature.
8. Decrease the cooling set point several degrees and verify high-speed blower operation (ECM only).
9. Adjust the cooling setpoint above the room temperature and verify that the compressor and water valve or loop pumps deactivate.
10. Initiate a control signal to place the unit in the heating mode. Heating set point must be set above room temperature.
11. Heating will energize after a time delay.
12. Check the temperature of both the supply and discharge water (Refer to Unit Operating Parameters tables).
13. Check for an air temperature rise of 20°F to 35°F across the air coil, depending on the blower speed and entering water temperature.
14. If auxiliary electric heaters are installed, increase the heating setpoint until the electric heat banks are sequenced on. All stages of the auxiliary heater should be sequenced on when the thermostat is in the Emergency Heat mode. Check amperage of each element.
15. Adjust the heating setpoint below room temperature and verify that the compressor and water valve or loop pumps deactivate.
16. During all testing, check for excessive vibration, noise or water leaks. Correct or repair as required.
17. Set system to desired normal operating mode and set temperature to maintain desired comfort level.
18. Instruct the owner/operator in the proper operation of the thermostat and system maintenance.

**NOTE:** Be certain to fill out and forward all warranty registration papers.



## Operating Limits

Operating Limits	Cooling		Heating	
	(°F)	(°C)	(°F)	(°C)
<b>Air Limits</b>				
Min. Ambient Air	45	7.2	45	7.2
Rated Ambient Air	80	26.7	70	21.1
Max. Ambient Air	100	37.8	85	29.4
Min. Entering Air	50	10.0	40	4.4
Rated Entering Air db/wb	80.6/66.2	27/19	68	20.0
Max. Entering Air db/wb	110/83	43/28.3	80	26.7
<b>Water Limits</b>				
Min. Entering Water	30	-1.1	20	-6.7
Normal Entering Water	50-110	10-43.3	30-70	-1.1
Max. Entering Water	120	48.9	90	32.2

**NOTE:** Minimum/maximum limits are only for start-up conditions, and are meant for bringing the space up to occupancy temperature. Units are not designed to operate at the minimum/maximum conditions on a regular basis. The operating limits are dependant upon three primary factors: 1) water temperature, 2) return air temperature, and 3) ambient temperature. When any of the factors are at the minimum or maximum levels, the other two factors must be at the normal level for proper and reliable unit operation.

## Operating Parameters

Entering Water Temp °F	Water Flow GPM/Ton	Cooling -- No Hot Water Generation					
		Suction Pressure PSIG	Discharge Pressure PSIG	Superheat	Subcooling	Water Temp Rise °F	Air Temp Drop °F DB
30	1.5	100-115	170-190	17 - 26	10 - 14	18 - 22	18 - 22
	3.0	95-110	150-170	20 - 29	7 - 11	8 - 10	18 - 22
50	1.5	133 - 148	205 - 225	17 - 26	10 - 14	18 - 22	18 - 22
	3.0	129 - 144	185 - 205	20 - 29	7 - 11	8 - 10	18 - 22
70	1.5	139 - 154	280 - 300	8 - 11	8 -12	18 - 22	18 - 22
	3.0	137 - 152	250 - 270	9 - 12	7 - 11	8 - 10	18 - 22
90	1.5	143 - 158	360 - 380	8 - 11	9 - 13	18 - 22	16 - 20
	3.0	141 - 156	330 - 350	9 - 12	8 - 12	8 - 10	16 - 20
110	2.3	143 - 158	360 - 380	8 - 11	9 - 13	18 - 22	16 - 20
	3.0	141 - 156	440-460	9 - 12	8 - 12	8 - 10	16 - 20

Entering Water Temp °F	Water Flow GPM/Ton	Heating -- No Hot Water Generation					
		Suction Pressure PSIG	Discharge Pressure PSIG	Superheat	Subcooling	Water Temp Drop °F	Air Temp Rise °F DB
30	1.5	73 - 79	279 - 304	7 - 13	2 - 6	7 -10	18 - 24
	3.0	79 - 85	285 - 310	8 - 14	2 - 6	3 - 6	20 - 26
50	1.5	103 - 109	308 - 333	8 - 12	4 - 8	8 - 11	20 - 26
	3.0	110 - 116	315 - 340	9 - 13	4 - 8	4 - 7	22 - 28
70	1.5	140 - 146	330 - 365	10 - 14	7 - 11	11 - 14	26 - 32
	3.0	146 - 153	340 - 375	10 - 14	7 - 11	7 - 10	28 - 34
90	1.5	170-177	425-460	14-18	12-16	8-11	42-50
	3.0	174-181	435-470	14-18	12-16	8-11	42-50
110	2.3						
	3.0						

**NOTES:** Cooling performance based on entering air temperatures of 80°F DB, 67°F WB.  
Heating performance based on entering air temperature of 70°F DB.

# Pressure Drop

Model	gpm	Pressure Drop (psi)				
		30°F	50°F	70°F	90°F	110°F
009	1.5	2.0	1.7	1.4	1.3	1.0
	2.0	3.8	3.2	2.8	2.3	1.8
	3.0	7.2	6.0	5.1	4.5	4.0
	4.0	12.0	10.0	9.0	7.5	6.0
012	1.5	1.1	1.0	0.9	0.8	0.7
	2.5	2.5	2.3	2.1	1.8	1.5
	3.5	3.9	3.6	3.2	2.7	2.3
	4.5	5.3	4.9	4.5	3.8	3.5
015	2.0	0.6	0.5	0.5	0.4	0.4
	3.0	1.1	1.0	0.9	0.8	0.6
	4.0	1.9	1.8	1.6	1.5	1.3
	5.0	3.3	3.2	3.0	2.9	2.7
018	3.0	1.1	1.0	0.9	0.8	0.6
	4.0	1.9	1.8	1.6	1.5	1.3
	5.0	3.3	3.2	3.0	2.9	2.7
	6.0	4.5	4.4	4.3	4.1	4.0
023	3.0	1.1	1.0	0.9	0.8	0.6
	4.5	2.4	2.2	2.1	2.0	1.9
	6.0	4.5	4.4	4.3	4.1	4.0
	8.0	6.7	6.6	6.5	6.3	6.2
024	3.0	1.1	1.0	0.9	0.8	0.6
	4.5	2.4	2.2	2.1	2.0	1.9
	6.0	4.5	4.4	4.3	4.1	4.0
	8.0	6.7	6.6	6.5	6.3	6.2
030	4.0	0.9	0.8	0.7	0.6	0.5
	6.0	1.9	1.8	1.7	1.6	1.5
	8.0	3.7	3.6	3.5	3.4	3.3
	10.0	4.8	4.7	4.6	4.5	4.4
036	5.0	1.4	1.1	0.9	0.7	0.5
	7.0	2.5	2.3	2.1	1.8	1.6
	9.0	6.0	5.8	5.5	5.3	5.1
	12.0	6.6	6.4	6.2	6.0	5.7
041	5.0	1.5	1.2	0.9	0.5	0.4
	8.0	3.4	3.1	2.8	2.5	2.1
	11.0	7.9	7.5	7.2	6.9	6.6
	14.0	9.1	8.8	8.5	8.2	7.9
042	5.0	1.5	1.2	0.9	0.5	0.4
	8.0	3.4	3.1	2.8	2.5	2.1
	11.0	7.9	7.5	7.2	6.9	6.6
	14.0	9.1	8.8	8.5	8.2	7.9
048	6.0	2.0	1.7	1.3	1.0	0.6
	9.0	4.2	3.8	3.5	3.1	2.7
	12.0	6.7	6.3	5.9	5.6	5.2
	16.0	11.5	11.2	10.8	10.5	10.1
060	9.0	3.6	3.3	3.0	2.7	2.3
	12.0	6.1	5.8	5.5	5.2	4.8
	15.0	9.6	9.2	8.9	8.6	8.3
	20.0	15.5	15.2	14.9	14.5	14.2
070	12.0	4.1	3.6	3.2	2.8	2.3
	15.0	5.9	5.0	4.6	4.1	3.7
	18.0	8.8	8.4	7.9	7.5	7.1
	24.0	12.9	12.0	11.5	11.1	10.7

7/6/10

Valve	gpm	Cv	Pressure Drop (psi)
1/2 in.	1.5	9.6	0.02
	2.0	9.7	0.04
	3.0	9.9	0.09
	4.0	10.1	0.16
1/2 in.	1.5	9.6	0.02
	2.5	9.8	0.06
	3.5	10.0	0.12
	4.5	10.2	0.19
1/2 in.	2.0	9.7	0.04
	3.0	9.9	0.09
	4.0	10.1	0.16
	5.0	10.4	0.23
1/2 in.	3.0	9.9	0.09
	4.0	10.1	0.16
	5.0	10.4	0.23
	6.0	10.6	0.32
3/4 in.	3.0	9.9	0.09
	4.5	10.2	0.19
	6.0	10.6	0.32
	8.0	11.0	0.53
3/4 in.	3.0	9.9	0.09
	4.5	10.2	0.19
	6.0	10.6	0.32
	8.0	11.0	0.53
3/4 in.	4.0	10.1	0.16
	6.0	10.6	0.32
	8.0	11.0	0.53
	10.0	11.5	0.76
3/4 in.	5.0	10.4	0.23
	7.0	10.8	0.42
	9.0	11.2	0.64
	12.0	11.9	1.02
3/4 in.	5.0	10.4	0.23
	8.0	11.0	0.53
	11.0	11.7	0.89
	14.0	12.3	1.29
1 in.	5.0	15.9	0.10
	8.0	16.6	0.23
	11.0	17.2	0.41
	14.0	17.9	0.61
1 in.	6.0	16.1	0.14
	9.0	16.8	0.29
	12.0	17.4	0.47
	16.0	18.3	0.76
1 in.	9.0	16.8	0.29
	12.0	17.4	0.47
	15.0	18.1	0.69
	20.0	19.2	1.09
1 in.	12.0	17.4	0.47
	15.0	18.1	0.69
	18.0	18.7	0.92
	24.0	20.1	1.43

11/10/09

## Reference Calculations

Heating Calculations:	Cooling Calculations:
$LWT = EWT - \frac{HE}{GPM \times 500}$	$LWT = EWT + \frac{HR}{GPM \times 500}$
$LAT = EAT + \frac{HC}{CFM \times 1.08}$	$LAT (DB) = EAT (DB) - \frac{SC}{CFM \times 1.08}$
$TH = HC + HWC$	$LC = TC - SC$
	$S/T = \frac{SC}{TC}$

## Legend

### ABBREVIATIONS AND DEFINITIONS:

CFM = airflow, cubic feet/minute	HE = total heat of extraction, MBTUH
EWT = entering water temperature, Fahrenheit	HWC = hot water generator capacity, MBTUH
GPM = water flow in gallons/minute	EER = Energy Efficient Ratio
WPD = water pressure drop, PSI and feet of water	= BTU output/Watt input
EAT = entering air temperature, Fahrenheit	COP = Coefficient of Performance
(dry bulb/wet bulb)	= BTU output/BTU input
HC = air heating capacity, MBTUH	LWT = leaving water temperature, °F
TC = total cooling capacity, MBTUH	LAT = leaving air temperature, °F
SC = sensible cooling capacity, MBTUH	TH = total heating capacity, MBTUH
KW = total power unit input, kilowatts	LC = latent cooling capacity, MBTUH
HR = total heat of rejection, MBTUH	S/T = sensible to total cooling ratio

## Refrigerant Circuit Guideline

Symptom	Head Pressure	Suction Pressure	Compressor Amp Draw	Superheat	Subcooling	Air Temp. Differential	Water Temp. Differential
Under Charged System (Possible Leak)	Low	Low	Low	High	Low	Low	Low
Over Charged System	High	High	High	Normal	High	Normal/Low	Normal
Low Air Flow Heating	High	High	High	High/Normal	Low	High	Low
Low Air Flow Cooling	Low	Low	Low	Low/Normal	High	High	Low
Low Water Flow Heating	Low/Normal	Low/Normal	Low	Low	High	Low	High
Low Water Flow Cooling	High	High	High	High	Low	Low	High
High Air Flow Heating	Low	Low	Low	Low	High	Low	Low
High Air Flow Cooling	Low	High	Normal	High	Low	Low	Normal
High Water Flow Heating	Normal	Low	Normal	High	Normal	Normal	Low
High Water Flow Cooling	Low	Low	Low	Low	High	Normal	Low
Low Indoor Air Temperature Heating	Low	Low	Low	Normal	High	Normal	Normal/High
Low Indoor Air Temperature Cooling	Low	Low	Low	Normal/Low	High	Low	Low
High Indoor Air Temperature Heating	High	High	High	Normal/High	Normal/Low	Low	Normal
High Indoor Air Temperature Cooling	High	High	High	High	Low	Low	High
Restricted TXV (Check Service Advisory)	High	Low	Normal/Low	High	High	Low	Low
Insufficient Compressor (Possible Bad Valves)	Low	High	Low	High	Normal/High	Low	Low
TXV - Bulb Loss of Charge	Low	Low	Low	High	High	Low	Low
Scaled Coaxial Heat Exchanger Heating	Low	Low	Low	Normal/Low	High	Low	Low
Scaled Coaxial Heat Exchanger Cooling	High	High	High	Normal/Low	Low	Low	Low
Restricted Filter Drier	Check temperature difference (delta T) across filter drier.						

## Compressor and Thermistor Resistance

### Compressor Resistance Chart

Model	208-230/60/1		265/60/1		208-230/60/3	460/60/3	575/60/4
	Run	Start	Run	Start			
009	3.65 - 4.19	3.75 - 4.31	3.73 - 4.27	4.45 - 5.13	n/a	n/a	n/a
012	3.35 - 3.85	2.80 - 3.22	3.73 - 4.27	4.45 - 5.13	n/a	n/a	n/a
015	2.74 - 3.16	2.60 - 3.00	3.03 - 3.49	2.39 - 2.75	n/a	n/a	n/a
018	2.24 - 2.58	2.84 - 3.26	3.03 - 3.49	2.39 - 2.75	n/a	n/a	n/a
023-024	1.14 - 1.32	1.37 - 1.57	1.38 - 1.58	2.02 - 2.32	1.45 - 1.67	8.04 - 9.24	n/a
030	0.95 - 1.09	1.81 - 2.09	1.24 - 1.42	2.42 - 2.78	1.77 - 2.04	7.57 - 8.71	n/a
036	0.62 - 0.72	1.46 - 1.65	1.13 - 1.31	1.07 - 1.23	0.83 - 0.91	4.43 - 4.90	n/a
041-042	0.49 - 1.03	1.29 - 1.49	n/a		0.81 - 1.05	4.33 - 4.99	5.11 - 5.64
048	0.51 - 0.58	1.36 - 1.57	n/a		0.91 - 1.05	3.60 - 4.14	4.16 - 4.78
060	0.29 - 0.34	0.76 - 0.87	n/a		0.56 - 0.64	2.17 - 2.49	3.78 - 4.34
070	0.26 - 0.29	0.76 - 0.87	n/a		0.56 - 0.64	2.17 - 2.49	3.78 - 4.35

7/6/10

### Thermistor Resistance Chart

Thermistor Temperature (°F)	Microprocessor Resistance (Ohms)	FX10 Resistance (Ohms)
5	75757-70117	746-770
14	57392-53234	775-803
23	43865-40771	808-836
32	33809-31487	841-869
41	26269-24513	875-903
50	20570-19230	910-938
59	16226-15196	946-974
68	12889-12093	981-1013
77	10310-9688	1019-1051
86	8300-7812	1058-1090
95	6723-6337	1097-1129
104	5480-5172	1137-1169
113	4490-4246	1179-1211
122	3700-3504	1221-1253
131	3067-2907	1261-1297
140	2554-2424	1305-1341
149	2149-2019	1350-1386

7/6/10

## Heat of Extraction/Rejection Data

Model	GPM	Heat Of Extraction (HE)				Heat of Rejection (HR)				
		30°F	50°F	70°F	90°F	30°F	50°F	70°F	90°F	110°F
009	1.5		5.2	7.1	9.9		13.1	12.2	11.3	
	2.0	3.9	5.4	7.4	10.1	13.0	13.1	12.2	11.3	10.6
	3.0	4.6	5.8	7.9	10.3	13.0	13.0	12.3	11.3	10.6
012	1.5		7.4	9.6	12.5		16.9	16.5	15.8	
	2.5	5.9	7.7	10.1	12.7	17.3	16.9	16.4	15.9	16.0
	3.5	6.1	8.1	10.6	12.9	17.4	16.9	16.4	16.0	16.1
015	2.0		9.4	12.0	15.6		19.4	18.2	17.1	
	3.0	7.4	9.7	12.5	15.9	16.9	19.6	18.4	17.2	16.7
	4.0	7.6	10.0	13.0	16.1	17.0	19.8	18.5	17.3	16.8
018	3.0		11.4	13.9	19.1		23.0	21.6	20.5	
	4.0	10.1	12.2	14.8	19.5	21.1	23.3	21.7	20.5	20.1
	5.0	10.4	13.1	15.8	19.8	21.2	23.6	21.9	20.7	20.1
023	3.0		14.7	18.8	24.1		31.1	30.7	29.6	
	4.5	11.9	15.4	19.6	24.5	30.1	31.1	30.6	29.6	29.2
	6.0	12.2	16.0	20.4	24.9	30.2	31.1	30.6	29.8	29.3
024	3.0		15.6	19.8	25.4		32.2	31.8	30.5	
	4.5	12.7	16.3	20.6	25.8	31.2	32.2	31.7	30.6	29.5
	6.0	13.0	16.9	21.5	26.2	31.4	32.2	31.6	30.8	29.7
030	4.0		18.9	25.9	32.9		35.2	35.4	37.0	
	6.0	14.5	19.9	27.0	33.4	35.1	37.2	37.6	37.6	34.7
	8.0	15.2	20.9	28.0	34.0	35.2	39.1	39.7	37.9	35.0
036	5.0		24.6	33.0	41.7		47.4	45.3	44.1	
	7.0	19.0	25.7	34.3	42.4	41.5	47.7	45.8	44.2	42.4
	9.0	19.6	26.8	35.5	43.1	41.7	48.1	46.3	44.6	42.7
041	5.0		23.7	31.6	41.0		53.1	52.7	51.6	
	8.0	18.9	25.1	32.9	41.7	48.4	53.3	53.5	51.7	48.5
	11.0	19.7	26.5	34.3	42.4	48.6	53.6	54.2	52.2	48.9
042	5.0		25.5	33.8	43.8		55.0	54.5	53.4	
	8.0	20.4	27.0	35.2	44.5	50.2	55.3	55.3	53.5	50.0
	11.0	21.2	28.4	36.7	45.2	50.4	55.5	56.1	54.0	50.4
048	6.0		31.0	43.0	52.9		64.6	65.8	62.5	
	9.0	24.0	33.3	45.7	53.7	58.3	65.2	65.9	62.7	59.9
	12.0	24.4	35.6	48.4	54.6	58.5	65.8	66.0	63.2	60.4
060	9.0		40.3	54.4	66.8		79.9	79.4	75.0	
	12.0	30.2	41.7	56.9	67.8	82.1	80.6	79.9	75.2	71.6
	15.0	32.5	43.1	59.3	68.9	82.5	81.3	80.4	75.9	72.1
070	12.0		44.9	61.7	78.0		87.0	84.0	80.4	
	15.0	35.2	47.4	63.1	79.2	84.3	88.7	85.2	80.4	78.0
	18.0	36.4	49.8	64.5	80.5	84.6	90.5	86.4	81.1	78.5

7/6/10

## Troubleshooting

Should a major problem develop, refer to the following information for possible causes and corrective steps.

### If compressor won't run:

1. The fuse may be open or the circuit breaker is tripped. Check electrical circuits and motor windings for shorts or grounds. Investigate for possible overloading. Replace fuse or reset circuit breakers after fault is corrected.
2. Supply voltage may be too low. Check it with a volt meter.
3. Control system may be faulty. Check control for correct wiring of thermostat or aquastat and check the 24 volt transformer for proper voltage.
4. Wires may be loose or broken. Replace or tighten.
5. The low pressure switch may have tripped due to one or more of the following:
  - a) Heating
    - 1) Plugged heat exchanger on source side
    - 2) Water flow source side - (Low)
    - 3) Water too cold source side
    - 4) Low refrigerant
  - b) Cooling
    - 1) Plugged heat exchanger on load side
    - 2) Water flow load side - (Low)
    - 3) Water too cold load side
    - 4) Low refrigerant
6. The high pressure switch may have tripped due to one or more of the following:
  - a) Heating
    - 1) Plugged heat exchanger on load side
    - 2) Low water flow load side
    - 3) Water too warm load side
  - b) Cooling
    - 1) Plugged heat exchanger on source side
    - 2) Low water flow on source side
    - 3) Water too warm source side
7. The compressor overload protection may be open.
8. The internal winding of the compressor motor may be grounded to the compressor shell. If so, replace the compressor.
9. The compressor winding may be open or shorted. Disconnect power. Check continuity with ohm meter. If the winding is open, replace the compressor.

### If sufficient cooling or heating is not obtained:

1. Check control for improper location or setting.
2. Check for restriction in water flow.
3. Check refrigerant subcooling and superheat for proper refrigerant charge and expansion valve operation.
4. The reversing valve may be defective and creating a bypass of refrigerant. If the unit will not heat, check the reversing valve coil.

### If the unit operation is noisy:

1. Check compressor for loosened mounting bolts. Make sure compressor is floating free on its isolator mounts. Check for tubing contact with the compressor or other surfaces. Readjust it by bending slightly.
2. Check screws on all panels.
3. Check for chattering or humming in the contactor or relays due to low voltage or a defective holding coil. Replace the component.
4. Check for proper installation of vibration absorbing material under the unit.
5. Check for abnormally high discharge pressures.
6. Compressor rotation incorrect

## Refrigerant Systems

To maintain sealed circuit integrity, do not install service gauges unless unit operation appears abnormal. Compare the change in temperature on the air side as well as the water side to the Operating Parameters tables. If the unit's performance is not within the ranges listed, and the airflow and water flow are known to be correct, gauges should then be installed and superheat and subcooling numbers calculated. If superheat and subcooling are outside recommended ranges, an adjustment to the refrigerant charge may be necessary.

**NOTE:** Refrigerant tests must be made with hot water generator turned "OFF". Verify that air and water flow rates are at proper levels before servicing the refrigerant circuit.

# Startup and Troubleshooting Form

Company Name: \_\_\_\_\_  
 Technician Name: \_\_\_\_\_  
 Model No: \_\_\_\_\_  
 Owner's Name: \_\_\_\_\_  
 Installation Address: \_\_\_\_\_

Company Phone No: \_\_\_\_\_  
 Date: \_\_\_\_\_  
 Serial No: \_\_\_\_\_  
 Open or Closed Loop: \_\_\_\_\_  
 Installation Date: \_\_\_\_\_

Check One

Start up/Check-out for new installation       Troubleshooting      Problem: \_\_\_\_\_

1. FLOW RATE IN GPM (COAXIAL HEAT EXCHANGER)

Water In Pressure:                      a. \_\_\_\_\_ PSI  
 Water Out Pressure:                    b. \_\_\_\_\_ PSI  
 Pressure Drop = a - b                    c. \_\_\_\_\_ PSI  
 Convert Pressure Drop to Flow Rate  
 (refer to *Pressure Drop* table)              d. \_\_\_\_\_ GPM

2. TEMPERATURE RISE OR DROP ACROSS COAXIAL HEAT EXCHANGER

	COOLING	HEATING
Water In Temperature:	e. _____ °F	e. _____ °F
Water Out Temperature:	f. _____ °F	f. _____ °F
Temperature Difference:	g. _____ °F	g. _____ °F

3. TEMPERATURE RISE OR DROP ACROSS AIR COIL

	COOLING	HEATING
Air In Temperature:	h. _____ °F	h. _____ °F
Air Out Temperature:	i. _____ °F	i. _____ °F
Temperature Difference:	j. _____ °F	j. _____ °F

4. HEAT OF REJECTION (HR) / HEAT OF EXTRACTION (HE) CALCULATION

HR or HE = Flow Rate x Temperature Difference x Brine Factor\*  
 d. (above) x g. (above) x 485 for Methanol or Environol, 500 for water\*  
 Heat of Extraction (Heating Mode) = \_\_\_\_\_ btu/hr  
 Heat of Rejection (Cooling Mode) = \_\_\_\_\_ btu/hr  
 Compare results to Capacity Data Tables

Note: Steps 5 through 8 need only be completed if a problem is suspected

5. WATTS

	COOLING	HEATING
Volts:	m. _____ VOLTS	m. _____ VOLTS
Total Amps (Comp. + Fan):	n. _____ AMPS	n. _____ AMPS
Watts = m. x n. x 0.85	o. _____ WATTS	o. _____ WATTS

6. CAPACITY

Cooling Capacity = HR. - (o. x 3.413)                      p. \_\_\_\_\_ btu/hr  
 Heating Capacity = HE. + (o. x 3.413)                      p. \_\_\_\_\_ btu/hr

7. EFFICIENCY

Cooling EER = p. / o.    q. \_\_\_\_\_ EER  
 Heating COP = p. / (o. x 3.413)                                      q. \_\_\_\_\_ COP

8. SUPERHEAT (S.H.) / SUBCOOLING (S.C.)

	COOLING	HEATING
Suction Pressure:	r. _____ PSI	r. _____ PSI
Suction Saturation Temperature:	s. _____ °F	s. _____ °F
Suction Line Temperature:	t. _____ °F	t. _____ °F
Superheat = t. - s.	u. _____ °F	u. _____ °F
Head Pressure:	v. _____ PSI	v. _____ PSI
High Pressure Saturation Temp.:	w. _____ °F	w. _____ °F
Liquid Line Temperature*:	x. _____ °F	x. _____ °F
Subcooling = w. - x.	y. _____ °F	y. _____ °F

\* Note: Liquid line is between the coaxial heat exchanger and the expansion valve in the cooling mode; between the air coil and the expansion valve in the heating mode.

DEALER: \_\_\_\_\_  
 PHONE #: \_\_\_\_\_ DATE: \_\_\_\_\_  
 PROBLEM: \_\_\_\_\_  
 MODEL #: \_\_\_\_\_  
 SERIAL #: \_\_\_\_\_

**Startup/Troubleshooting Form**

**COOLING CYCLE ANALYSIS**

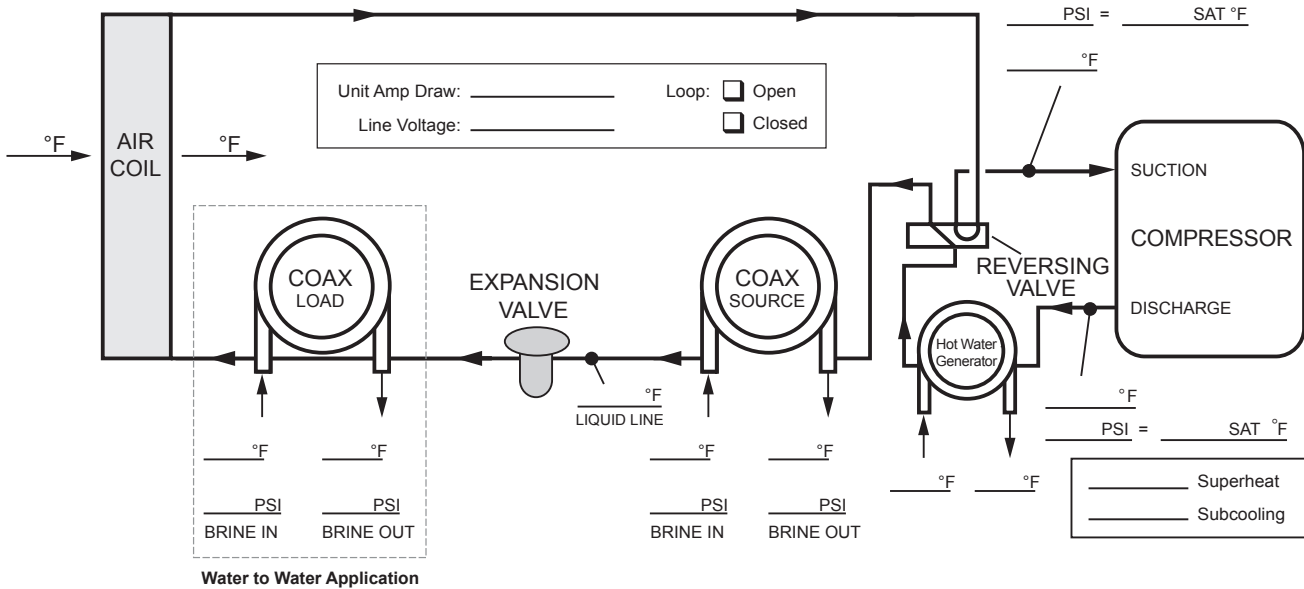

**Heat of Extraction/Rejection = GPM x 500 (485 for water/antifreeze) x ΔT**

**Note: DO NOT** hook up pressure gauges unless there appears to be a performance problem.

**HEATING CYCLE ANALYSIS**

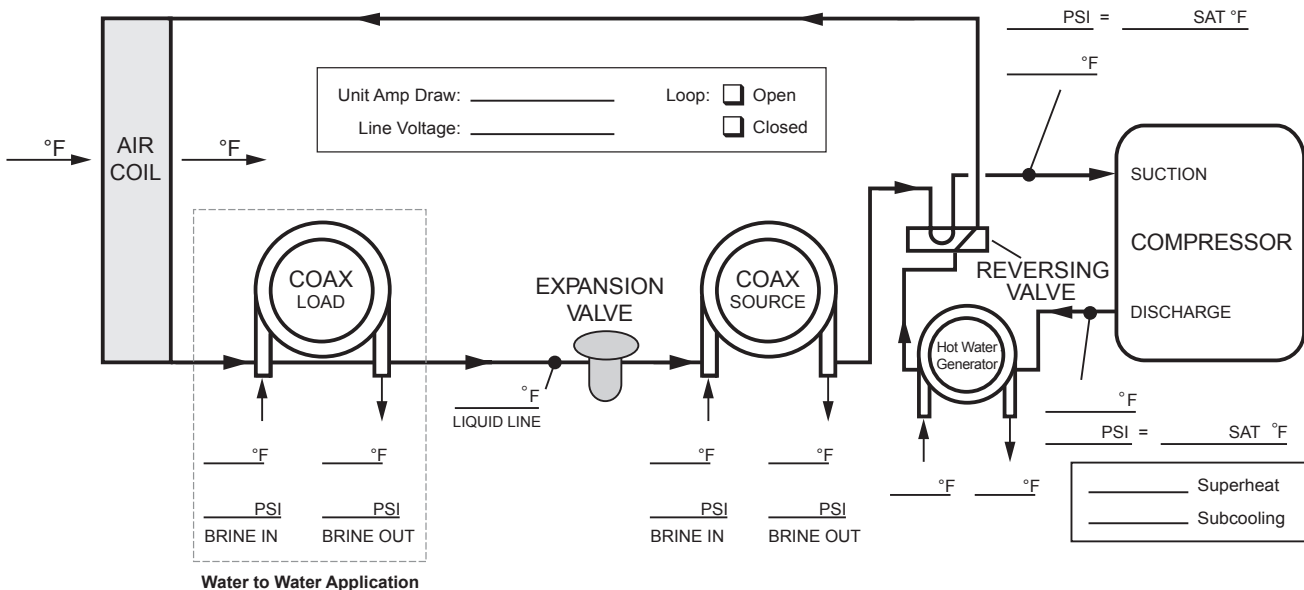



---

## Preventive Maintenance

---

### Water Coil Maintenance

1. Keep all air out of the water. An open loop system should be checked to ensure that the well head is not allowing air to infiltrate the water line. Lines should always be airtight.
2. Keep the system under pressure at all times. It is recommended in open loop systems that the water control valve be placed in the discharge line to prevent loss of pressure during off cycles. Closed loop systems must have positive static pressure.

**NOTE:** On open loop systems, if the installation is in an area with a known high mineral content (125 PPM or greater) in the water, it is best to establish with the owner a periodic maintenance schedule so the coil can be checked regularly. Should periodic coil cleaning be necessary, use standard coil cleaning procedures which are compatible with either the cupronickel or copper water lines. Generally, the more water flowing through the unit the less chance for scaling.

### Other Maintenance

#### Filters

Filters must be clean to obtain maximum performance. They should be inspected monthly under normal operating conditions and be replaced when necessary. Units should never be operated without a filter.

#### Condensate Drain

In areas where airborne bacteria produce a slime in the drain pan, it may be necessary to treat chemically to minimize the problem. The condensate drain can pick up lint and dirt, especially with dirty filters. Inspect twice a year to avoid the possibility of overflow.

#### Blower Motors

Blower motors are equipped with sealed ball bearings and require no periodic oiling.

#### Hot Water Generator Coil

See Water Coil Maintenance section above.

#### Air Coil

The air coil must be cleaned to obtain maximum performance. Check once a year under normal operating conditions and, if dirty, brush or vacuum (with a brush attachment) clean. Care must be taken not to damage the aluminum fins while cleaning.



**CAUTION: Fin edges are sharp.**

---

## Replacement Procedures

---

### Obtaining Parts

When ordering service or replacement parts, refer to the model number and serial number of the unit as stamped on the serial plate attached to the unit. If replacement parts are required, mention the date of installation of the unit and the date of failure, along with an explanation of the malfunctions and a description of the replacement parts required.

### In-Warranty Material Return

Material may not be returned except by permission of authorized warranty personnel. Contact your local distributor for warranty return authorization and assistance.

## Revision Guide

<b>Pages:</b>	<b>Description:</b>	<b>Date:</b>	<b>By:</b>
Misc	Updated wiring schematics	30 Nov 2018	MA
Misc.	Updated Nomenclature, Removed FX10	27 May 2016	JM
2, 45	Updated ETL Logo, Updated Pressure Drop Data	18 May 2015	MA
All	Updated with Aluminum Air Coils	29 Oct 2013	DS
19-21	Updated Compressor LRA with GeoStart	31 Jul 2013	DS
53-54	Updated Service Parts Guide with GeoStart Compatibility	31 Jul 2013	DS
All	Updated Nomenclature to Reflect New Variable Speed ECM Motor	13 Feb 2012	DS
All	Updated Nomenclature to Reflect New 5-Speed ECM Motor	13 Feb 2012	DS
All	Updated Nomenclature to Reflect New Aurora Controls	13 Feb 2012	DS
53-54	Updated Service Parts Lists	13 Feb 2012	DS
55	Added Revision Guide	13 Feb 2012	DS

## Notes

---



Product: **Arbor Series Series**  
Type: Geothermal/Water Source Heat Pumps  
Size: 0.75-6 Ton

Document Type: Installation Manual  
Part Number: IM1200AZB  
Release Date: 11/18