

G Series

Water Source/Geothermal Heat Pump

- Commercial
- 7-25 Tons

Installation Information

Water Piping Connections

Electrical Connections

Startup Procedures

Preventive Maintenance



G Series 7-25 Tons Installation Manual



Table of Contents

Model Nomenclature	4
General Installation Information	5
Vertical Dimensions	6-7
Horizontal Dimensions	8
Installing Horizontal Units	9-10
Installing Vertical Units	11
Water Quality	12
System Cleaning and Flushing	13
Electrical Connections	14
Electrical Data	15
Blower Performance Data	16-25
Wiring Schematics	26-27
Optional FX10 Microprocessor Control	28-37
Blower Drive Sheaves	38
Unit Startup	39
Operating Parameters	40
Pressure Drop	40
Startup/Troubleshooting Form	41
Preventive Maintenance	42
Replacement Procedures	42

Model Nomenclature

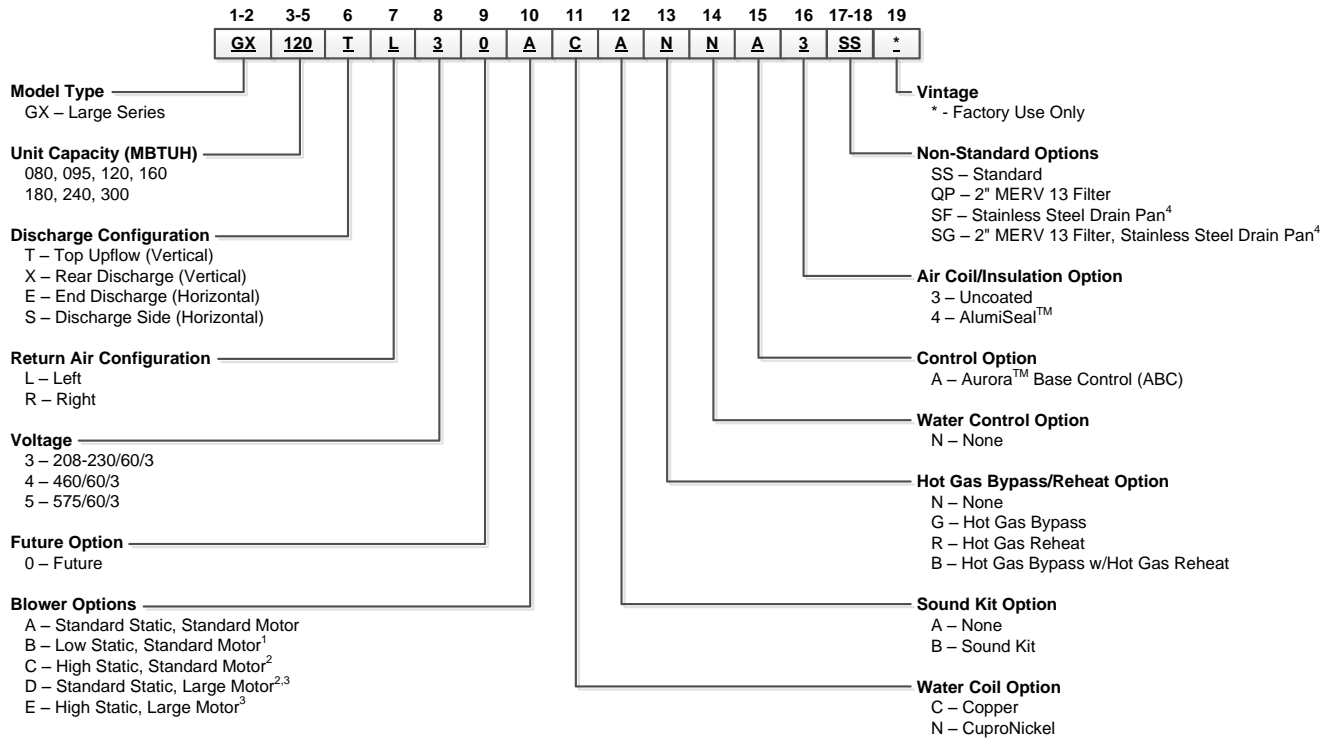

Notes:

- 1 – Not available on vertical GX095, 180, horizontal GX080
- 2 – Not available on vertical GX080, 160
- 3 – Not available on horizontal GX120, vertical GX300
- 4 – Not available on vertical GX160-300. Stainless steel is standard on vertical GX160-300

Rev.: 18 May 2015D

General Installation Information

Safety Considerations



WARNING: Before performing service or maintenance operations on a system, turn off main power switches to the indoor unit. If applicable, turn off the accessory heater power switch. Electrical shock could cause personal injury.

Installing and servicing heating and air conditioning equipment can be hazardous due to system pressure and electrical components. Only trained and qualified service personnel should install, repair or service heating and air conditioning equipment. Untrained personnel can perform the basic maintenance functions of cleaning coils and cleaning and replacing filters. All other operations should be performed by trained service personnel. When working on heating and air conditioning equipment, observe precautions in the literature, tags and labels attached to the unit and other safety precautions that may apply.

Follow all safety codes. Wear safety glasses and work gloves. Use a quenching cloth for brazing operations and have a fire extinguisher available.

Moving and Storage

Move units in the normal “up” orientation. Horizontal units may be moved and stored per the information on the packaging. Do not stack more than three units in total height. Vertical units may be stored one upon another to a maximum height of two units. Do not attempt to move units while stacked. When the equipment is received, all items should be carefully checked against the bill of lading to be sure all crates and cartons have been received. Examine units for shipping damage, removing the units from the packaging if necessary. Units in question should also be internally inspected. If any damage is noted, the carrier should make the proper notation on the delivery receipt, acknowledging the damage.

Unit Location

Locate the unit in an indoor area that allows for easy removal of the filter and access panels. Location should have enough space for service personnel to perform maintenance or repair. Provide sufficient room to make water, electrical and duct connection(s). If the unit is located in a confined space, such as a closet, provisions must be made for return air to freely enter the space by means of a louvered door, etc. Any access panel screws that would be difficult to remove after the unit is installed should be removed prior to setting the unit. On horizontal units, allow adequate room below the unit for a condensate drain trap and do not locate the unit above supply piping. Care should be taken when units are located in unconditioned spaces to prevent damage from frozen water lines and excessive heat that could damage electrical components.

Installing Vertical Units

Prior to setting the unit in place, remove and discard the compressor hold down shipping bolt located at the front of the compressor mounting bracket.

Vertical units are available in left or right air return configurations. Top flow vertical units should be mounted level on a vibration absorbing pad slightly larger than the base to provide isolation between the unit and the floor. It is not necessary to anchor the unit to the floor (see right).

Figure 1: Vertical Unit Mounting
(GX080-300)

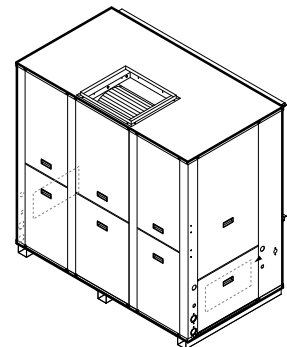

Vertical Dimensions

7-10 Tons

TOP DISCHARGE

SIDE DISCHARGE

Legend
 AP = Alternate Service Panel
 BP = Blower Service Panel
 CP = Control Access Panel
 CMP = Compressor Service Panel

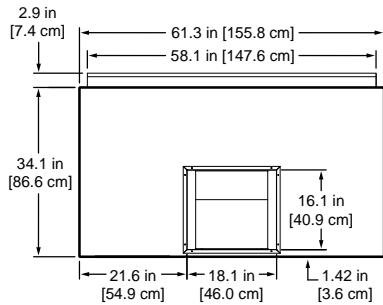
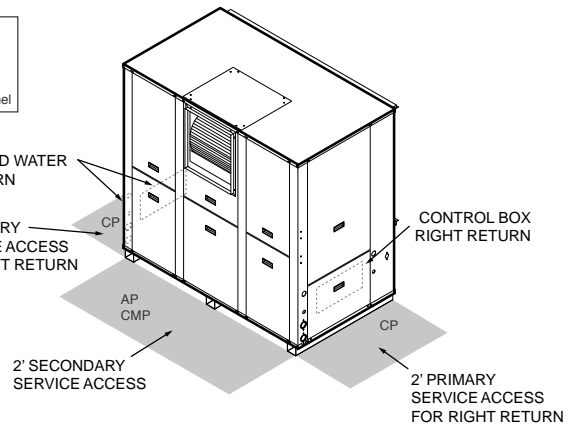
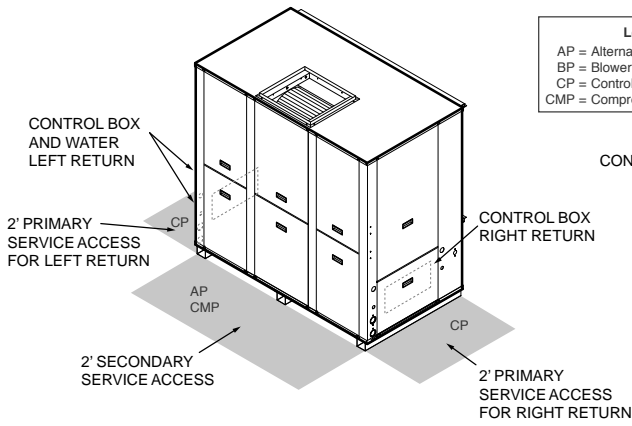

TOP VIEW
Left or Right Return

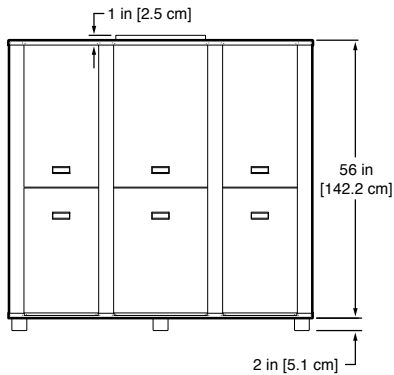
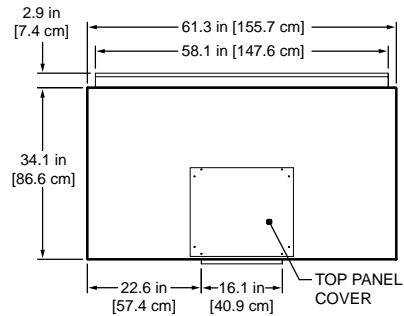

SIDE VIEW
Left or Right Return

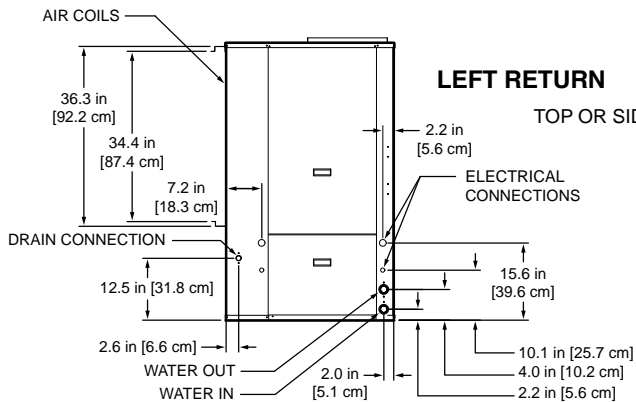
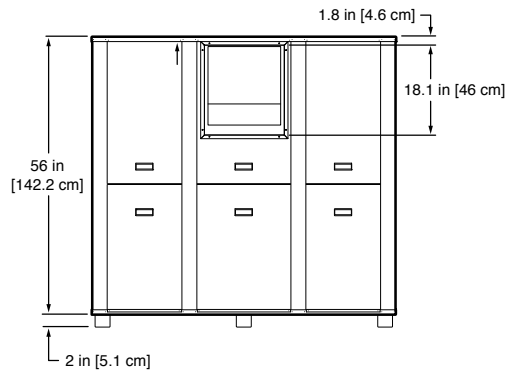

LEFT RETURN

RIGHT RETURN

TOP OR SIDE DISCHARGE

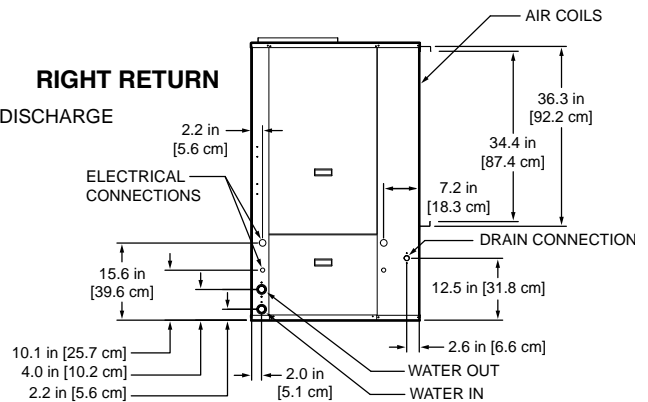

Vertical Dimensions cont.

13-25 Tons

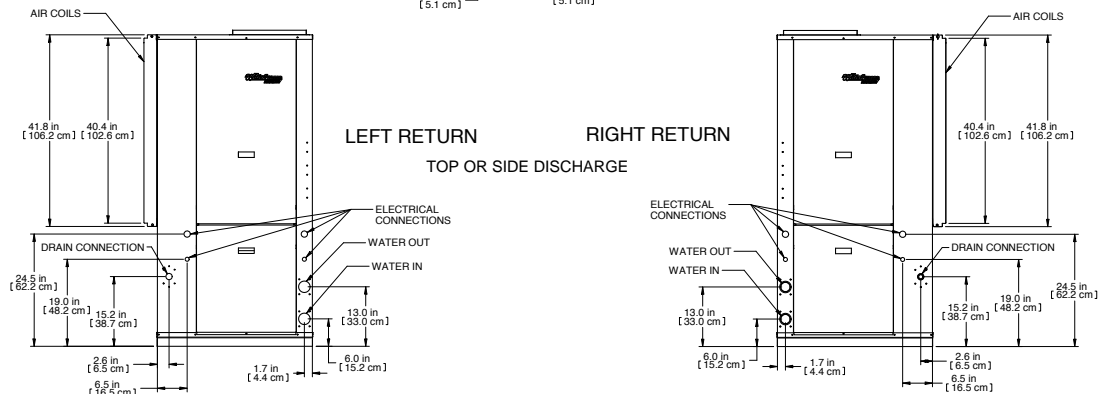
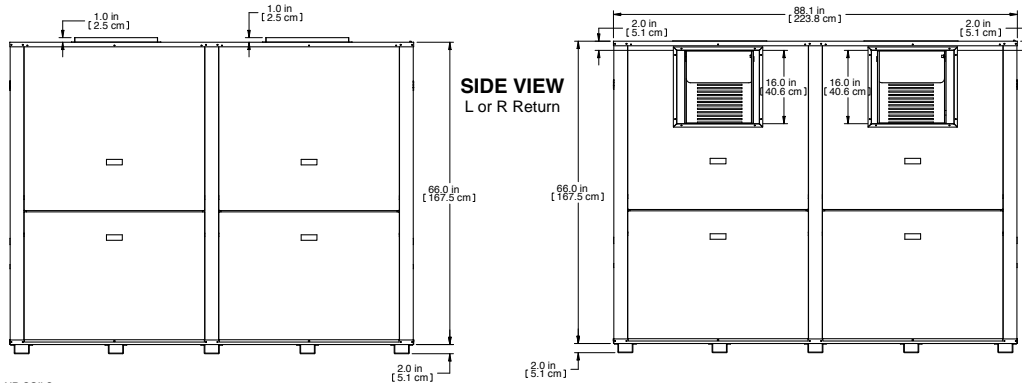
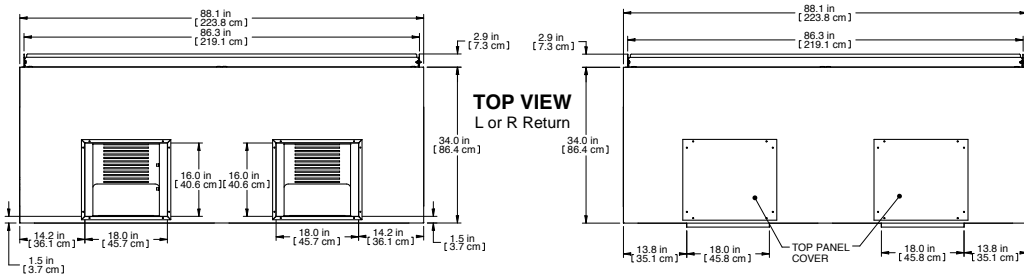
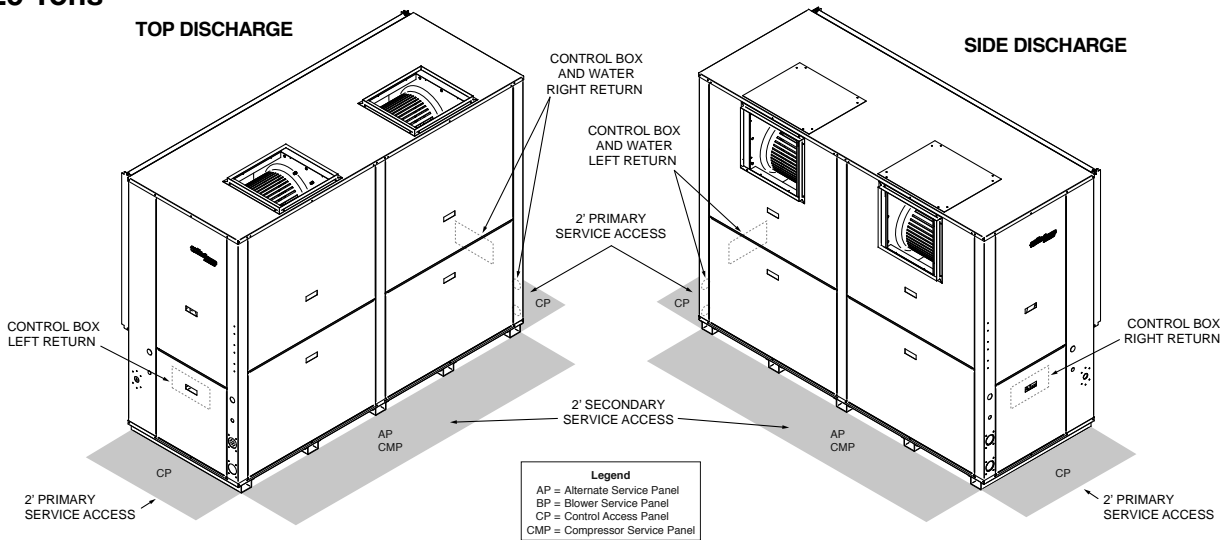

Horizontal Dimensions

7-10 Tons

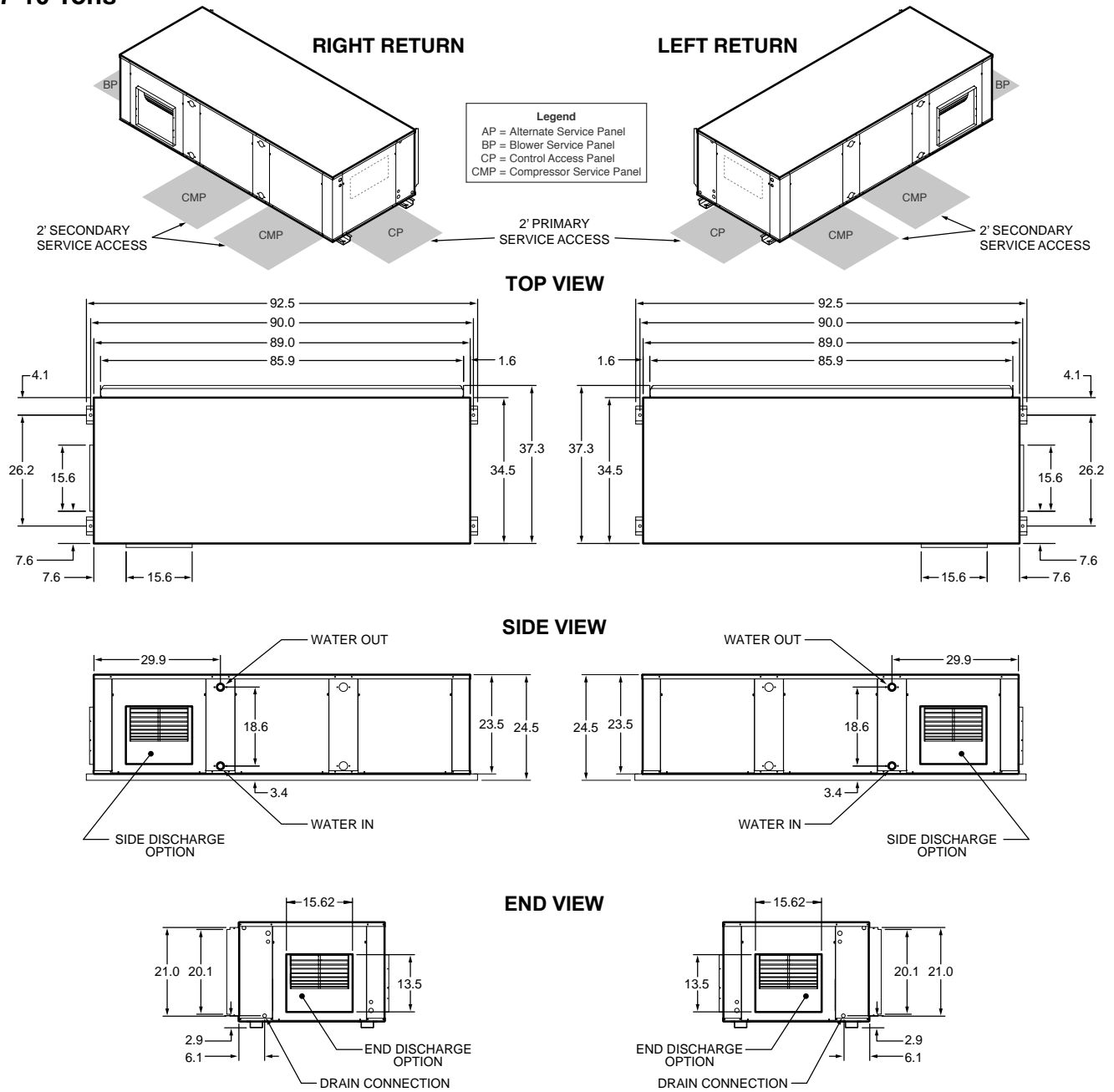

REV 4/28/08

Installing Horizontal Units

Mounting Horizontal Units

Units are available with side or end discharge in left-hand or right-hand return air configurations. Horizontal units are normally suspended from a ceiling by four 1/2 in. diameter threaded rods. The rods are usually attached to the unit corners by the bottom panel mounting channel and the mounting grommets furnished with each unit.



CAUTION: Do not use rods smaller than 1/2 in. diameter since they may not be strong enough to support the unit. The rods must be securely anchored to the ceiling (the units are approximately 800 lbs.).

Figure 1: Typical Horizontal Application

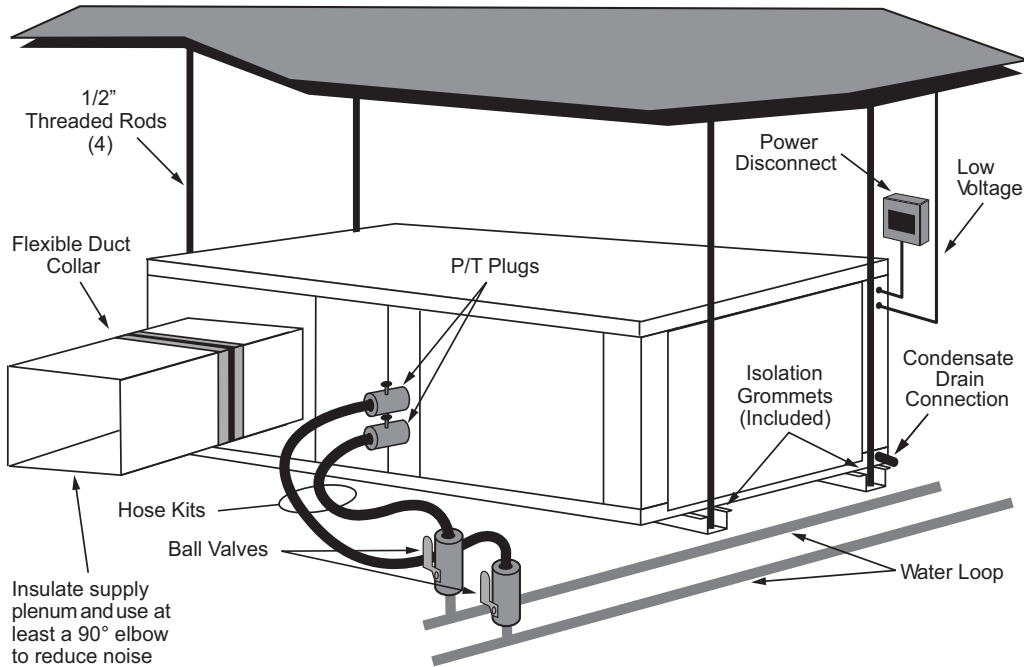

Layout the threaded rods per the dimensions in Figure 2. Assemble the hangers to the unit as shown in Figure 3. Securely tighten the brackets to the unit. When attaching the hanger rods to the bracket, a double nut is recommended since vibration could loosen a single nut. The unit should be pitched approximately 1/2 in. towards the drain in both directions, to facilitate condensate removal.

Figure 2: Mounting Rod Layout

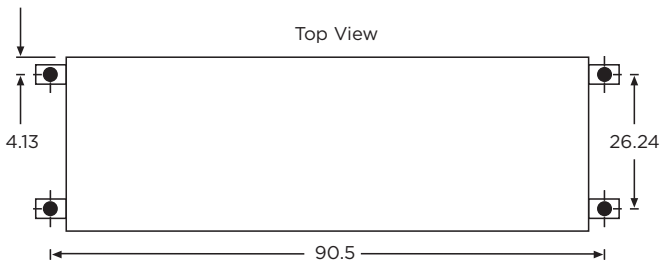
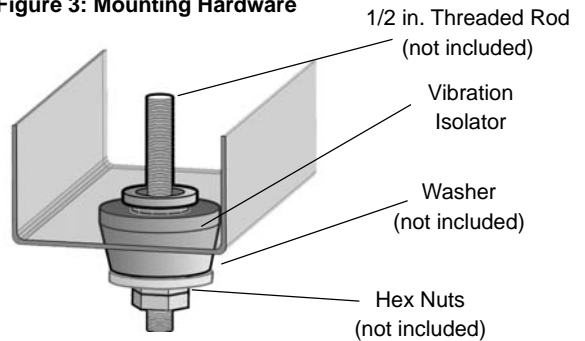

Figure 3: Mounting Hardware



Installing Horizontal Units cont.

Horizontal Unit Corner Weight Distribution

Model	Return / Discharge	A Front Left	B Front Right	C Back Right	D Back Left
080 - 120	Left / Side or End	30%	26%	22%	22%
	Right / Side or End	26%	30%	22%	22%

Approximate

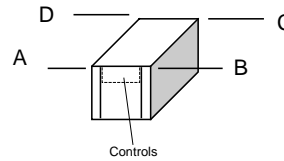

Duct System

An air outlet collar is provided on vertical top flow units and all horizontal units to facilitate a duct connection. A flexible connector is recommended for discharge and return air duct connections on metal duct systems. Uninsulated duct should be insulated with a minimum of 1-inch duct insulation. Application of the unit to uninsulated ductwork in an unconditioned space is not recommended as the unit's performance will be adversely affected.

If the unit is connected to existing ductwork, check the duct system to ensure that it has the capacity to accommodate the air required for the unit application. If the duct is too small, as in the replacement of heating only systems, larger ductwork should be installed. All existing ductwork should be checked for leaks and repaired if necessary.

The duct system should be sized to handle the design airflow quietly and efficiently. To maximize sound attenuation of the unit blower, the supply and return plenums should include an internal duct liner of fiberglass or constructed of ductboard for the first few feet. On systems employing a sheet metal duct system, canvas connectors should be used between the unit and the ductwork. If air noise or excessive airflow is a problem, the blower speed can be changed.

Water Piping

The proper water flow must be provided to each unit whenever the unit operates. To assure proper flow, use pressure/temperature ports to determine the flow rate. These ports should be located at the supply and return water connections on the unit. The proper flow rate cannot be accurately set without measuring the water pressure drop through the refrigerant-to-water heat exchanger.

All source water connections on commercial units are fittings that accept a male pipe thread (MPT). Insert the connectors by hand, then tighten the fitting with a wrench to provide a leakproof joint. When connecting to an open loop (groundwater) system, thread any copper MPT fitting into the connector and tighten in the same manner as described above.

Figure 4: Suggested Layout of Condensate

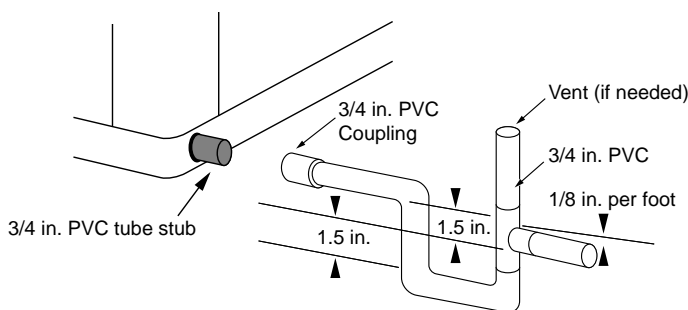
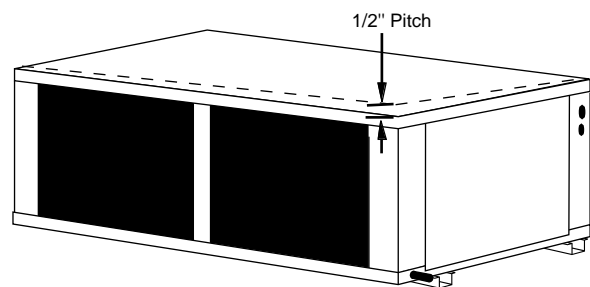

Figure 5: Unit Pitch for Drain



Installing Vertical Units

Mounting Vertical Units

Units are available with top/side discharge, left-hand or right-hand return air configurations. Vertical units are assembled on rails which facilitate moving and placement of the units. It is not necessary to anchor the unit to the floor.

Duct System

A supply air duct flange is provided for field installation to facilitate the secure duct connection at the job site. A flexible connector is recommended for discharge and return air duct connections on metal duct systems to prevent vibration transmission. It is recommended that all ductwork be insulated with a minimum of 1/2-inch coated insulation. Installation of the units with uninsulated ductwork in an unconditioned space is not recommended, as the system's performance will be adversely affected.

Condensate Drain

In vertical units, the internal condensate drain assembly consists of a flexible drain tube which is attached to the drain pan and a 3/4-inch (7-10 tons) and 1-inch (13-25 tons) female pipe thread. An external water trap is not required as the drain tube serves as a trapping loop. The field-installed piping and unit connection must be properly installed and sealed to prevent water leakage.

Figure 6: Typical Vertical Application

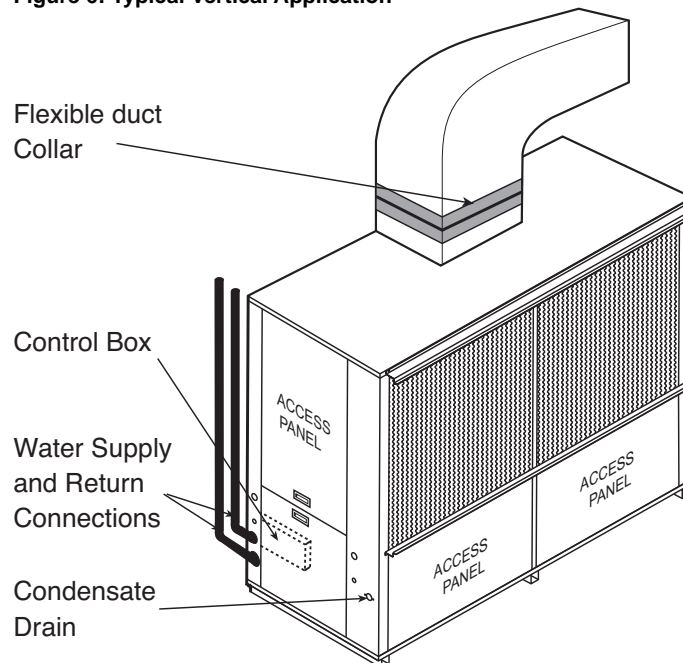

Water Quality

Water Quality Guidelines

In ground water situations where scaling could be heavy or where biological growth such as iron bacteria will be present, a closed loop system is recommended. The heat exchanger coils in ground water systems may, over a period of time, lose heat exchange capabilities due to a buildup of mineral deposits inside. These can be cleaned, but only by a qualified service mechanic, as special solutions and pumping equipment are required. Hot water generator coils can likewise become scaled and possibly plugged. In areas with extremely hard water, the owner should be informed that the heat exchanger may require occasional flushing.

Units with cupronickel heat exchangers are recommended for open loop applications due to the increased resistance to build-up and corrosion, along with reduced wear caused by acid cleaning.

Material		Copper	90/10 Cupronickel	316 Stainless Steel
pH	Acidity/Alkalinity	7 - 9	7 - 9	7 - 9
Scaling	Calcium and Magnesium Carbonate	(Total Hardness) less than 350 ppm	(Total Hardness) less than 350 ppm	(Total Hardness) less than 350 ppm
Corrosion	Hydrogen Sulfide	Less than 0.5 ppm (rotten egg smell appears at 0.5 ppm)	10 - 50 ppm	Less than 1 ppm
	Sulfates	Less than 125 ppm	Less than 125 ppm	Less than 200 ppm
	Chlorine	Less than 0.5 ppm	Less than 0.5 ppm	Less than 0.5 ppm
	Chlorides	Less than 20 ppm	Less than 125 ppm	Less than 300 ppm
	Carbon Dioxide	Less than 50 ppm	10 - 50 ppm	10 - 50 ppm
	Ammonia	Less than 2 ppm	Less than 2 ppm	Less than 20 ppm
	Ammonia Chloride	Less than 0.5 ppm	Less than 0.5 ppm	Less than 0.5 ppm
	Ammonia Nitrate	Less than 0.5 ppm	Less than 0.5 ppm	Less than 0.5 ppm
	Ammonia Hydroxide	Less than 0.5 ppm	Less than 0.5 ppm	Less than 0.5 ppm
	Ammonia Sulfate	Less than 0.5 ppm	Less than 0.5 ppm	Less than 0.5 ppm
Total Dissolved Solids (TDS)	Less than 1000 ppm	1000 - 1500 ppm	1000 - 1500 ppm	
LSI Index	+0.5 to -0.5	+0.5 to -0.5	+0.5 to -0.5	
Iron Fouling (Biological Growth)	Iron, FE ²⁺ (Ferrous) Bacterial Iron Potential	< 0.2 ppm	< 0.2 ppm	< 0.2 ppm
	Iron Oxide	Less than 1 ppm, above this level deposition will occur	Less than 1 ppm, above this level deposition will occur	Less than 1 ppm, above this level deposition will occur
Erosion	Suspended Solids	Less than 10 ppm and filtered for max. of 600 micron size	Less than 10 ppm and filtered for max. of 600 micron size	Less than 10 ppm and filtered for max. of 600 micron size
	Threshold Velocity (Fresh Water)	< 6 ft/sec	< 6 ft/sec	< 6 ft/sec

Water Connections

All supply and return water connections are female pipe thread of size specified in physical dimensions. Never use flexible hoses smaller than separate water connections on the unit and limit hose length to 10 ft. per connection. Check carefully for water leaks.

Interior Piping

All units are recommended to be connected to supply and return piping in a two-pipe reverse return configuration. A reverse return system is inherently self-balancing and requires only trim balancing when multiple quantities of units with different flow and pressure drop characteristics are connected to the same loop. A direct return system may also be made to work acceptably, but proper water flow balance is more difficult to achieve and maintain.

Supply and return runouts are usually connected to the unit by short lengths of high pressure flexible hose which are sound attenuators for both unit operating noise and hydraulic pumping noise. One end of the hose should have a swivel fitting to facilitate removal for service. Hard piping can also be connected directly to the unit although it is not recommended since no vibration or noise attenuation can be accomplished. The hard piping must have unions to facilitate unit removal (see figure 1 & 6) for typical application).

Some flexible hose threaded fittings are supplied with sealant compound. If not, apply Teflon tape to assure a tight seal.

Supply and return shutoff valves are required at each unit. The return shutoff valve can be used for balancing and should be adjusted for proper flow required, or a manual or automatic flow control device should be on the leaving water hose assembly.

No unit should be connected to the supply and return piping until the water system has been cleaned and flushed completely. After the cleaning and flushing has taken place, the initial connection should have all valves wide open in preparation for water system filling.

System Cleaning and Flushing

Cleaning and Flushing

Prior to start up of any heat pump, the water circulating system must be cleaned and flushed of all dirt and debris.

If the system is equipped with water shutoff valves, the supply and return runouts must be connected together at each unit location (This will prevent the introduction of dirt into the unit, see Figure 7). The system should be filled at the water make-up connection with all air vents open. After filling, vents should be closed.

The contractor should start the main circulator with the pressure reducing valve makeup open. Vents should be checked in sequence to bleed off any trapped air and to verify circulation through all components of the system.

As water circulates through the system, the contractor should check and repair any leaks found in the piping system. Drain(s) at the lowest point(s) in the system should be opened for initial flush and blowdown, making sure water fill valves are set at the same rate. Check the pressure gauge at the pump suction and manually adjust the make-up water valve to hold the same positive pressure both before and after opening the drain valves. Flushing should continue for at least two hours, or longer if required, until drain water is clean and clear.

The supplemental heater and/or circulator pump, if used, should be shut off. All drains and vents should be opened to completely drain the system. Short-circuited supply and return runouts should now be connected to the unit supply and return connections.

Refill the system with clean water. Test the system water for acidity and treat as required to leave the water slightly alkaline (pH 7.5 to 8.5). The specified percentage of antifreeze may also be added at this time. Use commercial grade antifreeze designed for HVAC systems only. Environol™ brand antifreeze is recommended..

Once the system has been filled with clean water and antifreeze (if used), precautions should be taken to protect the system from dirty water conditions. Dirty water will result in system-wide degradation of performance, and solids may clog valves, strainers, flow regulators, etc. Additionally, the heat exchanger may become clogged which reduces compressor service life and can cause premature unit failure.

In boiler/tower application, set the loop control panel set points to desired temperatures. Supply power to all motors and start the circulating pumps. After full flow has been established through all components including the heat rejector (regardless of season), air vented and loop temperatures stabilized, each of the units will be ready for check, test and start up and for air and water balancing.

Ground Source Loop System Checkout

Once piping is completed between the unit pumping system and ground loop, final purging and charging of the loop is needed. A high pressure pump is needed to achieve adequate flow velocity in the loop to purge air and dirt particles from the loop itself. Antifreeze solution is used in most areas to prevent freezing. Flush the system adequately to remove as much air as possible; then pressurize the loop to a static pressure of 40-50 PSI (summer) or 50-75 PSI (winter). This is normally adequate for good system operation. Loop static pressure may decrease soon after initial installation, due to pipe expansion and loop temperature change. Running the unit for at least 30 minutes after the system has been completely purged of air will allow for the “break-in” period. It may be necessary to adjust static loop pressure (by adding water) after the unit has run for the first time. Loop static pressure will also fluctuate with the seasons. Pressures will be higher in the winter months than during the cooling season. This fluctuation is normal and should be considered when charging the system initially.

Ensure the pump provides adequate flow through the unit by checking pressure drop across the heat exchanger. Usually 2.25-3.0 GPM of flow per ton of cooling capacity is recommended in earth loop applications.

Figure 7: Flushing with Water Shutoff Valve Equipped Systems

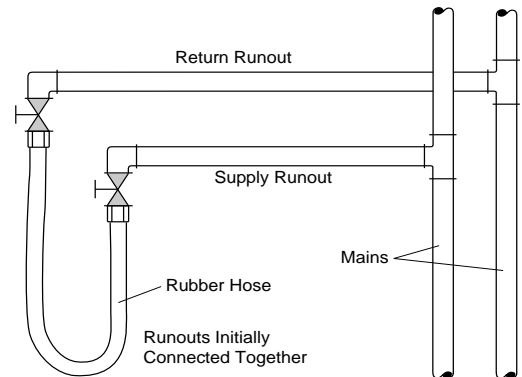

Electrical Connections

General

Be sure the available power is the same voltage and phase as that shown on the unit serial plate. Line and low voltage wiring must be done in accordance with local codes or the National Electric Code.

Unit Power Connection

Line voltage connection is made by connecting the incoming line voltage wires to the terminal block as shown on the unit's wiring diagram attached to the inside front panel. Consult the Unit Electrical Data below for correct fuse size.

208 Volt Operation

NOTE: All 208-230 volt units are factory wired for 230 volt operation. For 208 volt operation, the red and the blue transformer wires must be switched between terminal strip PS and contactor RB.

Electrical Data

Model	Rated Voltage	Voltage Min/Max	Compressor*			Blower Motor FLA***	Blower HP ***	Total Unit FLA	Min Circ Amp	Max Fuse/HACR
			MCC	RLA	LRA					
Horizontal										
080	208-230/60/3	187/253	16.3	10.4	88.0	4.8	1.5	25.7	28.3	35.0
	460/60/3	414/506	9.0	5.8	38.0	2.4	1.5	13.9	15.4	20.0
	575/60/3	518/632	5.9	3.8	36.5	1.9	1.5	9.5	10.4	10.0
080**	208-230/60/3	187/253	16.3	10.4	88.0	6.2	2.0	27.1	29.7	40.0
	460/60/3	414/506	9.0	5.8	38.0	3.1	2.0	14.6	16.1	20.0
	575/60/3	518/632	5.9	3.8	36.5	2.5	2.0	10.1	11.0	10.0
095	208-230/60/3	187/253	21.2	13.6	83.1	6.2	2.0	33.3	36.7	50.0
	460/60/3	414/506	9.5	6.1	41.0	3.1	2.0	15.3	16.8	20.0
	575/60/3	518/632	7.8	5.0	34.0	2.5	2.0	12.5	13.7	15.0
095**	208-230/60/3	187/253	21.2	13.6	83.1	9.2	3.0	36.3	39.7	50.0
	460/60/3	414/506	9.5	6.1	41.0	4.3	3.0	16.5	18.0	20.0
	575/60/3	518/632	7.8	5.0	34.0	3.4	3.0	13.4	14.6	15.0
120	208-230/60/3	187/253	24.9	15.9	110.0	9.2	3.0	41.1	45.1	60.0
	460/60/3	414/506	12.1	7.7	52.0	4.3	3.0	19.8	21.7	25.0
	575/60/3	518/632	8.9	5.7	38.9	3.4	3.0	14.8	16.2	20.0
Vertical										
080	208-230/60/3	187/253	16.3	10.4	88.0	3.6	1.0	24.5	27.1	35.0
	460/60/3	414/506	9.0	5.8	38.0	1.8	1.0	13.3	14.8	20.0
	575/60/3	518/632	5.9	3.8	36.5	1.5	1.0	9.0	9.9	10.0
080**	208-230/60/3	187/253	16.3	10.4	88.0	4.8	1.5	25.7	28.3	35.0
	460/60/3	414/506	9.0	5.8	38.0	2.4	1.5	13.9	15.4	20.0
	575/60/3	518/632	5.9	3.8	36.5	1.9	1.5	9.5	10.4	10.0
095	208-230/60/3	187/253	21.2	13.6	83.1	4.8	1.5	31.9	35.3	45.0
	460/60/3	414/506	9.5	6.1	41.0	2.4	1.5	14.6	16.1	20.0
	575/60/3	518/632	7.8	5.0	34.0	1.9	1.5	11.9	13.1	15.0
095**	208-230/60/3	187/253	21.2	13.6	83.1	6.2	2.0	33.3	36.7	50.0
	460/60/3	414/506	9.5	6.1	41.0	3.1	2.0	15.3	16.8	20.0
	575/60/3	518/632	7.8	5.0	34.0	2.5	2.0	12.5	13.7	15.0
120	208-230/60/3	187/253	24.9	15.9	110.0	6.2	2.0	38.1	42.1	50.0
	460/60/3	414/506	12.1	7.7	52.0	3.1	2.0	18.6	20.5	25.0
	575/60/3	518/632	8.9	5.7	38.9	2.5	2.0	13.9	15.3	20.0
120**	208-230/60/3	187/253	24.9	15.9	110.0	9.2	3.0	41.1	45.1	60.0
	460/60/3	414/506	12.1	7.7	52.0	4.3	3.0	19.8	21.7	25.0
	575/60/3	518/632	8.9	5.7	38.9	3.4	3.0	14.8	16.2	20.0
160	208-230/60/3	187/253	35.0	22.4	149.0	3.6	1.0	52.0	57.6	80.0
	460/60/3	414/506	16.5	10.6	75.0	1.8	1.0	24.8	54.0	35.0
	575/60/3	518/632	12.0	7.7	54.0	1.5	1.0	18.4	20.3	25.0
160**	208-230/60/3	187/253	35.0	22.4	149.0	4.8	1.5	54.4	60.0	80.0
	460/60/3	414/506	16.5	10.6	75.0	2.4	1.5	26.0	28.7	35.0
	575/60/3	518/632	12.0	7.7	54.0	1.9	1.5	19.2	21.1	25.0
180	208-230/60/3	187/253	36.2	23.2	164.0	4.8	1.5	56.0	61.8	80.0
	460/60/3	414/506	17.5	11.2	75.0	2.4	1.5	27.2	30.0	40.0
	575/60/3	518/632	12.3	7.9	54.0	1.9	1.5	19.6	21.6	25.0
180**	208-230/60/3	187/253	36.2	23.2	164.0	6.2	2.0	58.8	64.6	80.0
	460/60/3	414/506	17.5	11.2	75.0	3.1	2.0	28.6	31.4	40.0
	575/60/3	518/632	12.3	7.9	54.0	2.5	2.0	20.8	22.8	30.0
240	208-230/60/3	187/253	47.0	30.1	225.0	6.2	2.0	72.6	80.1	110.0
	460/60/3	414/506	26.0	16.6	114.0	3.1	2.0	39.5	43.6	60.0
	575/60/3	518/632	19.0	12.2	80.0	2.5	2.0	29.3	32.4	40.0
240**	208-230/60/3	187/253	47.0	30.1	225.0	9.2	3.0	78.6	86.1	110.0
	460/60/3	414/506	26.0	16.6	114.0	4.3	3.0	41.9	46.0	60.0
	575/60/3	518/632	19.0	12.2	80.0	3.4	3.0	31.1	34.2	45.0
300	208-230/60/3	187/253	52.0	33.3	239.0	9.2	3.0	85.0	93.3	125.0
	460/60/3	414/506	28.0	17.9	125.0	4.3	3.0	44.4	48.9	60.0
	575/60/3	518/632	20.0	12.8	80.0	3.4	3.0	32.4	35.6	45.0

*Ratings per each compressor - unit supplied with two

9/10/07

**With optional motor

***Ratings per each blower motor - Vertical models 160-300 supplied with two.

HACR circuit breaker in USA only

All fuses Class RK-5

Horizontal GX080 - Blower Performance Data

Belt Drive

Airflow in CFM with dry coil and clean air filter.

Rated CFM		External Static Pressure (in. w.g.)																
		0.0	0.1	0.2	0.3	0.4	0.5	0.6	0.7	0.8	0.9	1.0	1.1	1.2	1.3	1.4	1.5	
2200	MTR/SHEAVE				1.0	1.0	1.0	1.0	1.0	4.0	4.0	4.0	4.0	5.0	5.0	5.0	5.0	
	BHP				0.37	0.40	0.43	0.47	0.52	0.59	0.65	0.71	0.75	0.78	0.81	0.86	0.90	
	RPM				583	624	665	706	747	770	791	821	865	911	957	986	1015	
	URNS OPEN				5.0	4.0	3.0	2.0	1.0	3.0	2.0	1.0	0.0	3.5	3.0	2.5	2.0	
2400	MTR/SHEAVE			1.0	1.0	1.0	1.0	1.0	4.0	4.0	4.0	4.0	5.0	5.0	5.0	5.0		
	BHP				0.45	0.49	0.53	0.59	0.62	0.67	0.70	0.74	0.79	0.85	0.88	0.91	0.95	1.08
	RPM				582	623	664	705	746	765	790	820	861	906	938	970	1004	1030
	URNS OPEN				5.0	4.0	3.0	2.0	1.0	3.0	2.0	1.0	0.0	4.0	3.0	2.5	2.0	1.5
2600	MTR/SHEAVE			1.0	1.0	1.0	1.0	3.0	3.0	3.0	3.0	3.0	5.0	5.0	5.0	5.0	5.0	
	BHP				0.51	0.56	0.62	0.66	0.69	0.73	0.76	0.84	0.90	0.93	0.96	1.04	1.12	1.17
	RPM				602	643	684	726	760	783	805	853	877	916	954	988	1021	1051
	URNS OPEN				4.5	3.5	2.5	1.5	4.0	3.5	2.5	2.0	1.5	3.5	3.0	2.5	1.5	1.0
2800	MTR/SHEAVE		1.0	1.0	1.0	1.0	1.0	3.0	3.0	3.0	3.0	3.0	5.0	5.0	5.0	5.0		
	BHP			0.53	0.58	0.64	0.69	0.76	0.79	0.80	0.94	0.99	1.03	1.15	1.16	1.17	1.27	
	RPM			581	622	663	704	744	776	802	851	876	900	951	976	1001	1033	
	URNS OPEN			5.0	4.0	3.0	2.0	1.0	3.5	3.0	2.0	1.5	1.0	3.0	2.5	2.0	1.5	
3000	MTR/SHEAVE	1.0	1.0	1.0	1.0	1.0	3.0	3.0	3.0	3.0	3.0	5.0	5.0	5.0	5.0	5.0		
	BHP	0.59	0.66	0.73	0.80	0.87	0.90	0.92	1.07	1.08	1.10	1.30	1.33	1.35	1.40	1.44		
	RPM	580	621	662	702	743	775	801	848	873	898	949	973	997	1022	1046		
	URNS OPEN	5.0	4.0	3.0	2.0	1.0	3.5	3.0	2.0	1.5	1.0	3.0	2.5	2.0	1.5	1.0		
3200	MTR/SHEAVE	1.0	1.0	1.0	1.0	3.0	3.0	3.0	3.0	3.0	5.0	5.0	5.0	5.0	5.0			
	BHP	0.72	0.81	0.90	0.98	1.02	1.04	1.19	1.21	1.23	1.44	1.47	1.51	1.54	1.57			
	RPM	620	661	701	741	773	799	846	871	895	946	970	994	1019	1043			
	URNS OPEN	4.0	3.0	2.0	1.0	3.5	3.0	2.0	1.5	1.0	3.0	2.5	2.0	1.5	1.0			
3400	MTR/SHEAVE	1.0	1.0	1.0	3.0	3.0	3.0	3.0	3.0	5.0	5.0	5.0	5.0	5.0				
	BHP	0.87	0.98	1.08	1.12	1.16	1.31	1.34	1.36	1.58	1.62	1.65	1.69	1.73				
	RPM	660	700	740	772	797	844	869	893	944	968	992	1016	1040				
	URNS OPEN	3.0	2.0	1.0	3.5	3.0	2.0	1.5	1.0	3.0	2.5	2.0	1.5	1.0				

07/25/07

Bold Face Requires Larger 2 HP Motor

A=Std Static/Std Mtr;B=Low Static/Std. Mtr;C=High Static/Std. Mtr;D=Std Static/Large Mtr;E=High Static/Large Mtr

Units factory shipped with standard static sheave and drive at 2.5 turns open (2600 cfm @ 0.4 in. ESP). Other speeds require field selection.

ISO/AHRI rating point with standard static sheave and drive at 1.5 turns open (2600 cfm @ 0.5 in. ESP). Other speeds require field selection.

For applications requiring higher static pressures, contact your local representative.

Performance data does not include drive losses and is based on sea level conditions.

Do not operate in gray region. "na" = information not available at time of printing.

All airflow is rated at lowest Voltage if unit is dual Voltage rated, i.e. 208V for 208-230V units.

For wet coil performance first calculate the face velocity of the air coil (Face Velocity [fpm] = Airflow [cfm] / Face Area [sq ft]).

Then for velocities of 200 fpm reduce the static capability by 0.03 in. wg, 300 fpm by 0.08 in. wg, and 400 fpm by 0.12 in. wg.

Horizontal GX095 - Blower Performance Data

Belt Drive

Airflow in CFM with dry coil and clean air filter.

Rated CFM		External Static Pressure (in. w.g.)															
		0.0	0.1	0.2	0.3	0.4	0.5	0.6	0.7	0.8	0.9	1.0	1.2	1.4	1.6	1.8	2.0
2600	MTR/SHEAVE			2.0	2.0	2.0	2.0	1.0	1.0	1.0	1.0	1.0	4.0	4.0	4.0	4.0	5.0
	BHP			0.44	0.47	0.52	0.57	0.66	0.78	0.79	0.80	0.92	0.97	1.08	1.18	1.37	1.56
	RPM			584	625	667	708	757	806	831	856	905	960	1021	1082	1142	1202
	TURNS OPEN			5.0	4.0	3.0	2.0	4.0	3.0	2.5	2.0	1.0	3.0	2.0	1.0	0.0	3.0
2800	MTR/SHEAVE		2.0	2.0	2.0	2.0	1.0	1.0	1.0	1.0	1.0	4.0	4.0	4.0	4.0	5.0	5.0
	BHP		0.51	0.56	0.61	0.67	0.77	0.89	0.90	0.91	1.06	1.11	1.14	1.38	1.44	1.59	1.73
	RPM		583	625	665	707	756	804	829	854	902	933	982	1055	1100	1156	1212
	TURNS OPEN		5.0	4.0	3.0	2.0	4.0	3.0	2.5	2.0	1.0	3.5	2.5	1.5	0.5	3.5	2.5
3000	MTR/SHEAVE	2.0	2.0	2.0	2.0	1.0	1.0	1.0	1.0	1.0	4.0	4.0	4.0	4.0	4.0	5.0	5.0
	BHP	0.57	0.64	0.70	0.76	0.87	1.00	1.01	1.03	1.19	1.25	1.28	1.33	1.59	1.64	1.68	1.91
	RPM	582	624	665	705	754	802	827	852	900	930	955	1005	1078	1110	1169	1228
	TURNS OPEN	5.0	4.0	3.0	2.0	4.0	3.0	2.5	2.0	1.0	3.5	3.0	2.0	0.5	0.0	3.0	2.0
3200	MTR/SHEAVE	2.0	2.0	2.0	1.0	1.0	1.0	1.0	3.0	3.0	3.0	3.0	3.0	5.0	5.0		
	BHP	0.70	0.78	0.86	0.97	1.11	1.13	1.15	1.31	1.31	1.38	1.44	1.61	1.69	1.80	2.02	
	RPM	623	664	704	753	801	826	851	899	919	949	978	1036	1086	1137	1196	
	TURNS OPEN	4.0	3.0	2.0	4.0	3.0	2.5	2.0	1.0	4.0	3.5	3.0	2.5	1.5	3.5	2.5	
3400	MTR/SHEAVE	2.0	2.0	1.0	1.0	1.0	1.0	3.0	3.0	3.0	3.0	3.0	3.0	5.0	5.0		
	BHP	0.85	0.94	1.07	1.21	1.24	1.26	1.42	1.43	1.50	1.57	1.65	1.71	1.76	2.10	2.35	
	RPM	663	703	752	800	825	849	896	917	947	976	1020	1057	1094	1164	1223	
	TURNS OPEN	3.0	2.0	4.0	3.0	2.5	2.0	1.0	4.0	3.5	3.0	2.5	1.8	1.0	3.0	2.0	
3600	MTR/SHEAVE	2.0	1.0	1.0	1.0	1.0	3.0	3.0	3.0	3.0	3.0	3.0	5.0	5.0			
	BHP	1.01	1.16	1.31	1.34	1.37	1.54	1.55	1.63	1.70	1.78	1.87	2.06	2.15	2.40		
	RPM	702	751	798	823	848	894	915	945	974	1003	1031	1088	1133	1191		
	TURNS OPEN	2.0	4.0	3.0	2.5	2.0	1.0	4.0	3.5	3.0	2.5	2.0	1.5	3.5	2.5		
3800	MTR/SHEAVE	1.0	1.0	1.0	1.0	1.0	3.0	3.0	3.0	3.0	3.0	5.0	5.0				
	BHP	1.23	1.40	1.44	1.48	1.66	1.67	1.75	1.83	1.91	2.00	2.10	2.19	2.44			
	RPM	750	797	821	845	893	913	942	971	1000	1029	1086	1102	1160			
	TURNS OPEN	4.0	3.0	2.5	2.0	1.0	4.0	3.5	3.0	2.5	2.0	1.5	4.0	3.0			

07/25/07

Bold Face Requires Larger 2 HP Motor

A=Std Static/Std Mtr;B=Low Static/Std. Mtr;C=High Static/Std. Mtr;D=Std Static/Large Mtr;E=High Static/Large Mtr

Units factory shipped with standard static sheave and drive at 2 turns open (3200 cfm @ 0.6 in. ESP). Other speeds require field selection.

ISO/AHRI rating point with standard static sheave and drive at 2 turns open (3200 cfm @ 0.6 in. ESP). Other speeds require field selection.

For applications requiring higher static pressures, contact your local representative.

Performance data does not include drive losses and is based on sea level conditions.

Do not operate in gray region. "na" = information not available at time of printing.

All airflow is rated at lowest Voltage if unit is dual Voltage rated, i.e. 208V for 208-230V units.

For wet coil performance first calculate the face velocity of the air coil (Face Velocity [fpm] = Airflow [cfm] / Face Area [sq ft]).

Then for velocities of 200 fpm reduce the static capability by 0.03 in. wg, 300 fpm by 0.08 in. wg, and 400 fpm by 0.12in. wg.

Horizontal GX120 - Blower Performance Data

Belt Drive

Airflow in CFM with dry coil and clean air filter.

Rated CFM		External Static Pressure (in. w.g.)																				
		0.0	0.1	0.2	0.3	0.4	0.5	0.6	0.7	0.8	0.9	1.0	1.2	1.4	1.6	1.8	2.0					
3000	MTR/SHEAVE					2.0	2.0	2.0	2.0	1.0	1.0	1.0	1.0	1.0	1.0	3.0	3.0					
	BHP					0.80	0.88	0.96	1.07	1.09	1.11	1.13	1.28	1.36	1.48	1.67	1.86					
	RPM					707	748	789	830	857	882	907	931	956	1032	1115	1198					
	TURNS OPEN					5.0	4.0	3.0	2.0	2.0	5.0	4.5	4.0	3.5	2.5	1.0	4.5	3.5				
3200	MTR/SHEAVE					2.0	2.0	2.0	2.0	1.0	1.0	1.0	1.0	1.0	3.0	3.0	3.0					
	BHP					0.90	0.99	1.09	1.16	1.22	1.25	1.27	1.34	1.49	1.63	1.77	1.98	2.08				
	RPM					707	747	788	830	855	880	905	930	955	1031	1107	1166	1210				
	TURNS OPEN					5.0	4.0	3.0	2.0	2.0	5.0	4.5	4.0	3.5	2.5	1.0	4.0	3.0	2.5			
3400	MTR/SHEAVE					2.0	2.0	2.0	2.0	1.0	1.0	1.0	1.0	1.0	3.0	3.0	3.0	3.0				
	BHP					0.99	1.09	1.20	1.19	1.35	1.38	1.41	1.44	1.47	1.55	1.76	2.06	2.15	2.24			
	RPM					706	747	787	829	854	879	904	929	954	1004	1070	1137	1180	1224			
	TURNS OPEN					5.0	4.0	3.0	2.0	2.0	5.0	4.5	4.0	3.5	3.0	2.0	4.5	3.5	2.5	2.0		
3600	MTR/SHEAVE					2.0	2.0	2.0	2.0	1.0	1.0	1.0	1.0	1.0	3.0	3.0	3.0	3.0	3.0			
	BHP					1.05	1.18	1.30	1.32	1.47	1.51	1.54	1.58	1.61	1.85	1.90	2.12	2.22	2.32	2.51		
	RPM					706	746	787	828	853	878	903	928	953	1001	1044	1103	1134	1184	1233		
	TURNS OPEN					5.0	4.0	3.0	2.0	2.0	5.0	4.5	4.0	3.5	3.0	2.0	5.0	4.0	3.5	2.5	1.5	
3800	MTR/SHEAVE					2.0	2.0	2.0	2.0	1.0	1.0	1.0	1.0	1.0	3.0	3.0	3.0	3.0	3.0			
	BHP					1.11	1.25	1.39	1.53	1.59	1.63	1.67	1.71	1.75	1.99	2.08	2.16	2.27	2.37	2.64	2.75	
	RPM					705	756	786	827	853	878	902	927	951	999	1037	1075	1118	1161	1219	1255	
	TURNS OPEN					5.0	4.0	3.0	2.0	2.0	5.0	4.5	4.0	3.5	3.0	2.0	1.0	4.5	3.5	3.0	2.0	1.5
4000	MTR/SHEAVE					2.0	2.0	2.0	2.0	1.0	1.0	1.0	1.0	1.0	3.0	3.0	3.0	3.0	3.0	3.0		
	BHP					1.31	1.46	1.61	1.68	1.74	1.79	1.84	1.89	2.13	2.17	2.20	2.43	2.68	2.76	2.84	2.94	
	RPM					745	786	826	852	877	901	926	950	998	1023	1047	1100	1157	1188	1231	1275	
	TURNS OPEN					4.0	3.0	2.0	2.0	2.0	5.0	4.5	4.0	3.5	3.0	2.0	1.0	5.0	4.0	3.0	2.5	1.5
4200	MTR/SHEAVE					2.0	2.0	2.0	2.0	1.0	1.0	1.0	1.0	1.0	3.0	3.0	3.0	3.0	3.0	3.0		
	BHP					1.52	1.69	1.85	1.88	1.90	1.96	2.02	2.26	2.30	2.34	2.57	2.84	2.91	2.97	3.28		
	RPM					785	825	851	876	900	925	949	997	1018	1039	1098	1155	1184	1214	1270		
	TURNS OPEN					3.0	2.0	2.0	2.0	2.0	5.0	4.5	4.0	3.5	3.0	2.0	1.0	5.0	4.5	3.5	2.5	2.0

07/23/07

A=Std Static/Std Mtr;B=Low Static/Std. Mtr;C=High Static/Std. Mtr;D=Std Static/Large Mtr;E=High Static/Large Mtr

Units factory shipped with standard static sheave and drive at 3.0 turns open (3600 cfm @ 0.9 in. ESP). Other speeds require field selection.

ISO/AHRI rating point with standard static sheave and drive at 2.0 turns open (3600 cfm @ 1.0 in. ESP). Other speeds require field selection.

For applications requiring higher static pressures, contact your local representative.

Performance data does not include drive losses and is based on sea level conditions.

Do not operate in gray region. "na" = information not available at time of printing.

All airflow is rated at lowest Voltage if unit is dual Voltage rated, i.e. 208V for 208-230V units.

For wet coil performance first calculate the face velocity of the air coil (Face Velocity [fpm] = Airflow [cfm] / Face Area [sq ft]).

Then for velocities of 200 fpm reduce the static capability by 0.03 in. wg, 300 fpm by 0.08 in. wg, and 400 fpm by 0.12in. wg.

Vertical GX080 - Blower Performance Data

Belt Drive

Airflow in CFM with dry coil and clean air filter.

Rated CFM		External Static Pressure (in. w.g.)															
		0.0	0.1	0.2	0.3	0.4	0.5	0.6	0.7	0.8	0.9	1.0	1.1	1.2	1.3	1.4	1.5
2200	MTR/SHEAVE	2.0	2.0	2.0	2.0	1.0	1.0	1.0	1.0	1.0	1.0	1.0	5.0	5.0	5.0	5.0	5.0
	BHP	0.29	0.33	0.38	0.37	0.45	0.47	0.50	0.54	0.58	0.64	0.69	0.71	0.73	0.84	0.95	1.05
	RPM	437	478	518	539	586	617	647	677	707	736	765	775	809	843	876	909
	URNS OPEN	4.0	3.0	2.0	1.5	5.0	4.5	4.0	3.5	3.0	2.5	2.0	3.5	3.0	2.5	2.0	1.5
2400	MTR/SHEAVE	2.0	B 2.0	2.0	1.0	1.0	1.0	1.0	1.0	1.0	1.0	5.0	5.0	5.0	5.0	5.0	5.0
	BHP	0.38	0.44	0.43	0.52	0.56	0.59	0.63	0.68	0.73	0.78	0.81	0.83	0.94	1.05	1.13	1.20
	RPM	477	517	538	585	615	645	675	704	734	763	774	807	841	874	907	940
	URNS OPEN	3.0	2.0	1.5	5.0	4.5	4.0	3.5	3.0	2.5	2.0	3.5	3.0	2.5	2.0	1.5	1.0
2600	MTR/SHEAVE	2.0	2.0	1.0	1.0	1.0	1.0	1.0	1.0	1.0	5.0	5.0	5.0	5.0	5.0	5.0	
	BHP	0.49	0.50	0.59	0.63	0.67	0.72	0.77	0.83	0.89	0.91	0.94	1.05	1.17	1.24	1.32	
	RPM	516	537	584	614	643	673	702	732	761	772	806	839	871	905	938	
	URNS OPEN	2.0	1.5	5.0	4.5	4.0	A 3.5	3.0	2.5	2.0	3.5	3.0	2.5	2.0	1.5	1.0	
2800	MTR/SHEAVE	2.0	1.0	1.0	1.0	1.0	A 1.0	1.0	1.0	5.0	5.0	5.0	5.0	5.0	5.0		
	BHP	0.56	0.66	0.71	0.75	0.81	0.86	0.92	0.99	1.02	1.05	1.17	1.29	1.37	1.44		
	RPM	536	582	612	642	671	700	729	758	770	804	837	869	903	936		
	URNS OPEN	1.5	5.0	4.5	4.0	3.5	3.0	2.5	2.0	3.5	3.0	2.5	2.0	1.5	1.0		
3000	MTR/SHEAVE	1.0	1.0	1.0	1.0	1.0	1.0	1.0	5.0	5.0	5.0	F 5.0	5.0	5.0			
	BHP	0.72	0.78	0.83	0.89	0.95	1.02	1.09	1.12	1.16	1.29	1.41	1.49	1.57			
	RPM	581	611	640	669	698	727	756	768	802	835	867	900	933			
	URNS OPEN	5.0	4.5	4.0	3.5	3.0	2.5	2.0	3.5	3.0	2.5	2.0	1.5	1.0			
3200	MTR/SHEAVE	1.0	1.0	1.0	1.0	1.0	1.0	5.0	5.0	5.0	5.0	5.0	5.0				
	BHP	0.83	0.90	0.97	1.03	1.11	1.18	1.14	1.27	1.40	1.53	1.61	1.70				
	RPM	610	639	668	697	726	754	767	800	833	865	898	930				
	URNS OPEN	4.5	4.0	3.5	3.0	2.5	2.0	3.5	3.0	2.5	2.0	1.5	1.0				
3400	MTR/SHEAVE	1.0	1.0	1.0	1.0	5.0	5.0	5.0	5.0	5.0	5.0	5.0					
	BHP	0.97	1.04	1.11	1.19	1.23	1.30	1.37	1.51	1.64	1.73	1.82					
	RPM	637	666	695	725	731	765	798	830	862	895	927					
	URNS OPEN	4.0	3.5	3.0	2.5	4.0	3.5	3.0	2.5	2.0	1.5	1.0					

07/25/07

Bold Face Requires 1.5 HP Motor

A=Std Static/Std Mtr;B=Low Static/Std. Mtr;C=High Static/Std. Mtr;D=Std Static/Large Mtr;E=High Static/Large Mtr

Units factory shipped with standard static sheave and drive at 3 turns open (2600 cfm @ 0.6 in. ESP). Other speeds require field selection.

ISO/AHRI rating point with standard static sheave and drive at 3 turns open (2600 cfm @ 0.6 in. ESP). Other speeds require field selection.

For applications requiring higher static pressures, contact your local representative.

Performance data does not include drive losses and is based on sea level conditions.

Do not operate in gray region. "na" = information not available at time of printing.

All airflow is rated at lowest Voltage if unit is dual Voltage rated, i.e. 208V for 208-230V units.

For wet coil performance first calculate the face velocity of the air coil (Face Velocity [fpm] = Airflow [cfm] / Face Area [sq ft]).

Then for velocities of 200 fpm reduce the static capability by 0.03 in. wg, 300 fpm by 0.08 in. wg, and 400 fpm by 0.12in. wg.

Vertical GX095 - Blower Performance Data

Belt Drive

Airflow in CFM with dry coil and clean air filter.

Rated CFM		External Static Pressure (in. w.g.)															
		0.0	0.1	0.2	0.3	0.4	0.5	0.6	0.7	0.8	0.9	1.0	1.2	1.4	1.6	1.8	2.0
2600	MTR/SHEAVE				1.0	1.0	1.0	1.0	1.0	1.0	1.0	1.0	4.0	4.0			
	BHP				0.61	0.64	0.66	0.68	0.76	0.81	0.87	0.89	0.94	1.05			
	RPM				581	601	621	663	703	739	774	784	827	867			
	TURNS OPEN				5.0	4.5	4.0	3.0	2.0	1.5	1.0	0.0	2.0	1.0			
2800	MTR/SHEAVE			1.0	1.0	1.0	1.0	1.0	1.0	1.0	1.0	4.0	4.0	4.0			
	BHP			0.65	0.66	0.68	0.75	0.86	0.87	0.88	1.02	1.05	1.14	1.23			
	RPM			579	600	620	660	700	721	741	780	797	813	845	890	940	960
	TURNS OPEN			5.0	4.5	4.0	3.0	2.0	1.5	1.0	0.0	2.5	1.5	0.0			
3000	MTR/SHEAVE		1.0	1.0	1.0	1.0	1.0	1.0	1.0	1.0	3.0	3.0	3.0	3.0	3.0	5.0	5.0
	BHP		0.72	0.73	0.74	0.84	0.96	0.98	0.99	1.13	1.14	1.17	1.23	1.36	1.48	1.59	1.69
	RPM		578	599	620	659	699	719	739	778	795	819	843	890	937	942	967
	TURNS OPEN		5.0	4.5	4.0	3.0	2.0	1.5	1.0	0.0	3.0	2.5	2.0	1.0	0.0	3.0	2.5
3200	MTR/SHEAVE	1.0	1.0	1.0	1.0	1.0	1.0	1.0	1.0	3.0	3.0	3.0	3.0	3.0	5.0	5.0	5.0
	BHP	0.79	0.80	0.82	0.93	1.06	1.08	1.10	1.25	1.26	1.31	1.36	1.49	1.62	1.67	1.85	2.03
	RPM	578	599	619	659	699	719	739	778	795	819	843	890	937	942	967	991
	TURNS OPEN	5.0	4.5	4.0	3.0	2.0	1.5	1.0	0.0	3.0	2.5	2.0	1.0	0.0	3.0	2.5	2.0
3400	MTR/SHEAVE	1.0	1.0	1.0	1.0	1.0	1.0	1.0	3.0	3.0	3.0	3.0	3.0	5.0	5.0	5.0	5.0
	BHP	0.84	0.89	1.01	1.15	1.17	1.20	1.35	1.36	1.42	1.48	1.52	1.61	1.82	1.90	1.99	2.03
	RPM	597	619	658	697	718	738	776	794	818	841	857	888	940	963	986	1034
	TURNS OPEN	4.5	4.0	3.0	2.0	1.5	1.0	0.0	3.0	2.5	2.0	1.5	1.0	3.0	2.5	2.0	1.0
3600	MTR/SHEAVE	1.0	1.0	1.0	1.0	1.0	1.0	3.0	3.0	3.0	3.0	3.0	5.0	5.0	5.0	5.0	5.0
	BHP	0.97	1.09	1.23	1.26	1.29	1.45	1.47	1.53	1.60	1.67	1.74	1.95	2.05	2.14	2.19	2.41
	RPM	618	657	696	716	736	775	792	815	838	862	885	937	960	983	1031	1077
	TURNS OPEN	4.0	3.0	2.0	1.5	1.0	0.0	3.0	2.5	2.0	1.5	1.0	3.0	2.5	2.0	1.0	0.0
3800	MTR/SHEAVE	1.0	1.0	1.0	1.0	1.0	3.0	3.0	3.0	3.0	3.0	5.0	5.0	5.0	5.0	5.0	
	BHP	1.17	1.32	1.35	1.38	1.55	1.57	1.64	1.71	1.78	1.86	2.09	2.18	2.28	2.34	2.57	
	RPM	656	695	715	735	773	790	814	837	860	883	935	958	981	1029	1074	
	TURNS OPEN	3.0	2.0	1.5	1.0	0.0	3.0	2.5	2.0	1.5	1.0	3.0	2.5	2.0	1.0	0.0	

7/25/07

Bold Face Requires Larger 2 HP Motor

A=Std Static/Std Mtr;B=Low Static/Std. Mtr;C=High Static/Std. Mtr;D=Std Static/Large Mtr;E=High Static/Large Mtr

Units factory shipped with standard static sheave and drive at 2 turns open (2800 cfm @ 0.6 in. ESP). Other speeds require field selection.

ISO/AHRI rating point with standard static sheave and drive at 1 turns open (2800 cfm @ 0.7 in. ESP). Other speeds require field selection.

For applications requiring higher static pressures, contact your local representative.

Performance data does not include drive losses and is based on sea level conditions.

Do not operate in gray region. "na" = information not available at time of printing.

All airflow is rated at lowest Voltage if unit is dual Voltage rated, i.e. 208V for 208-230V units.

For wet coil performance first calculate the face velocity of the air coil (Face Velocity [fpm] = Airflow [cfm] / Face Area [sq ft]).

Then for velocities of 200 fpm reduce the static capability by 0.03 in. wg, 300 fpm by 0.08 in. wg, and 400 fpm by 0.12in. wg.

Vertical GX120 - Blower Performance Data

Belt Drive

Airflow in CFM with dry coil and clean air filter.

Rated CFM		External Static Pressure (in. w.g.)															
		0.0	0.1	0.2	0.3	0.4	0.5	0.6	0.7	0.8	0.9	1.0	1.2	1.4	1.6	1.8	2.0
3200	MTR/SHEAVE	2.0	2.0	2.0	2.0	2.0	1.0	1.0	1.0	1.0	1.0	1.0	1.0	3.0	3.0	3.0	
	BHP	0.50	0.51	0.59	0.68	0.68	0.79	0.92	0.92	0.92	1.08	1.16	1.30	1.31	1.41	1.59	
	RPM	418	438	480	521	541	582	623	644	665	705	732	787	826	867	932	
	TURNS OPEN	4.5	4.0	3.0	2.0	1.0	5.0	4.0	3.5	3.0	2.0	1.5	0.5	2.0	1.0	0.0	
3400	MTR/SHEAVE	2.0	2.0	2.0	2.0	1.0	1.0	1.0	1.0	1.0	1.0	1.0	3.0	3.0	3.0		
	BHP	0.58	0.67	0.77	0.78	0.90	1.04	1.05	1.07	1.16	1.26	1.28	1.37	1.47	1.65		
	RPM	438	480	520	541	582	622	643	664	694	724	746	795	843	888		
	TURNS OPEN	4.0	3.0	2.0	1.0	5.0	4.0	3.5	3.0	2.5	1.5	1.0	3.0	1.5	0.5		
3600	MTR/SHEAVE	2.0	2.0	2.0	1.0	1.0	1.0	1.0	1.0	1.0	1.0	3.0	3.0	3.0	3.0		
	BHP	0.74	0.86	0.88	1.00	1.02	1.17	1.20	1.22	1.24	1.44	1.47	1.52	1.82	1.90		
	RPM	479	519	540	581	602	643	663	684	704	745	765	806	866	906		
	TURNS OPEN	3.0	2.0	1.0	5.0	4.5	3.5	3.0	2.5	2.0	1.0	3.5	2.5	1.0	0.0		
3800	MTR/SHEAVE	2.0	2.0	1.0	1.0	1.0	1.0	1.0	1.0	1.0	3.0	3.0	3.0	3.0			
	BHP	0.94	0.96	1.10	1.15	1.24	1.32	1.35	1.38	1.41	1.62	1.66	1.91	2.06			
	RPM	519	539	581	622	642	662	683	704	723	764	784	823	884			
	TURNS OPEN	2.0	1.0	5.0	4.0	3.5	3.0	2.5	2.0	1.5	3.5	3.0	2.0	0.5			
4000	MTR/SHEAVE	2.0	1.0	1.0	1.0	1.0	1.0	1.0	1.0	1.0	3.0	3.0	3.0	3.0	5.0	5.0	5.0
	BHP	1.04	1.20	1.26	1.35	1.44	1.47	1.51	1.55	1.58	1.81	1.86	1.96	2.17	2.25	2.39	2.66
	RPM	539	580	621	641	661	682	703	724	744	783	803	843	893	933	970	1017
	TURNS OPEN	1.0	5.0	4.0	3.5	3.0	2.5	2.0	1.5	1.0	3.0	2.5	1.5	0.0	3.5	2.5	1.5
4200	MTR/SHEAVE	1.0	1.0	1.0	1.0	1.0	1.0	1.0	1.0	4.0	4.0	4.0	4.0	4.0	5.0	5.0	5.0
	BHP	1.28	1.36	1.45	1.54	1.59	1.63	1.67	1.72	1.95	2.01	2.06	2.19	2.31	2.48	2.75	3.03
	RPM	580	620	641	661	682	702	722	742	782	802	822	863	902	944	991	1037
	TURNS OPEN	5.0	4.0	3.5	3.0	2.5	2.0	1.5	1.0	3.0	2.5	2.0	1.0	0.0	3.0	2.0	1.0
4400	MTR/SHEAVE	1.0	1.0	1.0	1.0	1.0	1.0	1.0	4.0	4.0	4.0	4.0	4.0	5.0	5.0	5.0	
	BHP	1.46	1.55	1.65	1.70	1.75	1.80	1.85	2.09	2.15	2.21	2.28	2.41	2.54	2.80	3.08	
	RPM	620	640	660	681	701	722	742	781	801	821	841	881	919	965	1012	
	TURNS OPEN	4.0	3.5	3.0	2.5	2.0	1.5	1.0	3.0	2.5	2.0	1.5	0.5	3.5	2.5	1.5	

07/25/07

Bold Face Requires Larger 3 HP Motor

A=Std Static/Std Mtr;B=Low Static/Std. Mtr;C=High Static/Std. Mtr;D=Std Static/Large Mtr;E=High Static/Large Mtr

Units factory shipped with standard static sheave and drive at 3 turns open (3600 cfm @ 0.6 in. ESP). Other speeds require field selection.

ISO/AHRI rating point with standard static sheave and drive at 1 turns open (3600 cfm @ 0.9 in. ESP). Other speeds require field selection.

For applications requiring higher static pressures, contact your local representative.

Performance data does not include drive losses and is based on sea level conditions.

Do not operate in gray region. "na" = information not available at time of printing.

All airflow is rated at lowest Voltage if unit is dual Voltage rated, i.e. 208V for 208-230V units.

For wet coil performance first calculate the face velocity of the air coil (Face Velocity [fpm] = Airflow [cfm] / Face Area [sq ft]).

Then for velocities of 200 fpm reduce the static capability by 0.03 in. wg, 300 fpm by 0.08 in. wg, and 400 fpm by 0.12 in. wg.

Vertical GX160 - Blower Performance Data

Belt Drive

Airflow in CFM with dry coil and clean air filter.

Rated CFM		External Static Pressure (in. w.g.)															
		0.0	0.1	0.2	0.3	0.4	0.5	0.6	0.7	0.8	0.9	1.0	1.1	1.2	1.3	1.4	1.5
4400	MTR/SHEAVE	2.0	2.0	2.0	2.0	1.0	1.0	1.0	1.0	1.0	1.0	1.0	5.0	5.0	5.0	5.0	5.0
	BHP	0.29	0.33	0.38	0.37	0.45	0.47	0.50	0.54	0.58	0.64	0.69	0.71	0.73	0.84	0.95	1.05
	RPM	437	478	518	539	586	617	647	677	707	736	765	775	809	843	876	909
	URNS OPEN	4.0	3.0	2.0	1.5	5.0	4.5	4.0	3.5	3.0	2.5	2.0	3.5	3.0	2.5	2.0	1.5
4600	MTR/SHEAVE	2.0	2.0	2.0	2.0	1.0	1.0	1.0	1.0	1.0	1.0	1.0	5.0	5.0	5.0	5.0	5.0
	BHP	0.33	0.38	0.41	0.44	0.50	0.53	0.57	0.61	0.66	0.71	0.75	0.77	0.84	0.95	1.04	1.13
	RPM	457	498	528	562	601	631	661	691	720	750	770	791	825	858	892	925
	URNS OPEN	3.5	2.5	1.5	0.5	4.5	4.0	3.5	3.0	2.5	2.0	1.0	3.0	2.5	2.0	1.5	1.0
4800	MTR/SHEAVE	2.0	2.0	2.0	1.0	1.0	1.0	1.0	1.0	1.0	1.0	5.0	5.0	5.0	5.0	5.0	5.0
	BHP	0.38	0.44	0.43	0.52	0.56	0.59	0.63	0.68	0.73	0.78	0.81	0.83	0.94	1.05	1.13	1.20
	RPM	477	517	538	585	615	645	675	704	734	763	774	807	841	874	907	940
	URNS OPEN	3.0	2.0	1.5	5.0	4.5	4.0	3.5	3.0	2.5	2.0	3.5	3.0	2.5	2.0	1.5	1.0
5000	MTR/SHEAVE	2.0	2.0	2.0	1.0	1.0	1.0	1.0	1.0	1.0	1.0	5.0	5.0	5.0	5.0	5.0	5.0
	BHP	0.44	0.47	0.51	0.58	0.62	0.66	0.70	0.75	0.81	0.85	0.87	0.94	1.05	1.15	1.22	0.60
	RPM	497	527	561	599	629	659	688	718	747	768	790	823	856	889	923	470
	URNS OPEN	2.5	1.5	1.0	4.5	4.0	3.5	3.0	2.5	2.0	1.5	3.0	2.5	2.0	1.5	1.0	0.5
5200	MTR/SHEAVE	2.0	2.0	1.0	1.0	1.0	1.0	1.0	1.0	1.0	5.0	5.0	5.0	5.0	5.0	5.0	
	BHP	0.49	0.50	0.59	0.63	0.67	0.72	0.77	0.83	0.89	0.91	0.94	1.05	1.17	1.24	1.32	
	RPM	516	537	584	614	643	673	702	732	761	772	806	839	871	905	938	
	URNS OPEN	2.0	1.5	5.0	4.5	4.0	3.5	3.0	2.5	2.0	3.5	3.0	2.5	2.0	1.5	1.0	
5400	MTR/SHEAVE	2.0	2.0	1.0	1.0	1.0	1.0	1.0	1.0	1.0	5.0	5.0	5.0	5.0	5.0	5.0	
	BHP	0.53	0.58	0.65	0.69	0.74	0.79	0.85	0.91	0.95	0.98	1.05	1.17	1.27	1.34	0.66	
	RPM	526	560	598	628	657	686	716	745	766	788	821	854	887	920	469	
	URNS OPEN	1.5	1.0	4.5	4.0	3.5	3.0	2.5	2.0	1.5	3.0	2.5	2.0	1.5	1.0	0.5	
5600	MTR/SHEAVE	2.0	1.0	1.0	1.0	1.0	1.0	1.0	1.0	5.0	5.0	5.0	5.0	5.0	5.0		
	BHP	0.56	0.66	0.71	0.75	0.81	0.86	0.92	0.99	1.02	1.05	1.17	1.29	1.37	1.44		
	RPM	536	582	612	642	671	700	729	758	770	804	837	869	903	936		
	URNS OPEN	1.5	5.0	4.5	4.0	3.5	3.0	2.5	2.0	3.5	3.0	2.5	2.0	1.5	1.0		

7/25/07

Bold Face Requires Larger 1.5 HP Motor

A=Std Static/Std Mtr;B=Low Static/Std. Mtr;C=High Static/Std. Mtr;D=Std Static/Large Mtr;E=High Static/Large Mtr

Units factory shipped with standard static sheave and drive at 3 turns open (5000 cfm @ 0.6 in. ESP). Other speeds require field selection.

ISO/AHRI rating point with standard static sheave and drive at 2.0 turns open (5000 cfm @ 0.7 in. ESP). Other speeds require field selection.

For applications requiring higher static pressures, contact your local representative.

Performance data does not include drive losses and is based on sea level conditions.

Do not operate in gray region. "na" = information not available at time of printing.

All airflow is rated at lowest Voltage if unit is dual Voltage rated, i.e. 208V for 208-230V units.

For wet coil performance first calculate the face velocity of the air coil (Face Velocity [fpm] = Airflow [cfm] / Face Area [sq ft]).

Then for velocities of 200 fpm reduce the static capability by 0.03 in. wg, 300 fpm by 0.08 in. wg, and 400 fpm by 0.12 in. wg.

BHP is given for each blower. Multiply BHP x 2 for unit BHP.

Vertical GX180 - Blower Performance Data

Belt Drive

Airflow in CFM with dry coil and clean air filter.

Rated CFM		External Static Pressure (in. w.g.)															
		0.0	0.1	0.2	0.3	0.4	0.5	0.6	0.7	0.8	0.9	1.0	1.2	1.4	1.6	1.8	2.0
5200	MTR/SHEAVE				1.0	1.0	1.0	1.0	1.0	1.0	1.0	1.0	4.0	4.0			
	BHP				0.61	0.64	0.66	0.68	0.76	0.81	0.87	0.89	0.94	1.05			
	RPM				581	601	621	663	703	739	774	784	827	867			
	TURNS OPEN				5.0	4.5	4.0	3.0	2.0	1.5	1.0	0.5	2.0	1.0			
5400	MTR/SHEAVE				1.0	1.0	1.0	1.0	1.0	1.0	1.0	1.0	4.0	4.0			
	BHP				0.64	0.66	0.71	0.77	0.82	0.85	0.94	0.97	1.04	1.14			
	RPM				591	611	642	682	712	740	778	795	841	886			
	TURNS OPEN				4.5	4.0	3.5	2.5	1.5	1.0	0.5	0.0	1.5	0.5			
5600	MTR/SHEAVE			1.0	1.0	1.0	1.0	1.0	1.0	1.0	1.0	4.0	4.0	4.0			
	BHP			0.65	0.66	0.68	0.75	0.86	0.87	0.88	1.02	1.05	1.14	1.23			
	RPM			580	600	621	662	701	722	742	782	805	855	905			
	TURNS OPEN			5.0	4.5	4.0	3.0	2.0	1.5	1.0	0.0	2.5	1.5	0.0			
5800	MTR/SHEAVE			1.0	1.0	1.0	1.0	1.0	1.0	1.0	1.0	3.0	3.0	3.0	3.0	5.0	5.0
	BHP			0.69	0.70	0.76	0.86	0.92	0.93	1.01	1.08	1.11	1.19	1.30	0.74	0.80	0.85
	RPM			590	610	641	681	711	731	761	790	809	850	898	470	480	496
	TURNS OPEN			4.5	4.0	3.5	2.5	1.5	1.0	0.5	0.0	3.0	2.5	2.0	1.0	3.0	2.5
6000	MTR/SHEAVE		1.0	1.0	1.0	1.0	1.0	1.0	1.0	1.0	3.0	3.0	3.0	3.0	3.0	5.0	5.0
	BHP		0.72	0.73	0.74	0.84	0.96	0.98	0.99	1.13	1.14	1.17	1.23	1.36	1.48	1.59	1.69
	RPM		579	600	620	660	700	721	741	780	797	813	845	890	940	960	991
	TURNS OPEN		5.0	4.5	4.0	3.0	2.0	1.5	1.0	0.0	3.0	2.5	2.0	1.0	0.0	3.0	2.5
6200	MTR/SHEAVE		1.0	1.0	1.0	1.0	1.0	1.0	1.0	1.0	3.0	3.0	3.0	3.0	5.0	5.0	5.0
	BHP		0.76	0.77	0.84	0.95	1.02	1.04	1.12	1.20	1.23	1.27	1.36	1.49	1.58	1.72	1.86
	RPM		589	609	640	680	710	730	760	788	808	828	868	914	941	963	991
	TURNS OPEN		4.5	4.0	3.5	2.5	1.5	1.0	0.5	0.0	2.5	2.0	1.5	0.5	3.5	2.5	2.0
6400	MTR/SHEAVE	1.0	1.0	1.0	1.0	1.0	1.0	1.0	1.0	3.0	3.0	3.0	3.0	3.0	5.0	5.0	5.0
	BHP	0.79	0.80	0.82	0.93	1.06	1.08	1.10	1.25	1.26	1.31	1.36	1.49	1.62	1.67	1.85	2.03
	RPM	578	599	619	659	699	719	739	778	795	819	843	890	937	942	967	991
	TURNS OPEN	5.0	4.5	4.0	3.0	2.0	1.5	1.0	0.0	3.0	2.5	2.0	1.0	0.0	3.0	2.5	2.0

7/25/07

Bold Face Requires Larger 2.0 HP Motor

A=Std Static/Std Mtr;B=Low Static/Std. Mtr;C=High Static/Std. Mtr;D=Std Static/Large Mtr;E=High Static/Large Mtr

Units factory shipped with standard static sheave and drive at 3 turns open (5600 cfm @ 0.6 in. ESP). Other speeds require field selection.

ISO/AHRI rating point with standard static sheave and drive at 1.5 turns open (5600 cfm @ 0.7 in. ESP). Other speeds require field selection.

For applications requiring higher static pressures, contact your local representative.

Performance data does not include drive losses and is based on sea level conditions.

Do not operate in gray region. "na" = information not available at time of printing.

All airflow is rated at lowest Voltage if unit is dual Voltage rated, i.e. 208V for 208-230V units.

For wet coil performance first calculate the face velocity of the air coil (Face Velocity [fpm] = Airflow [cfm] / Face Area [sq ft]).

Then for velocities of 200 fpm reduce the static capability by 0.03 in. wg, 300 fpm by 0.08 in. wg, and 400 fpm by 0.12 in. wg.

BHP is given for each blower. Multiply BHP x 2 for unit BHP.

Vertical GX240 - Blower Performance Data

Belt Drive

Airflow in CFM with dry coil and clean air filter.

Rated CFM		External Static Pressure (in. w.g.)															
		0.0	0.1	0.2	0.3	0.4	0.5	0.6	0.7	0.8	0.9	1.0	1.2	1.4	1.6	1.8	2.0
6400	MTR/SHEAVE	2.0	2.0	2.0	2.0	2.0	1.0	1.0	1.0	1.0	1.0	1.0	1.0	3.0	3.0	3.0	
	BHP	0.50	0.51	0.59	0.68	0.68	0.79	0.92	0.92	0.92	1.08	1.16	1.30	1.31	1.41	1.59	
	RPM	418	438	480	521	541	582	623	644	665	705	732	787	826	867	932	
	TURNS OPEN	4.5	4.0	3.0	2.0	1.0	5.0	4.0	3.5	3.0	2.0	1.5	0.5	2.0	1.0	0.0	
6800	MTR/SHEAVE	2.0	2.0	2.0	2.0	1.0	1.0	1.0	1.0	1.0	1.0	1.0	3.0	3.0	3.0		
	BHP	0.58	0.67	0.77	0.78	0.90	1.04	1.05	1.07	1.16	1.26	1.28	1.37	1.47	1.65		
	RPM	438	480	520	541	582	622	643	664	694	724	746	795	843	888		
	TURNS OPEN	4.0	3.0	2.0	1.0	5.0	4.0	3.5	3.0	2.5	1.5	1.0	3.0	1.5	0.5		
7200	MTR/SHEAVE	2.0	2.0	2.0	1.0	1.0	1.0	1.0	1.0	1.0	1.0	3.0	3.0	3.0	3.0		
	BHP	0.74	0.86	0.88	1.00	1.02	1.17	1.20	1.22	1.24	1.44	1.47	1.52	1.82	1.90		
	RPM	479	519	540	581	602	643	663	684	704	745	765	806	866	906		
	TURNS OPEN	3.0	2.0	1.0	5.0	4.5	3.5	3.0	2.5	2.0	1.0	3.5	2.5	1.0	0.0		
7600	MTR/SHEAVE	2.0	2.0	1.0	1.0	1.0	1.0	1.0	1.0	1.0	3.0	3.0	3.0	3.0			
	BHP	0.94	0.96	1.10	1.15	1.24	1.32	1.35	1.38	1.41	1.62	1.66	1.91	2.06			
	RPM	519	539	581	622	642	662	683	704	723	764	784	823	884			
	TURNS OPEN	2.0	1.0	5.0	4.0	3.5	3.0	2.5	2.0	1.5	3.5	3.0	2.0	0.5			
8000	MTR/SHEAVE	2.0	1.0	1.0	1.0	1.0	1.0	1.0	1.0	3.0	3.0	3.0	3.0	5.0	5.0	5.0	
	BHP	1.04	1.20	1.26	1.35	1.44	1.47	1.51	1.55	1.58	1.81	1.86	1.96	2.17	2.25	2.39	2.66
	RPM	539	580	621	641	661	682	703	724	744	783	803	843	893	933	970	1017
	TURNS OPEN	1.0	5.0	4.0	3.5	3.0	2.5	2.0	1.5	1.0	3.0	2.5	1.5	0.0	3.5	2.5	1.5
8400	MTR/SHEAVE	1.0	1.0	1.0	1.0	1.0	1.0	1.0	1.0	4.0	4.0	4.0	4.0	4.0	5.0	5.0	5.0
	BHP	1.28	1.36	1.45	1.54	1.59	1.63	1.67	1.72	1.95	2.01	2.06	2.19	2.31	2.48	2.75	3.03
	RPM	580	620	641	661	682	702	722	742	782	802	822	863	902	944	991	1037
	TURNS OPEN	5.0	4.0	3.5	3.0	2.5	2.0	1.5	1.0	3.0	2.5	2.0	1.0	0.0	3.0	2.0	1.0
8800	MTR/SHEAVE	1.0	1.0	1.0	1.0	1.0	1.0	1.0	1.0	4.0	4.0	4.0	4.0	5.0	5.0	5.0	
	BHP	1.46	1.55	1.65	1.70	1.75	1.80	1.85	2.09	2.15	2.21	2.28	2.41	2.54	2.80	3.08	
	RPM	620	640	660	681	701	722	742	781	801	821	841	881	919	965	1012	
	TURNS OPEN	4.0	3.5	3.0	2.5	2.0	1.5	1.0	3.0	2.5	2.0	1.5	0.5	3.5	2.5	1.5	

7/25/07

Bold Face Requires Larger 3.0 HP Motor

A=Std Static/Std Mtr;B=Low Static/Std. Mtr;C=High Static/Std. Mtr;D=Std Static/Large Mtr;E=High Static/Large Mtr

Units factory shipped with standard static sheave and drive at 2.5 turns open (7600 cfm @ 0.6 in. ESP). Other speeds require field selection.

ISO/AHRI rating point with standard static sheave and drive at 2 turns open (7600 cfm @ 0.7 in. ESP). Other speeds require field selection.

For applications requiring higher static pressures, contact your local representative.

Performance data does not include drive losses and is based on sea level conditions.

Do not operate in gray region. "na" = information not available at time of printing.

All airflow is rated at lowest Voltage if unit is dual Voltage rated, i.e. 208V for 208-230V units.

For wet coil performance first calculate the face velocity of the air coil (Face Velocity [fpm] = Airflow [cfm] / Face Area [sq ft]).

Then for velocities of 200 fpm reduce the static capability by 0.03 in. wg, 300 fpm by 0.08 in. wg, and 400 fpm by 0.12 in. wg.

BHP is given for each blower. Multiply BHP x 2 for unit BHP.

Vertical GX300 - Blower Performance Data

Belt Drive

Airflow in CFM with dry coil and clean air filter.

Rated CFM		External Static Pressure (in. w.g.)															
		0.0	0.1	0.2	0.3	0.4	0.5	0.6	0.7	0.8	0.9	1.0	1.2	1.4	1.6	1.8	2.0
8400	MTR/SHEAVE				2.0	2.0	2.0	2.0	2.0	1.0	1.0	1.0	1.0	1.0	1.0	3.0	
	BHP				1.46	1.49	1.77	1.94	2.11	2.29	2.32	2.39	2.65	2.72	2.80	2.36	
	RPM				677	696	745	778	810	841	858	878	912	932	951	994	
	TURNS OPEN				5.0	4.0	3.0	2.0	1.0	4.0	3.5	3.0	2.0	1.5	1.0	4.5	
8800	MTR/SHEAVE			2.0	2.0	2.0	2.0	2.0	1.0	1.0	1.0	1.0	1.0	3.0	3.0		
	BHP			1.55	1.70	1.86	2.03	2.21	2.39	2.42	2.50	2.75	2.83	2.91	2.63	2.61	
	RPM			674	708	742	774	806	837	853	873	907	926	945	981	1010	
	TURNS OPEN			5.0	4.0	3.0	2.0	1.0	4.0	3.5	3.0	2.0	1.5	1.0	4.5	4.0	
9200	MTR/SHEAVE		2.0	2.0	2.0	2.0	2.0	1.0	1.0	1.0	1.0	1.0	3.0	3.0	3.0		
	BHP		1.63	1.79	1.96	2.13	2.31	2.49	2.52	2.60	2.85	2.93	3.01	2.87	2.87	2.86	
	RPM		671	705	738	771	802	833	849	869	903	922	940	969	997	1025	
	TURNS OPEN		5.0	4.0	3.0	2.0	1.0	4.0	3.5	3.0	2.0	1.5	1.0	4.5	4.0	3.5	
9600	MTR/SHEAVE	2.0	2.0	2.0	2.0	2.0	1.0	1.0	1.0	1.0	1.0	3.0	3.0	3.0			
	BHP	1.72	1.88	2.04	2.22	2.40	2.58	2.62	2.70	2.95	3.03	3.11	3.09	3.10	3.11		
	RPM	668	702	735	767	799	829	845	864	898	917	935	959	985	1012		
	TURNS OPEN	5.0	4.0	3.0	2.0	1.0	4.0	3.5	3.0	2.0	1.5	1.0	4.5	4.0	3.5		
10000	MTR/SHEAVE	2.0	2.0	2.0	2.0	1.0	1.0	1.0	1.0	1.0	1.0	3.0	3.0	3.0			
	BHP	1.96	2.13	2.31	2.49	2.68	2.71	2.79	3.05	3.13	3.21	3.29	3.31	3.33			
	RPM	699	732	764	795	825	841	860	894	912	931	949	975	1001			
	TURNS OPEN	4.0	3.0	2.0	1.0	4.0	3.5	3.0	2.0	1.5	1.0	4.5	4.0	3.5			
10400	MTR/SHEAVE	2.0	2.0	2.0	1.0	1.0	1.0	1.0	1.0	1.0	3.0	3.0	3.0	3.0			
	BHP	2.21	2.39	2.58	2.77	2.81	2.89	3.13	3.22	3.31	3.39	3.51	3.54	3.56			
	RPM	729	761	792	821	837	856	890	908	926	944	965	990	1016			
	TURNS OPEN	3.0	2.0	1.0	4.0	3.5	3.0	2.0	1.5	1.0	4.5	4.0	3.5	3.0			
10800	MTR/SHEAVE	2.0	2.0	1.0	1.0	1.0	1.0	1.0	1.0	3.0	3.0	3.0	3.0				
	BHP	2.48	2.66	2.85	2.90	2.98	3.23	3.32	3.40	3.48	3.61	3.73	3.76				
	RPM	758	788	818	833	852	885	904	922	939	960	980	1005				
	TURNS OPEN	2.0	1.0	4.0	3.5	3.0	2.0	1.5	1.0	4.5	4.0	3.5	3.0				

7/25/07

A=Std Static/Std Mtr;B=Low Static/Std. Mtr;C=High Static/Std. Mtr;D=Std Static/Large Mtr;E=High Static/Large Mtr

Units factory shipped with standard static sheave and drive at 3.0 turns open (9500 cfm @ 0.7 in. ESP). Other speeds require field selection.

ISO/AHRI rating point with standard static sheave and drive at 3.0 turns open (9500 cfm @ 0.7 in. ESP). Other speeds require field selection.

For applications requiring higher static pressures, contact your local representative.

Performance data does not include drive losses and is based on sea level conditions.

Do not operate in gray region. "na" = information not available at time of printing.

All airflow is rated at lowest Voltage if unit is dual Voltage rated, i.e. 208V for 208-230V units.

For wet coil performance first calculate the face velocity of the air coil (Face Velocity [fpm] = Airflow [cfm] / Face Area [sq ft]).

Then for velocities of 200 fpm reduce the static capability by 0.03 in. wg, 300 fpm by 0.08 in. wg, and 400 fpm by 0.12 in. wg.

BHP is given for each blower. Multiply BHP x 2 for unit BHP.

Wiring Schematic - Dual Compressor with Aurora 460/-575/60/3

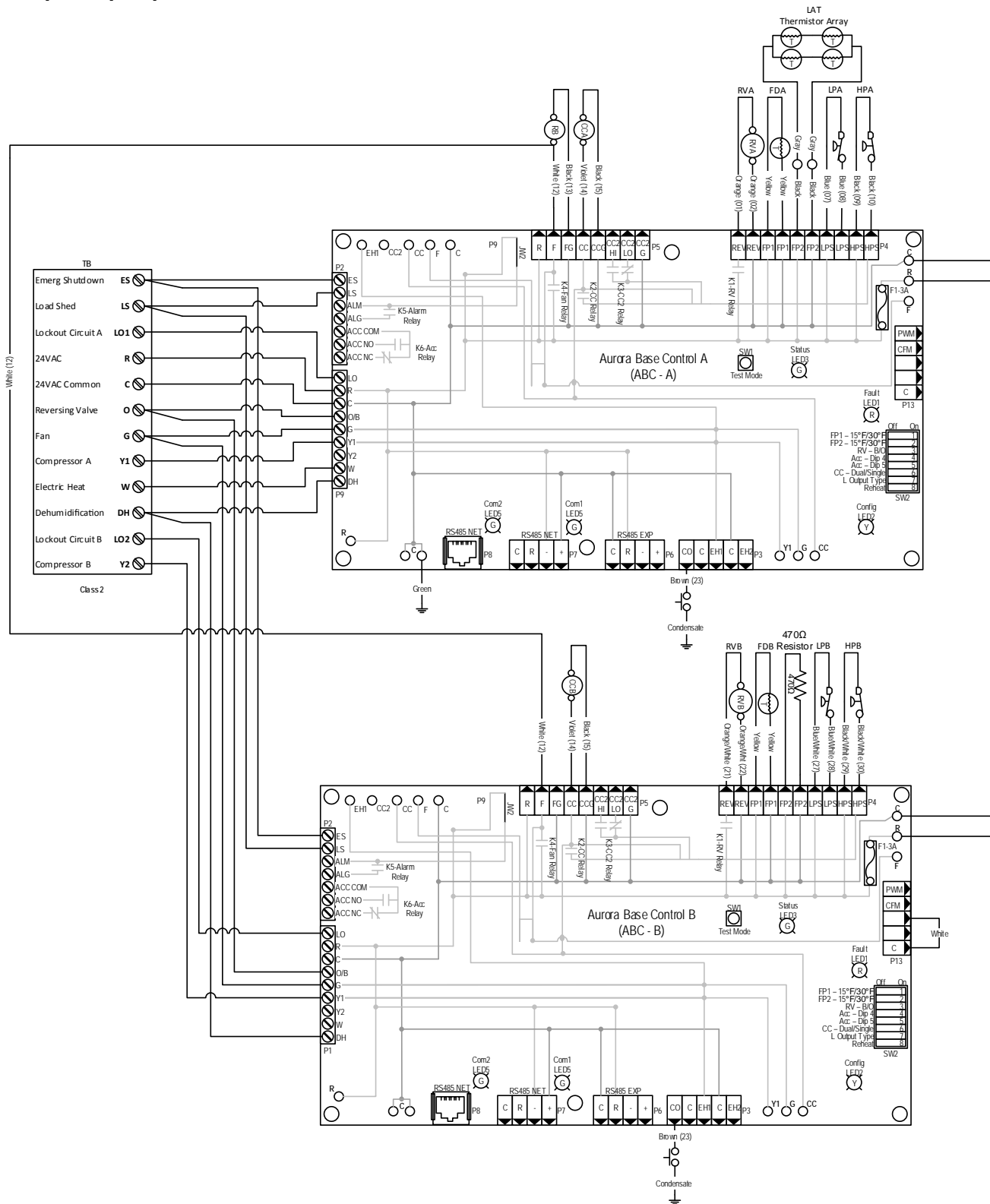

Wiring Schematic - Dual Compressor with Aurora

460-575/60/3

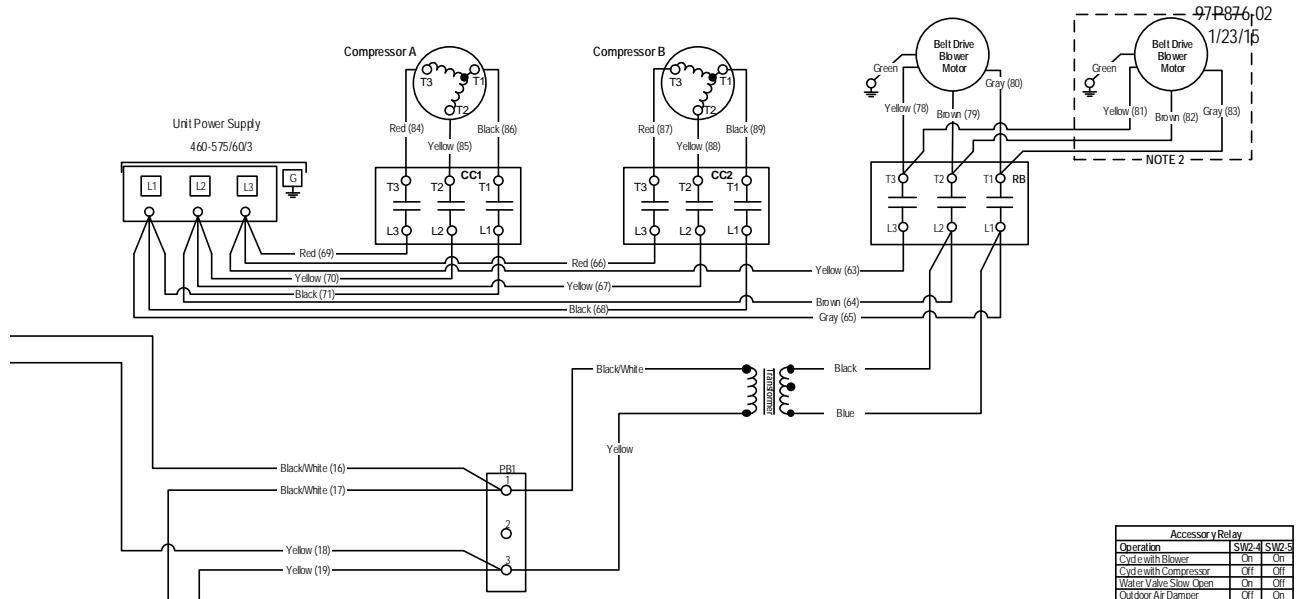

Accessory Relay		
Operation	SW2-4	SW2-5
Cycle with Blower	On	On
Cycle with Compressor	Off	Off
Water Valve Slow Open	On	Off
Outdoor Air Damper	Off	On

Aurora Timing Events		
Event	Normal Mode	Test Mode
Random Start Delay	5 to 80 seconds	1 second
Compressor On Delay	5 seconds	< 1 second
Compressor Minimum On Time	2 minutes	5 seconds
Compressor Short Cycle Delay	4 minutes	15 seconds
Blower Off Delay	30 seconds	2 seconds
Fault Recognition Delay - High Pressure	Less than 1 second	Less than 1 second
Start-Up Bypass - Low Pressure	2 minutes	30 seconds
Fault Recognition Delay - Low Pressure	30 seconds	30 seconds
Start-Up Bypass - Low Water/Air Coil Limit	2 minutes	30 seconds
Fault Recognition Delay - Low Water/Air Coil Limit	30 seconds	30 seconds
Fault Recognition Delay - Condensate Overflow	30 seconds	30 seconds
Thermostat Call Recognition Time	2 seconds	2 seconds
Auxiliary Heat Staging Delay	5 minutes	20 seconds
Emergency Heat Staging Delay	2 minutes	7.5 seconds
Water Valve Slow Open Delay	90 seconds	7.5 seconds
Reheat Delay	30 seconds	30 seconds

Aurora LED Flash Codes			
Slow Flash	1 second on and 1 second off		
Fast Flash	100 milliseconds on and 100 milliseconds off		
Flash Code	100 milliseconds on and 400 milliseconds off with a 2 second pause before repeating		
Random Start Delay			
Status LED (LED1, Green)	Fast Flash		
Configuration LED (LED2, Yellow)	Fast Flash		
Fault LED (LED3, Red)	Fast Flash		
Status LED (LED1, Green)			
Normal Mode	ON	No Software Override	Flash ECM Setting
Control is Non-Functional	OFF	DIP Switch Override	Slow Flash
Test Mode	Slow Flash	ECM Configure Mode	Fast Flash
Lockout Active	Fast Flash	Reset Configure Mode	Off
Configuration LED (LED2, Yellow)			
Dehumidification Mode	Flash Code 2	Low Air Coil Limit Lockout - FP2	Flash Code 4
Reserved	Flash Code 3	Low Water Coil Limit Lockout - FP1	Flash Code 5
Reserved	Flash Code 4	Reserved	Flash Code 6
Load Shed	Flash Code 5	Condensate Overflow Lockout	Flash Code 7
ESD	Flash Code 6	Over/Under Voltage Shutdown	Flash Code 8
Reserved	Flash Code 7	Reserved	Flash Code 9
		Reserved	Flash Code 10
		Air/Water Coil Limit Sensor Error	Flash Code 11

Legend

	Factory Low Voltage Wiring		Thermistor
	Factory Line Voltage Wiring		Relay Coil
	Field Line Voltage Wiring		Switch - Condensate Overflow
	Optional Black		Switch - High pressure
	DC Voltage/PCB Traces		Switch - Low pressure
	Field Zone Sensor Wiring		Polarized connector
	Internal Junction		Light Emitting Diode - Green
	Quick Connect Terminal		Light Emitting Diode - Yellow
	Field Wiring Lug		Light Emitting Diode - Red
	Ground		
	Relay Contacts - N.O., N.C.		
	Capacitor		
	Fuse		

CCA - Compressor Contactor A
 CCB - Compressor Contactor B
 CO - Condensate Overflow Sensor
 ES - Emergency Shutdown
 HPA - High Pressure Switch A
 HPB - High Pressure Switch B
 LPA - Low Pressure Switch A
 LPB - Low Pressure Switch B
 FDA - Freeze Detection Sensor A
 FDB - Freeze Detection Sensor B
 F1 - Fuse

SW1 - Push button
 SW2 - DIP package 8 position
 RVA - Reversing Valve Coil A
 RVB - Reversing Valve Coil B
 PGM - Phase Guard Monitor
 RH - Reheat Valve Coil

Notes:

1 - Only on units equipped with two fan motors.

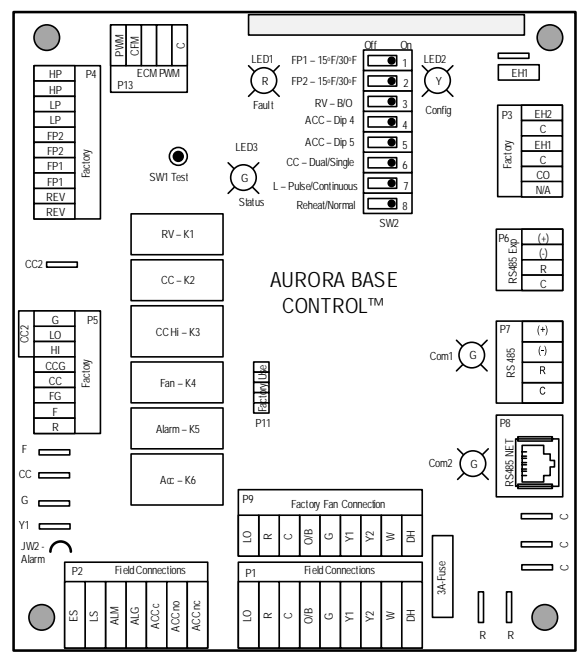

Controls - Aurora Base Control

Aurora 'Base' Control

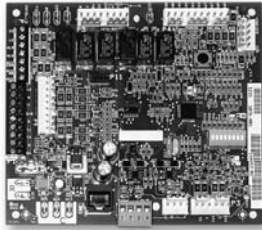

NOTE: Refer to the Aurora Base Control Application and Troubleshooting Guide and the Instruction Guide: Aurora Interface and Diagnostics (AID) Tool for additional information.

Control Features

Software ABC Standard Version 2.0

Single or Dual Capacity Compressors

Either single or dual capacity compressors can be operated.

Variable Speed ECM

Blower Motor Option (If Applicable)

A Variable Speed ECM blower motor can be driven directly using the onboard PWM output. Four blower speeds are available based upon the G, Y1, Y2, and W input signals to the board. The blower speeds can be changed either by the ECM manual configurations mode method or by using the Aurora AID Tool directly. All four blower speeds can be set to the same speed if desired.

5-Speed ECM Blower Motor Option (If Applicable)

A 5-Speed ECM blower motor will be driven directly using the thermostat connections. Any of the G, Y1, or Y2/W signals can drive any of the 5 available pre-programmed blower speeds on the motor. All 5 Series "G" vintage units will be wired this way at the factory.

Other Control Features

- Random start at power up
- Anti-short cycle protection
- High and low pressure cutouts
- Loss of charge
- Water coil freeze detection
- Air coil freeze detection
- Over/under voltage protection
- Condensate overflow sensor
- Load shed
- Dehumidification (where applicable)
- Emergency shutdown
- Hot gas reheat operation (where applicable)
- Diagnostic LED
- Test mode push button switch
- Two auxiliary electric heat outputs
- Alarm output
- Accessory output with N.O. and N.C.
- Modbus communication (master)
- Modbus communication (slave)

Field Selectable Options via Hardware

DIP Switch (SW1) – Test/Configuration Button (See SW1 Operation Table)

Test Mode

The control is placed in the test mode by holding the push button switch SW1 for 2 - 5 seconds. In test mode most of the control timings will be shortened by a factor of sixteen (16). LED3 (green) will flash at 1 second on and 1 second off. Additionally, when entering test mode LED1 (red) will flash the last lockout one time. Test mode will automatically time out after 30 minutes. Test mode can be exited by pressing and holding the SW1 button for 2 to 5 seconds or by cycling the power. **NOTE:** Test mode will automatically be exited after 30 minutes.

ECM Configuration Mode (If Applicable)

The control is placed in the ECM configuration mode by holding the pushbutton switch SW1 for 5 to 10 seconds, the high, low, and "G" ECM speeds can be selected by following the LED display lights. LED2 (yellow) will fast flash when entering the ECM configuration. When setting "G" speed LED3 (green) will be continuously lit, for low speed LED1 (red) will be continuously lit, and for high speed both LED3 (green) and LED1 (red) will be continuously lit. During the ECM configuration mode LED2 (yellow) will flash each of the 12 possible blower speeds 3 times. When the desired speed is flashed press SW1, LED2 will fast flash until SW1 is released. "G" speed has now been selected. Next select low speed, and high speed blower selections following the same process above. After third selection has been made, the control will exit the ECM configuration mode. Aux fan speed will remain at default or current setting and requires the AID Tool for adjustment.

Reset Configuration Mode

The control is placed in reset configuration mode by holding the push button switch SW1 for 50 to 60 seconds. This will reset all configuration settings and the EEPROM back to the factory default settings. LED3 (green) will turn off when entering reset configuration mode. Once LED3 (green) turns off, release SW1 and the control will reset.

DIP Switch (SW2)

SW2-1 FP1 Selection – Low water coil temperature limit setting for freeze detection. On = 30°F; Off = 15°F.

SW2-2 FP2 Selection – On = 30°F; Off = N/A

SW2-3 RV – O/B - thermostat type. Heat pump thermostats with "O" output in cooling or "B" output in Heating can be selected. On = O; Off = B.

SW2-4 and 2-5 Access Relay Operation (P2)

Access Relay Operation	SW2-4	SW2-5
Cycle with Blower	ON	ON
Cycle with Compressor	OFF	OFF
Water Valve Slow Opening	ON	OFF
Cycle with Comm. T-stat Hum Cmd	OFF	ON

Controls - Aurora Base Control cont.

Cycle with Blower - The accessory relay will cycle with the blower output.

Cycle with Compressor - The accessory relay will cycle with the compressor output.

Water Valve Slow Opening - The accessory relay will cycle and delay both the blower and compressor output for 90 seconds.

- SW2-6** CC Operation – selection of single or dual capacity compressor. On = Single Stage; Off = Dual Capacity
- SW2-7** Lockout and Alarm Outputs (P2) – selection of a continuous or pulsed output for both the LO and ALM Outputs. On = Continuous; Off = Pulsed
- SW2-8** Future Use

Alarm Jumper Clip Selection

From the factory, ALM is connected to 24 VAC via JW2. By cutting JW2, ALM becomes a dry contact connected to ALG.

ECM Blower Speeds

The blower speeds can be changed either by using the ECM manual configurations mode method or by using the Aurora AID Tool directly (see Instruction Guide: Aurora Interface and Diagnostics (AID) Tool topic).

Field Selectable Options via Software

(Selectable via the Aurora AID Tool)

ECM Blower Speeds

An ECM blower motor can be driven directly using the onboard PWM output. Four blower speeds are available, based upon the “G”, Y1 (low), Y2 (high), and Aux input signals to the board. The blower speeds can be changed either by the ECM manual configurations mode method (see ECM Configuration Mode topic) or by using the Aurora AID Tool directly. All four blower speeds can be set to the same speed if desired. Aux blower speed will remain at default or current setting and requires the AID Tool for adjustment.

Safety Features

The following safety features are provided to protect the compressor, heat exchangers, wiring and other components from damage caused by operation outside of design conditions.

Fuse – a 3 amp automotive type plug-in fuse provides protection against short circuit or overload conditions.

Anti-Short Cycle Protection – 4 minute anti-short cycle protection for the compressor.

Random Start – 5 to 80 second random start upon power up.

Fault Retry – in the fault condition, the control will stage off the outputs and then “try again” to satisfy the thermostat Y input call. Once the thermostat input calls are satisfied, the control will continue on as if no fault occurred. If 3 consecutive faults occur without satisfying the thermostat Y input call, then the control will go to Lockout mode.

Lockout – when locked out, the blower will operate continuously in “G” speed, and PSC blower motor output will remain on. The Alarm

output (ALM) and Lockout output (L) will be turned on. The fault type identification display LED1 (Red) shall flash the fault code. To reset lockout conditions with SW2-8 On, thermostat inputs “Y1”, “Y2”, and “W” must be removed for at least 3 seconds. To reset lockout conditions with SW2-8 Off, thermostat inputs “Y1”, “Y2”, “W”, and “DH” must be removed for at least 3 seconds. Lockout may also be reset by turning power off for at least 30 seconds or by enabling the emergency shutdown input for at least 3 seconds.

Lockout With Emergency Heat - if the control is locked out in the heating mode, and a Y2 or W input is received, the control will operate in the emergency heat mode while the compressor is locked out. The first emergency heat output will be energized 10 seconds after the W input is received, and the blower will shift to high speed. If the control remains locked out, and the W input is present, additional stage of emergency heat will stage on after 2 minutes. When the W input is removed, all of the emergency heat outputs will turn off, and the ECM blower will shift to “G” speed and PSC blower motor output will remain on.

High Pressure – fault is recognized when the Normally Closed High Pressure Switch, P4-9/10 opens, no matter how momentarily. The High Pressure Switch is electrically in series with the Compressor Contactor and serves as a hard-wired limit switch if an overpressure condition should occur.

Low Pressure - fault is recognized when the Normally Closed Low Pressure Switch, P4-7/8 is continuously open for 30 seconds. Closure of the LPS any time during the 30 second recognition time restarts the 30 second continuous open requirement. A continuously open LPS shall not be recognized during the 2 minute startup bypass time.

Loss of Charge – fault is recognized when the Normally Closed Low Pressure Switch, P4-7/8 is open prior to the compressor starting.

Condensate Overflow - fault is recognized when the impedance between this line and 24 VAC common or chassis ground drops below 100K ohms for 30 seconds continuously.

Freeze Detection (Coax) - set points shall be either 30°F or 15°F. When the thermistor temperature drops below the selected set point, the control shall begin counting down the 30 seconds delay. If the thermistor value rises above the selected set point, then the count should reset. The resistance value must remain below the selected set point for the entire length of the appropriate delay to be recognized as a fault. This fault will be ignored for the initial 2 minutes of the compressor run time.

Freeze Detection (Air Coil) - uses the FP2 input to protect against ice formation on the air coil. The FP2 input will operate exactly like FP1 except that the set point is 30 degrees and is not field adjustable.

Controls - Aurora Base Control cont.

Over/Under Voltage Shutdown - An over/under voltage condition exists when the control voltage is outside the range of 18 VAC to 30 VAC. If the over/under voltage shutdown lasts for 15 minutes, the lockout and alarm relay will be energized. Over/under voltage shutdown is self-resetting in that if the voltage comes back within range of 18 VAC to 30 VAC for at least 0.5 seconds, then normal operation is restored.

Operation Description

Power Up - The unit will not operate until all the inputs and safety controls are checked for normal conditions. The unit has a 5 to 80 second random start delay at power up. Then the compressor has a 4 minute anti-short cycle delay after the random start delay.

Standby In standby mode, Y1, Y2, W, DH, and G are not active. Input O may be active. The blower and compressor will be off.

Heating Operation

Single Compressor Heating, 2nd Stage (Y1, Y2)

The compressor will be staged to full capacity 20 seconds after Y2 input is received. The ECM blower will shift to high speed seconds after the Y2 input is received.

Dual Compressor Heating, 2nd Stage (Y1, Y2)

In dual compressor operation, two ABC boards used in 24 VAC operation, there will be a Y2 call to the Y1 input on the second ABC. The compressor will stage to full capacity 30 seconds after Y1 input is received to the second board.

Single Compressor Heating, 3rd Stage (Y1, Y2, W)

The hot water pump is de-energized and the first stage of electric heat is energized 10 seconds after the W command is received. If the demand continues the second stage of electric heat will be energized after 5 minutes.

Dual Compressor Heating, 3rd Stage (Y1, Y2, W)

The first stage of electric heat is energized 10 seconds after the W command is received. If the demand continues the second stage of electric heat will be energized after 5 minutes

Emergency Heat (W) - The blower will be started on "G" speed, 10 seconds later the first stage of electric heat will be turned on. 5 seconds after the first stage of electric heat is energized the blower will shift to Aux speed. If the emergency heat demand is not satisfied after 2 minutes the second electric heat stage will be energized.

Blower (G) - The blower will start immediately upon receiving a thermostat G command. If there are no other commands from the thermostat the ECM will run on "G" speed until the G command is removed. Regardless of blower input (G) from the thermostat, the blower will remain on for 30 seconds at the end of each heating cycle.

Cooling Operation

In all cooling operations, the reversing valve directly tracks the O input. Thus, anytime the O input is present, the reversing valve will be energized.

Single Compressor Cooling, 2nd Stage (Y1, Y2, O)

The compressor will be staged to full capacity 20 seconds after Y2 input was received. The ECM blower will shift to high speed 15 seconds after the Y2 input was received.

Dual Compressor Cooling, 2nd Stage (Y1, Y2, O)

In dual compressor operation, two ABC boards used in 24 VAC operation, there will be a Y2 call to the Y1 input on the second ABC. The compressor will stage to full capacity 30 seconds after Y1 input is received to the second board.

Blower (G) - The blower will start immediately upon receiving a thermostat G command. If there are no other commands from the thermostat the ECM will run on "G" speed until the G command is removed. Regardless of blower input (G) from the thermostat, the blower will remain on for 30 seconds at the end of each heating, cooling, and emergency heat cycle.

Dehumidification (Y1, O, DH or Y1, Y2, O, DH) - When a DH command is received from the thermostat during a compressor call for cooling the ECM blower speed will be reduced by 15% to increase dehumidification.

Emergency Shutdown - Four (4) seconds after a valid ES input, P2-7 is present, all control outputs will be turned off and remain off until the emergency shutdown input is no longer present. The first time that the compressor is started after the control exits the emergency shutdown mode, there will be an anti-short cycle delay followed by a random start delay. Input must be tied to common to activate.

Continuous Blower Operation - The blower output will be energized any time the control has a G input present, unless the control has an emergency shutdown input present. The blower output will be turned off when G input is removed.

Load Shed - The LS input disables all outputs with the exception of the blower output. When the LS input has been cleared, the anti-short cycle timer and random start timer will be initiated. Input must be tied to common to activate.

Controls - Aurora Base Control cont.

Aurora 'Base' Control LED Displays

These three LEDs display the status, configuration, and fault codes for the control. These can also be read in plain English via the Aurora AID Tool.

Status LED (LED3, Green)

Description of Operation	Fault LED, Green
Normal Mode	ON
Control is Non-functional	OFF
Test Mode	Slow Flash
Lockout Active	Fast Flash
Dehumidification Mode	Flash Code 2
(Future Use)	Flash Code 3
(Future Use)	Flash Code 4
Load Shed	Flash Code 5
ESD	Flash Code 6
(Future Use)	Flash Code 7

Configuration LED (LED2, Yellow)

Description of Operation	Configuration LED, Yellow
No Software Overwritten	Flashing ECM Setting
DIP Switch was Overwritten	Slow Flash
ECM Configuration Mode	Fast Flash

Fault LED (LED1, Red)

Red Fault LED		LED Flash Code*	Lockout	Reset/Remove
ABC Basic Faults	Normal - No Faults	OFF	-	
	Fault - Input	1	No	Auto
	Fault - High Pressure	2	Yes	Hard or Soft
	Fault - Low Pressure	3	Yes	Hard or Soft
	Fault - Freeze Detection FP2	4	Yes	Hard or Soft
	Fault - Freeze Detection FP1	5	Yes	Hard or Soft
	Fault - Condensate Overflow	7	Yes	Hard or Soft
	Fault - Over/Under Voltage	8	No	Auto
Fault - FP1 & FP2 Sensor Error	11	Yes	Hard or Soft	

NOTE: All codes >11 use long flash for tens digit and short flash for the ones digit. 20, 30, 40, 50, etc. are skipped.

Aurora Interface and Diagnostics (AID) Tool

The Aurora Interface and Diagnostics (AID) Tool is a device that is a member of the Aurora network. The AID Tool is used to troubleshoot equipment which uses the Aurora control via Modbus RTU communication. The AID Tool provides diagnostics, fault management, ECM setup, and system configuration capabilities to the Aurora family of controls. An AID Tool is recommended, although not required, for ECM airflow settings. The AID Tool simply plugs into the exterior of the cabinet in the AID Tool port.



ABC Control Board Layout

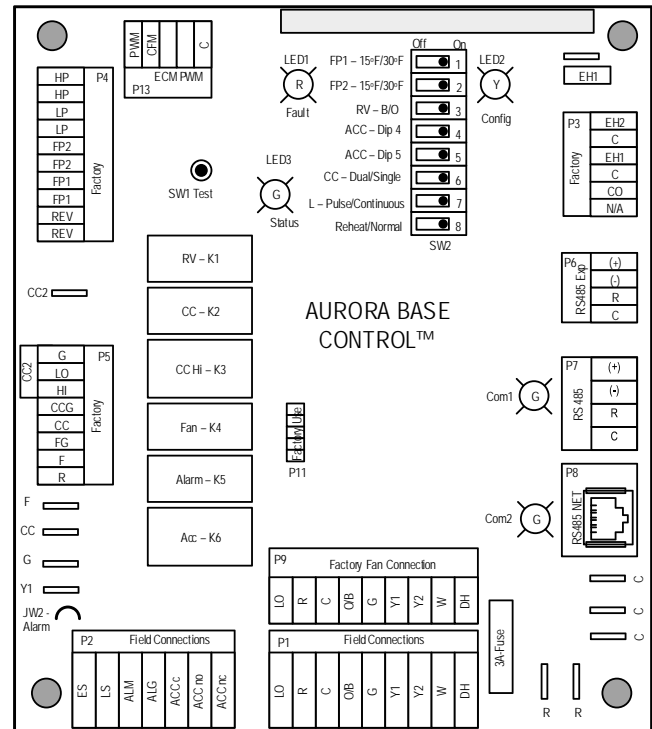

Blower Drive Sheaves

Blower Sheave Adjustment

Follow the procedures listed below if airflow of heat pump is to be changed from factory setting. (Refer to Figure 10.)

1. Loosen the blower motor fastening nuts from the motor mount.
2. Turn the adjusting bolts until the tension is off the drive belt.
3. Remove belt from sheave and loosen allen heat set screw "B".
4. Adjust sheave pitch diameter for desired speed by opening or closing moveable portion in or out in 1/2-turn increments. Do not open more than 5 full turns.
5. Sheave should be mounted with set screw "A" toward the motor. Be sure driven and drive sheaves are in alignment and parallel.
6. Retighten set screw "B" and replace drive belt on sheaves.
7. Turn motor mount adjusting bolts until belt has approximately 1/2-inch of deflection midway between sheaves (4 lbs. tension if measured with gauge, see Figure 11).
8. Retighten motor mounting nuts. Belt tension of a new belt will drop rapidly during the first few hours of operation.
9. Check and readjust as needed.

Figure 10: Blower Motor Sheave Adjustments and Settings

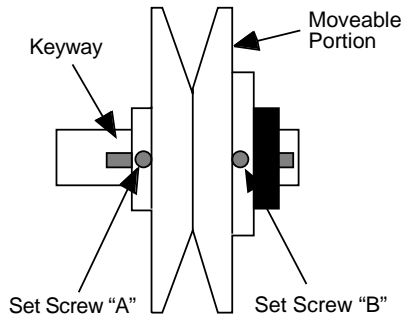
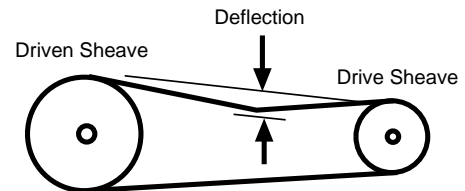

Figure 11: Checking Drive Belt Tension



Unit Startup

Before powering the unit, check the following:

- High voltage is correct and matches nameplate
- Fuses, breakers and wire size are correct
- Low voltage wiring is complete
- Piping has been completed and water system cleaned and flushed
- Air is purged from closed loop system
- Isolation valves are open and water control valves or loop pumps wired
- Condensate line is open and correctly pitched
- Transformer has been switched to lower voltage tap if needed
- Blower rotates freely
- Blower speed is correct
- Air filter is clean and in position
- Service/access panels are in place
- Return air temperature is between 60°F-80°F in heating and 70°F-95°F in cooling
- Air coil has been cleaned

Startup Steps

1. Initiate a control signal to energize the blower motor. Check blower operation.
2. Initiate a control signal to place the unit in the cooling mode. Cooling set point must be set below room temperature.
3. First stage cooling will energize after a time delay. Check for correct rotation of scroll compressors in 120, 080, 095 units. Incorrect rotation will cause unusual noise and low refrigerant pressures. Switch any two power leads at the compressor or contractor to reverse rotation.
4. Be sure the compressor and water control valve or loop pumps are activated.
5. Initiate a control signal to energize second stage cooling.
6. Second stage cooling will energize after a time delay. Check for correct rotation as indicated in step 3.
7. Verify that the water flow rate is correct by measuring pressure drop through the heat exchanger using the P/T plugs and comparing to Water Pressure Drop Table on page 24.
8. Check the temperature of both the supply and discharge water. **Refer to Unit Operating Pressures and Temperatures**
9. Check for an air temperature drop of 15° to 25°F across the air coil, depending on blower speed and entering water temperature.
10. Adjust the cooling setpoint above the room temperature and verify that the compressor and water valve or pumps deactivate.
11. Initiate a control signal to place the unit in the heating mode. Heating setpoint must be set above room temperature.
12. First stage heating will energize after a time delay.
13. Initiate a control signal to energize second stage heating.
14. Second stage heating will energize after a time delay.
15. Check the temperature of both the supply and discharge water. **Refer to Unit Operating Pressures and Temperatures.**
16. Check for an air temperature rise of 20°F to 25°F across the air coil, depending on the blower speed and entering water temperature.
17. Adjust the heating setpoint below room temperature and verify that the compressor and water valve or loop pumps deactivate.
18. During all testing, check for excessive vibration, noise or water leaks.
19. Set system to desired normal operating mode and set temperature to maintain desired comfort level.
20. Instruct the owner/operator in the proper operation of the thermostat and system maintenance.
21. Check belt tension and readjust as necessary after first few hours.

Operating Parameters

Entering Water Temp °F	Water Flow GPM/Ton	Cooling					
		Suction Pressure PSIG	Discharge Pressure PSIG	080-300 Superheat	080-300 Subcooling	Water Temp Rise °F	Air Temp Drop °F DB
50	1.5	110-130	160-190	10-17	13-17	17-22	20-30
	3.0	110-130	160-190	20-30	11-15	8-12	20-30
70	1.5	120-140	260-300	9-13	15-19	17-22	20-30
	3.0	120-140	260-300	9-13	11-15	8-12	20-30
90	1.5	130-150	340-380	8-12	15-19	15-19	15-25
	3.0	130-150	340-380	8-12	11-15	7-11	15-25

Entering Water Temp °F	Water Flow GPM/Ton	Heating					
		Suction Pressure PSIG	Discharge Pressure PSIG	080-300 Superheat	080-300 Subcooling	Water Temp Drop °F	Air Temp Rise °F DB
30	1.5	-	-	-	-	-	-
	3.0	60-80	280-310	10-14	5-12	4-8	20-30
50	1.5	80-110	300-330	8-12	5-12	6-12	20-30
	3.0	80-110	300-330	8-12	5-12	6-12	20-30
70	1.5	110-140	330-360	8-12	1-8	10-15	30-40
	3.0	110-140	330-360	8-12	1-8	10-15	30-40

Note: Cooling performance based on entering air temperatures of 80° F DB, 67° F WB.
 Heating performance based on entering air temperature of 70° F DB.

7/25/07

Pressure Drop

Model	GPM	Pressure Drop (psi)				
		30°F	50°F	70°F	90°F	110°F
080	10.0	2.48	2.36	2.29	2.21	2.14
	16.0	5.96	5.62	5.22	4.89	4.69
	22.0	10.91	10.38	9.73	9.12	8.50
095	12.0	2.22	2.00	1.92	1.83	1.67
	18.0	4.62	4.02	3.80	3.75	3.65
	24.0	7.31	6.81	5.80	5.60	5.19
120	16.0	2.03	1.93	1.88	1.80	1.50
	22.0	3.69	3.58	3.40	3.19	2.99
	28.0	5.58	5.50	5.32	5.00	4.84
160	20.0	1.20	1.19	1.18	1.17	1.16
	28.0	2.64	2.50	2.37	2.24	2.12
	35.0	3.72	3.65	3.41	3.36	3.21
180	22.0	1.50	1.50	1.50	1.50	1.50
	34.0	3.95	3.90	3.85	3.80	3.75
	45.0	6.40	6.10	6.00	5.80	5.70
240	30.0	0.90	0.82	0.75	0.69	0.63
	45.0	2.22	2.06	1.91	1.77	1.64
	60.0	3.47	3.29	3.06	2.88	2.40
300	35.0	1.84	1.60	1.39	1.21	1.05
	56.0	4.09	3.88	3.69	3.51	3.33
	75.0	6.10	5.95	5.77	5.45	5.10

Preventive Maintenance

Water Coil Maintenance

1. Keep all air out of the water. An open loop system should be checked to ensure that the well head is not allowing air to infiltrate the water line. Lines should always be airtight.
2. Keep the system under pressure at all times. It is recommended in open loop systems that the water control valve be placed in the discharge line to prevent loss of pressure during off cycles. Closed loop systems must have positive static pressure or air vents may draw air into the system.

NOTES: If the installation is performed in an area with a known high mineral content (125 P.P.M. or greater) in the water, it is best to establish with the owner a periodic maintenance schedule so the coil can be checked regularly. Should periodic coil cleaning be necessary, use standard coil cleaning procedures which are compatible with either the cupronickel or copper water lines. Generally, the more water flowing through the unit, the less chance for scaling.

Other Maintenance

Filters

Filters must be clean to obtain maximum performance. They should be inspected every two to three months under normal operating conditions and be replaced when necessary. Units should never be operated without a filter.

Condensate Drain

In areas where airborne bacteria produce a residual buildup in the drain pan, it may be necessary to chemically treat the pan to minimize the problem. The condensate drain can pick up lint and dirt, especially with dirty filters. Inspect twice a year to avoid the possibility of overflow.

Air Coil

The air coil must be clean to obtain maximum performance. Check once a year under normal operating conditions and brush, vacuum or chemically clean the air coil if necessary. Care must be taken not to damage or disturb the aluminum fins while cleaning.



CAUTION: Fin edges are sharp.

Drive Belts

Check periodically for proper tension.

Replacement Procedures

Obtaining Parts

Contact your distributor for service or replacement parts required.

In-warranty Material Return

Material may not be returned except by permission of authorized service personnel. Contact your local distributor for warranty return authorization and assistance.



Product: **G Series Commercial**
Type: Water Source/Geothermal Heat Pump
Size: 7-25 Tons

Document Type: Installation Manual
Part Number: IM1021AG1B
Release Date: 06/15