



---

## ARBOR BASE SERIES COMMERCIAL

Geothermal/Water Source Heat Pumps  
0.5-6 Tons

Submittal Data  
English Language  
IP/Metric Units  
SD1201AZB 03/16

**GEOSTAR**

Contractor: \_\_\_\_\_ P.O.: \_\_\_\_\_

Engineer: \_\_\_\_\_

Project Name: \_\_\_\_\_ Unit Tag: \_\_\_\_\_

**Arbor Base Series Commercial  
Geothermal/Water Source Heat Pumps  
0.5-6 Tons, 60Hz**



## Model Nomenclature

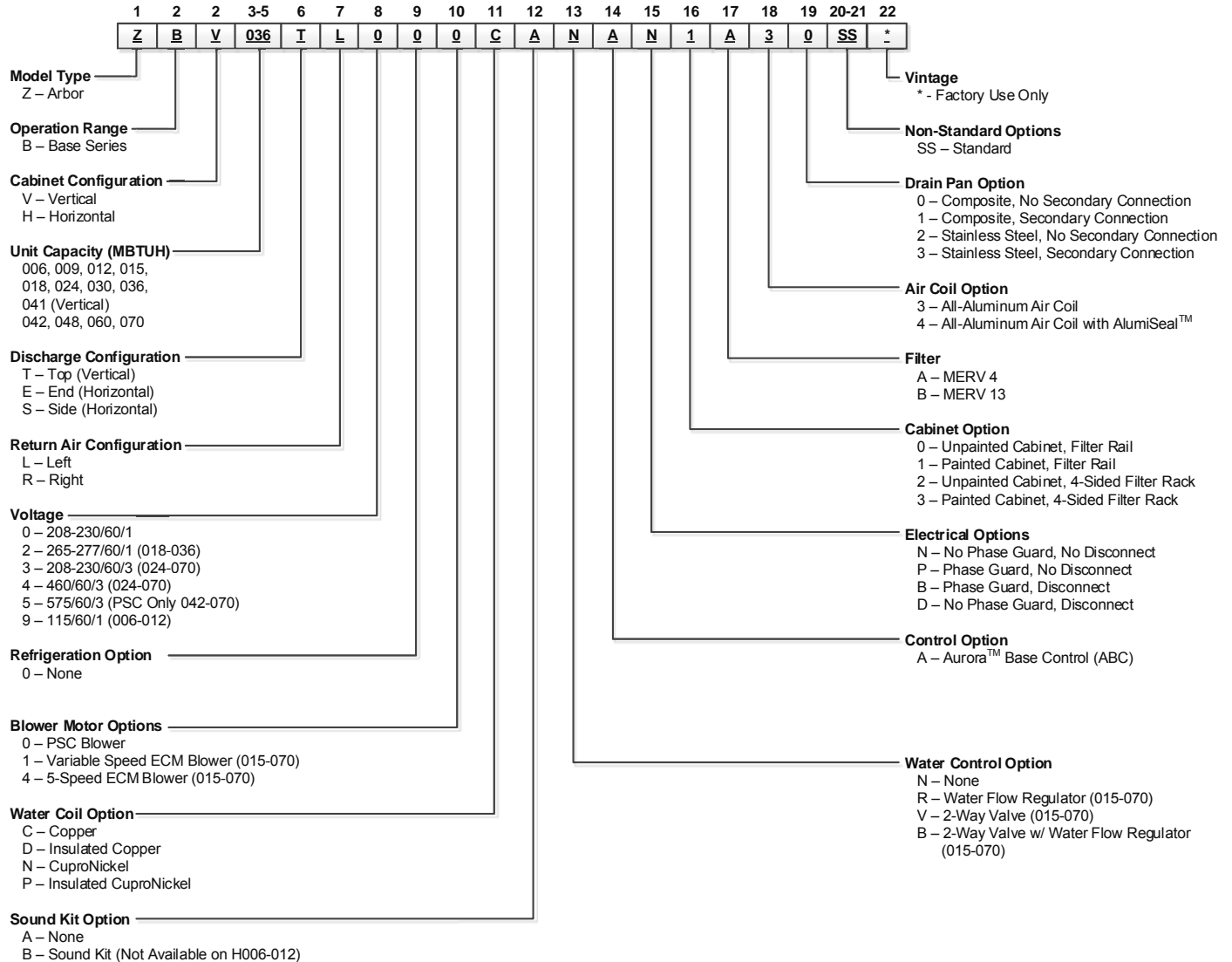

**Note:** Phase Guard Only Available on 208-230/60/3 and 460/60/3  
Some options not available in ZBV041.



The manufacturer works continually to improve its products. As a result, the design and specifications of each product at the time of order may be changed without notice. Purchaser's approval of this data set signifies that the equipment is acceptable under the provisions of the job specification. Statements and other information contained herein are not express warranties and do not form the basis of any bargain between the parties, but are merely the manufacturer's opinion or commendation of its products.

Contractor: \_\_\_\_\_ P.O.: \_\_\_\_\_

Engineer: \_\_\_\_\_

Project Name: \_\_\_\_\_ Unit Tag: \_\_\_\_\_

**Arbor Base Series Commercial  
Geothermal/Water Source Heat Pumps  
0.5-6 Tons, 60Hz**



## AHRI Data

**PSC Motors  
AHRI/ASHRAE/ISO 13256-1  
English (IP) Units**

Model	Flow Rate		Water Loop Heat Pump				Ground Water Heat Pump				Ground Loop Heat Pump			
			Cooling EWT 86°F		Heating EWT 68°F		Cooling EWT 59°F		Heating EWT 50°F		Cooling EWT 77°F		Heating EWT 32°F	
	gpm	cfm	Capacity Btuh	EER Btuh/W	Capacity Btuh	COP	Capacity Btuh	EER Btuh/W	Capacity Btuh	COP	Capacity Btuh	EER Btuh/W	Capacity Btuh	COP
006	2.0	250	7,100	13.4	8,000	4.3	8,400	21.3	6,800	3.8	7,400	15.5	5,400	3.2
009	3.0	350	8,100	12.2	11,400	4.6	9,900	19.2	9,600	4.0	8,900	14.5	7,600	3.4
012	3.0	400	10,200	12.2	15,200	4.4	12,200	18.2	12,600	3.9	11,200	14.2	10,200	3.5
015	4.0	500	13,200	12.5	15,400	4.5	16,000	20.0	13,000	4.0	14,000	15.3	10,400	3.2
018	5.0	600	17,300	13.4	19,000	4.3	19,800	20.5	16,000	3.7	18,000	15.4	12,600	3.2
024	6.0	800	22,900	13.0	26,000	4.5	27,000	19.8	22,600	4.0	24,500	14.8	17,000	3.3
030	8.0	1000	28,400	13.8	34,000	4.5	33,500	21.0	28,000	4.0	30,000	16.0	21,000	3.3
036	9.0	1150	34,500	14.0	43,800	4.7	40,000	22.0	35,600	4.2	36,000	16.3	26,000	3.3
041	11.0	1100	37,600	13.5	48,000	4.3	44,500	20.4	38,500	3.8	40,000	15.0	28,500	3.2
042	11.0	1400	39,200	13.2	51,000	4.7	47,000	20.4	41,400	4.3	42,000	15.2	30,500	3.3
048	12.0	1600	47,200	13.0	59,000	4.6	57,000	19.8	48,000	4.0	49,500	15.0	36,500	3.3
060	15.0	1900	57,000	13.5	66,000	4.3	67,000	21.0	55,000	4.0	58,000	15.2	43,000	3.3
070	18.0	2100	66,000	14.0	80,000	4.5	75,000	20.5	64,000	4.0	68,000	15.6	49,000	3.3

10/15/15

**Variable Speed ECM, 5 Speed ECM motor  
AHRI/ASHRAE/ISO 13256-1  
English (IP) Units**

Model	Flow Rate		Water Loop Heat Pump				Ground Water Heat Pump				Ground Loop Heat Pump			
			Cooling EWT 86°F		Heating EWT 68°F		Cooling EWT 59°F		Heating EWT 50°F		Cooling EWT 77°F		Heating EWT 32°F	
	gpm	cfm	Capacity Btuh	EER Btuh/W	Capacity Btuh	COP	Capacity Btuh	EER Btuh/W	Capacity Btuh	COP	Capacity Btuh	EER Btuh/W	Capacity Btuh	COP
015	4.0	500	13,800	13.2	16,100	4.6	16,000	21.0	13,400	4.1	14,200	15.7	11,000	3.3
018	5.0	600	17,300	14.2	19,000	4.5	19,800	22.0	16,000	3.9	18,000	16.2	12,600	3.3
024	6.0	800	22,900	13.6	26,000	4.7	27,000	20.8	22,600	4.2	24,500	15.6	17,000	3.5
030	8.0	900	28,400	14.7	34,000	4.7	33,500	22.5	28,000	4.2	30,000	17.0	21,000	3.5
036	9.0	1150	34,500	14.5	43,800	4.9	40,000	23.0	35,600	4.4	36,000	17.0	26,000	3.5
041	11.0	1300	39,000	13.9	48,500	4.7	45,000	21.0	38,500	4.1	41,000	16.0	28,500	3.4
042	11.0	1400	39,200	14.2	51,000	4.9	47,000	22.0	41,400	4.5	42,000	16.6	30,500	3.5
048	12.0	1600	47,200	14.0	59,000	4.8	57,000	21.0	48,000	4.2	49,500	16.0	36,500	3.5
060	15.0	1900	57,000	14.0	66,000	4.6	67,000	22.0	55,000	4.2	58,000	16.0	43,000	3.5
070	18.0	2100	66,000	14.6	80,000	4.7	75,000	22.0	64,000	4.2	68,000	16.6	49,000	3.5

10/15/15



The manufacturer works continually to improve its products. As a result, the design and specifications of each product at the time of order may be changed without notice. Purchaser's approval of this data set signifies that the equipment is acceptable under the provisions of the job specification. Statements and other information contained herein are not express warranties and do not form the basis of any bargain between the parties, but are merely the manufacturer's opinion or commendation of its products.

Contractor: \_\_\_\_\_ P.O.: \_\_\_\_\_

Engineer: \_\_\_\_\_

Project Name: \_\_\_\_\_ Unit Tag: \_\_\_\_\_

**Arbor Base Series Commercial  
Geothermal/Water Source Heat Pumps  
0.5-6 Tons, 60Hz**



# Vertical Dimensional Data

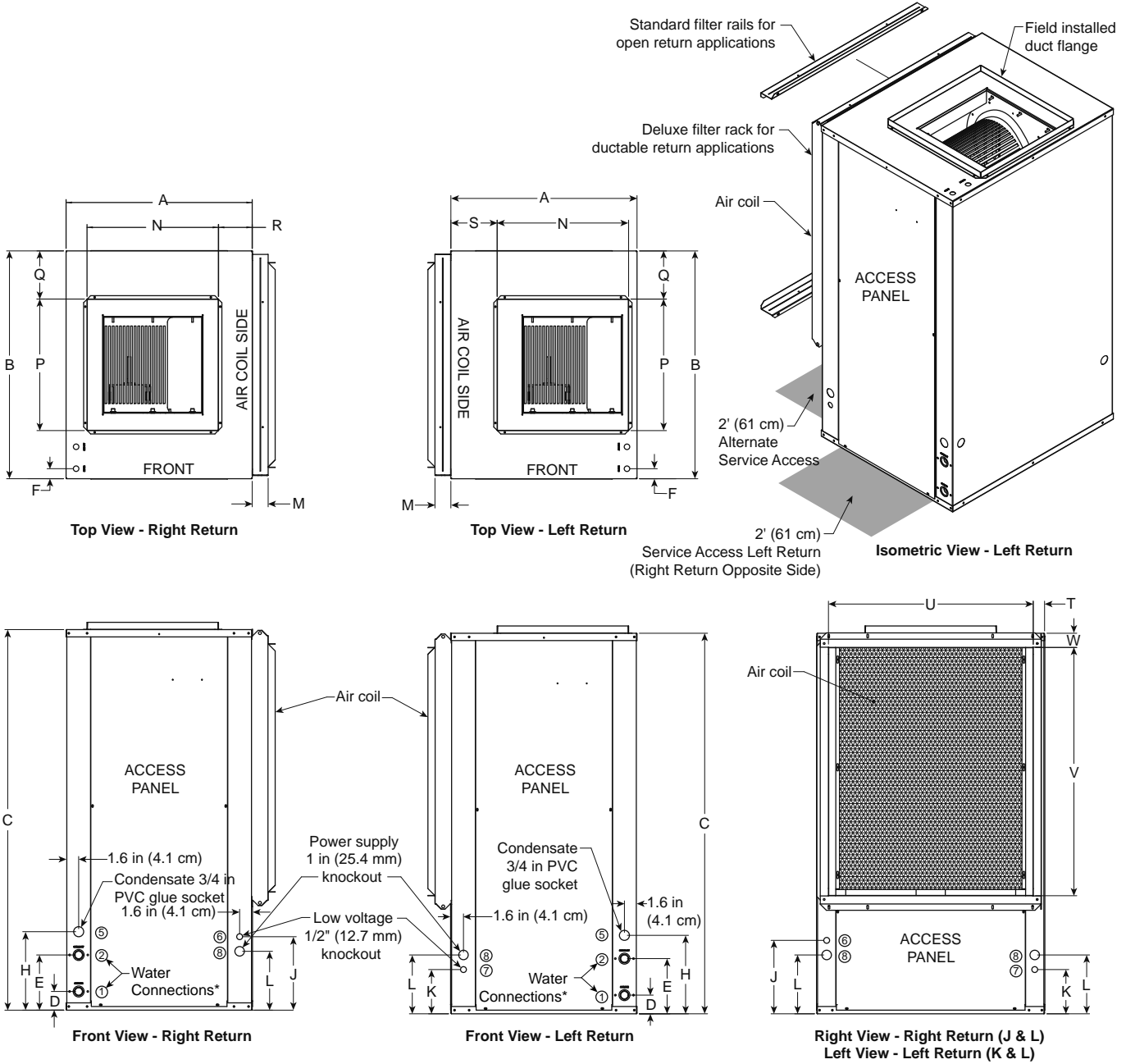

**NOTE:** \* Water connections protrude approximately 1.5 in. (3.81cm) from cabinet.

The manufacturer works continually to improve its products. As a result, the design and specifications of each product at the time of order may be changed without notice. Purchaser's approval of this data set signifies that the equipment is acceptable under the provisions of the job specification. Statements and other information contained herein are not express warranties and do not form the basis of any bargain between the parties, but are merely the manufacturer's opinion or commendation of its products.

Contractor: \_\_\_\_\_ P.O.: \_\_\_\_\_

Engineer: \_\_\_\_\_

Project Name: \_\_\_\_\_ Unit Tag: \_\_\_\_\_



## Vertical Dimensional Data cont.

Vertical Models		Overall Cabinet			Water Connections				Electrical Knockouts			Filter Rack Width
									6	7	8	
		A	B	C	1	2	5	Loop	J	K	L	
	Width	Depth	Height*	In	Out	Condensate	Water FPT	1/2" cond	1/2" cond	1" cond		
								Low Voltage	Low Voltage	Power Supply		
006-012	in.	19.2	19.2	24.2	2.6	5.6	8.8	1/2"	7.4	3.4	5.4	2.2
	cm.	48.8	48.8	61.5	6.6	14.2	22.4	12.7 mm	18.8	8.6	13.7	5.6
015-018	in.	22.5	22.2	30.2	2.6	7.6	10.8	3/4"	9.4	5.4	7.4	2.2
	cm.	57.2	56.4	76.7	6.6	19.3	27.4	19.1 mm	23.9	13.7	18.8	5.6
024-030	in.	22.5	22.2	36.2	2.6	7.6	10.8	3/4"	9.4	5.4	7.4	2.2
	cm.	57.2	56.4	91.9	6.6	19.3	27.4	19.1 mm	23.9	13.7	18.8	5.6
036	in.	22.5	26.2	40.2	2.6	7.6	10.8	3/4"	10.1	6.1	8.1	2.2
	cm.	57.2	66.5	102.1	6.6	19.3	27.4	19.1 mm	25.7	15.5	20.6	5.6
041	in.	21.5	21.5	40.2	2.6	7.6	10.8	3/4"	9.4	5.4	7.4	1.2
	cm.	54.6	54.6	102.1	6.6	19.3	27.4	19.1 mm	23.9	13.7	18.8	3.0
042-048	in.	22.5	26.2	44.2	2.6	7.6	10.8	3/4"	10.1	6.1	8.1	2.2
	cm.	57.2	66.5	112.3	6.6	19.3	27.4	19.1 mm	25.7	15.5	20.6	5.6
060	in.	25.5	31.2	44.2	2.6	7.6	10.8	1"	10.1	6.1	8.1	2.2
	cm.	64.8	79.2	112.3	6.6	19.3	27.4	25.4 mm	25.7	15.5	20.6	5.6
070	in.	25.5	31.2	48.2	2.6	7.6	10.8	1"	10.1	6.1	8.1	2.2
	cm.	64.8	79.2	122.4	6.6	19.3	27.4	25.4 mm	25.7	15.5	20.6	5.6

Vertical Models		Discharge Connection duct flange installed (±0.10 in)					**Return Connection using deluxe filter rack (±0.10 in)			
		N	P	Q	R	S	T	U	V	W
		Supply Width	Supply Depth					Return Depth	Return Height	
006-012	in.	10.0	10.0	4.6	4.4	7.8	2.4	14.3	10.1	2.0
	cm.	25.4	25.4	11.7	11.2	19.8	6.1	36.3	25.7	5.1
015-018	in.	14.0	14.0	4.1	4.3	7.7	2.1	18.1	14.0	2.0
	cm.	35.6	35.6	10.4	10.9	19.6	5.3	46.0	35.6	5.1
024-030	in.	14.0	14.0	4.1	4.3	7.7	2.1	18.1	20.0	2.0
	cm.	35.6	35.6	10.4	10.9	19.6	5.3	46.0	50.8	5.1
036	in.	14.0	14.0	6.1	4.5	7.7	2.1	22.1	22.1	2.0
	cm.	35.6	35.6	15.5	11.4	19.6	5.3	56.1	56.1	5.1
041	in.	14.0	14.0	3.8	3.5	6.7	0.6	20.2	28.0	0.6
	cm.	35.6	35.6	9.7	8.9	17.0	1.5	51.3	71.1	1.5
042-048	in.	18.0	18.0	4.1	2.1	3.9	2.1	22.1	26.1	2.0
	cm.	45.7	45.7	10.4	5.3	9.9	5.3	56.1	66.3	5.1
060	in.	18.0	18.0	6.6	4.6	6.3	1.6	28.1	26.0	2.0
	cm.	45.7	45.7	16.8	11.7	16.0	4.1	71.4	66.0	5.1
070	in.	18.0	18.0	6.6	4.6	6.3	1.6	28.1	30.0	2.0
	cm.	45.7	45.7	16.8	11.7	16.0	4.1	71.4	76.2	5.1

Condensate is 3/4" PVC female glue socket and is switchable from side to front.

10/15/15

\*Discharge flange is field installed and extends 1" (25.4 mm) from top of cabinet.

\*\*Vertical units shipped with standard 2" (field adjustable to 1") open application filter rack extending 2.2" from unit and is not suitable for duct connection.

For ductable return connection applications, order the deluxe 2" (field adjustable to 1") duct collar/filter rack which extends 3.25

## Vertical Disconnect

When using disconnect, do not use dimension L from the standard vertical dimensional data. Use dimension LL from the vertical disconnect dimensional data.

Vertical Models	LL
015-018	15.8 [40.1]
024-030	18.8 [47.8]
036	15.3 [38.9]
042-048	13.8 [35.1]
060	14.3 [36.3]
070	14.3 [36.3]

Dimensions in inches [cm]

\* Models 006-012 - Externally Mounted Disconnect

\*\*UBV-041 - Disconnect not available

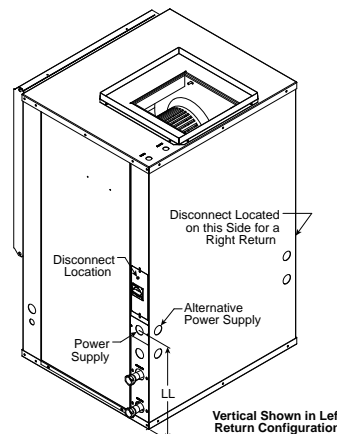

The manufacturer works continually to improve its products. As a result, the design and specifications of each product at the time of order may be changed without notice. Purchaser's approval of this data set signifies that the equipment is acceptable under the provisions of the job specification. Statements and other information contained herein are not express warranties and do not form the basis of any bargain between the parties, but are merely the manufacturer's opinion or commendation of its products.

Contractor: \_\_\_\_\_ P.O.: \_\_\_\_\_

Engineer: \_\_\_\_\_

Project Name: \_\_\_\_\_ Unit Tag: \_\_\_\_\_

**Arbor Base Series Commercial  
Geothermal/Water Source Heat Pumps  
0.5-6 Tons, 60Hz**



# Horizontal Dimensional Data

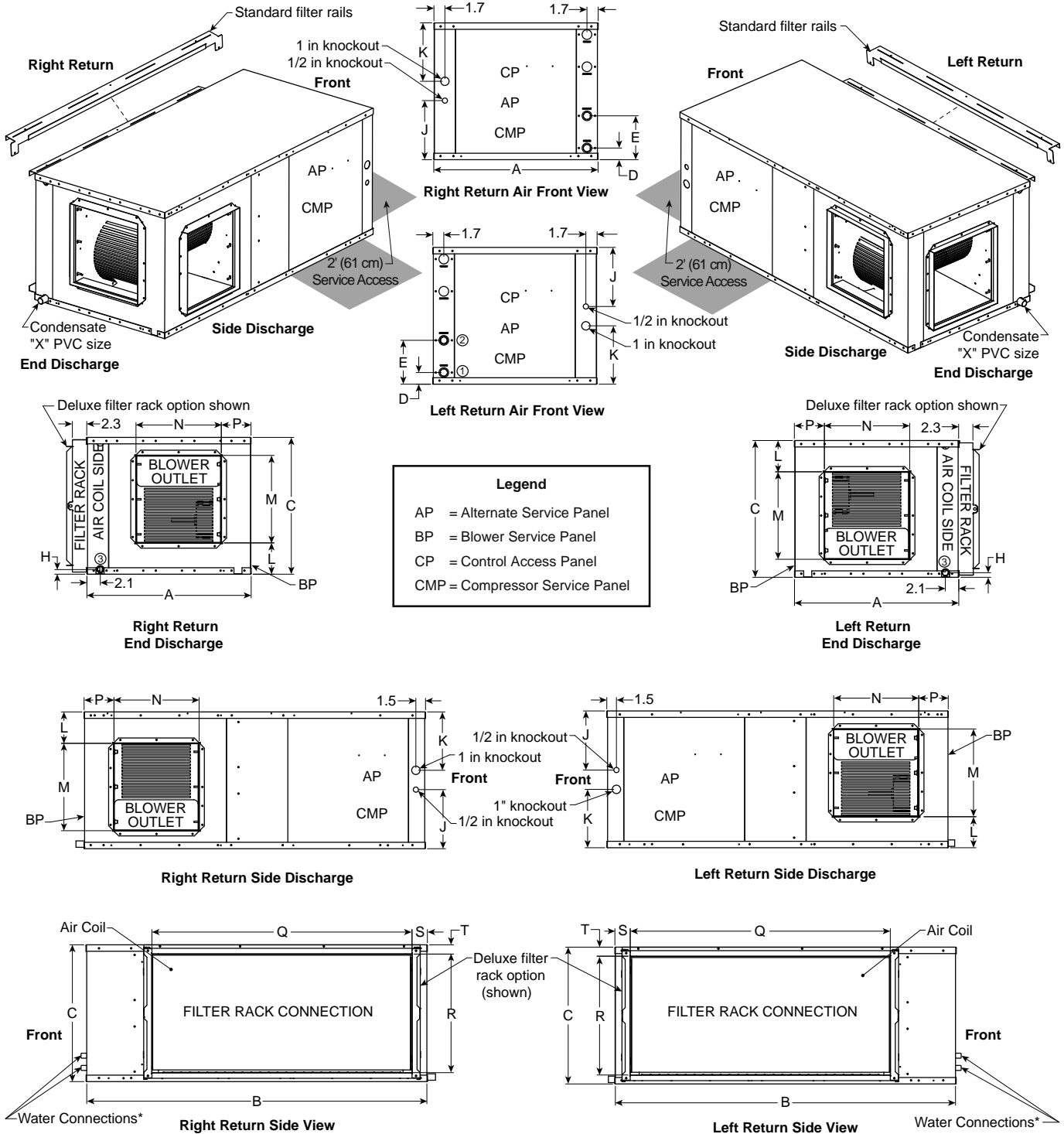

**NOTE:** \* Water connections protrude approximately 1.5 in. from cabinet.

The manufacturer works continually to improve its products. As a result, the design and specifications of each product at the time of order may be changed without notice. Purchaser's approval of this data set signifies that the equipment is acceptable under the provisions of the job specification. Statements and other information contained herein are not express warranties and do not form the basis of any bargain between the parties, but are merely the manufacturer's opinion or commendation of its products.

Contractor: \_\_\_\_\_ P.O.: \_\_\_\_\_

Engineer: \_\_\_\_\_

Project Name: \_\_\_\_\_ Unit Tag: \_\_\_\_\_



## Horizontal Dimensional Data cont.

Horizontal Models	Overall Cabinet			Water Connections				Electrical Knockouts		
	A	B	C	1	2	3	Loop	J	K	
	Width	Depth	Height*	D	E	H		1/2 in. cond	1 in. cond	
006-012**	in.	19.2	35.0	12.1	1.8	4.8	3.6	1/2 in.	7.4	7.5
	cm.	48.8	88.9	30.7	4.6	12.2	9.1	12.70 mm	18.8	19.1
015-018	in.	22.5	35.0	17.2	1.8	6.8	0.8	3/4 in.	7.1	7.1
	cm.	57.2	88.9	43.7	4.6	17.3	2.0	19.05 mm	18.0	18.0
024-030	in.	22.5	42.0	17.2	1.8	6.8	0.8	3/4 in.	7.1	7.1
	cm.	57.2	106.7	43.7	4.6	17.3	2.0	19.05 mm	18.0	18.0
036	in.	22.5	42.0	19.2	1.8	6.8	0.8	3/4 in.	9.2	7.1
	cm.	57.2	106.7	48.8	4.6	17.3	2.0	19.05 mm	23.4	18.0
042-048	in.	22.5	45.0	19.2	1.8	6.8	0.8	3/4 in.	9.2	7.1
	cm.	57.2	114.3	48.8	4.6	17.3	2.0	19.05 mm	23.4	18.0
060	in.	25.5	48.0	21.2	1.8	6.8	0.8	1 in.	9.2	9.1
	cm.	64.8	121.9	53.8	4.6	17.3	2.0	25.4 mm	23.4	23.1
070	in.	25.5	53.0	21.2	1.8	6.8	0.8	1 in.	9.2	9.1
	cm.	64.8	134.6	53.8	4.6	17.3	2.0	25.4 mm	23.4	23.1

Horizontal Models	Discharge Connection duct flange installed (±0.10 in)				Return Connection using deluxe filter rack option (±0.10 in)				PVC Size	
	L	M	N	P	Q	R	S	T	X	
		Supply Width	Supply Depth		Return Depth	Return Height				
006-012**	in.	2.3	8.0	10.0	2.7	22.5	9.4	2.4	1.4	1/2 in.
	cm.	5.8	20.3	25.4	6.9	57.2	23.9	6.1	3.6	1.3
015-018	in.	5.7	10.5	9.4	4.9	16.4	14.5	2.0	1.4	3/4 in.
	cm.	14.5	26.7	23.9	12.4	41.7	36.8	5.1	3.6	1.9
024-030	in.	5.7	10.5	9.4	4.9	23.4	14.5	2.0	1.4	3/4 in.
	cm.	14.5	26.7	23.9	12.4	59.4	36.8	5.1	3.6	1.9
036	in.	6.7	10.5	9.4	4.9	27.4	16.5	2.0	1.4	3/4 in.
	cm.	17.0	26.7	23.9	12.4	69.6	41.9	5.1	3.6	1.9
042-048	in.	4.2	13.6	13.2	2.4	30.4	16.5	2.0	1.5	3/4 in.
	cm.	10.7	34.5	33.5	6.1	77.2	41.9	5.1	3.8	1.9
060	in.	4.8	13.6	13.2	4.6	35.4	18.7	2.3	1.3	3/4 in.
	cm.	12.2	34.5	33.5	11.7	89.9	47.5	5.8	3.3	1.9
070	in.	4.8	13.6	13.2	4.6	40.4	18.5	2.3	1.4	3/4 in.
	cm.	12.2	34.5	33.5	11.7	102.6	47.0	5.8	3.6	1.9

09/26/12

Horizontal units shipped with standard 2 in. (field adjustable to 1 in.) open application filter rail extending 2.2 in. from the unit and is not suitable for duct connection. For ductable return connection applications, order the 2 in. (field adjustable to 1 in.) duct collar/filter rack which extends to 3.25 in. from the unit and is suitable for duct connections.

\*\* H006-012 offers a lifted drain pan that allows the trap to be installed without additional ceiling height required.

## Horizontal Disconnect

When using disconnect, do not use dimension K from the standard horizontal dimensional data. Use dimension KK from the horizontal disconnect dimensional data.

Horizontal Models	KK
015-018	8.2 [20.8]
024-030	8.2 [20.8]
036	9.2 [23.4]
042-048	9.2 [23.4]
060	11.2 [28.4]
070	10.2 [25.9]

Dimensions in inches [cm]

\* Models 006-012 - Externally Mounted Disconnect

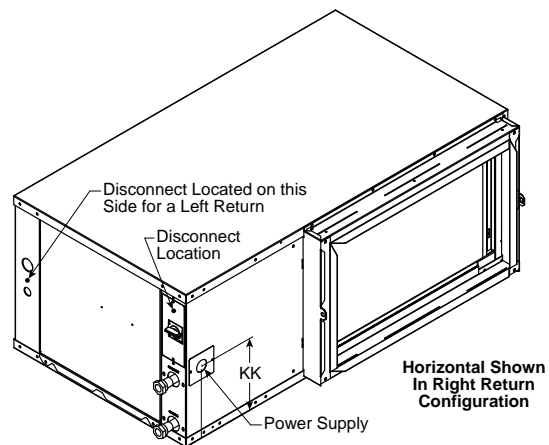

The manufacturer works continually to improve its products. As a result, the design and specifications of each product at the time of order may be changed without notice. Purchaser's approval of this data set signifies that the equipment is acceptable under the provisions of the job specification. Statements and other information contained herein are not express warranties and do not form the basis of any bargain between the parties, but are merely the manufacturer's opinion or commendation of its products.

Contractor: \_\_\_\_\_ P.O.: \_\_\_\_\_

Engineer: \_\_\_\_\_

Project Name: \_\_\_\_\_ Unit Tag: \_\_\_\_\_



## Hanger Bracket Locations

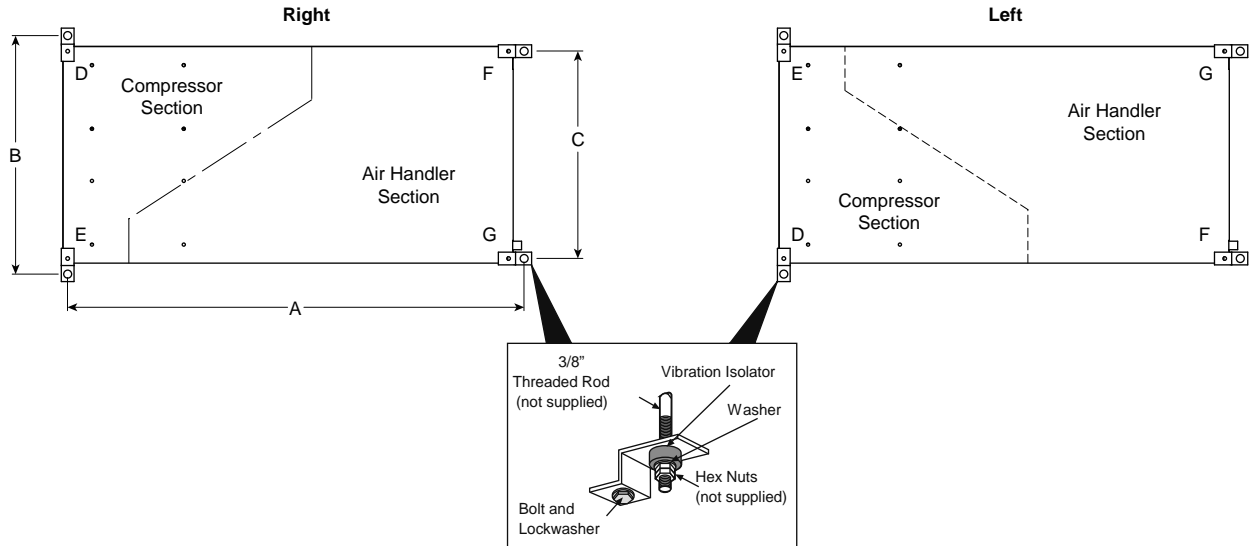

### Hanger Dimensions

Model	Hanger Kit Part Number	Unit Hanger Dimensions			
		A	B	C	
006-012	99S500A04	in.	35.8	21.8	18.1
		cm.	90.9	55.4	46.0
015-018	99S500A04	in.	35.8	25.1	21.4
		cm.	90.9	63.8	54.4
024-030	99S500A04	in.	42.8	25.1	21.4
		cm.	108.6	63.8	54.4
036	99S500A04	in.	42.8	25.1	21.4
		cm.	108.7	63.8	54.4
042-048	99S500A04	in.	45.8	25.1	21.4
		cm.	116.3	63.8	54.4
060	99S500A04	in.	48.8	28.1	24.4
		cm.	124.0	71.4	62.0
070	99S500A04	in.	53.8	28.1	24.4
		cm.	136.7	71.4	62.0

09/26/12

### Weight Distribution Table

Model	Vertical Shipping Weight	Horizontal Shipping Weight	Horizontal Weight Distribution				
			Front		Back		
			D	E	F	G	
006-012	lbs	111	112	44	21	19	28
	kg	50	51	20	10	9	12
015-018	lbs	171	176	32	67	32	45
	kg	78	80	15	30	15	20
024	lbs	245	242	47	85	45	65
	kg	111	110	21	39	20	29
030	lbs	245	242	47	85	45	65
	kg	111	110	21	39	20	29
036	lbs	267	265	60	95	50	60
	kg	121	120	27	43	23	27
041	lbs	243	N/A				
	kg	110	N/A				
042	lbs	305	310	68	105	60	77
	kg	138	141	31	48	27	35
048	lbs	305	310	68	105	60	77
	kg	138	141	31	48	27	35
060	lbs	344	350	77	115	68	90
	kg	156	159	35	52	31	41
070	lbs	357	378	80	130	73	95
	kg	162	171	36	59	33	43

10/15/2015

The manufacturer works continually to improve its products. As a result, the design and specifications of each product at the time of order may be changed without notice. Purchaser's approval of this data set signifies that the equipment is acceptable under the provisions of the job specification. Statements and other information contained herein are not express warranties and do not form the basis of any bargain between the parties, but are merely the manufacturer's opinion or commendation of its products.



Contractor: \_\_\_\_\_ P.O.: \_\_\_\_\_

Engineer: \_\_\_\_\_

Project Name: \_\_\_\_\_ Unit Tag: \_\_\_\_\_



## Physical Data

Model	Single Speed Models													
	006	009	012	015	018	024	030	036	041	042	048	060	070	
Compressor (1 each)	Rotary							Reciprocating						
Factory Charge R410A, oz [kg] Vertical	24 [0.68]	26 [0.74]	26 [0.74]	30 [0.85]	34 [0.96]	36 [1.02]	42 [1.19]	60 [1.70]	60 [1.70]	60 [1.70]	66 [1.87]	76 [2.15]	88 [2.49]	
Factory Charge R410A, oz [kg] Horizontal	24 [0.68]	24 [0.68]	26 [0.74]	30 [0.85]	34 [0.96]	44 [1.25]	48 [1.36]	60 [1.70]	N/A	56 [1.59]	60 [1.70]	84 [2.38]	88 [2.49]	
Blower Motor & Blower														
Blower Motor Type/Speeds	VS ECM	Not Available			Variable Speed									
	5 Speed ECM	Not Available			5 Speed									
	PSC	4 Speeds			3 Speed									
Blower Motor-hp [W]	VS ECM	Not Available			1/2 [373]	1/2 [373]	1/2 [373]	1/2 [373]	1/2 [373]	1/2 [373]	1/2 [373]	1/2 [373]	1 [746]	1 [746]
	5 Speed ECM	Not Available			1/2 [373]	1/2 [373]	1/2 [373]	1/2 [373]	1/2 [373]	1/2 [373]	1 [746]	1 [746]	1 [746]	1 [746]
	PSC	1/10 [75]	1/10 [75]	1/10 [75]	1/6 [134]	1/6 [134]	1/5 [149]	1/3 [249]	1/2 [373]	1/3 [249]	1/2 [373]	1/2 [373]	1 [746]	1 [746]
Blower Wheel Size (Dia x W), in. [mm]	VS ECM	Not Available			9 x 7 [229 x 178]	9 x 7 [229 x 178]	9 x 7 [229 x 178]	9 x 7 [229 x 178]	9 x 7 [229 x 178]	9 x 7 [229 x 178]	9 x 7 [229 x 178]	11 x 10 [279 x 254]	11 x 10 [279 x 254]	11 x 10 [279 x 254]
	5 Speed ECM	Not Available			9 x 7 [229 x 178]	9 x 7 [229 x 178]	9 x 7 [229 x 178]	9 x 7 [229 x 178]	9 x 7 [229 x 178]	9 x 7 [229 x 178]	11 x 10 [279 x 254]	11 x 10 [279 x 254]	11 x 10 [279 x 254]	11 x 10 [279 x 254]
	PSC	6 x 8 [152 x 203]	6 x 8 [152 x 203]	6 x 8 [152 x 203]	9 x 7 [229 x 178]	9 x 7 [229 x 178]	9 x 7 [229 x 178]	9 x 7 [229 x 178]	9 x 7 [229 x 178]	9 x 7 [229 x 178]	10 x 10 [254 x 254]	10 x 10 [254 x 254]	11 x 10 [279 x 254]	11 x 10 [279 x 254]
Coax and Water Piping														
Water Connection Size - FPT - in [mm]	1/2" [12.7]	1/2" [12.7]	1/2" [12.7]	3/4" [19.1]	3/4" [19.1]	3/4" [19.1]	3/4" [19.1]	3/4" [19.1]	3/4" [19.1]	3/4" [19.1]	3/4" [19.1]	3/4" [19.1]	1" [25.4]	1" [25.4]
Coax & Piping Water Volume - gal [l]	0.4 [1.49]	0.4 [1.49]	0.4 [1.49]	0.4 [1.49]	0.4 [1.49]	0.4 [1.49]	0.75 [2.83]	0.9 [3.41]	0.9 [3.41]	0.9 [3.41]	1.25 [4.72]	1.5 [5.68]	1.5 [5.68]	
Vertical														
Air Coil Dimensions (H x W), in. [mm]	12 x 14 [305 x 356]	12 x 14 [305 x 356]	12 x 14 [305 x 356]	16 x 16 [406 x 406]	16 x 16 [406 x 406]	22 x 16 [559 x 406]	22 x 16 [559 x 406]	24 x 20 [610 x 508]	26 x 16 [660 x 406]	28 x 20 [711 x 508]	28 x 20 [711 x 508]	28 x 25 [711 x 635]	32 x 25 [813 x 635]	
Air Coil Total Face Area, ft2 [m2]	1.17 [0.11]	1.17 [0.11]	1.17 [0.11]	1.8 [0.17]	1.8 [0.17]	2.4 [0.2]	2.4 [0.2]	3.3 [0.307]	2.9 [0.269]	3.9 [0.362]	3.9 [0.362]	4.9 [0.455]	5.6 [0.520]	
Air Coil Tube Size, in [mm]	3/8 [9.5]	3/8 [9.5]	3/8 [9.5]	3/8 [9.5]	3/8 [9.5]	3/8 [9.5]	3/8 [9.5]	3/8 [9.5]	3/8 [9.5]	3/8 [9.5]	3/8 [9.5]	3/8 [9.5]	3/8 [9.5]	
Air Coil Number of rows	3	3	3	3	3	3	3	3	4	3	3	3	3	
Filter Standard - 1" [25mm] MERV4 Throwaway, in [mm]	12 x 16 [305 x 406]	12 x 16 [305 x 406]	12 x 16 [305 x 406]	16 x 20 [406 x 508]	16 x 20 [406 x 508]	22 x 20 [559 x 508]	22 x 20 [559 x 508]	24 x 24 [610 x 610]	28 x 20 [711 x 508]	28 x 24 [711 x 610]	28 x 24 [711 x 610]	28 x 30 [711 x 762]	32x 30 [813 x 762]	
Filter Standard - 2" [51mm] Pleated MERV13 Throwaway, in [mm]	12 x 16 [305 x 406]	12 x 16 [305 x 406]	12 x 16 [305 x 406]	16 x 20 [406 x 508]	16 x 20 [406 x 508]	22 x 20 [559 x 508]	22 x 20 [559 x 508]	24 x 24 [610 x 610]	N/A	28 x 24 [711 x 610]	28 x 24 [711 x 610]	28 x 30 [711 x 762]	32x 30 [813 x 762]	
Horizontal														
Air Coil Dimensions (H x W), in. [mm]	8 x 22 [203 x 559]	8 x 22 [203 x 559]	8 x 22 [203 x 559]	16 x 16 [406 x 406]	16 x 16 [406 x 406]	16 x 23 [406 x 584]	16 x 23 [406 x 584]	18 x 27 [457 x 686]	N/A	18 x 30 [457 x 762]	18 x 30 [457 x 762]	20 x 35 [508 x 889]	20 x 40 [508 x 1016]	
Air Coil Total Face Area, ft2 [m2]	1.22 [0.11]	1.22 [0.11]	1.22 [0.11]	1.8 [0.17]	1.8 [0.17]	2.6 [0.238]	2.6 [0.238]	2.9 [0.269]		3.8 [0.353]	3.8 [0.353]	4.9 [0.455]	5.6 [0.52]	
Air Coil Tube Size, in [mm]	3/8 [9.5]	3/8 [9.5]	3/8 [9.5]	3/8 [9.5]	3/8 [9.5]	3/8 [9.5]	3/8 [9.5]	3/8 [9.5]		3/8 [9.5]	3/8 [9.5]	3/8 [9.5]	3/8 [9.5]	
Air Coil Number of rows	3	3	3	3	3	3	3	3		3	3	3	3	
Filter Standard - 1" [25mm] MERV 4 Throwaway, in [mm]	11 x 25 [279 x 635]	11 x 25 [279 x 635]	11 x 25 [279 x 635]	16 x 20 [406 x 508]	16 x 20 [406 x 508]	16 x 25 [406 x 635]	16 x 25 [406 x 635]	2 - 18 x 14 [457 x 356]		1 - 18 x 18 [457 x 457] 1 - 18 x 14 [457 x 356]	1 - 18 x 18 [457 x 457] 1 - 18 x 14 [457 x 356]	2 - 18 x 20 [457 x 508]	1 - 20 x 22 [508 x 559] 1 - 20 x 20 [508 x 508]	
Filter Standard - 2" [51mm] Pleated MERV 13 Throwaway, in [mm]	11 x 25 [279 x 635]	11 x 25 [279 x 635]	11 x 25 [279 x 635]	16 x 20 [406 x 508]	16 x 20 [406 x 508]	16 x 25 [406 x 635]	16 x 25 [406 x 635]	18 x 29 [457 x 737]	18 x 32 [457 x 813]	18 x 32 [457 x 813]	20 x 37 [508 x 940]	1 - 20 x 22 [508 x 559] 1 - 20 x 20 [508 x 508]		

10/15/15

The manufacturer works continually to improve its products. As a result, the design and specifications of each product at the time of order may be changed without notice. Purchaser's approval of this data set signifies that the equipment is acceptable under the provisions of the job specification. Statements and other information contained herein are not express warranties and do not form the basis of any bargain between the parties, but are merely the manufacturer's opinion or commendation of its products.

Contractor: \_\_\_\_\_ P.O.: \_\_\_\_\_

Engineer: \_\_\_\_\_

Project Name: \_\_\_\_\_ Unit Tag: \_\_\_\_\_

**Arbor Base Series Commercial  
Geothermal/Water Source Heat Pumps  
0.5-6 Tons, 60Hz**



## Electrical Availability

### PSC

Voltage	Single Speed Models												
	006	009	012	015	018	024	030	036	041	042	048	060	070
115/60/1	•	•	•										
208-230/60/1	•	•	•	•	•	•	•	•	•	•	•	•	•
265/60/1	•	•	•	•	•	•	•	•					
208-230/60/3						•	•	•	•	•	•	•	•
460/60/3						•	•	•	•	•	•	•	•
575/60/3									•	•	•	•	•

10/15/15

### Variable Speed ECM

Voltage	Single Speed Models												
	006	009	012	015	018	024	030	036	041	042	048	060	070
208-230/60/1				•	•	•	•	•	•	•	•	•	•
265/60/1				•	•	•	•	•					
208-230/60/3						•	•	•	•	•	•	•	•
460/60/3						•	•	•	•	•	•	•	•
575/60/3													

10/15/15

### 5 Speed ECM

Voltage	Single Speed Models												
	006	009	012	015	018	024	030	036	041	042	048	060	070
208-230/60/1				•	•	•	•	•	•	•	•	•	•
265/60/1				•	•	•	•	•					
208-230/60/3						•	•	•	•	•	•	•	•
460/60/3						•	•	•	•	•	•	•	•
575/60/3													

10/15/15

The manufacturer works continually to improve its products. As a result, the design and specifications of each product at the time of order may be changed without notice. Purchaser's approval of this data set signifies that the equipment is acceptable under the provisions of the job specification. Statements and other information contained herein are not express warranties and do not form the basis of any bargain between the parties, but are merely the manufacturer's opinion or commendation of its products.

Contractor: \_\_\_\_\_ P.O.: \_\_\_\_\_

Engineer: \_\_\_\_\_

Project Name: \_\_\_\_\_ Unit Tag: \_\_\_\_\_

**Arbor Base Series Commercial  
Geothermal/Water Source Heat Pumps  
0.5-6 Tons, 60Hz**



## Electrical Data

### PSC Motor

Model	Rated Voltage	Voltage Min/Max	Compressor			Blower Motor FLA	Total Unit FLA	Min Circ Amp	Max Fuse/HACR Breaker
			MCC	RLA	LRA				
006	115/60/1	104/127	9.5	6.1	29.0	1.5	7.6	9.1	15
	208-230/60/1	187/253	4.7	3.0	15.0	0.6	3.6	4.4	10/15
	265/60/1	238/292	4.2	2.7	11.0	0.6	3.3	4.0	10/15
009	115/60/1	104/127	12.5	8.0	50.0	1.5	9.5	11.5	15
	208-230/60/1	187/253	6.4	4.1	21.0	0.6	4.7	5.7	10/15
	265/60/1	238/292	6.7	4.3	22.0	0.6	4.9	6.0	10/15
012	115/60/1	104/127	14.8	9.5	50.0	1.5	11	13.4	20
	208-230/60/1	187/253	7.7	4.9	25.0	0.6	5.5	6.7	10/15
	265/60/1	238/292	7.0	4.5	22.0	0.6	5.1	6.2	10/15
015	208-230/60/1	187/253	9.2	5.9	29.0	1.1	7.8	9.5	15
	265/60/1	238/292	7.8	5.0	28.0	1.0	6.6	8.0	10/15
018	208-230/60/1	187/253	10.4	6.7	33.5	1.1	7.8	9.5	15
	265/60/1	238/292	8.7	5.6	28.0	1.0	6.6	8.0	10/15
024	208-230/60/1	187/253	13.0	7.4	43.0	1.2	8.6	10.5	15
	265/60/1	238/292	12.6	6.7	46.0	1.1	7.8	9.5	15
	208-230/60/3	187/253	13.0	5.9	63.0	1.2	7.1	8.6	10/15
	460/60/3	414/506	6.0	2.9	30.0	0.6	3.5	4.2	10/15
030	208-230/60/1	187/253	17.5	9.4	54.0	1.5	10.9	13.3	20
	265/60/1	238/292	14.0	8.0	46.0	1.5	9.5	11.5	15
	208-230/60/3	187/253	13.5	6.6	63.0	1.5	8.1	9.8	15
	460/60/3	414/506	6.4	3.2	30.0	1.0	4.2	5.0	10/15
036	208-230/60/1	187/253	20.5	11.6	74.0	2.2	13.8	16.7	25
	265/60/1	238/292	17.7	9.9	67.0	1.1	11.0	13.5	20
	208-230/60/3	187/253	13.5	7.4	68.0	2.2	9.6	11.5	15
	460/60/3	414/506	7.1	3.8	34.0	1.1	4.9	5.9	10/15
041	208-230/60/1	187/253	25.0	13.0	88.0	3.5	16.5	19.8	30
	208-230/60/3	187/253	14.5	8.6	68.0	3.5	12.1	14.3	20
	460/60/3	414/506	7.7	4.2	34.0	1.8	6.0	7.1	10/15
	575/60/3	517/633	6.0	3.5	28.0	1.4	4.9	5.8	10/15
042	208-230/60/1	187/253	25.0	13.0	88.0	3.5	16.5	19.8	30
	208-230/60/3	187/253	14.5	8.6	68.0	3.5	12.1	14.3	20
	460/60/3	414/506	7.7	4.2	34.0	1.8	6.0	7.1	10/15
	575/60/3	517/633	6.0	3.5	28.0	1.4	4.9	5.8	10/15
048	208-230/60/1	187/253	24.5	15.7	84.0	3.5	19.2	23.1	35
	208-230/60/3	187/253	17.5	11.0	88.0	3.5	14.5	17.3	25
	460/60/3	414/506	8.0	5.6	44.0	1.8	7.4	8.8	10/15
	575/60/3	517/633	7.0	4.4	36.0	1.9	5.8	6.9	10/15
060	208-230/60/1	187/253	33.0	21.1	105.0	5.9	27.0	32.3	50
	208-230/60/3	187/253	22.0	12.9	88.0	5.9	18.8	22.0	30
	460/60/3	414/506	12.0	6.7	55.0	3.0	9.7	11.4	15
	575/60/3	517/633	7.5	5.1	36.0	1.9	7.0	8.3	10/15
070	208-230/60/1	187/253	36.0	23.0	130.0	5.9	28.9	34.7	50
	208-230/60/3	187/253	24.6	14.3	110.0	5.9	20.2	23.8	35
	460/60/3	414/506	11.5	7.1	55.0	3.0	10.1	11.9	15
	575/60/3	517/633	8.7	5.6	43.0	1.9	7.5	8.9	10/15

HACR circuit breaker in USA only

10/15/15

The manufacturer works continually to improve its products. As a result, the design and specifications of each product at the time of order may be changed without notice. Purchaser's approval of this data set signifies that the equipment is acceptable under the provisions of the job specification. Statements and other information contained herein are not express warranties and do not form the basis of any bargain between the parties, but are merely the manufacturer's opinion or commendation of its products.

Contractor: \_\_\_\_\_ P.O.: \_\_\_\_\_

Engineer: \_\_\_\_\_

Project Name: \_\_\_\_\_ Unit Tag: \_\_\_\_\_



## Electrical Data cont.

### 5 Speed ECM Motor

Model	Rated Voltage	Voltage Min/Max	Compressor			Blower Motor FLA	Total Unit FLA	Min Circ Amp	Max Fuse/HACR Breaker
			MCC	RLA	LRA				
015	208-230/60/1	187/253	9.2	5.9	29.0	4.1	10.0	11.5	15
	265/60/1	238/292	7.8	5.0	28.0	3.6	8.6	9.8	10/15
018	208-230/60/1	187/253	10.4	6.7	33.5	4.1	10.8	12.5	15
	265/60/1	238/292	8.7	5.6	28.0	3.6	9.2	10.6	10/15
024	208-230/60/1	187/253	13.0	7.4	43.0	4.1	11.5	13.4	20
	265/60/1	238/292	12.6	6.7	46.0	3.6	10.3	12.0	15
	208-230/60/3	187/253	13.0	5.9	63.0	4.1	10.0	11.5	15
	460/60/3	414/506	6.0	2.9	30.0	2.1	5.0	5.7	10/15
030	208-230/60/1	187/253	17.5	9.4	54.0	4.1	13.5	15.9	25
	265/60/1	238/292	14.0	8.0	46.0	3.6	11.6	13.6	20
	208-230/60/3	187/253	13.5	6.6	63.0	4.1	10.7	12.4	15
	460/60/3	414/506	6.4	3.2	30.0	2.1	5.3	6.1	10/15
036	208-230/60/1	187/253	20.5	11.6	74.0	4.1	15.7	18.6	30
	265/60/1	238/292	17.7	9.9	67.0	3.6	13.5	16.0	25
	208-230/60/3	187/253	13.5	7.4	68.0	4.1	11.5	13.4	20
	460/60/3	414/506	7.1	3.8	34.0	2.1	5.9	6.9	10/15
041	208-230/60/1	187/253	25.0	13.0	88.0	4.1	17.1	20.4	30
	208-230/60/3	187/253	14.5	8.6	68.0	4.1	12.7	14.9	20
	460/60/3	414/506	7.7	4.2	34.0	2.1	6.3	7.4	10/15
042	208-230/60/1	187/253	25.0	13.0	88.0	7.6	20.6	23.9	35
	208-230/60/3	187/253	14.5	8.6	68.0	7.6	16.2	18.4	25
	460/60/3	414/506	7.7	4.2	34.0	4.0	8.2	9.3	10/15
048	208-230/60/1	187/253	24.5	15.7	84.0	7.6	23.3	27.2	40
	208-230/60/3	187/253	17.5	11.0	88.0	7.6	18.6	21.4	30
	460/60/3	414/506	8.0	5.6	44.0	4.0	9.6	11.0	15
060	208-230/60/1	187/253	33.0	21.1	105.0	7.6	28.7	34.0	50
	208-230/60/3	187/253	22.0	12.9	88.0	7.6	20.5	23.7	35
	460/60/3	414/506	12.0	6.7	55.0	4.0	10.7	12.4	15
070	208-230/60/1	187/253	36.0	23.0	130.0	7.6	30.6	36.4	50
	208-230/60/3	187/253	24.6	14.3	110.0	7.6	21.9	25.5	35
	460/60/3	414/506	11.5	7.1	55.0	4.0	11.1	12.9	20

The manufacturer works continually to improve its products. As a result, the design and specifications of each product at the time of order may be changed without notice. Purchaser's approval of this data set signifies that the equipment is acceptable under the provisions of the job specification. Statements and other information contained herein are not express warranties and do not form the basis of any bargain between the parties, but are merely the manufacturer's opinion or commendation of its products.

Contractor: \_\_\_\_\_ P.O.: \_\_\_\_\_

Engineer: \_\_\_\_\_

Project Name: \_\_\_\_\_ Unit Tag: \_\_\_\_\_



## Electrical Data cont.

### Variable Speed ECM Motor

Model	Rated Voltage	Voltage Min/Max	Compressor			Blower Motor FLA	Total Unit FLA	Min Circ Amp	Max Fuse/HACR Breaker
			MCC	RLA	LRA				
015	208-230/60/1	187/253	9.2	5.9	29.0	4.0	9.9	11.4	15
	265/60/1	238/292	7.8	5.0	28.0	4.1	9.1	10.3	15
018	208-230/60/1	187/253	10.4	6.7	33.5	4.0	10.7	12.4	15
	265/60/1	238/292	8.7	5.6	28.0	4.1	9.7	11.1	15
024	208-230/60/1	187/253	13.0	7.4	43.0	4.0	11.4	13.3	20
	265/60/1	238/292	12.6	6.7	46.0	4.1	10.8	12.5	20
	208-230/60/3	187/253	13.0	5.9	63.0	4.0	9.9	11.4	15
	460/60/3	414/506	6.0	2.9	30.0	4.1	7.0	7.7	10/15
030	208-230/60/1	187/253	17.5	9.4	54.0	4.0	13.4	15.8	25
	265/60/1	238/292	14.0	8.0	46.0	4.1	12.1	14.1	20
	208-230/60/3	187/253	13.5	6.6	63.0	4.0	10.6	12.3	20
	460/60/3	414/506	6.4	3.2	30.0	4.1	7.3	8.1	10/15
036	208-230/60/1	187/253	20.5	11.6	74.0	4.0	15.6	18.5	30
	265/60/1	238/292	17.7	9.9	67.0	4.1	14.0	16.5	25
	208-230/60/3	187/253	13.5	7.4	68.0	4.0	11.4	13.3	20
	460/60/3	414/506	7.1	3.8	34.0	4.1	7.9	8.9	15
041	208-230/60/1	187/253	25.0	13.0	88.0	4.0	17.0	20.3	35
	208-230/60/3	187/253	14.5	8.6	68.0	4.0	12.6	14.8	25
	460/60/3	414/506	7.7	4.2	34.0	4.1	8.3	9.4	15
042	208-230/60/1	187/253	25.0	13.0	88.0	4.0	17.0	20.3	35
	208-230/60/3	187/253	14.5	8.6	68.0	4.0	12.6	14.8	25
	460/60/3	414/506	7.7	4.2	34.0	4.1	8.3	9.4	15
048	208-230/60/1	187/253	24.5	15.7	84.0	4.0	19.7	23.6	40
	208-230/60/3	187/253	17.5	11.0	88.0	4.0	15.0	17.8	30
	460/60/3	414/506	8.0	5.6	44.0	4.1	9.7	11.1	15
060	208-230/60/1	187/253	33.0	21.1	105.0	7.0	28.1	33.4	55
	208-230/60/3	187/253	22.0	12.9	88.0	7.0	19.9	23.1	35
	460/60/3	414/506	12.0	6.7	55.0	6.9	13.6	15.3	25
070	208-230/60/1	187/253	36.0	23.0	130.0	7.0	30.0	35.8	60
	208-230/60/3	187/253	24.6	14.3	110.0	7.0	21.3	24.9	40
	460/60/3	414/506	11.5	7.1	55.0	6.9	14.0	15.8	25

HACR circuit breaker in USA only

10/15/15



**CAUTION:** When installing a unit with an variable speed ECM blower motor in 460/60/3 voltage, a neutral wire is required to allow proper unit operation.

Contractor: \_\_\_\_\_ P.O.: \_\_\_\_\_

Engineer: \_\_\_\_\_

Project Name: \_\_\_\_\_ Unit Tag: \_\_\_\_\_



## Blower Performance Data

### Standard PSC Motor

Model	Blower Spd	Blower Size	Motor HP	Airflow (cfm) at External Static Pressure (in. wg)																
				0	0.05	0.10	0.15	0.20	0.25	0.30	0.35	0.40	0.45	0.50	0.60	0.70	0.80	0.90	1.00	
006	H	6 x 8	1/10	435	425	415	405	390	365	340	325	305	290	275	245	-	-	-	-	
	MH			400	390	380	370	355	335	310	295	280	265	255	210	195	-	-	-	-
	ML*			365	355	345	335	315	300	280	270	255	240	230	195	-	-	-	-	-
	L			320	305	295	280	260	250	235	225	210	195	180	150	135	-	-	-	-
009	H	6 x 8	1/10	435	423	415	405	390	370	340	325	305	290	275	245	-	-	-	-	
	MH			400	388	380	370	355	335	310	295	280	265	255	210	195	-	-	-	-
	ML*			365	353	345	335	315	300	280	270	255	240	230	195	-	-	-	-	-
	L			320	305	295	280	260	250	235	225	210	195	180	150	135	-	-	-	-
012	H	6 x 8	1/10	435	423	415	405	390	370	340	325	305	290	275	245	-	-	-	-	
	MH			400	388	380	370	355	335	310	295	280	265	255	210	195	-	-	-	-
	ML*			365	353	345	335	315	300	280	270	255	240	230	195	-	-	-	-	-
	L			320	305	295	280	260	250	235	225	210	195	180	150	135	-	-	-	-
015	H	9 x 7	1/6	795	775	755	735	715	690	670	600	530	490	455	395	-	-	-	-	
	M			725	710	695	675	660	640	620	560	495	465	435	375	-	-	-	-	
	L			620	610	600	590	575	550	525	490	455	395	340	290	-	-	-	-	-
018	H	9 x 7	1/6	795	775	755	735	715	690	670	600	530	490	455	395	-	-	-	-	
	M			725	710	695	675	660	640	620	560	495	465	435	375	-	-	-	-	
	L			620	610	600	590	575	550	525	490	455	395	340	290	-	-	-	-	-
024	H	9 x 7	1/5	1035	1015	995	970	950	925	900	865	835	795	760	685	560	-	-	-	
	M			880	860	845	820	805	785	765	740	720	690	665	590	530	-	-	-	-
	L			810	790	775	755	740	725	705	675	650	620	595	510	-	-	-	-	-
030	H	9 x 7	1/3	1170	1145	1130	1110	1080	1050	1030	995	965	925	890	815	700	-	-	-	
	M			1040	1030	1020	1005	990	965	945	915	890	860	830	760	650	-	-	-	-
	L			825	820	815	810	805	795	790	775	765	735	705	655	-	-	-	-	-
036	H	9 x 7	1/2	1320	1295	1275	1240	1210	1185	1155	1120	1085	1045	1005	915	805	655	-	-	
	M			1180	1155	1140	1125	1100	1075	1055	1020	990	955	920	840	725	590	-	-	-
	L			1045	1035	1025	1015	1005	985	970	945	920	890	865	795	690	-	-	-	-
041	H	9 x 7	1/3	1140	1115	1090	1060	1030	1000	975	940	905	865	830	750	353	-	-	-	
	M			1025	1000	980	955	935	910	885	850	820	780	745	670	475	-	-	-	-
	L			935	920	905	885	865	845	825	795	770	740	710	565	-	-	-	-	-
042	H	10x10	1/2	1530	1500	1475	1445	1425	1380	1340	1290	1240	1185	1130	810	715	630	-	-	
	M			1435	1415	1395	1370	1350	1325	1300	1265	1235	1180	1130	1040	755	640	-	-	-
	L			1160	1140	1130	1120	1100	1070	1050	1020	990	950	910	831	632	590	-	-	-
048	H	10 x 10	1/2	1845	1810	1775	1740	1705	1660	1615	1560	1510	1455	1405	1275	1080	-	-	-	-
	M			1655	1620	1585	1555	1535	1500	1465	1415	1370	1330	1290	1170	970	-	-	-	-
	L			1325	1315	1310	1285	1265	1245	1220	1180	1140	1115	1090	990	-	-	-	-	-
060	H	11 x 10	1	2345	2320	2305	2285	2250	2205	2180	2135	2090	2060	2030	1945	1850	1740	1600	1465	
	M			2195	2170	2150	2125	2105	2075	2045	2005	1970	1940	1915	1845	1770	1630	1500	-	
	L			2045	2030	2020	1995	1980	1950	1925	1890	1855	1825	1800	1750	1640	1535	1395	-	-
070	H	11 x 10	1	2505	2475	2450	2410	2385	2365	2340	2305	2275	2250	2230	2170	2070	1975	1880	1765	
	M			2290	2265	2250	2230	2200	2170	2150	2135	2125	2105	2085	2015	1950	1865	1785	1680	
	L			2115	2100	2085	2060	2040	2020	2005	1990	1975	1950	1930	1875	1805	1720	1655	1510	-

**Factory settings are in Bold**

Airflow values are with dry coil and standard filter

For wet coil performance first calculate the face velocity of the air coil (Face Velocity [fpm] = Airflow [cfm] / Face Area [sq ft]).

Then for velocities of 200 fpm reduce the static capability by 0.03 in. wg, 300 fpm by 0.08 in. wg, 400 fpm by 0.12 in. wg. and 500 fpm by 0.16 in. wg.

\* Setting for 265V operation.

10/15/15

The manufacturer works continually to improve its products. As a result, the design and specifications of each product at the time of order may be changed without notice. Purchaser's approval of this data set signifies that the equipment is acceptable under the provisions of the job specification. Statements and other information contained herein are not express warranties and do not form the basis of any bargain between the parties, but are merely the manufacturer's opinion or commendation of its products.

Contractor: \_\_\_\_\_ P.O.: \_\_\_\_\_

Engineer: \_\_\_\_\_

Project Name: \_\_\_\_\_ Unit Tag: \_\_\_\_\_



## Blower Performance Data cont.

### 5- Speed ECM Motor

Model	Motor Spd	Motor Tap	Blower Size	Motor HP	Airflow (cfm) at External Static Pressure (in. wg)															
					0	0.05	0.10	0.15	0.20	0.25	0.30	0.35	0.40	0.45	0.50	0.60	0.70	0.80	0.90	1.00
015	High	5	9 x 7	1/2	915	895	880	865	850	830	815	805	795	775	750	730	695	640	-	-
	Med High	4			805	785	765	750	740	725	705	685	665	655	635	605	535	-	-	-
	Med	3			725	715	700	680	660	635	615	600	585	560	535	485	-	-	-	-
	Med Low	2			695	675	650	630	610	590	575	550	525	490	455	-	-	-	-	-
	Low	1			655	600	550	530	508	490	475	435	395	350	-	-	-	-	-	-
018	High	5	9 x 7	1/2	915	895	880	865	850	830	815	805	795	775	750	730	695	640	-	-
	Med High	4			805	785	765	750	740	725	705	685	665	655	635	605	535	-	-	-
	Med	3			725	715	700	680	660	635	615	600	585	560	535	485	-	-	-	-
	Med Low	2			695	675	650	630	610	590	575	550	525	490	455	-	-	-	-	-
	Low	1			655	600	550	530	508	490	475	435	395	350	-	-	-	-	-	-
024	High	5	9 x 7	1/2	1000	983	965	950	935	923	910	900	890	873	855	800	725	-	-	-
	Med High	4			905	888	870	860	850	833	815	805	795	775	755	740	705	-	-	-
	Med	3			855	838	820	800	780	773	765	745	725	715	705	670	580	-	-	-
	Med Low	2			790	773	755	743	730	710	690	675	660	643	625	570	-	-	-	-
	Low	1			615	600	585	565	545	523	500	468	435	408	380	-	-	-	-	-
030	High	5	9 x 7	1/2	1315	1293	1270	1243	1215	1183	1150	1120	1090	1055	1020	930	845	-	-	-
	Med High	4			1145	1130	1115	1105	1095	1080	1065	1053	1040	1013	985	905	820	-	-	-
	Med	3			1020	1008	995	978	960	950	940	923	905	895	885	850	795	735	-	-
	Med Low	2			980	963	945	935	925	908	890	878	865	848	830	805	780	720	-	-
	Low	1			795	778	760	738	715	705	695	678	660	650	640	575	530	-	-	-
036	High	5	9 x 7	1/2	1405	1380	1355	1333	1310	1275	1240	1208	1175	1135	1095	1015	895	775	-	-
	Med High	4			1275	1265	1255	1245	1235	1215	1195	1168	1140	1105	1070	985	875	770	-	-
	Med	3			1180	1163	1145	1135	1125	1110	1095	1085	1075	1060	1045	975	865	750	-	-
	Med Low	2			1125	1115	1105	1090	1075	1065	1055	1040	1025	1008	990	950	855	730	-	-
	Low	1			835	823	810	793	775	758	740	723	705	690	675	640	570	-	-	-
041	High	5	9 x 7	1/2	1285	1250	1215	1180	1150	1115	1085	1055	1025	980	940	875	600	510	-	-
	Med High	4			1225	1195	1170	1140	1115	1085	1045	1020	995	955	920	855	585	495	-	-
	Med	3			1120	1100	1085	1070	1055	1040	1030	995	960	925	890	840	560	475	-	-
	Med Low	2			1075	1060	1045	1025	1005	995	985	965	945	905	860	825	545	465	-	-
	Low	1			795	770	750	730	710	700	690	665	645	615	585	545	510	455	-	-
042	High	5	11 x 10	1	1805	1793	1780	1770	1760	1740	1720	1710	1700	1688	1675	1655	1635	1590	1550	1475
	Med High	4			1695	1688	1680	1660	1640	1623	1605	1593	1580	1573	1565	1535	1505	1460	1395	1300
	Med	3			1605	1593	1580	1560	1540	1523	1505	1493	1480	1470	1460	1420	1380	1305	1205	1135
	Med Low	2			1510	1495	1480	1465	1450	1435	1420	1403	1385	1373	1360	1310	1250	1135	1055	1010
	Low	1			1340	1323	1305	1283	1260	1245	1230	1213	1195	1175	1155	1040	915	875	-	-
048	High	5	11 x 10	1	2000	1990	1980	1968	1955	1940	1925	1920	1915	1910	1905	1880	1845	1790	1655	1505
	Med High	4			1840	1833	1825	1810	1795	1785	1775	1770	1765	1755	1745	1715	1670	1620	1540	1360
	Med	3			1755	1743	1730	1718	1705	1698	1690	1683	1675	1655	1635	1600	1555	1495	1435	1300
	Med Low	2			1645	1630	1615	1605	1595	1583	1570	1560	1550	1530	1510	1475	1420	1350	1265	1180
	Low	1			1430	1413	1395	1385	1375	1358	1340	1320	1300	1275	1250	1170	1060	995	930	875
060	High	5	11 x 10	1	2455	2440	2425	2413	2400	2390	2380	2365	2350	2335	2320	2295	2245	2175	2085	2015
	Med High	4			2260	2250	2240	2223	2205	2195	2185	2168	2150	2133	2115	2085	2045	2005	1975	1930
	Med	3			2140	2123	2105	2095	2085	2065	2045	2033	2020	2005	1990	1960	1915	1870	1835	1790
	Med Low	2			2010	1995	1980	1963	1945	1935	1925	1908	1890	1873	1855	1825	1780	1745	1690	1645
	Low	1			1815	1803	1790	1775	1760	1743	1725	1705	1685	1665	1645	1600	1565	1515	1470	1410
070	High	5	11 x 10	1	2500	2495	2490	2473	2455	2438	2420	2405	2390	2363	2335	2325	2280	2215	2120	1995
	Med High	4			2300	2295	2290	2270	2250	2233	2215	2200	2185	2168	2150	2115	2080	2040	1990	1915
	Med	3			2175	2163	2150	2138	2125	2100	2075	2060	2045	2030	2015	1980	1945	1905	1860	1820
	Med Low	2			2040	2028	2015	2000	1985	1965	1945	1930	1915	1898	1880	1850	1805	1760	1725	1685
	Low	1			1850	1833	1815	1800	1785	1765	1745	1728	1710	1683	1655	1615	1580	1530	1475	1300

Factory settings are in Bold  
Air flow values are with dry coil and standard 1" filter

### 5-Speed ECM Motor Connections

10/15/15

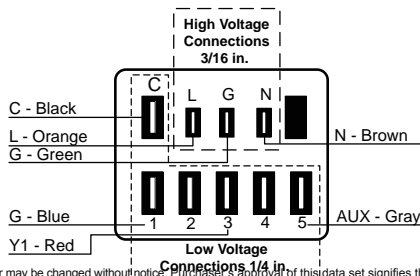

The manufacturer works continually to improve its products. As a result, the design and specifications of each product at the time of order may be changed without notice. This data set signifies that the equipment is acceptable under the provisions of the job specification. Statements and other information contained herein are not express warranties and do not form the basis of any bargain between the parties, but are merely the manufacturer's opinion or commendation of its products.

Contractor: \_\_\_\_\_ P.O.: \_\_\_\_\_

Engineer: \_\_\_\_\_

Project Name: \_\_\_\_\_ Unit Tag: \_\_\_\_\_

**Arbor Base Series Commercial  
Geothermal/Water Source Heat Pumps  
0.5-6 Tons, 60Hz**



## Blower Performance Data cont.

### Variable Speed ECM Motor

Model	Max ESP	Blower Size	Motor hp	Air Flow Dip Switch Settings											
				1	2	3	4	5	6	7	8	9	10	11	12
015	0.50	9 x 7	1/2	300	400 L	<b>500</b>	<b>600</b> M	<b>700</b> H	<b>800</b>						
018	0.50	9 x 7	1/2	300	400 L	<b>500</b>	<b>600</b> M	<b>700</b> H	<b>800</b>						
024	0.50	9 x 7	1/2		400 L	500	600 M	<b>700</b> H	<b>800</b>	<b>900</b>	<b>1000</b>	<b>1100</b>			
030	0.50	9 x 7	1/2		400	500 L	600	<b>700</b> M	<b>800</b>	<b>900</b>	<b>1000</b> H	<b>1100</b>			
036	0.50	9 x 7	1/2		400	500	600 L	700	<b>800</b>	<b>900</b> M	<b>1000</b>	<b>1100</b> H	<b>1200</b>		
041	0.50	9 x 7	1/2		400	500	600	700 L	875	<b>1050</b> M	<b>1150</b>	<b>1250</b> H	<b>1325</b>	<b>1375</b>	
042	0.50	11 x 10	1/2	500	600	700 L	875	<b>1050</b> M	<b>1150</b>	<b>1250</b>	<b>1325</b>	<b>1375</b> H	<b>1475</b>	<b>1550</b>	
048	0.50	11 x 10	1/2	500	600	700	875 L	1050	1150	<b>1250</b>	<b>1325</b> M	<b>1375</b>	<b>1475</b>	<b>1550</b> H	<b>1600</b>
060	0.75	11 x 10	1	600	800	1000 L	1300	<b>1500</b> M	<b>1750</b>	<b>1950</b> H	<b>2100</b>	<b>2200</b>	<b>2300</b>		
070	0.75	11 x 10	1	600	800	1000 L	1300	<b>1500</b> M	<b>1750</b>	<b>1950</b>	<b>2100</b> H	<b>2200</b>	<b>2300</b>		

Factory settings are at recommended L-M-H DIP switch locations

10/15/15

CFM is controlled within ±5% up to the maximum ESP

M-H settings MUST be located within boldface CFM range

Max ESP includes allowance for wet coil and standard filter

Lowest and Highest DIP switch settings are assumed to be L and H respectively



Contractor: \_\_\_\_\_ P.O.: \_\_\_\_\_

Engineer: \_\_\_\_\_

Project Name: \_\_\_\_\_ Unit Tag: \_\_\_\_\_



## Operating Limits

Operating Limits	Cooling		Heating	
	(°F)	(°C)	(°F)	(°C)
<b>Air Limits</b>				
Min. Ambient Air	45	7.2	45	7.2
Rated Ambient Air	80	26.7	70	21.1
Max. Ambient Air	100	37.8	85	29.4
Min. Entering Air	50	10.0	40	4.4
Rated Entering Air db/wb	80.6/66.2	27/19	68	20.0
Max. Entering Air db/wb	110/83	43/28.3	80	26.7
<b>Water Limits</b>				
Min. Entering Water	30	-1.1	20	-6.7
Normal Entering Water	50-110	10-43.3	30-70	-1.1
Max. Entering Water	120	48.9	90	32.2

**NOTE:** Minimum/maximum limits are only for start-up conditions, and are meant for bringing the space up to occupancy temperature. Units are not designed to operate at the minimum/maximum conditions on a regular basis. The operating limits are dependent upon three primary factors: 1) water temperature, 2) return air temperature, and 3) ambient temperature. When any of the factors are at the minimum or maximum levels, the other two factors must be at the normal level for proper and reliable unit operation.

## Definitions

### ABBREVIATIONS AND DEFINITIONS:

cfm = airflow, cubic feet/minute	HE = total heat of extraction, MBtu/h
EWT = entering water temperature, Fahrenheit	HWC = hot water generator capacity, MBtu/h
gpm = water flow in gallons/minute	EER = Energy Efficient Ratio
WPD = water pressure drop, psi and feet of water	= BTU output/Watt input
EAT = entering air temperature, Fahrenheit	COP = Coefficient of Performance
(dry bulb/wet bulb)	= Btu output/Btu input
HC = air heating capacity, MBtu/h	LWT = leaving water temperature, °F
TC = total cooling capacity, MBtu/h	LAT = leaving air temperature, °F
SC = sensible cooling capacity, MBtu/h	TH = total heating capacity, MBtu/h
KW = total power unit input, kilowatts	LC = latent cooling capacity, MBtu/h
HR = total heat of rejection, MBtu/h	S/T = sensible to total cooling ratio

Contractor: \_\_\_\_\_ P.O.: \_\_\_\_\_

Engineer: \_\_\_\_\_

Project Name: \_\_\_\_\_ Unit Tag: \_\_\_\_\_



## Correction Factor Tables

### Cooling Capacity Corrections

Entering Air WB °F	Total Clg Cap	Sensible Cooling Capacity Multipliers - Entering DB °F										Power Input	Heat of Rejection
		60	65	70	75	80	80.6	85	90	95	100		
55	0.898	0.723	0.866	1.048	1.185	*	*	*	*	*	*	0.985	0.913
60	0.912		0.632	0.880	1.078	1.244	1.260	*	*	*	*	0.994	0.927
65	0.967			0.694	0.881	1.079	1.085	1.270	*	*	*	0.997	0.972
66.2	0.983			0.655	0.842	1.040	1.060	1.232	*	*	*	0.999	0.986
<b>67</b>	<b>1.000</b>			0.616	0.806	<b>1.000</b>	1.023	1.193	1.330	*	*	<b>1.000</b>	<b>1.000</b>
70	1.053				0.693	0.879	0.900	1.075	1.250	1.404	*	1.003	1.044
75	1.168					0.687	0.715	0.875	1.040	1.261	1.476	1.007	1.141

NOTE: \* Sensible capacity equals total capacity at conditions shown.

11/10/09

### Heating Corrections

Ent Air DB °F	Htg Cap	Power	Heat of Ext
45	1.062	0.739	1.158
50	1.050	0.790	1.130
55	1.037	0.842	1.096
60	1.025	0.893	1.064
65	1.012	0.945	1.030
68	1.005	0.976	1.012
<b>70</b>	<b>1.000</b>	<b>1.000</b>	<b>1.000</b>
75	0.987	1.048	0.970
80	0.975	1.099	0.930

11/10/09

### Airflow Corrections

Airflow		Cooling				Heating		
cfm Per Ton of Clg	% of Nominal	Total Cap	Sens Cap	Power	Heat of Rej	Htg Cap	Power	Heat of Ext
240	60	0.922	0.786	0.910	0.920	0.943	1.150	0.893
275	69	0.944	0.827	0.924	0.940	0.958	1.105	0.922
300	75	0.959	0.860	0.937	0.955	0.968	1.078	0.942
325	81	0.971	0.894	0.950	0.967	0.977	1.053	0.959
350	88	0.982	0.929	0.964	0.978	0.985	1.031	0.973
375	94	0.992	0.965	0.982	0.990	0.993	1.014	0.988
<b>400</b>	<b>100</b>	<b>1.000</b>	<b>1.000</b>	<b>1.000</b>	<b>1.000</b>	<b>1.000</b>	<b>1.000</b>	<b>1.000</b>
425	106	1.007	1.034	1.020	1.010	1.007	0.990	1.011
450	113	1.012	1.065	1.042	1.018	1.013	0.983	1.020
475	119	1.017	1.093	1.066	1.026	1.018	0.980	1.028
500	125	1.019	1.117	1.092	1.033	1.023	0.978	1.034
520	130	1.020	1.132	1.113	1.038	1.026	0.975	1.038

11/10/09

The manufacturer works continually to improve its products. As a result, the design and specifications of each product at the time of order may be changed without notice. Purchaser's approval of this data set signifies that the equipment is acceptable under the provisions of the job specification. Statements and other information contained herein are not express warranties and do not form the basis of any bargain between the parties, but are merely the manufacturer's opinion or commendation of its products.

Contractor: \_\_\_\_\_ P.O.: \_\_\_\_\_

Engineer: \_\_\_\_\_

Project Name: \_\_\_\_\_ Unit Tag: \_\_\_\_\_



## Antifreeze Corrections

Catalog performance can be corrected for antifreeze use. Please use the following table and note the example given.

Antifreeze Type	Antifreeze % by wt	Cooling Capacity	Heating Capacity	Pressure Drop
EWT - degF [DegC]		90 [32.2]	30 [-1.1]	30 [-1.1]
Water	0	1.000	1.000	1.000
Ethylene Glycol	10	0.991	0.973	1.075
	20	0.979	0.943	1.163
	30	0.965	0.917	1.225
	40	0.955	0.890	1.324
	50	0.943	0.865	1.419
Propylene Glycol	10	0.981	0.958	1.130
	20	0.969	0.913	1.270
	30	0.950	0.854	1.433
	40	0.937	0.813	1.614
	50	0.922	0.770	1.816
Ethanol	10	0.991	0.927	1.242
	20	0.972	0.887	1.343
	30	0.947	0.856	1.383
	40	0.930	0.815	1.523
	50	0.911	0.779	1.639
Methanol	10	0.986	0.957	1.127
	20	0.970	0.924	1.197
	30	0.951	0.895	1.235
	40	0.936	0.863	1.323
	50	0.920	0.833	1.399

**Warning:** Gray area represents antifreeze concentrations greater than 35% by weight and should be avoided due to the extreme performance penalty they represent.

### Antifreeze Correction Example

Antifreeze solution is Propylene Glycol 20% by weight. Determine the corrected heating and cooling performance at 30°F and 90°F respectively as well as pressure drop at 30°F for a Model 024-PSC.

The corrected cooling capacity at 90°F would be: 22,600 Btu/h x 0.969 = 21,899 Btu/h

The corrected heating capacity at 30°F would be: 16,800 Btu/h x 0.913 = 15,338 Btu/h

The corrected pressure drop at 30°F and 6 gpm would be: 20.8 ft. hd x 1.270 = 26.42 ft. hd.

Contractor: \_\_\_\_\_ P.O.: \_\_\_\_\_

Engineer: \_\_\_\_\_

Project Name: \_\_\_\_\_ Unit Tag: \_\_\_\_\_



# Pressure Drop

Model	GPM	Pressure Drop (psi)				
		30°F	50°F	70°F	90°F	110°F
006	1.0	1.2	1.2	1.1	1.0	1.0
	1.5	2.2	2.0	1.9	1.8	1.7
	2.0	3.3	3.1	2.9	2.7	2.5
	2.5	4.1	3.8	3.4	3.1	2.9
009	1.5	1.9	1.7	1.5	1.3	1.1
	2.0	3.0	2.8	2.6	2.4	2.2
	3.0	6.3	6.3	6.1	5.9	5.7
	4.0	8.1	7.9	7.4	6.8	6.1
012	1.5	1.1	1.1	1.0	0.9	0.9
	2.5	2.4	2.3	2.2	2.0	1.9
	3.5	4.2	4.0	3.7	3.4	3.2
	4.5	6.1	5.9	5.2	4.7	4.1
015	2.0	1.8	1.7	1.6	1.4	1.2
	3.0	3.3	3.1	2.9	2.6	2.3
	4.0	5.0	4.9	4.8	4.7	4.6
	5.0	7.1	6.7	5.9	5.4	5.1
018	3.0	3.3	3.2	3.0	2.8	2.6
	4.0	4.7	4.2	3.9	3.6	3.1
	5.0	6.2	5.2	4.7	4.1	3.5
	6.0	7.7	6.2	5.4	4.6	3.8
024	3.0	3.2	3.1	2.9	2.7	2.5
	4.5	6.1	5.5	4.9	4.5	4.2
	6.0	9.0	7.9	6.9	6.3	5.8
	8.0	12.9	10.9	9.5	8.8	7.9
030	4.0	2.4	2.3	2.2	2.0	1.8
	6.0	5.1	4.9	4.7	4.5	4.3
	8.0	7.8	7.5	7.1	6.9	6.7
	10.0	10.5	10.1	9.6	9.3	8.9
036	5.0	2.0	1.9	1.7	1.5	1.4
	7.0	3.6	3.5	3.3	3.1	2.9
	9.0	5.2	5.1	4.8	4.6	4.4
	12.0	7.5	7.4	7.1	6.9	6.7
041	5.0	1.5	1.2	0.9	0.5	0.4
	8.0	3.4	3.1	2.8	2.5	2.1
	11.0	7.9	7.5	7.2	6.9	6.6
	14.0	9.1	8.8	8.5	8.2	7.9
042	5.0	2.1	2.0	1.8	1.6	1.4
	8.0	4.8	4.7	4.5	4.4	4.2
	11.0	7.5	7.4	7.0	6.6	6.1
	14.0	10.1	9.9	9.6	8.8	8.1
048	6.0	2.7	2.6	2.4	2.2	2.0
	9.0	6.0	5.9	5.4	5.2	5.1
	12.0	9.5	9.3	8.5	8.3	8.1
	16.0	14.2	13.9	12.7	12.3	12.1
060	9.0	4.5	4.4	4.2	4.0	3.8
	12.0	6.5	6.3	6.1	5.9	5.7
	15.0	8.6	8.1	7.9	7.7	7.5
	20.0	12.1	11.2	10.8	10.6	10.4
070	12.0	5.7	5.6	5.4	5.2	5.0
	15.0	8.9	8.6	8.2	7.7	6.7
	18.0	12.0	11.5	11.0	10.1	8.4
	24.0	17.4	16.9	16.5	15.1	11.8

10/15/15

Valve	GPM	Cv	Pressure Drop (psi)
Internally mounted 2-position solenoid water valves are not available on models 006-012			
1/2"	3.0	9.9	0.09
	4.0	10.1	0.16
	5.0	10.4	0.23
	6.0	10.6	0.32
1/2"	3.0	9.9	0.09
	4.0	10.1	0.16
	5.0	10.4	0.23
	6.0	10.6	0.32
3/4"	3.0	9.9	0.09
	4.5	10.2	0.19
	6.0	10.6	0.32
	8.0	11.0	0.53
3/4"	4.0	10.1	0.16
	6.0	10.6	0.32
	8.0	11.0	0.53
	10.0	11.5	0.76
3/4"	5.0	10.4	0.23
	7.0	10.8	0.42
	9.0	11.2	0.64
	12.0	11.9	1.02
N/A			
3/4"	5.0	10.4	0.23
	8.0	11.0	0.53
	11.0	11.7	0.89
	14.0	12.3	1.29
3/4"	6.0	10.6	0.32
	9.0	11.2	0.64
	12.0	11.9	1.02
	16.0	12.8	1.57
1"	9.0	16.8	0.29
	12.0	17.4	0.47
	15.0	18.1	0.69
	20.0	19.2	1.09
1"	12.0	17.4	0.47
	15.0	18.1	0.69
	18.0	18.7	0.92
	24.0	20.1	1.43

10/15/15

The manufacturer works continually to improve its products. As a result, the design and specifications of each product at the time of order may be changed without notice. Purchaser's approval of this data set signifies that the equipment is acceptable under the provisions of the job specification. Statements and other information contained herein are not express warranties and do not form the basis of any bargain between the parties, but are merely the manufacturer's opinion or commendation of its products.

Contractor: \_\_\_\_\_ P.O.: \_\_\_\_\_

Engineer: \_\_\_\_\_

Project Name: \_\_\_\_\_ Unit Tag: \_\_\_\_\_



## ZB006 - Performance Data

### Single Speed with PSC (250 CFM)

EWT °F	Flow GPM	WPD		HEATING - EAT 70°F					COOLING - EAT 80/67°F					
		psi	ft	HC MBtu/h	Power kW	HE MBtu/h	LAT °F	COP	TC MBtu/h	SC MBtu/h	S/T Ratio	Power kW	HR MBtu/h	EER
20	1.0	1.3	3.0	Operation not recommended					Operation not recommended					
	1.5	2.2	5.1											
	2.0	3.4	7.9	4.2	0.54	2.3	83.4	2.25						
30	1.0	1.2	2.8	Operation not recommended					Operation not recommended					
	1.5	2.2	5.1	5.6	0.59	3.6	88.9	2.78	8.5	5.2	0.61	0.38	9.8	22.4
	2.0	3.3	7.6	5.0	0.56	3.1	86.5	2.60	8.6	5.3	0.61	0.36	9.8	24.2
40	1.0	1.2	2.8	Operation not recommended					Operation not recommended					
	1.5	2.1	4.9	6.2	0.60	4.1	91.0	3.01	8.6	5.3	0.62	0.40	10.0	21.4
	2.0	3.2	7.4	6.0	0.59	4.0	90.1	2.98	8.7	5.4	0.62	0.39	10.0	22.4
50	1.0	1.2	2.8	6.7	0.62	4.6	92.8	3.17	8.7	5.4	0.63	0.44	10.2	19.9
	1.5	2.0	4.6	6.8	0.61	4.7	93.2	3.25	8.7	5.5	0.63	0.43	10.1	20.4
	2.0	3.1	7.2	6.9	0.61	4.8	93.6	3.33	8.7	5.5	0.63	0.42	10.1	20.9
60	1.0	1.1	2.5	7.4	0.63	5.3	95.4	3.47	8.0	5.2	0.64	0.48	9.7	16.8
	1.5	2.0	4.6	7.5	0.62	5.4	95.9	3.53	8.1	5.2	0.65	0.47	9.7	17.2
	2.0	3.0	6.9	7.6	0.62	5.5	96.3	3.59	8.2	5.3	0.65	0.46	9.7	17.7
70	1.0	1.1	2.5	8.1	0.63	6.0	98.0	3.77	7.4	4.9	0.66	0.52	9.2	14.2
	1.5	1.9	4.3	8.2	0.64	6.1	98.5	3.80	7.5	5.0	0.66	0.51	9.3	14.6
	2.0	2.9	6.7	8.4	0.64	6.2	99.0	3.83	7.6	5.0	0.66	0.50	9.3	15.1
80	1.0	1.1	2.5	8.9	0.64	6.7	101.1	4.08	7.0	4.7	0.67	0.60	9.1	11.7
	1.5	1.8	4.2	9.1	0.65	6.9	101.6	4.10	7.1	4.8	0.67	0.57	9.1	12.4
	2.0	2.8	6.5	9.2	0.65	7.0	102.1	4.13	7.2	4.9	0.67	0.56	9.1	13.0
90	1.0	1.0	2.3	9.8	0.65	7.5	104.2	4.39	6.6	4.5	0.68	0.66	8.9	10.1
	1.5	1.8	4.2	9.9	0.66	7.7	104.7	4.40	6.7	4.6	0.68	0.63	8.9	10.7
	2.0	2.7	6.2	10.1	0.67	7.8	105.3	4.41	6.9	4.7	0.68	0.61	9.0	11.3
100	1.0	1.0	2.3	Operation not recommended					Operation not recommended					
	1.5	1.7	3.9						6.2	4.4	0.71	0.69	8.6	9.0
	2.0	2.6	6.0						6.3	4.4	0.70	0.67	8.6	9.5
110	1.0	1.0	2.3	Operation not recommended					Operation not recommended					
	1.5	1.7	3.9						5.7	4.2	0.73	0.75	8.2	7.6
	2.0	2.5	5.8						5.8	4.2	0.73	0.73	8.3	7.9
120	1.0	0.9	2.1	Operation not recommended					Operation not recommended					
	1.5	1.6	3.7						5.1	3.9	0.76	0.81	7.9	6.3
	2.0	2.4	5.5						5.2	4.0	0.76	0.79	7.9	6.6

10/03/2012

The manufacturer works continually to improve its products. As a result, the design and specifications of each product at the time of order may be changed without notice. Purchaser's approval of this data set signifies that the equipment is acceptable under the provisions of the job specification. Statements and other information contained herein are not express warranties and do not form the basis of any bargain between the parties, but are merely the manufacturer's opinion or commendation of its products.

Contractor: \_\_\_\_\_ P.O.: \_\_\_\_\_

Engineer: \_\_\_\_\_

Project Name: \_\_\_\_\_ Unit Tag: \_\_\_\_\_



## ZB009 - Performance Data

### Single Speed with PSC (350 CFM)

EWT °F	Flow GPM	WPD		HEATING - EAT 70°F					COOLING - EAT 80/67°F					
		psi	ft	HC MBtu/h	Power kW	HE MBtu/h	LAT °F	COP	TC MBtu/h	SC MBtu/h	S/T Ratio	Power kW	HR MBtu/h	EER
20	1.5	2.0	4.6	Operation not recommended					Operation not recommended					
	2.0	3.1	7.2	Operation not recommended					Operation not recommended					
	3.0	6.4	14.8	6.1	0.69	3.8	84.2	2.60	Operation not recommended					
30	1.5	1.9	4.4	Operation not recommended					Operation not recommended					
	2.0	3.0	6.9	7.4	0.72	5.0	87.7	3.04	10.2	6.9	0.67	0.49	11.8	20.9
	3.0	6.3	14.6	7.2	0.71	4.8	87.1	2.96	10.3	7.0	0.68	0.46	11.9	22.6
40	1.5	1.8	4.2	Operation not recommended					Operation not recommended					
	2.0	2.9	6.7	8.1	0.73	5.6	89.5	3.26	10.1	7.1	0.70	0.51	11.9	19.7
	3.0	6.2	14.3	8.2	0.73	5.7	89.6	3.26	10.3	7.2	0.70	0.48	11.9	21.3
50	1.5	1.7	3.9	8.7	0.74	6.2	91.0	3.46	10.0	7.4	0.74	0.56	11.9	17.9
	2.0	2.8	6.5	8.8	0.74	6.3	91.4	3.49	10.1	7.4	0.73	0.54	11.9	18.6
	3.0	6.3	14.6	9.1	0.75	6.5	92.1	3.55	10.3	7.5	0.72	0.51	12.0	20.3
60	1.5	1.6	3.7	9.5	0.75	7.0	93.2	3.72	9.4	7.2	0.76	0.61	11.5	15.4
	2.0	2.7	6.2	9.7	0.75	7.1	93.6	3.76	9.4	7.2	0.76	0.59	11.5	15.9
	3.0	6.2	14.3	10.0	0.76	7.4	94.4	3.85	9.5	7.3	0.76	0.56	11.4	16.9
70	1.5	1.5	3.5	10.3	0.77	7.7	95.4	3.96	8.9	7.0	0.79	0.66	11.1	13.4
	2.0	2.6	6.0	10.5	0.77	7.9	95.8	4.02	8.8	7.0	0.79	0.65	11.0	13.7
	3.0	6.1	14.0	10.8	0.77	8.2	96.6	4.13	8.8	7.1	0.80	0.62	10.9	14.2
80	1.5	1.4	3.2	11.5	0.77	8.9	98.5	4.38	8.1	6.6	0.82	0.74	10.6	10.9
	2.0	2.5	5.8	11.7	0.78	9.1	98.9	4.42	8.1	6.7	0.82	0.71	10.6	11.5
	3.0	6.0	13.9	12.0	0.78	9.3	99.6	4.48	8.2	6.8	0.83	0.68	10.5	12.0
90	1.5	1.3	3.0	12.7	0.78	10.0	101.6	4.80	7.3	6.3	0.86	0.81	10.1	9.1
	2.0	2.4	5.5	12.9	0.79	10.2	102.1	4.81	7.5	6.4	0.86	0.77	10.1	9.6
	3.0	5.9	13.6	13.1	0.80	10.4	102.6	4.82	7.6	6.6	0.86	0.75	10.2	10.2
100	1.5	1.2	2.8	Operation not recommended					Operation not recommended					
	2.0	2.3	5.3						6.9   6.2   0.90   0.84   9.8   8.2					
	3.0	5.8	13.4						7.0   6.3   0.90   0.82   9.8   8.6					
110	1.5	1.1	2.5	Operation not recommended					Operation not recommended					
	2.0	2.2	5.1						6.2   5.9   0.94   0.91   9.4   6.9					
	3.0	5.7	13.2						6.4   6.0   0.94   0.89   9.4   7.2					
120	1.5	1.0	2.3	Operation not recommended					Operation not recommended					
	2.0	2.1	4.9						5.1   5.0   0.98   1.00   8.5   5.1					
	3.0	5.6	12.9						5.2   5.1   0.98   0.97   8.5   5.4					

9/5/2012

The manufacturer works continually to improve its products. As a result, the design and specifications of each product at the time of order may be changed without notice. Purchaser's approval of this data set signifies that the equipment is acceptable under the provisions of the job specification. Statements and other information contained herein are not express warranties and do not form the basis of any bargain between the parties, but are merely the manufacturer's opinion or commendation of its products.

Contractor: \_\_\_\_\_ P.O.: \_\_\_\_\_

Engineer: \_\_\_\_\_

Project Name: \_\_\_\_\_ Unit Tag: \_\_\_\_\_

**Arbor Base Series Commercial  
Geothermal/Water Source Heat Pumps  
0.5-6 Tons, 60Hz**



## ZB012 - Performance Data

### Single Speed with PSC (400 CFM)

EWT °F	Flow GPM	WPD		HEATING - EAT 70°F					COOLING - EAT 80/67°F					
		psi	ft	HC MBtu/h	Power kW	HE MBtu/h	LAT °F	COP	TC MBtu/h	SC MBtu/h	S/T Ratio	Power kW	HR MBtu/h	EER
20	1.5	1.2	2.8	Operation not recommended					Operation not recommended					
	2.5	2.5	5.8	Operation not recommended					Operation not recommended					
	3.5	4.3	9.9	8.3	0.94	5.1	87.3	2.61	Operation not recommended					
30	1.5	1.1	2.6	Operation not recommended					Operation not recommended					
	2.5	2.4	5.5	10.0	0.99	6.6	91.2	2.97	12.5	8.4	0.67	0.64	14.7	19.5
	3.5	4.2	9.7	9.8	0.98	6.4	90.6	2.91	12.7	8.5	0.67	0.60	14.7	21.1
40	1.5	1.1	2.5	Operation not recommended					Operation not recommended					
	2.5	2.4	5.5	10.9	1.01	7.5	93.3	3.16	12.5	8.6	0.68	0.70	14.9	18.0
	3.5	4.1	9.5	11.0	1.02	7.6	93.6	3.18	12.7	8.7	0.69	0.66	14.9	19.3
50	1.5	1.1	2.5	11.5	1.03	8.0	94.6	3.27	12.4	8.8	0.70	0.80	15.2	15.7
	2.5	2.3	5.3	11.9	1.04	8.4	95.6	3.35	12.6	8.8	0.70	0.75	15.1	16.6
	3.5	4.0	9.2	12.3	1.06	8.7	96.5	3.43	12.7	8.9	0.70	0.71	15.1	17.7
60	1.5	1.0	2.3	12.6	1.07	9.0	97.2	3.47	11.9	8.6	0.72	0.86	14.9	13.8
	2.5	2.2	5.0	13.1	1.07	9.4	98.2	3.57	12.1	8.7	0.72	0.82	14.9	14.6
	3.5	3.8	8.8	13.5	1.08	9.8	99.3	3.66	12.2	8.7	0.71	0.79	14.9	15.6
70	1.5	1.0	2.4	13.7	1.10	9.9	99.7	3.65	11.4	8.4	0.74	0.93	14.6	12.2
	2.5	2.2	5.1	14.2	1.10	10.4	100.9	3.77	11.6	8.5	0.73	0.90	14.7	13.0
	3.5	3.7	8.6	14.7	1.11	10.9	102.1	3.89	11.8	8.6	0.72	0.86	14.8	13.8
80	1.5	1.0	2.3	15.4	1.12	11.6	103.7	4.05	10.6	8.1	0.76	1.01	14.1	10.5
	2.5	2.1	4.9	15.8	1.13	12.0	104.6	4.11	10.8	8.2	0.76	0.97	14.1	11.2
	3.5	3.6	8.3	16.2	1.14	12.3	105.5	4.18	11.0	8.3	0.75	0.94	14.2	11.8
90	1.5	0.9	2.1	17.2	1.13	13.3	107.7	4.43	9.8	7.7	0.78	1.10	13.6	8.9
	2.5	2.0	4.6	17.4	1.15	13.5	108.3	4.44	10.0	7.8	0.78	1.05	13.6	9.5
	3.5	3.4	7.9	17.7	1.16	13.7	109.0	4.46	10.2	8.0	0.79	1.02	13.6	10.0
100	1.5	0.9	2.1	Operation not recommended					Operation not recommended					
	2.5	1.9	4.4						8.7	7.5	0.86	1.14	12.6	7.7
	3.5	3.3	7.6						8.9	7.6	0.86	1.10	12.7	8.0
110	1.5	0.9	2.1	Operation not recommended					Operation not recommended					
	2.5	1.9	4.4						7.4	7.1	0.95	1.23	11.6	6.1
	3.5	3.2	7.4						7.6	7.2	0.95	1.19	11.7	6.4
120	1.5	0.8	1.8	Operation not recommended					Operation not recommended					
	2.5	1.8	4.2						6.7	6.6	0.99	1.32	11.2	5.1
	3.5	3.1	7.2						6.9	6.7	0.98	1.28	11.3	5.4

9/5/2012

The manufacturer works continually to improve its products. As a result, the design and specifications of each product at the time of order may be changed without notice. Purchaser's approval of this data set signifies that the equipment is acceptable under the provisions of the job specification. Statements and other information contained herein are not express warranties and do not form the basis of any bargain between the parties, but are merely the manufacturer's opinion or commendation of its products.

Contractor: \_\_\_\_\_ P.O.: \_\_\_\_\_

Engineer: \_\_\_\_\_

Project Name: \_\_\_\_\_ Unit Tag: \_\_\_\_\_



## ZB015 - Performance Data

### Single Speed with PSC (500 CFM)

EWT °F	Flow GPM	WPD		HEATING - EAT 70°F					COOLING - EAT 80/67°F					
		psi	ft	HC MBtu/h	Power kW	HE MBtu/h	LAT °F	COP	TC MBtu/h	SC MBtu/h	S/T Ratio	Power kW	HR MBtu/h	EER
20	2.0	1.9	4.4	Operation not recommended					Operation not recommended					
	3.0	3.4	7.9	Operation not recommended					Operation not recommended					
	4.0	5.1	11.7	9.2	1.00	5.7	85.0	2.67	Operation not recommended					
30	2.0	1.8	4.2	Operation not recommended					Operation not recommended					
	3.0	3.3	7.6	11.2	1.04	7.7	88.8	3.16	16.9	11.6	0.68	0.69	19.2	24.4
	4.0	5.0	11.5	10.7	1.04	7.2	87.9	3.04	17.1	11.8	0.69	0.65	19.3	26.3
40	2.0	1.8	4.2	Operation not recommended					Operation not recommended					
	3.0	3.2	7.4	12.2	1.06	8.6	90.6	3.38	16.6	11.6	0.70	0.74	19.1	22.3
	4.0	5.0	11.6	12.1	1.06	8.5	90.5	3.36	16.8	11.7	0.70	0.71	19.2	23.8
50	2.0	1.7	3.9	12.9	1.07	9.2	91.8	3.53	16.1	11.5	0.72	0.83	18.9	19.4
	3.0	3.1	7.2	13.2	1.08	9.5	92.5	3.60	16.3	11.6	0.71	0.80	19.0	20.5
	4.0	4.9	11.3	13.5	1.08	9.9	93.1	3.67	16.5	11.7	0.71	0.76	19.1	21.6
60	2.0	1.6	3.7	14.1	1.09	10.3	94.0	3.78	15.3	11.1	0.72	0.92	18.4	16.6
	3.0	3.0	6.9	14.4	1.09	10.7	94.6	3.85	15.5	11.2	0.72	0.89	18.5	17.5
	4.0	4.9	11.3	14.7	1.10	11.0	95.2	3.93	15.7	11.3	0.72	0.85	18.6	18.5
70	2.0	1.6	3.6	15.3	1.11	11.5	96.3	4.03	14.5	10.6	0.73	1.02	18.0	14.3
	3.0	2.9	6.7	15.6	1.11	11.8	96.8	4.10	14.8	10.8	0.73	0.98	18.1	15.1
	4.0	4.8	11.1	15.9	1.12	12.1	97.4	4.17	15.0	10.9	0.72	0.94	18.2	16.0
80	2.0	1.5	3.5	16.2	1.11	12.4	98.1	4.27	13.7	10.2	0.75	1.12	17.5	12.2
	3.0	2.8	6.5	16.5	1.12	12.7	98.6	4.31	13.9	10.4	0.75	1.07	17.6	13.0
	4.0	4.8	11.1	16.8	1.13	13.0	99.1	4.36	14.2	10.5	0.74	1.03	17.7	13.7
90	2.0	1.4	3.2	17.2	1.12	13.4	99.9	4.51	12.9	9.8	0.76	1.22	17.0	10.5
	3.0	2.6	6.0	17.5	1.13	13.6	100.4	4.52	13.1	10.0	0.77	1.17	17.0	11.2
	4.0	4.7	10.9	17.7	1.15	13.8	100.9	4.54	13.3	10.1	0.76	1.13	17.2	11.8
100	2.0	1.3	3.0	Operation not recommended					Operation not recommended					
	3.0	2.4	5.5						12.0   9.5   0.80   1.28   16.3   9.3					
	4.0	4.6	10.6						12.1   9.6   0.79   1.24   16.4   9.8					
110	2.0	1.2	2.8	Operation not recommended					Operation not recommended					
	3.0	2.3	5.3						10.7   9.0   0.84   1.40   15.5   7.7					
	4.0	4.6	10.6						11.0   9.2   0.84   1.36   15.6   8.1					
120	2.0	1.1	2.5	Operation not recommended					Operation not recommended					
	3.0	2.2	5.1						9.2   8.5   0.92   1.52   14.4   6.1					
	4.0	4.5	10.4						9.4   8.7   0.92   1.48   14.5   6.4					

9/5/2012

The manufacturer works continually to improve its products. As a result, the design and specifications of each product at the time of order may be changed without notice. Purchaser's approval of this data set signifies that the equipment is acceptable under the provisions of the job specification. Statements and other information contained herein are not express warranties and do not form the basis of any bargain between the parties, but are merely the manufacturer's opinion or commendation of its products.



Contractor: \_\_\_\_\_ P.O.: \_\_\_\_\_

Engineer: \_\_\_\_\_

Project Name: \_\_\_\_\_ Unit Tag: \_\_\_\_\_



## ZB018 - Performance Data

### Single Speed with PSC (600 CFM)

EWT °F	Flow GPM	WPD		HEATING - EAT 70°F					COOLING - EAT 80/67°F					
		psi	ft	HC MBtu/h	Power kW	HE MBtu/h	LAT °F	COP	TC MBtu/h	SC MBtu/h	S/T Ratio	Power kW	HR MBtu/h	EER
20	3.0	3.4	7.9	Operation not recommended					Operation not recommended					
	4.0	4.9	11.3											
	5.0	6.5	15.0	11.7	1.29	7.3	86.1	2.66						
30	3.0	3.3	7.6	Operation not recommended					Operation not recommended					
	4.0	4.7	10.9	13.8	1.36	9.2	89.3	2.99	22.1	14.5	0.66	0.92	25.2	24.1
	5.0	6.2	14.2	13.5	1.34	8.9	88.8	2.94	22.4	14.8	0.66	0.86	25.3	26.1
40	3.0	3.3	7.6	Operation not recommended					Operation not recommended					
	4.0	4.7	10.9	15.1	1.38	10.4	91.3	3.20	21.9	14.4	0.66	0.97	25.2	22.5
	5.0	6.2	14.3	15.1	1.37	10.4	91.3	3.22	21.9	14.5	0.66	0.94	25.1	23.4
50	3.0	3.2	7.4	16.2	1.41	11.4	93.0	3.38	21.8	14.4	0.66	1.05	25.4	20.8
	4.0	4.2	9.7	16.5	1.40	11.7	93.4	3.44	21.6	14.3	0.66	1.03	25.1	21.0
	5.0	5.2	11.9	16.7	1.40	11.9	93.8	3.50	21.4	14.3	0.67	1.01	24.9	21.2
60	3.0	3.1	7.2	17.9	1.42	13.0	95.5	3.68	20.7	13.9	0.67	1.17	24.7	17.8
	4.0	4.1	9.4	18.0	1.43	13.2	95.9	3.70	20.5	13.9	0.68	1.15	24.4	17.9
	5.0	5.0	11.6	18.2	1.43	13.4	96.2	3.73	20.2	13.8	0.68	1.13	24.1	18.0
70	3.0	3.0	6.9	19.5	1.44	14.6	98.1	3.97	19.6	13.5	0.69	1.28	24.0	15.3
	4.0	3.9	8.9	19.6	1.45	14.7	98.3	3.96	19.3	13.4	0.69	1.26	23.6	15.3
	5.0	4.7	10.9	19.8	1.47	14.8	98.5	3.95	19.1	13.3	0.70	1.24	23.3	15.4
80	3.0	2.9	6.7	20.3	1.45	15.4	99.4	4.13	18.4	12.8	0.70	1.49	23.5	12.3
	4.0	3.7	8.4	20.6	1.46	15.6	99.8	4.13	18.4	12.9	0.70	1.42	23.2	12.9
	5.0	4.4	10.2	20.8	1.48	15.8	100.1	4.13	18.4	12.9	0.70	1.37	23.1	13.4
90	3.0	2.8	6.5	21.2	1.45	16.2	100.7	4.28	17.1	12.2	0.71	1.63	22.7	10.5
	4.0	3.6	8.3	21.5	1.47	16.5	101.2	4.29	17.4	12.4	0.71	1.56	22.7	11.2
	5.0	4.1	9.5	21.9	1.49	16.8	101.7	4.30	17.8	12.6	0.71	1.51	22.9	11.8
100	3.0	2.7	6.2	Operation not recommended					Operation not recommended					
	4.0	3.5	8.1						16.6	12.0	0.72	1.69	22.3	9.8
	5.0	3.9	9.0						16.8	12.1	0.72	1.63	22.4	10.3
110	3.0	2.6	6.0	Operation not recommended					Operation not recommended					
	4.0	3.1	7.0						15.5	11.4	0.73	1.81	21.7	8.6
	5.0	3.5	8.1						15.8	11.5	0.73	1.76	21.8	9.0
120	3.0	2.5	5.8	Operation not recommended					Operation not recommended					
	4.0	3.0	6.9						13.1	9.8	0.74	1.97	19.8	6.7
	5.0	3.4	7.9						13.4	9.9	0.74	1.91	19.9	7.0

5/1/11

The manufacturer works continually to improve its products. As a result, the design and specifications of each product at the time of order may be changed without notice. Purchaser's approval of this data set signifies that the equipment is acceptable under the provisions of the job specification. Statements and other information contained herein are not express warranties and do not form the basis of any bargain between the parties, but are merely the manufacturer's opinion or commendation of its products.

Contractor: \_\_\_\_\_ P.O.: \_\_\_\_\_

Engineer: \_\_\_\_\_

Project Name: \_\_\_\_\_ Unit Tag: \_\_\_\_\_



## ZB024 - Performance Data

### Single Speed with PSC (800 CFM)

EWT °F	Flow GPM	WPD		HEATING - EAT 70°F					COOLING - EAT 80/67°F					
		psi	ft	HC MBtu/h	Power kW	HE MBtu/h	LAT °F	COP	TC MBtu/h	SC MBtu/h	S/T Ratio	Power kW	HR MBtu/h	EER
20	3.0	3.3	7.6	Operation not recommended					Operation not recommended					
	4.5	7.0	16.1	Operation not recommended					Operation not recommended					
	6.0	10.6	24.4	13.8	1.33	9.3	84.0	3.06	Operation not recommended					
30	3.0	3.2	7.4	Operation not recommended					Operation not recommended					
	4.5	6.1	14.1	18.7	1.60	13.2	89.6	3.43	29.3	19.6	0.67	1.11	33.1	26.4
	6.0	9.0	20.8	16.8	1.45	11.9	87.4	3.40	29.7	20.0	0.67	1.04	33.3	28.5
40	3.0	3.2	7.4	Operation not recommended					Operation not recommended					
	4.5	6.1	14.1	20.3	1.61	14.8	91.5	3.69	28.8	19.5	0.68	1.25	33.1	23.1
	6.0	9.0	20.8	19.8	1.55	14.5	91.0	3.74	29.4	19.8	0.68	1.18	33.4	25.0
50	3.0	3.1	7.1	21.4	1.61	15.9	92.7	3.89	27.7	19.3	0.70	1.45	32.6	19.1
	4.5	5.5	12.7	22.1	1.63	16.5	93.6	3.97	28.3	19.5	0.69	1.38	33.0	20.5
	6.0	7.9	18.2	22.9	1.66	17.2	94.5	4.04	29.0	19.7	0.68	1.31	33.4	22.2
60	3.0	3.0	6.9	23.8	1.68	18.0	95.5	4.15	26.3	18.5	0.70	1.59	31.7	16.6
	4.5	5.3	12.1	24.2	1.65	18.5	96.0	4.29	27.0	18.8	0.70	1.52	32.2	17.8
	6.0	7.5	17.3	24.6	1.63	19.0	96.4	4.43	27.6	19.1	0.69	1.45	32.6	19.1
70	3.0	2.9	6.7	26.2	1.75	20.2	98.3	4.38	24.9	17.7	0.71	1.72	30.8	14.5
	4.5	4.9	11.3	26.2	1.67	20.5	98.3	4.60	25.6	18.1	0.71	1.66	31.3	15.4
	6.0	6.9	16.0	26.3	1.59	20.8	98.4	4.84	26.3	18.4	0.70	1.59	31.7	16.5
80	3.0	2.8	6.5	27.4	1.77	21.4	99.7	4.54	23.4	17.3	0.74	1.89	29.8	12.4
	4.5	4.7	10.7	27.6	1.74	21.7	100.0	4.65	23.9	17.5	0.73	1.80	30.0	13.3
	6.0	6.5	15.0	27.9	1.71	22.1	100.3	4.77	24.4	17.8	0.73	1.74	30.4	14.0
90	3.0	2.7	6.2	28.6	1.79	22.5	101.1	4.69	21.8	16.8	0.77	2.05	28.8	10.7
	4.5	4.5	10.4	29.1	1.81	22.9	101.7	4.70	22.2	17.0	0.77	1.95	28.8	11.3
	6.0	6.3	14.5	29.5	1.84	23.3	102.2	4.71	22.6	17.2	0.76	1.89	29.1	12.0
100	3.0	2.6	6.0	Operation not recommended					Operation not recommended					
	4.5	4.3	9.9	Operation not recommended					20.4	16.2	0.79	2.09	27.6	9.8
	6.0	6.0	13.9	Operation not recommended					20.7	16.3	0.79	2.03	27.7	10.2
110	3.0	2.5	5.8	Operation not recommended					Operation not recommended					
	4.5	4.2	9.6	Operation not recommended					18.5	15.3	0.83	2.23	26.1	8.3
	6.0	5.8	13.4	Operation not recommended					18.9	15.5	0.82	2.17	26.3	8.7
120	3.0	2.4	5.5	Operation not recommended					Operation not recommended					
	4.5	4.0	9.2	Operation not recommended					16.1	13.8	0.86	2.38	24.2	6.8
	6.0	5.6	13.0	Operation not recommended					16.4	14.0	0.85	2.31	24.3	7.1

5/1/11

The manufacturer works continually to improve its products. As a result, the design and specifications of each product at the time of order may be changed without notice. Purchaser's approval of this data set signifies that the equipment is acceptable under the provisions of the job specification. Statements and other information contained herein are not express warranties and do not form the basis of any bargain between the parties, but are merely the manufacturer's opinion or commendation of its products.

Contractor: \_\_\_\_\_ P.O.: \_\_\_\_\_

Engineer: \_\_\_\_\_

Project Name: \_\_\_\_\_ Unit Tag: \_\_\_\_\_



## ZB030 - Performance Data

### Single Speed with PSC (1000 CFM)

EWT °F	Flow GPM	WPD		HEATING - EAT 70°F					COOLING - EAT 80/67°F					
		psi	ft	HC MBtu/h	Power kW	HE MBtu/h	LAT °F	COP	TC MBtu/h	SC MBtu/h	S/T Ratio	Power kW	HR MBtu/h	EER
20	4.0	2.5	5.8	Operation not recommended					Operation not recommended					
	6.0	5.2	12.0	Operation not recommended					Operation not recommended					
	8.0	7.9	18.3	16.8	1.60	11.4	83.6	3.08	Operation not recommended					
30	4.0	2.4	5.5	Operation not recommended					Operation not recommended					
	6.0	5.1	11.8	22.2	1.77	16.1	88.5	3.67	35.0	23.1	0.66	1.17	39.0	29.9
	8.0	7.8	18.0	20.5	1.74	14.5	87.0	3.44	35.5	23.6	0.66	1.10	39.2	32.3
40	4.0	2.3	5.3	Operation not recommended					Operation not recommended					
	6.0	4.9	11.3	24.7	1.86	18.3	90.8	3.88	35.1	23.6	0.67	1.32	39.7	26.6
	8.0	7.5	17.3	24.4	1.86	18.0	90.6	3.84	35.8	24.0	0.67	1.24	40.0	28.9
50	4.0	2.3	5.3	26.5	1.93	19.9	92.5	4.02	34.6	23.8	0.69	1.56	39.9	22.1
	6.0	4.9	11.3	27.4	1.96	20.7	93.4	4.10	35.3	24.1	0.68	1.47	40.3	24.0
	8.0	7.5	17.2	28.3	1.98	21.6	94.2	4.19	36.0	24.4	0.68	1.38	40.7	26.1
60	4.0	2.2	5.1	29.6	2.03	22.6	95.4	4.28	32.7	22.9	0.70	1.73	38.6	18.9
	6.0	4.7	10.9	30.6	2.06	23.6	96.4	4.36	33.4	23.2	0.69	1.65	39.0	20.3
	8.0	7.1	16.4	31.7	2.09	24.6	97.3	4.45	34.1	23.5	0.69	1.56	39.4	21.8
70	4.0	2.2	5.0	32.7	2.12	25.4	98.2	4.51	30.9	22.0	0.71	1.90	37.4	16.3
	6.0	4.7	10.9	33.9	2.16	26.5	99.4	4.60	31.5	22.3	0.71	1.82	37.7	17.3
	8.0	7.1	16.4	35.1	2.19	27.6	100.5	4.69	32.1	22.7	0.71	1.74	38.1	18.5
80	4.0	2.1	4.9	35.7	2.19	28.2	101.0	4.78	29.0	21.1	0.73	2.08	36.1	14.0
	6.0	4.6	10.6	36.6	2.22	29.0	101.9	4.82	29.5	21.4	0.73	1.98	36.2	14.9
	8.0	7.0	16.2	37.5	2.25	29.8	102.7	4.87	30.1	21.8	0.72	1.92	36.6	15.7
90	4.0	2.0	4.6	38.7	2.26	31.0	103.8	5.03	27.0	20.2	0.75	2.26	34.8	11.9
	6.0	4.5	10.4	39.3	2.29	31.5	104.4	5.04	27.5	20.5	0.75	2.16	34.8	12.7
	8.0	6.9	16.0	39.9	2.32	32.0	105.0	5.05	28.0	20.8	0.74	2.09	35.2	13.4
100	4.0	1.9	4.4	Operation not recommended					Operation not recommended					
	6.0	4.4	10.2	Operation not recommended					25.3	19.6	0.77	2.33	33.3	10.8
	8.0	6.8	15.7	Operation not recommended					25.7	19.8	0.77	2.26	33.4	11.4
110	4.0	1.8	4.2	Operation not recommended					Operation not recommended					
	6.0	4.3	9.9	Operation not recommended					22.9	18.4	0.80	2.49	31.4	9.2
	8.0	6.7	15.5	Operation not recommended					23.3	18.7	0.80	2.43	31.6	9.6
120	4.0	1.7	3.9	Operation not recommended					Operation not recommended					
	6.0	4.2	9.7	Operation not recommended					20.0	16.8	0.84	2.67	29.2	7.5
	8.0	6.6	15.2	Operation not recommended					20.5	17.1	0.84	2.59	29.3	7.9

5/1/11

The manufacturer works continually to improve its products. As a result, the design and specifications of each product at the time of order may be changed without notice. Purchaser's approval of this data set signifies that the equipment is acceptable under the provisions of the job specification. Statements and other information contained herein are not express warranties and do not form the basis of any bargain between the parties, but are merely the manufacturer's opinion or commendation of its products.

Contractor: \_\_\_\_\_ P.O.: \_\_\_\_\_

Engineer: \_\_\_\_\_

Project Name: \_\_\_\_\_ Unit Tag: \_\_\_\_\_



## ZB036 - Performance Data

### Single Speed with PSC (1150 CFM)

EWT °F	Flow GPM	WPD		HEATING - EAT 70°F					COOLING - EAT 80/67°F					
		psi	ft	HC MBtu/h	Power kW	HE MBtu/h	LAT °F	COP	TC MBtu/h	SC MBtu/h	S/T Ratio	Power kW	HR MBtu/h	EER
20	5.0	2.1	4.9	Operation not recommended					Operation not recommended					
	7.0	3.7	8.5											
	9.0	5.3	12.2	22.3	1.97	15.6	86.0	3.32						
30	5.0	2.0	4.6	Operation not recommended					Operation not recommended					
	7.0	3.6	8.3	27.3	2.15	20.0	90.0	3.73	41.8	26.6	0.64	1.44	46.7	29.1
	9.0	5.2	12.0	25.6	2.09	18.4	88.6	3.58	42.4	27.1	0.64	1.35	46.9	31.4
40	5.0	2.0	4.6	Operation not recommended					Operation not recommended					
	7.0	3.6	8.3	30.5	2.25	22.8	92.6	3.97	42.2	27.6	0.65	1.61	47.7	26.2
	9.0	5.2	12.0	30.4	2.25	22.7	92.5	3.96	42.7	27.9	0.65	1.52	47.9	28.0
50	5.0	1.9	4.4	32.7	2.32	24.8	94.3	4.13	42.2	28.4	0.67	1.88	48.6	22.5
	7.0	3.5	8.1	34.0	2.36	25.9	95.4	4.21	42.6	28.5	0.67	1.79	48.7	23.8
	9.0	5.1	11.7	35.2	2.41	27.0	96.4	4.29	43.0	28.6	0.66	1.70	48.8	25.3
60	5.0	1.8	4.2	36.9	2.45	28.5	97.7	4.42	40.4	27.9	0.69	2.09	47.5	19.3
	7.0	3.4	7.9	38.1	2.48	29.7	98.7	4.50	40.9	28.0	0.68	2.00	47.7	20.4
	9.0	5.0	11.6	39.4	2.52	30.8	99.7	4.58	41.4	28.1	0.68	1.91	48.0	21.7
70	5.0	1.7	3.9	41.1	2.58	32.3	101.1	4.67	38.6	27.3	0.71	2.30	46.4	16.8
	7.0	3.3	7.6	42.3	2.61	33.4	102.1	4.76	39.2	27.5	0.70	2.21	46.8	17.7
	9.0	4.8	11.1	43.6	2.64	34.6	103.1	4.84	39.9	27.6	0.69	2.13	47.1	18.8
80	5.0	1.6	3.7	44.3	2.67	35.2	103.7	4.87	36.0	26.2	0.73	2.55	44.7	14.1
	7.0	3.2	7.3	45.3	2.70	36.1	104.5	4.92	36.6	26.3	0.72	2.43	44.9	15.0
	9.0	4.7	10.9	46.3	2.73	37.0	105.3	4.97	37.3	26.5	0.71	2.35	45.3	15.8
90	5.0	1.5	3.5	47.5	2.76	38.1	106.3	5.05	33.4	25.0	0.75	2.80	43.0	11.9
	7.0	3.1	7.2	48.2	2.79	38.7	106.8	5.06	34.0	25.2	0.74	2.67	43.1	12.7
	9.0	4.6	10.6	49.0	2.83	39.3	107.4	5.08	34.7	25.4	0.73	2.58	43.5	13.4
100	5.0	1.5	3.5	Operation not recommended					Operation not recommended					
	7.0	3.1	7.2						31.5	24.3	0.77	2.89	41.3	10.9
	9.0	4.6	10.6						32.0	24.5	0.76	2.79	41.5	11.5
110	5.0	1.4	3.2	Operation not recommended					Operation not recommended					
	7.0	2.9	6.7						28.7	23.2	0.81	3.09	39.3	9.3
	9.0	4.4	10.0						29.3	23.5	0.80	3.00	39.6	9.8
120	5.0	1.3	3.0	Operation not recommended					Operation not recommended					
	7.0	2.8	6.5						25.8	22.6	0.88	3.29	37.0	7.8
	9.0	4.3	9.9						26.3	23.0	0.87	3.20	37.2	8.2

5/1/11

The manufacturer works continually to improve its products. As a result, the design and specifications of each product at the time of order may be changed without notice. Purchaser's approval of this data set signifies that the equipment is acceptable under the provisions of the job specification. Statements and other information contained herein are not express warranties and do not form the basis of any bargain between the parties, but are merely the manufacturer's opinion or commendation of its products.

Contractor: \_\_\_\_\_ P.O.: \_\_\_\_\_

Engineer: \_\_\_\_\_

Project Name: \_\_\_\_\_ Unit Tag: \_\_\_\_\_



## ZB041 - Performance Data

### Single Speed - PSC (1100 CFM)

EWT °F	Flow GPM	WPD		HEATING - EAT 70°F					COOLING - EAT 80/67°F					
		psi	ft	HC MBtu/h	Power kW	HE MBtu/h	LAT °F	COP	TC MBtu/h	SC MBtu/h	S/T Ratio	Power kW	HR MBtu/h	EER
20	5.0	1.6	3.8	Operation not recommended					Operation not recommended					
	8.0	3.6	8.2	Operation not recommended					Operation not recommended					
	11.0	8.0	18.5	25.2	2.42	16.9	89.2	3.05	Operation not recommended					
30	5.0	1.5	3.4	Operation not recommended					Operation not recommended					
	8.0	3.4	7.8	30.9	2.96	20.8	94.0	3.06	45.1	31.7	0.70	1.83	51.3	24.6
	11.0	7.9	18.1	29.7	2.92	19.7	93.0	2.98	45.7	32.3	0.71	1.72	51.6	26.6
40	5.0	1.3	3.0	Operation not recommended					Operation not recommended					
	8.0	3.2	7.5	34.8	3.03	24.4	97.3	3.36	47.2	32.9	0.70	2.01	54.0	23.5
	11.0	7.7	17.8	35.3	3.02	24.9	97.7	3.42	47.8	33.3	0.70	1.89	54.2	25.4
50	5.0	1.2	2.7	37.5	3.10	26.9	99.6	3.55	48.7	33.8	0.69	2.32	56.6	21.0
	8.0	3.1	7.1	39.2	3.11	28.5	101.0	3.69	49.3	34.1	0.69	2.19	56.8	22.6
	11.0	7.5	17.4	40.8	3.12	30.2	102.3	3.83	49.9	34.3	0.69	2.05	56.9	24.3
60	5.0	1.0	2.3	42.7	3.16	31.9	103.9	3.96	46.1	32.8	0.71	2.53	54.7	18.2
	8.0	2.9	6.7	44.5	3.19	33.6	105.4	4.09	46.8	33.1	0.71	2.41	55.0	19.5
	11.0	7.4	17.0	46.3	3.22	35.3	106.9	4.21	47.6	33.4	0.70	2.29	55.4	20.8
70	5.0	0.9	2.0	47.9	3.22	36.9	108.3	4.36	43.4	31.7	0.73	2.73	52.7	15.9
	8.0	2.8	6.4	49.8	3.27	38.6	109.9	4.46	44.4	32.1	0.72	2.63	53.3	16.9
	11.0	7.2	16.7	51.7	3.32	40.4	111.5	4.56	45.3	32.4	0.72	2.52	53.9	18.0
80	5.0	0.7	1.6	53.5	3.33	42.1	113.0	4.71	40.9	30.8	0.75	2.99	51.1	13.7
	8.0	2.6	6.0	54.9	3.37	43.4	114.2	4.77	41.7	31.0	0.74	2.85	51.4	14.6
	11.0	7.1	16.3	56.3	3.42	44.6	115.4	4.82	42.6	31.3	0.74	2.76	52.0	15.4
90	5.0	0.5	1.2	59.1	3.43	47.4	117.7	5.04	38.4	29.8	0.78	3.25	49.5	11.8
	8.0	2.5	5.7	60.0	3.48	48.1	118.5	5.06	39.0	29.9	0.77	3.10	49.6	12.6
	11.0	6.9	16.0	60.9	3.52	48.9	119.3	5.07	39.8	30.2	0.76	3.00	50.0	13.3
100	5.0	0.4	0.9	Operation not recommended					Operation not recommended					
	8.0	2.3	5.3	Operation not recommended					36.2	28.7	0.79	3.46	48.0	10.5
	11.0	6.8	15.6	Operation not recommended					36.8	29.0	0.79	3.35	48.2	11.0
110	5.0	0.4	0.9	Operation not recommended					Operation not recommended					
	8.0	2.1	4.9	Operation not recommended					33.0	27.3	0.83	3.80	46.0	8.7
	11.0	6.6	15.2	Operation not recommended					33.7	27.7	0.82	3.70	46.3	9.1
120	5.0	0.4	0.9	Operation not recommended					Operation not recommended					
	8.0	2.0	4.6	Operation not recommended					29.8	26.2	0.88	4.22	44.2	7.0
	11.0	6.5	14.9	Operation not recommended					30.4	26.6	0.88	4.10	44.4	7.4

10/15/15

The manufacturer works continually to improve its products. As a result, the design and specifications of each product at the time of order may be changed without notice. Purchaser's approval of this data set signifies that the equipment is acceptable under the provisions of the job specification. Statements and other information contained herein are not express warranties and do not form the basis of any bargain between the parties, but are merely the manufacturer's opinion or commendation of its products.

Contractor: \_\_\_\_\_ P.O.: \_\_\_\_\_

Engineer: \_\_\_\_\_

Project Name: \_\_\_\_\_ Unit Tag: \_\_\_\_\_



## ZB042 - Performance Data

### Single Speed with PSC (1400 CFM)

EWT °F	Flow GPM	WPD		HEATING - EAT 70°F					COOLING - EAT 80/67°F					
		psi	ft	HC MBtu/h	Power kW	HE MBtu/h	LAT °F	COP	TC MBtu/h	SC MBtu/h	S/T Ratio	Power kW	HR MBtu/h	EER
20	5.0	2.2	5.1	Operation not recommended					Operation not recommended					
	8.0	4.9	11.3											
	11.0	7.6	17.6	25.4	2.27	17.7	84.8	3.28						
30	5.0	2.1	4.9	Operation not recommended					Operation not recommended					
	8.0	4.8	11.1	31.3	2.50	22.8	88.7	3.67	48.8	33.4	0.68	1.72	54.7	28.3
	11.0	7.5	17.2	30.4	2.44	22.1	88.1	3.65	49.5	34.1	0.69	1.62	55.0	30.6
40	5.0	2.1	4.9	Operation not recommended					Operation not recommended					
	8.0	4.8	11.1	35.1	2.62	26.2	91.2	3.93	49.5	34.0	0.69	1.93	56.1	25.6
	11.0	7.5	17.3	35.8	2.61	26.9	91.7	4.01	50.4	34.5	0.68	1.81	56.6	27.9
50	5.0	2.0	4.6	37.3	2.68	28.1	92.7	4.08	49.2	34.0	0.69	2.29	57.0	21.4
	8.0	4.7	10.9	39.2	2.73	29.9	93.9	4.20	50.2	34.5	0.69	2.15	57.6	23.4
	11.0	7.4	17.0	41.1	2.79	31.6	95.2	4.33	51.3	35.0	0.68	2.00	58.1	25.7
60	5.0	1.9	4.4	42.3	2.81	32.7	96.0	4.41	46.3	33.1	0.71	2.52	54.9	18.4
	8.0	4.6	10.5	44.2	2.86	34.4	97.2	4.53	47.4	33.5	0.71	2.38	55.5	19.9
	11.0	7.2	16.6	46.1	2.91	36.2	98.5	4.64	48.4	33.8	0.70	2.24	56.1	21.7
70	5.0	1.8	4.2	47.3	2.94	37.3	99.3	4.71	43.5	32.2	0.74	2.74	52.9	15.9
	8.0	4.5	10.4	49.2	2.99	39.0	100.5	4.82	44.5	32.4	0.73	2.61	53.4	17.1
	11.0	7.0	16.2	51.1	3.04	40.7	101.8	4.93	45.5	32.6	0.72	2.48	54.0	18.4
80	5.0	1.7	3.9	52.8	3.05	42.4	102.9	5.07	40.9	31.1	0.76	2.94	50.9	13.9
	8.0	4.5	10.4	54.1	3.09	43.6	103.8	5.13	41.7	31.3	0.75	2.81	51.2	14.8
	11.0	6.8	15.7	55.5	3.14	44.8	104.7	5.19	42.6	31.6	0.74	2.72	51.8	15.7
90	5.0	1.6	3.7	58.2	3.16	47.4	106.5	5.40	38.2	30.1	0.79	3.21	49.2	11.9
	8.0	4.4	10.2	59.1	3.20	48.2	107.1	5.42	38.8	30.3	0.78	3.06	49.3	12.7
	11.0	6.6	15.3	60.0	3.24	49.0	107.7	5.43	39.6	30.6	0.77	2.96	49.7	13.4
100	5.0	1.5	3.5	Operation not recommended					Operation not recommended					
	8.0	4.3	9.9						36.0	29.2	0.81	3.31	47.3	10.9
	11.0	6.2	14.3						36.6	29.4	0.80	3.20	47.5	11.4
110	5.0	1.4	3.2	Operation not recommended					Operation not recommended					
	8.0	4.2	9.7						32.9	27.8	0.84	3.53	44.9	9.3
	11.0	6.1	14.2						33.6	28.2	0.84	3.44	45.3	9.8
120	5.0	1.4	3.2	Operation not recommended					Operation not recommended					
	8.0	4.2	9.7						30.2	25.8	0.86	3.76	43.0	8.0
	11.0	6.1	14.1						30.8	26.2	0.85	3.65	43.3	8.4

9/18/11

The manufacturer works continually to improve its products. As a result, the design and specifications of each product at the time of order may be changed without notice. Purchaser's approval of this data set signifies that the equipment is acceptable under the provisions of the job specification. Statements and other information contained herein are not express warranties and do not form the basis of any bargain between the parties, but are merely the manufacturer's opinion or commendation of its products.

Contractor: \_\_\_\_\_ P.O.: \_\_\_\_\_

Engineer: \_\_\_\_\_

Project Name: \_\_\_\_\_ Unit Tag: \_\_\_\_\_



## ZB048 - Performance Data

### Single Speed with PSC (1600 CFM)

EWT °F	Flow GPM	WPD		HEATING - EAT 70°F					COOLING - EAT 80/67°F					
		psi	ft	HC MBtu/h	Power kW	HE MBtu/h	LAT °F	COP	TC MBtu/h	SC MBtu/h	S/T Ratio	Power kW	HR MBtu/h	EER
20	6.0	2.8	6.5	Operation not recommended					Operation not recommended					
	9.0	6.1	14.1											
	12.0	10.4	24.1	31.2	2.86	21.5	86.1	3.20						
30	6.0	2.7	6.2	Operation not recommended					Operation not recommended					
	9.0	6.0	13.9	36.6	3.00	26.3	89.2	3.57	56.2	38.3	0.68	2.26	63.9	24.8
	12.0	9.5	22.0	36.3	3.05	25.9	89.0	3.49	56.9	39.1	0.69	2.13	64.2	26.8
40	6.0	2.7	6.2	Operation not recommended					Operation not recommended					
	9.0	6.0	13.9	41.5	3.19	30.6	92.0	3.81	58.1	39.5	0.68	2.51	66.7	23.1
	12.0	9.4	21.7	42.6	3.26	31.5	92.7	3.84	58.9	40.0	0.68	2.36	67.0	24.9
50	6.0	2.6	6.0	45.0	3.33	33.7	94.1	3.96	59.2	40.4	0.68	2.92	69.2	20.3
	9.0	5.9	13.6	47.0	3.39	35.4	95.2	4.06	60.0	40.7	0.68	2.76	69.5	21.7
	12.0	9.3	21.4	48.9	3.46	37.1	96.3	4.14	60.9	41.0	0.67	2.60	69.7	23.4
60	6.0	2.5	5.8	51.3	3.54	39.2	97.7	4.25	56.1	38.9	0.69	3.19	67.0	17.6
	9.0	5.8	13.4	53.7	3.61	41.3	99.1	4.35	57.1	39.2	0.69	3.03	67.4	18.8
	12.0	9.2	21.3	56.0	3.69	43.5	100.4	4.45	58.0	39.5	0.68	2.88	67.9	20.1
70	6.0	2.4	5.5	57.6	3.76	44.8	101.4	4.50	53.0	37.4	0.70	3.45	64.8	15.4
	9.0	5.4	12.5	60.4	3.84	47.3	103.0	4.62	54.1	37.7	0.70	3.31	65.4	16.4
	12.0	8.5	19.6	63.2	3.92	49.8	104.6	4.73	55.2	38.0	0.69	3.16	66.0	17.5
80	6.0	2.3	5.3	65.0	3.97	51.4	105.6	4.79	49.4	36.0	0.73	3.73	62.1	13.2
	9.0	5.3	12.2	66.9	4.04	53.1	106.7	4.85	50.3	36.3	0.72	3.56	62.4	14.1
	12.0	8.4	19.4	68.8	4.11	54.8	107.8	4.91	51.3	36.6	0.71	3.44	63.1	14.9
90	6.0	2.2	5.1	72.3	4.19	58.0	109.8	5.06	45.8	34.7	0.76	4.04	59.5	11.3
	9.0	5.2	12.0	73.4	4.25	58.9	110.5	5.07	46.5	34.9	0.75	3.85	59.6	12.1
	12.0	8.3	19.2	74.5	4.30	59.9	111.1	5.08	47.4	35.2	0.74	3.73	60.1	12.7
100	6.0	2.1	4.9	Operation not recommended					Operation not recommended					
	9.0	5.2	12.0						42.8	33.1	0.77	4.12	56.8	10.4
	12.0	8.2	18.9						43.4	33.4	0.77	3.98	57.0	10.9
110	6.0	2.0	4.6	Operation not recommended					Operation not recommended					
	9.0	5.1	11.8						38.6	31.1	0.81	4.36	53.5	8.9
	12.0	8.1	18.8						39.4	31.6	0.80	4.24	53.9	9.3
120	6.0	1.9	4.4	Operation not recommended					Operation not recommended					
	9.0	5.0	11.6						34.7	29.4	0.85	4.61	50.4	7.5
	12.0	8.0	18.5						35.4	29.9	0.84	4.48	50.7	7.9

5/1/11

The manufacturer works continually to improve its products. As a result, the design and specifications of each product at the time of order may be changed without notice. Purchaser's approval of this data set signifies that the equipment is acceptable under the provisions of the job specification. Statements and other information contained herein are not express warranties and do not form the basis of any bargain between the parties, but are merely the manufacturer's opinion or commendation of its products.

Contractor: \_\_\_\_\_ P.O.: \_\_\_\_\_

Engineer: \_\_\_\_\_

Project Name: \_\_\_\_\_ Unit Tag: \_\_\_\_\_



## ZB060 - Performance Data

### Single Speed with PSC (2000 CFM)

EWT °F	Flow GPM	WPD		HEATING - EAT 70°F					COOLING - EAT 80/67°F					
		psi	ft	HC MBtu/h	Power kW	HE MBtu/h	LAT °F	COP	TC MBtu/h	SC MBtu/h	S/T Ratio	Power kW	HR MBtu/h	EER
20	9.0	4.6	10.6	Operation not recommended					Operation not recommended					
	12.0	7.3	16.9											
	15.0	10.0	23.1	35.5	3.50	23.5	85.3	2.97						
30	9.0	4.5	10.4	Operation not recommended					Operation not recommended					
	12.0	6.5	15.0	41.2	3.64	28.8	88.1	3.32	64.9	42.4	0.65	2.66	74.0	24.4
	15.0	8.6	19.8	41.2	3.69	28.6	88.1	3.27	65.8	43.3	0.66	2.50	74.3	26.3
40	9.0	4.5	10.4	Operation not recommended					Operation not recommended					
	12.0	6.5	15.0	46.4	3.90	33.1	90.6	3.49	66.2	44.3	0.67	2.93	76.2	22.6
	15.0	8.6	19.9	47.5	3.96	34.0	91.1	3.51	67.0	44.7	0.67	2.79	76.5	24.0
50	9.0	4.4	10.0	50.6	4.10	36.7	92.7	3.62	66.8	46.2	0.69	3.31	78.1	20.2
	12.0	6.3	14.4	52.2	4.16	38.0	93.4	3.67	67.5	46.1	0.68	3.20	78.4	21.1
	15.0	8.1	18.8	53.7	4.23	39.3	94.2	3.72	68.1	46.1	0.68	3.09	78.6	22.1
60	9.0	4.3	9.9	56.8	4.37	41.9	95.7	3.81	63.5	45.0	0.71	3.63	75.9	17.5
	12.0	6.2	14.3	59.2	4.46	43.9	96.8	3.89	64.2	45.0	0.70	3.53	76.2	18.2
	15.0	8.0	18.5	61.5	4.56	46.0	98.0	3.96	64.9	45.1	0.70	3.42	76.5	19.0
70	9.0	4.2	9.6	63.0	4.63	47.2	98.7	3.98	60.3	43.7	0.73	3.96	73.7	15.2
	12.0	6.1	14.1	66.1	4.76	49.9	100.2	4.07	60.9	43.9	0.72	3.85	74.1	15.8
	15.0	7.9	18.2	69.3	4.89	52.6	101.8	4.16	61.6	44.1	0.72	3.75	74.4	16.4
80	9.0	4.1	9.5	70.6	4.91	53.9	102.4	4.22	56.2	41.8	0.74	4.44	71.4	12.7
	12.0	6.0	13.9	72.8	5.00	55.8	103.5	4.27	57.0	42.1	0.74	4.24	71.4	13.4
	15.0	7.8	18.0	75.0	5.10	57.6	104.6	4.31	57.9	42.3	0.73	4.10	71.8	14.1
90	9.0	4.0	9.2	78.3	5.18	60.6	106.2	4.43	52.2	39.9	0.76	4.82	68.6	10.8
	12.0	5.9	13.6	79.5	5.25	61.6	106.7	4.44	53.0	40.2	0.76	4.60	68.7	11.5
	15.0	7.7	17.8	80.7	5.31	62.6	107.3	4.45	54.1	40.5	0.75	4.45	69.2	12.2
100	9.0	3.9	9.0	Operation not recommended					Operation not recommended					
	12.0	5.8	13.4						48.8	38.5	0.79	4.96	65.7	9.8
	15.0	7.6	17.6						49.5	38.8	0.78	4.80	65.9	10.3
110	9.0	3.8	8.8	Operation not recommended					Operation not recommended					
	12.0	5.7	13.2						44.1	36.5	0.83	5.31	62.2	8.3
	15.0	7.5	17.3						45.0	37.1	0.82	5.16	62.6	8.7
120	9.0	3.7	8.5	Operation not recommended					Operation not recommended					
	12.0	5.6	12.9						39.7	34.6	0.87	5.68	59.1	7.0
	15.0	7.4	17.1						40.6	35.1	0.86	5.51	59.4	7.4

5/1/11

The manufacturer works continually to improve its products. As a result, the design and specifications of each product at the time of order may be changed without notice. Purchaser's approval of this data set signifies that the equipment is acceptable under the provisions of the job specification. Statements and other information contained herein are not express warranties and do not form the basis of any bargain between the parties, but are merely the manufacturer's opinion or commendation of its products.



Contractor: \_\_\_\_\_ P.O.: \_\_\_\_\_

Engineer: \_\_\_\_\_

Project Name: \_\_\_\_\_ Unit Tag: \_\_\_\_\_



## ZB070 - Performance Data

### Single Speed with PSC (2200 CFM)

EWT °F	Flow GPM	WPD		HEATING - EAT 70°F					COOLING - EAT 80/67°F					
		psi	ft	HC MBtu/h	Power kW	HE MBtu/h	LAT °F	COP	TC MBtu/h	SC MBtu/h	S/T Ratio	Power kW	HR MBtu/h	EER
20	12.0	5.8	13.4	Operation not recommended					Operation not recommended					
	15.0	9.1	20.9											
	18.0	12.3	28.4	42.5	3.90	29.2	86.7	3.20						
30	12.0	5.7	13.2	Operation not recommended					Operation not recommended					
	15.0	8.9	20.4	50.2	4.15	36.0	90.1	3.54	66.2	41.5	0.63	2.90	76.1	22.8
	18.0	12.0	27.7	48.6	4.15	34.5	89.4	3.43	67.1	42.4	0.63	2.73	76.4	24.6
40	12.0	5.7	13.2	Operation not recommended					Operation not recommended					
	15.0	8.9	20.4	56.9	4.37	42.0	93.1	3.81	71.3	46.6	0.65	3.16	82.0	22.6
	18.0	12.0	27.7	57.0	4.39	42.0	93.1	3.81	71.4	46.5	0.65	3.03	81.8	23.6
50	12.0	5.6	13.0	63.3	4.57	47.7	95.9	4.06	76.8	52.6	0.68	3.50	88.8	21.9
	15.0	8.6	19.8	64.3	4.60	48.7	96.4	4.10	76.3	51.6	0.68	3.41	87.9	22.4
	18.0	11.5	26.6	65.4	4.63	49.6	96.8	4.14	75.7	50.6	0.67	3.33	87.1	22.8
60	12.0	5.5	12.7	72.1	4.81	55.7	99.8	4.40	74.2	52.2	0.70	3.88	87.4	19.1
	15.0	8.4	19.3	73.6	4.85	57.0	100.4	4.45	74.2	51.7	0.70	3.79	87.1	19.6
	18.0	11.2	25.9	75.0	4.88	58.3	101.1	4.50	74.2	51.3	0.69	3.70	86.8	20.0
70	12.0	5.4	12.5	80.9	5.05	63.7	103.7	4.70	71.5	51.8	0.72	4.26	86.1	16.8
	15.0	8.2	18.9	82.8	5.09	65.4	104.5	4.76	72.1	51.9	0.72	4.17	86.3	17.3
	18.0	11.0	25.5	84.6	5.14	67.1	105.3	4.83	72.6	51.9	0.72	4.08	86.5	17.8
80	12.0	5.3	12.2	88.9	5.23	71.1	107.2	4.99	66.5	50.2	0.76	4.86	83.0	13.7
	15.0	7.9	18.2	90.6	5.28	72.5	107.9	5.02	67.2	50.3	0.75	4.63	83.0	14.5
	18.0	10.5	24.3	92.2	5.34	74.0	108.7	5.06	68.1	50.5	0.74	4.48	83.4	15.2
90	12.0	5.2	12.0	96.9	5.40	78.4	110.7	5.26	61.4	48.6	0.79	5.30	79.5	11.6
	15.0	7.7	17.7	98.4	5.47	79.7	111.4	5.27	62.3	48.8	0.78	5.05	79.6	12.3
	18.0	10.1	23.4	99.9	5.54	81.0	112.0	5.28	63.6	49.1	0.77	4.89	80.3	13.0
100	12.0	5.1	11.8	Operation not recommended					Operation not recommended					
	15.0	7.3	16.7						57.6	46.3	0.80	5.45	76.2	10.6
	18.0	9.4	21.7						58.5	46.7	0.80	5.27	76.4	11.1
110	12.0	5.0	11.6						Operation not recommended					
	15.0	6.7	15.5						52.3	43.7	0.84	5.81	72.1	9.0
	18.0	8.4	19.5						53.3	44.4	0.83	5.65	72.6	9.4
120	12.0	4.9	11.3						Operation not recommended					
	15.0	6.6	15.2						47.5	41.8	0.88	6.21	68.7	7.6
	18.0	8.3	19.1						48.5	42.4	0.87	6.03	69.1	8.0

5/1/11

The manufacturer works continually to improve its products. As a result, the design and specifications of each product at the time of order may be changed without notice. Purchaser's approval of this data set signifies that the equipment is acceptable under the provisions of the job specification. Statements and other information contained herein are not express warranties and do not form the basis of any bargain between the parties, but are merely the manufacturer's opinion or commendation of its products.

Contractor: \_\_\_\_\_ P.O.: \_\_\_\_\_

Engineer: \_\_\_\_\_

Project Name: \_\_\_\_\_ Unit Tag: \_\_\_\_\_



## ZB015 - Performance Data

### Single Speed with Variable Speed ECM or 5-Speed ECM (500 CFM)

EWT °F	Flow GPM	WPD		HEATING - EAT 70°F					COOLING - EAT 80/67°F					
		psi	ft	HC MBtu/h	Power kW	HE MBtu/h	LAT °F	COP	TC MBtu/h	SC MBtu/h	S/T Ratio	Power kW	HR MBtu/h	EER
20	2.0	1.9	4.4	Operation not recommended					Operation not recommended					
	3.0	3.4	7.9	Operation not recommended					Operation not recommended					
	4.0	5.1	11.7	9.2	0.95	5.9	85.0	2.82	Operation not recommended					
30	2.0	1.8	4.2	Operation not recommended					Operation not recommended					
	3.0	3.3	7.6	11.2	0.99	7.8	88.8	3.32	16.9	11.6	0.68	0.64	19.1	26.4
	4.0	5.0	11.5	10.7	1.00	7.3	87.9	3.15	17.1	11.8	0.69	0.60	19.2	28.5
40	2.0	1.8	4.2	Operation not recommended					Operation not recommended					
	3.0	3.2	7.4	12.2	1.01	8.7	90.6	3.53	16.6	11.6	0.70	0.69	18.9	24.0
	4.0	5.0	11.6	12.1	1.02	8.7	90.5	3.49	16.8	11.7	0.70	0.66	19.0	25.6
50	2.0	1.7	3.9	12.9	1.02	9.4	91.8	3.70	16.1	11.5	0.72	0.78	18.7	20.6
	3.0	3.1	7.2	13.2	1.03	9.7	92.5	3.76	16.3	11.6	0.71	0.75	18.8	21.8
	4.0	4.9	11.3	13.5	1.04	10.0	93.1	3.82	16.5	11.7	0.71	0.71	18.9	23.2
60	2.0	1.6	3.7	14.1	1.04	10.5	94.0	3.96	15.3	11.1	0.72	1.38	20.0	11.1
	3.0	3.0	6.9	14.4	1.05	10.8	94.6	4.02	15.5	11.2	0.72	1.09	19.2	14.2
	4.0	4.9	11.3	14.7	1.06	11.1	95.2	4.07	15.7	11.3	0.72	0.80	18.5	19.7
70	2.0	1.6	3.6	15.3	1.06	11.6	96.3	4.22	14.5	10.6	0.73	1.98	21.3	7.3
	3.0	2.9	6.7	15.6	1.07	11.9	96.8	4.26	14.8	10.8	0.73	1.44	19.7	10.3
	4.0	4.8	11.1	15.9	1.08	12.2	97.4	4.31	15.0	10.9	0.72	0.89	18.0	16.9
80	2.0	1.5	3.5	16.2	1.07	12.6	98.1	4.46	13.7	10.2	0.75	1.07	17.3	12.8
	3.0	2.8	6.5	16.5	1.08	12.8	98.6	4.49	13.9	10.4	0.75	1.02	17.4	13.7
	4.0	4.8	11.1	16.8	1.09	13.1	99.1	4.52	14.2	10.5	0.74	0.99	17.5	14.4
90	2.0	1.4	3.2	17.2	1.07	13.6	99.9	4.70	12.9	9.8	0.76	1.17	16.8	11.0
	3.0	2.6	6.0	17.5	1.09	13.8	100.4	4.72	13.1	10.0	0.77	1.12	16.9	11.7
	4.0	4.7	10.9	17.7	1.10	14.0	100.9	4.73	13.3	10.1	0.76	1.08	17.0	12.3
100	2.0	1.3	3.0	Operation not recommended					Operation not recommended					
	3.0	2.4	5.5						12.0	9.5	0.80	1.22	16.1	9.8
	4.0	4.6	10.6						12.1	9.6	0.79	1.19	16.2	10.2
110	2.0	1.2	2.8	Operation not recommended					Operation not recommended					
	3.0	2.3	5.3						10.7	9.0	0.84	1.33	15.3	8.1
	4.0	4.6	10.6						11.0	9.2	0.84	1.29	15.4	8.5
120	2.0	1.1	2.5	Operation not recommended					Operation not recommended					
	3.0	2.2	5.1						9.2	8.5	0.92	1.46	14.2	6.3
	4.0	4.5	10.4						9.4	8.7	0.92	1.42	14.3	6.6

9/5/2012

The manufacturer works continually to improve its products. As a result, the design and specifications of each product at the time of order may be changed without notice. Purchaser's approval of this data set signifies that the equipment is acceptable under the provisions of the job specification. Statements and other information contained herein are not express warranties and do not form the basis of any bargain between the parties, but are merely the manufacturer's opinion or commendation of its products.

Contractor: \_\_\_\_\_ P.O.: \_\_\_\_\_

Engineer: \_\_\_\_\_

Project Name: \_\_\_\_\_ Unit Tag: \_\_\_\_\_



## ZB018 - Performance Data

### Single Speed with Variable Speed ECM or 5-Speed ECM (600 CFM)

EWT °F	Flow GPM	WPD		HEATING - EAT 70°F					COOLING - EAT 80/67°F					
		psi	ft	HC MBtu/h	Power kW	HE MBtu/h	LAT °F	COP	TC MBtu/h	SC MBtu/h	S/T Ratio	Power kW	HR MBtu/h	EER
20	3.0	3.4	7.9	Operation not recommended					Operation not recommended					
	4.0	4.9	11.3											
	5.0	6.5	15.0	11.7	1.24	7.5	86.1	2.78						
30	3.0	3.3	7.6	Operation not recommended					Operation not recommended					
	4.0	4.7	10.9	13.8	1.31	9.4	89.3	3.10	22.1	14.5	0.66	0.71	24.5	31.4
	5.0	6.2	14.2	13.5	1.28	9.1	88.8	3.08	22.4	14.8	0.66	0.66	24.7	33.9
40	3.0	3.3	7.6	Operation not recommended					Operation not recommended					
	4.0	4.7	10.9	15.1	1.33	10.6	91.3	3.33	21.9	14.4	0.66	0.84	24.7	26.2
	5.0	6.2	14.3	15.1	1.31	10.6	91.3	3.37	21.9	14.5	0.66	0.80	24.7	27.3
50	3.0	3.2	7.4	16.2	1.36	11.6	93.0	3.49	21.8	14.4	0.66	0.99	25.2	22.0
	4.0	4.2	9.7	16.5	1.35	11.8	93.4	3.57	21.6	14.3	0.66	0.97	24.9	22.4
	5.0	5.2	11.9	16.7	1.34	12.1	93.8	3.65	21.4	14.3	0.67	0.94	24.6	22.7
60	3.0	3.1	7.2	17.9	1.38	13.2	95.5	3.80	20.7	13.9	0.67	1.11	24.5	18.6
	4.0	4.1	9.4	18.0	1.38	13.4	95.9	3.85	20.5	13.9	0.68	1.08	24.2	18.9
	5.0	5.0	11.6	18.2	1.38	13.6	96.2	3.89	20.2	13.8	0.68	1.06	23.9	19.1
70	3.0	3.0	6.9	19.5	1.39	14.8	98.1	4.11	19.6	13.5	0.69	1.23	23.8	15.9
	4.0	3.9	8.9	19.6	1.40	14.9	98.3	4.11	19.3	13.4	0.69	1.20	23.4	16.1
	5.0	4.7	10.9	19.8	1.41	15.0	98.5	4.12	19.1	13.3	0.70	1.18	23.1	16.2
80	3.0	2.9	6.7	20.3	1.39	15.6	99.4	4.28	18.4	12.8	0.70	1.42	23.2	13.0
	4.0	3.7	8.4	20.6	1.41	15.8	99.8	4.29	18.4	12.9	0.70	1.35	23.0	13.6
	5.0	4.4	10.2	20.8	1.42	16.0	100.1	4.30	18.4	12.9	0.70	1.31	22.9	14.1
90	3.0	2.8	6.5	21.2	1.39	16.4	100.7	4.46	17.1	12.2	0.71	1.56	22.5	11.0
	4.0	3.6	8.3	21.5	1.41	16.7	101.2	4.47	17.4	12.4	0.71	1.49	22.5	11.7
	5.0	4.1	9.5	21.9	1.43	17.0	101.7	4.48	17.8	12.6	0.71	1.44	22.7	12.3
100	3.0	2.7	6.2	Operation not recommended					Operation not recommended					
	4.0	3.5	8.1						16.6	12.0	0.72	1.62	22.1	10.2
	5.0	3.9	9.0						16.8	12.1	0.72	1.57	22.2	10.7
110	3.0	2.6	6.0	Operation not recommended					Operation not recommended					
	4.0	3.1	7.0						15.5	11.4	0.73	1.74	21.5	8.9
	5.0	3.5	8.1						15.8	11.5	0.73	1.70	21.6	9.3
120	3.0	2.5	5.8	Operation not recommended					Operation not recommended					
	4.0	3.0	6.9						13.1	9.8	0.74	1.91	19.6	6.9
	5.0	3.4	7.9						13.4	9.9	0.74	1.85	19.7	7.2

5/1/11

The manufacturer works continually to improve its products. As a result, the design and specifications of each product at the time of order may be changed without notice. Purchaser's approval of this data set signifies that the equipment is acceptable under the provisions of the job specification. Statements and other information contained herein are not express warranties and do not form the basis of any bargain between the parties, but are merely the manufacturer's opinion or commendation of its products.

Contractor: \_\_\_\_\_ P.O.: \_\_\_\_\_

Engineer: \_\_\_\_\_

Project Name: \_\_\_\_\_ Unit Tag: \_\_\_\_\_

**Arbor Base Series Commercial  
Geothermal/Water Source Heat Pumps  
0.5-6 Tons, 60Hz**



## ZB024 - Performance Data

### Single Speed with Variable Speed ECM or 5-Speed ECM (800 CFM)

EWT °F	Flow GPM	WPD		HEATING - EAT 70°F					COOLING - EAT 80/67°F					
		psi	ft	HC MBtu/h	Power kW	HE MBtu/h	LAT °F	COP	TC MBtu/h	SC MBtu/h	S/T Ratio	Power kW	HR MBtu/h	EER
20	3.0	3.3	7.6	Operation not recommended					Operation not recommended					
	4.5	7.0	16.1											
	6.0	10.6	24.4	13.8	1.21	9.7	84.0	3.35						
30	3.0	3.2	7.4	Operation not recommended					Operation not recommended					
	4.5	6.1	14.1	18.7	1.40	13.9	89.6	3.92	29.3	19.6	0.67	0.99	32.7	29.8
	6.0	9.0	20.8	16.8	1.33	12.3	87.4	3.70	29.7	20.0	0.67	0.93	32.9	32.1
40	3.0	3.2	7.4	Operation not recommended					Operation not recommended					
	4.5	6.1	14.1	20.3	1.46	15.4	91.5	4.10	28.8	19.5	0.68	1.18	32.9	24.5
	6.0	9.0	20.8	19.8	1.44	14.9	91.0	4.05	29.4	19.8	0.68	1.17	33.3	25.2
50	3.0	3.1	7.1	21.4	1.49	16.3	92.7	4.20	27.7	19.3	0.70	1.34	32.2	20.7
	4.5	5.5	12.7	22.1	1.52	16.9	93.6	4.28	28.3	19.5	0.69	1.37	33.0	20.7
	6.0	7.9	18.2	22.9	1.54	17.6	94.5	4.35	29.0	19.7	0.68	1.41	33.8	20.6
60	3.0	3.0	6.9	23.8	1.56	18.4	95.5	4.46	26.3	18.5	0.70	1.47	31.3	17.9
	4.5	5.3	12.1	24.2	1.58	18.8	96.0	4.48	27.0	18.8	0.70	1.46	31.9	18.5
	6.0	7.5	17.3	24.6	1.60	19.1	96.4	4.50	27.6	19.1	0.69	1.44	32.5	19.2
70	3.0	2.9	6.7	26.2	1.63	20.6	98.3	4.70	24.9	17.7	0.71	1.61	30.4	15.5
	4.5	4.9	11.3	26.2	1.64	20.6	98.3	4.67	25.6	18.1	0.71	1.54	30.9	16.6
	6.0	6.9	16.0	26.3	1.66	20.6	98.4	4.64	26.3	18.4	0.70	1.48	31.3	17.8
80	3.0	2.8	6.5	27.4	1.65	21.8	99.7	4.86	23.4	17.2	0.74	1.76	29.4	13.3
	4.5	4.7	10.7	27.6	1.67	21.9	100.0	4.85	23.9	17.5	0.73	1.68	29.6	14.2
	6.0	6.5	15.0	27.9	1.69	22.1	100.3	4.84	24.4	17.8	0.73	1.62	30.0	15.1
90	3.0	2.7	6.2	28.6	1.68	22.9	101.1	5.00	21.8	16.7	0.77	1.92	28.4	11.4
	4.5	4.5	10.4	29.1	1.70	23.3	101.7	5.02	22.2	16.9	0.76	1.83	28.4	12.1
	6.0	6.3	14.5	29.5	1.72	23.7	102.2	5.03	22.6	17.2	0.76	1.77	28.6	12.8
100	3.0	2.6	6.0	Operation not recommended					Operation not recommended					
	4.5	4.3	9.9						20.4	16.2	0.79	1.97	27.2	10.3
	6.0	6.0	13.9						20.7	16.3	0.79	1.91	27.3	10.9
110	3.0	2.5	5.8	Operation not recommended					Operation not recommended					
	4.5	4.2	9.6						18.5	15.3	0.83	2.11	25.7	8.8
	6.0	5.8	13.4						18.9	15.5	0.82	2.05	25.9	9.2
120	3.0	2.4	5.5	Operation not recommended					Operation not recommended					
	4.5	4.0	9.2						16.1	13.8	0.86	2.26	23.8	7.1
	6.0	5.6	13.0						16.4	14.0	0.85	2.19	23.9	7.5

5/1/11

The manufacturer works continually to improve its products. As a result, the design and specifications of each product at the time of order may be changed without notice. Purchaser's approval of this data set signifies that the equipment is acceptable under the provisions of the job specification. Statements and other information contained herein are not express warranties and do not form the basis of any bargain between the parties, but are merely the manufacturer's opinion or commendation of its products.

Contractor: \_\_\_\_\_ P.O.: \_\_\_\_\_

Engineer: \_\_\_\_\_

Project Name: \_\_\_\_\_ Unit Tag: \_\_\_\_\_



## ZB030 - Performance Data

### Single Speed with Variable Speed ECM or 5-Speed ECM (1000 CFM)

EWT °F	Flow GPM	WPD		HEATING - EAT 70°F					COOLING - EAT 80/67°F					
		psi	ft	HC MBtu/h	Power kW	HE MBtu/h	LAT °F	COP	TC MBtu/h	SC MBtu/h	S/T Ratio	Power kW	HR MBtu/h	EER
20	8.0	2.5	5.8	Operation not recommended					Operation not recommended					
	4.0	5.2	12.0	Operation not recommended					Operation not recommended					
	6.0	7.9	18.3	16.8	1.46	11.9	83.6	3.39	Operation not recommended					
30	8.0	2.4	5.5	Operation not recommended					Operation not recommended					
	4.0	5.1	11.8	22.2	1.63	16.6	88.5	3.99	35.0	23.1	0.66	1.03	38.5	34.1
	6.0	7.8	18.0	20.5	1.60	15.0	87.0	3.76	35.5	23.6	0.66	0.96	38.8	36.8
40	8.0	2.3	5.3	Operation not recommended					Operation not recommended					
	4.0	4.9	11.3	24.7	1.72	18.8	90.8	4.21	35.1	23.6	0.67	1.18	39.2	29.8
	6.0	7.5	17.3	24.4	1.72	18.5	90.6	4.16	35.8	24.0	0.67	1.10	39.5	32.4
50	4.0	2.3	5.3	26.5	1.79	20.4	92.5	4.34	34.6	23.8	0.69	1.43	39.4	24.2
	6.0	4.9	11.3	27.4	1.81	21.2	93.4	4.43	35.3	24.1	0.68	1.33	39.8	26.4
	8.0	7.5	17.2	28.3	1.84	22.0	94.2	4.51	36.0	24.4	0.68	1.24	40.3	29.1
60	8.0	2.2	5.1	29.6	1.88	23.1	95.4	4.60	32.7	22.9	0.70	1.60	38.2	20.5
	4.0	4.7	10.9	30.6	1.91	24.1	96.4	4.69	34.3	23.8	0.69	1.39	39.1	24.7
	6.0	7.1	16.4	31.7	1.94	25.1	97.3	4.78	34.1	23.5	0.69	1.42	38.9	23.9
70	8.0	2.2	5.0	32.7	1.98	25.9	98.2	4.84	30.9	22.0	0.71	1.77	37.0	17.5
	4.0	4.7	10.9	33.9	2.01	27.0	99.4	4.93	33.3	23.5	0.70	1.45	38.3	23.1
	6.0	7.1	16.4	35.1	2.05	28.1	100.5	5.01	32.1	22.7	0.71	1.61	37.6	20.0
80	8.0	2.1	4.9	35.7	2.05	28.7	101.0	5.10	29.0	21.2	0.73	1.93	35.6	15.0
	4.0	4.6	10.6	36.6	2.08	29.5	101.9	5.15	30.4	22.0	0.72	1.84	36.7	16.5
	6.0	7.0	16.2	37.5	2.11	30.3	102.7	5.20	30.1	21.8	0.72	1.78	36.2	16.9
90	8.0	2.0	4.6	38.7	2.12	31.5	103.8	5.35	27.0	20.4	0.75	2.12	34.3	12.8
	4.0	4.5	10.4	39.3	2.15	32.0	104.4	5.37	27.5	20.6	0.75	2.02	34.4	13.6
	6.0	6.9	16.0	39.9	2.17	32.5	105.0	5.38	28.0	20.8	0.74	1.96	34.7	14.3
100	8.0	1.9	4.4	Operation not recommended					Operation not recommended					
	4.0	4.4	10.2	Operation not recommended					25.3	19.6	0.77	2.20	32.8	11.5
	6.0	6.8	15.7	Operation not recommended					25.7	19.8	0.77	2.13	32.9	12.1
110	8.0	1.8	4.2	Operation not recommended					Operation not recommended					
	4.0	4.3	9.9	Operation not recommended					22.9	18.4	0.80	2.36	30.9	9.7
	6.0	6.7	15.5	Operation not recommended					23.3	18.7	0.80	2.29	31.2	10.2
120	8.0	1.7	3.9	Operation not recommended					Operation not recommended					
	4.0	4.2	9.7	Operation not recommended					20.0	16.8	0.84	2.53	28.7	7.9
	6.0	6.6	15.2	Operation not recommended					20.5	17.1	0.84	2.46	28.9	8.3

5/1/11

The manufacturer works continually to improve its products. As a result, the design and specifications of each product at the time of order may be changed without notice. Purchaser's approval of this data set signifies that the equipment is acceptable under the provisions of the job specification. Statements and other information contained herein are not express warranties and do not form the basis of any bargain between the parties, but are merely the manufacturer's opinion or commendation of its products.

Contractor: \_\_\_\_\_ P.O.: \_\_\_\_\_

Engineer: \_\_\_\_\_

Project Name: \_\_\_\_\_ Unit Tag: \_\_\_\_\_



## ZB036 - Performance Data

### Single Speed with Variable Speed ECM or 5-Speed ECM (1150 CFM)

EWT °F	Flow GPM	WPD		HEATING - EAT 70°F					COOLING - EAT 80/67°F					
		psi	ft	HC MBtu/h	Power kW	HE MBtu/h	LAT °F	COP	TC MBtu/h	SC MBtu/h	S/T Ratio	Power kW	HR MBtu/h	EER
20	5.0	2.1	4.9	Operation not recommended					Operation not recommended					
	7.0	3.7	8.5	Operation not recommended					Operation not recommended					
	9.0	5.3	12.2	22.3	1.95	15.6	86.0	3.35	Operation not recommended					
30	5.0	2.0	4.6	Operation not recommended					Operation not recommended					
	7.0	3.6	8.3	27.3	2.12	20.1	90.0	3.77	41.8	26.6	0.64	1.42	46.6	29.5
	9.0	5.2	12.0	25.6	2.07	18.5	88.6	3.62	42.4	27.1	0.64	1.33	46.9	31.8
40	5.0	2.0	4.6	Operation not recommended					Operation not recommended					
	7.0	3.6	8.3	30.5	2.23	22.9	92.6	4.01	42.2	27.6	0.65	1.60	47.6	26.4
	9.0	5.2	12.0	30.4	2.23	22.8	92.5	4.00	42.7	27.9	0.65	1.51	47.8	28.3
50	5.0	1.9	4.4	32.7	2.30	24.9	94.3	4.17	42.2	28.4	0.67	1.87	48.6	22.6
	7.0	3.5	8.1	34.0	2.35	26.0	95.4	4.25	42.6	28.5	0.67	1.78	48.7	23.9
	9.0	5.1	11.7	35.2	2.39	27.1	96.4	4.32	43.0	28.6	0.66	1.69	48.8	25.5
60	5.0	1.8	4.2	36.9	2.43	28.6	97.7	4.45	40.4	27.9	0.69	2.08	47.5	19.4
	7.0	3.4	7.9	38.1	2.47	29.7	98.7	4.53	40.9	28.0	0.68	1.99	47.7	20.6
	9.0	5.0	11.6	39.4	2.51	30.9	99.7	4.61	41.4	28.1	0.68	1.90	47.9	21.8
70	5.0	1.7	3.9	41.1	2.56	32.3	101.1	4.70	38.6	27.3	0.71	2.29	46.4	16.8
	7.0	3.3	7.6	42.3	2.59	33.5	102.1	4.79	39.2	27.5	0.70	2.20	46.7	17.8
	9.0	4.8	11.1	43.6	2.62	34.6	103.1	4.87	39.9	27.6	0.69	2.11	47.1	18.9
80	5.0	1.6	3.7	44.3	2.66	35.2	103.7	4.88	36.0	26.1	0.72	2.53	44.6	14.2
	7.0	3.2	7.3	45.3	2.69	36.1	104.5	4.93	36.6	26.3	0.72	2.42	44.8	15.1
	9.0	4.7	10.9	46.3	2.73	37.0	105.3	4.98	37.3	26.5	0.71	2.34	45.2	15.9
90	5.0	1.5	3.5	47.5	2.76	38.1	106.3	5.05	33.4	24.8	0.74	2.78	42.9	12.0
	7.0	3.1	7.2	48.2	2.80	38.7	106.8	5.06	34.0	25.1	0.74	2.66	43.0	12.8
	9.0	4.6	10.6	49.0	2.83	39.3	107.4	5.07	34.7	25.4	0.73	2.57	43.4	13.5
100	5.0	1.5	3.5	Operation not recommended					Operation not recommended					
	7.0	3.1	7.2	Operation not recommended					31.5	24.3	0.77	2.87	41.3	11.0
	9.0	4.6	10.6	Operation not recommended					32.0	24.5	0.76	2.78	41.5	11.5
110	5.0	1.4	3.2	Operation not recommended					Operation not recommended					
	7.0	2.9	6.7	Operation not recommended					28.7	23.2	0.81	3.06	39.2	9.4
	9.0	4.4	10.0	Operation not recommended					29.3	23.5	0.80	2.98	39.5	9.8
120	5.0	1.3	3.0	Operation not recommended					Operation not recommended					
	7.0	2.8	6.5	Operation not recommended					26.0	22.1	0.85	3.29	37.3	7.9
	9.0	4.3	9.9	Operation not recommended					26.6	22.4	0.84	3.20	37.5	8.3

5/1/11

The manufacturer works continually to improve its products. As a result, the design and specifications of each product at the time of order may be changed without notice. Purchaser's approval of this data set signifies that the equipment is acceptable under the provisions of the job specification. Statements and other information contained herein are not express warranties and do not form the basis of any bargain between the parties, but are merely the manufacturer's opinion or commendation of its products.

Contractor: \_\_\_\_\_ P.O.: \_\_\_\_\_

Engineer: \_\_\_\_\_

Project Name: \_\_\_\_\_ Unit Tag: \_\_\_\_\_

**Arbor Base Series Commercial  
Geothermal/Water Source Heat Pumps  
0.5-6 Tons, 60Hz**



## ZB041 - Performance Data

### Single Speed with Variable Speed ECM or 5-Speed ECM (1300 cfm)

EWT °F	Flow GPM	WPD		HEATING - EAT 70°F					COOLING - EAT 80/67°F																
		psi	ft	HC MBtu/h	Power kW	HE MBtu/h	LAT °F	COP	TC MBtu/h	SC MBtu/h	S/T Ratio	Power kW	HR MBtu/h	EER											
20	5.0	1.6	3.8	Operation not recommended					Operation not recommended																
	8.0	3.6	8.2																						
	11.0	8.0	18.5												25.2	2.40	17.0	85.9	3.08						
30	5.0	1.5	3.4	Operation not recommended					Operation not recommended																
	8.0	3.4	7.8												30.9	2.58	22.0	90.0	3.50	45.1	31.7	0.70	1.81	51.3	24.9
	11.0	7.9	18.1												29.7	2.54	21.0	89.2	3.43	45.7	32.3	0.71	1.70	51.5	26.9
40	5.0	1.3	3.0	Operation not recommended					Operation not recommended																
	8.0	3.2	7.5												34.8	2.71	25.5	92.8	3.76	47.2	32.9	0.70	1.98	54.0	23.8
	11.0	7.7	17.8												35.3	2.73	26.0	93.1	3.79	47.8	33.3	0.70	1.86	54.1	25.8
50	5.0	1.2	2.7	Operation not recommended					Operation not recommended																
	8.0	3.1	7.1												37.5	2.80	27.9	94.7	3.93	48.7	33.8	0.69	2.30	56.5	21.2
	11.0	7.5	17.4												39.2	2.86	29.4	95.9	4.02	49.3	34.1	0.69	2.16	56.7	22.9
60	5.0	1.0	2.3	Operation not recommended					Operation not recommended																
	8.0	2.9	6.7												42.7	2.96	32.6	98.4	4.24	46.1	32.8	0.71	2.53	54.7	18.2
	11.0	7.4	17.0												44.5	3.01	34.2	99.7	4.33	46.8	33.1	0.71	2.39	55.0	19.6
70	5.0	0.9	2.0	Operation not recommended					Operation not recommended																
	8.0	2.8	6.4												46.3	3.06	35.8	100.9	4.43	47.6	33.4	0.70	2.26	55.3	21.1
	11.0	7.2	16.7												47.9	3.11	37.3	102.1	4.51	43.4	31.7	0.73	2.75	52.8	15.8
80	5.0	0.7	1.6	Operation not recommended					Operation not recommended																
	8.0	2.6	6.0												49.8	3.16	39.0	103.5	4.62	44.4	32.1	0.72	2.63	53.3	16.9
	11.0	7.1	16.3												51.7	3.21	40.7	104.8	4.72	45.3	32.4	0.72	2.50	53.8	18.1
90	5.0	0.7	1.6	Operation not recommended					Operation not recommended																
	8.0	2.6	6.0												53.5	3.23	42.5	106.1	4.85	40.9	30.8	0.75	2.97	51.0	13.8
	11.0	7.1	16.3												54.9	3.28	43.7	107.1	4.91	41.7	31.0	0.74	2.84	51.4	14.7
90	5.0	0.5	1.2	Operation not recommended					Operation not recommended																
	8.0	2.5	5.7												56.3	3.33	45.0	108.1	4.96	42.6	31.3	0.74	2.75	51.9	15.5
	11.0	6.9	16.0												59.1	3.35	47.6	110.1	5.16	38.4	29.8	0.78	3.24	49.5	11.9
90	5.0	0.5	1.2	Operation not recommended					Operation not recommended																
	8.0	2.5	5.7												60.0	3.40	48.4	110.7	5.17	39.0	29.9	0.77	3.09	49.5	12.6
	11.0	6.9	16.0												60.9	3.44	49.2	111.4	5.19	39.8	30.2	0.76	2.99	50.0	13.3
100	5.0	0.4	0.9	Operation not recommended					Operation not recommended																
	8.0	2.3	5.3												36.2	28.7	0.79	3.34	47.6	10.8					
	11.0	6.8	15.6												36.8	29.0	0.79	3.23	47.8	11.4					
110	5.0	0.4	0.9	Operation not recommended					Operation not recommended																
	8.0	2.1	4.9												33.0	27.3	0.83	3.57	45.2	9.3					
	11.0	6.6	15.2												33.7	27.7	0.82	3.47	45.5	9.7					
120	5.0	0.4	0.9	Operation not recommended					Operation not recommended																
	8.0	2.0	4.6												29.8	26.2	0.88	3.82	42.8	7.8					
	11.0	6.5	14.9												30.4	26.6	0.88	3.71	43.1	8.2					

10/15/15

The manufacturer works continually to improve its products. As a result, the design and specifications of each product at the time of order may be changed without notice. Purchaser's approval of this data set signifies that the equipment is acceptable under the provisions of the job specification. Statements and other information contained herein are not express warranties and do not form the basis of any bargain between the parties, but are merely the manufacturer's opinion or commendation of its products.

Contractor: \_\_\_\_\_ P.O.: \_\_\_\_\_

Engineer: \_\_\_\_\_

Project Name: \_\_\_\_\_ Unit Tag: \_\_\_\_\_

**Arbor Base Series Commercial  
Geothermal/Water Source Heat Pumps  
0.5-6 Tons, 60Hz**



## ZB042 - Performance Data

### Single Speed with Variable Speed ECM or 5-Speed ECM (1400 CFM)

EWT °F	Flow GPM	WPD		HEATING - EAT 70°F					COOLING - EAT 80/67°F					
		psi	ft	HC MBtu/h	Power kW	HE MBtu/h	LAT °F	COP	TC MBtu/h	SC MBtu/h	S/T Ratio	Power kW	HR MBtu/h	EER
20	5.0	2.2	5.1	Operation not recommended					Operation not recommended					
	8.0	4.9	11.3	Operation not recommended					Operation not recommended					
	11.0	7.6	17.6	25.4	2.11	18.2	84.8	3.53	Operation not recommended					
30	5.0	2.1	4.9	Operation not recommended					Operation not recommended					
	8.0	4.8	11.1	31.3	2.33	23.4	88.7	3.94	48.8	33.4	0.68	1.55	54.1	31.4
	11.0	7.5	17.2	30.4	2.28	22.6	88.1	3.91	49.5	34.1	0.69	1.46	54.5	33.9
40	5.0	2.1	4.9	Operation not recommended					Operation not recommended					
	8.0	4.8	11.1	35.1	2.45	26.7	91.2	4.20	49.5	34.0	0.69	1.77	55.6	27.9
	11.0	7.5	17.3	35.8	2.45	27.4	91.7	4.28	50.4	34.5	0.68	1.65	56.0	30.5
50	5.0	2.0	4.6	37.3	2.52	28.7	92.7	4.34	49.2	34.0	0.69	2.14	56.5	23.0
	8.0	4.7	10.9	39.2	2.57	30.4	93.9	4.47	50.2	34.5	0.69	1.99	57.0	25.2
	11.0	7.4	17.0	41.1	2.62	32.2	95.2	4.60	51.3	35.0	0.68	1.84	57.6	27.9
60	5.0	1.9	4.4	42.3	2.65	33.3	96.0	4.68	46.3	33.1	0.71	2.37	54.4	19.6
	8.0	4.6	10.5	44.2	2.70	35.0	97.2	4.79	47.4	33.5	0.71	2.22	55.0	21.3
	11.0	7.2	16.6	46.1	2.76	36.7	98.5	4.90	48.4	33.8	0.70	2.08	55.5	23.3
70	5.0	1.8	4.2	47.3	2.78	37.8	99.3	4.99	43.5	32.2	0.74	2.59	52.3	16.8
	8.0	4.5	10.4	49.2	2.84	39.5	100.5	5.08	44.5	32.4	0.73	2.46	52.9	18.1
	11.0	7.0	16.2	51.1	2.89	41.2	101.8	5.18	45.5	32.6	0.72	2.32	53.5	19.6
80	5.0	1.7	3.9	52.8	2.89	42.9	102.9	5.35	40.9	31.1	0.76	2.78	50.3	14.7
	8.0	4.5	10.4	54.1	2.94	44.1	103.8	5.40	41.7	31.3	0.75	2.65	50.7	15.7
	11.0	6.8	15.7	55.5	2.99	45.4	104.7	5.45	42.6	31.6	0.74	2.57	51.3	16.6
90	5.0	1.6	3.7	58.2	3.00	48.0	106.5	5.68	38.2	30.1	0.79	3.04	48.6	12.6
	8.0	4.4	10.2	59.1	3.04	48.7	107.1	5.69	38.8	30.3	0.78	2.90	48.7	13.4
	11.0	6.6	15.3	60.0	3.08	49.5	107.7	5.71	39.6	30.6	0.77	2.81	49.2	14.1
100	5.0	1.5	3.5	Operation not recommended					Operation not recommended					
	8.0	4.3	9.9	Operation not recommended					36.0	29.2	0.81	3.15	46.8	11.4
	11.0	6.2	14.3	Operation not recommended					36.6	29.4	0.80	3.05	47.0	12.0
110	5.0	1.4	3.2	Operation not recommended					Operation not recommended					
	8.0	4.2	9.7	Operation not recommended					32.9	27.8	0.84	3.38	44.4	9.7
	11.0	6.1	14.2	Operation not recommended					33.6	28.2	0.84	3.29	44.8	10.2
120	5.0	1.4	3.2	Operation not recommended					Operation not recommended					
	8.0	4.2	9.7	Operation not recommended					30.2	25.8	0.86	3.61	42.5	8.4
	11.0	6.1	14.1	Operation not recommended					30.8	26.2	0.85	3.50	42.7	8.8

5/1/11

The manufacturer works continually to improve its products. As a result, the design and specifications of each product at the time of order may be changed without notice. Purchaser's approval of this data set signifies that the equipment is acceptable under the provisions of the job specification. Statements and other information contained herein are not express warranties and do not form the basis of any bargain between the parties, but are merely the manufacturer's opinion or commendation of its products.



Contractor: \_\_\_\_\_ P.O.: \_\_\_\_\_

Engineer: \_\_\_\_\_

Project Name: \_\_\_\_\_ Unit Tag: \_\_\_\_\_



## ZB048 - Performance Data

### Single Speed with Variable Speed ECM or 5-Speed ECM (1600 CFM)

EWT °F	Flow GPM	WPD		HEATING - EAT 70°F					COOLING - EAT 80/67°F					
		psi	ft	HC MBtu/h	Power kW	HE MBtu/h	LAT °F	COP	TC MBtu/h	SC MBtu/h	S/T Ratio	Power kW	HR MBtu/h	EER
20	6.0	2.8	6.5	Operation not recommended					Operation not recommended					
	9.0	6.1	14.1	Operation not recommended					Operation not recommended					
	12.0	10.4	24.1	31.2	2.74	21.9	86.1	3.34	Operation not recommended					
30	6.0	2.7	6.2	Operation not recommended					Operation not recommended					
	9.0	6.0	13.9	36.6	2.88	26.8	89.2	3.72	56.2	38.3	0.68	2.16	63.5	26.1
	12.0	9.5	22.0	36.3	2.93	26.3	89.0	3.63	56.9	39.1	0.69	2.02	63.8	28.1
40	6.0	2.7	6.2	Operation not recommended					Operation not recommended					
	9.0	6.0	13.9	41.5	3.07	31.0	92.0	3.96	58.1	39.5	0.68	2.41	66.3	24.1
	12.0	9.4	21.7	42.6	3.13	31.9	92.7	3.98	58.9	40.0	0.68	2.27	66.6	26.0
50	6.0	2.6	6.0	45.0	3.20	34.1	94.1	4.12	59.2	40.4	0.68	2.82	68.8	21.0
	9.0	5.9	13.6	47.0	3.27	35.8	95.2	4.21	60.0	40.7	0.68	2.66	69.1	22.5
	12.0	9.3	21.4	48.9	3.34	37.5	96.3	4.29	60.9	41.0	0.67	2.51	69.4	24.3
60	6.0	2.5	5.8	51.3	3.42	39.7	97.7	4.40	56.1	38.9	0.69	3.09	66.6	18.2
	9.0	5.8	13.4	53.7	3.49	41.8	99.1	4.51	57.1	39.2	0.69	2.94	67.1	19.4
	12.0	9.2	21.3	56.0	3.57	43.9	100.4	4.60	58.0	39.5	0.68	2.79	67.5	20.8
70	6.0	2.4	5.5	57.6	3.63	45.2	101.4	4.65	53.0	37.4	0.70	3.35	64.5	15.8
	9.0	5.4	12.5	60.4	3.71	47.7	103.0	4.77	54.1	37.7	0.70	3.21	65.1	16.9
	12.0	8.5	19.6	63.2	3.80	50.2	104.6	4.88	55.2	38.0	0.69	3.06	65.7	18.0
80	6.0	2.3	5.3	65.0	3.85	51.8	105.6	4.95	49.4	36.1	0.73	3.62	61.8	13.6
	9.0	5.3	12.2	66.9	3.92	53.5	106.7	5.01	50.3	36.3	0.72	3.46	62.1	14.6
	12.0	8.4	19.4	68.8	3.98	55.3	107.8	5.07	51.3	36.6	0.71	3.34	62.7	15.3
90	6.0	2.2	5.1	72.3	4.06	58.4	109.8	5.21	45.8	34.8	0.76	3.93	59.2	11.7
	9.0	5.2	12.0	73.4	4.12	59.3	110.5	5.22	46.5	35.0	0.75	3.74	59.3	12.4
	12.0	8.3	19.2	74.5	4.17	60.3	111.1	5.24	47.4	35.2	0.74	3.62	59.8	13.1
100	6.0	2.1	4.9	Operation not recommended					Operation not recommended					
	9.0	5.2	12.0	Operation not recommended					42.8	33.1	0.77	4.01	56.5	10.7
	12.0	8.2	18.9	Operation not recommended					43.4	33.4	0.77	3.88	56.7	11.2
110	6.0	2.0	4.6	Operation not recommended					Operation not recommended					
	9.0	5.1	11.8	Operation not recommended					38.6	31.1	0.81	4.25	53.1	9.1
	12.0	8.1	18.8	Operation not recommended					39.4	31.6	0.80	4.14	53.5	9.5
120	6.0	1.9	4.4	Operation not recommended					Operation not recommended					
	9.0	5.0	11.6	Operation not recommended					34.7	29.4	0.85	4.51	50.1	7.7
	12.0	8.0	18.5	Operation not recommended					35.4	29.9	0.84	4.38	50.4	8.1

5/1/11

The manufacturer works continually to improve its products. As a result, the design and specifications of each product at the time of order may be changed without notice. Purchaser's approval of this data set signifies that the equipment is acceptable under the provisions of the job specification. Statements and other information contained herein are not express warranties and do not form the basis of any bargain between the parties, but are merely the manufacturer's opinion or commendation of its products.

Contractor: \_\_\_\_\_ P.O.: \_\_\_\_\_

Engineer: \_\_\_\_\_

Project Name: \_\_\_\_\_ Unit Tag: \_\_\_\_\_

**Arbor Base Series Commercial  
Geothermal/Water Source Heat Pumps  
0.5-6 Tons, 60Hz**



## ZB060 - Performance Data

### Single Speed with Variable Speed ECM or 5-Speed ECM (2000 CFM)

EWT °F	Flow GPM	WPD		HEATING - EAT 70°F					COOLING - EAT 80/67°F					
		psi	ft	HC MBtu/h	Power kW	HE MBtu/h	LAT °F	COP	TC MBtu/h	SC MBtu/h	S/T Ratio	Power kW	HR MBtu/h	EER
20	9.0	4.6	10.6	Operation not recommended					Operation not recommended					
	12.0	7.3	16.9											
	15.0	10.0	23.1	35.5	3.36	24.0	85.3	3.09						
30	9.0	4.5	10.4	Operation not recommended					Operation not recommended					
	12.0	6.5	15.0	41.2	3.51	29.3	88.1	3.44	64.9	42.4	0.65	2.52	73.5	25.7
	15.0	8.6	19.8	41.2	3.56	29.1	88.1	3.40	65.8	43.3	0.66	2.37	73.9	27.8
40	9.0	4.5	10.4	Operation not recommended					Operation not recommended					
	12.0	6.5	15.0	46.4	3.76	33.6	90.6	3.62	66.2	44.3	0.67	2.79	75.7	23.7
	15.0	8.6	19.9	47.5	3.83	34.4	91.1	3.64	67.0	44.7	0.67	2.66	76.0	25.2
50	9.0	4.4	10.0	50.6	3.96	37.1	92.7	3.75	66.8	46.2	0.69	3.18	77.7	21.0
	12.0	6.3	14.4	52.2	4.03	38.4	93.4	3.80	67.5	46.1	0.68	3.07	77.9	22.0
	15.0	8.1	18.8	53.7	4.09	39.7	94.2	3.85	68.1	46.1	0.68	2.95	78.2	23.1
60	9.0	4.3	9.9	56.8	4.23	42.4	95.7	3.94	63.5	45.0	0.71	3.51	75.5	18.1
	12.0	6.2	14.3	59.2	4.32	44.4	96.8	4.01	64.2	45.0	0.70	3.40	75.8	18.9
	15.0	8.0	18.5	61.5	4.42	46.4	98.0	4.08	64.9	45.1	0.70	3.29	76.1	19.7
70	9.0	4.2	9.6	63.0	4.49	47.6	98.7	4.11	60.3	43.7	0.73	3.83	73.3	15.7
	12.0	6.1	14.1	66.1	4.62	50.4	100.2	4.20	60.9	43.9	0.72	3.73	73.7	16.3
	15.0	7.9	18.2	69.3	4.74	53.1	101.8	4.29	61.6	44.1	0.72	3.63	74.0	17.0
80	9.0	4.1	9.5	70.6	4.77	54.4	102.4	4.34	56.2	41.8	0.74	4.31	70.9	13.1
	12.0	6.0	13.9	72.8	4.86	56.2	103.5	4.39	57.0	42.1	0.74	4.11	71.0	13.9
	15.0	7.8	18.0	75.0	4.96	58.1	104.6	4.44	57.9	42.3	0.73	3.98	71.4	14.6
90	9.0	4.0	9.2	78.3	5.04	61.1	106.2	4.55	52.2	39.9	0.76	4.68	68.1	11.1
	12.0	5.9	13.6	79.5	5.11	62.1	106.7	4.56	53.0	40.2	0.76	4.46	68.2	11.9
	15.0	7.7	17.8	80.7	5.17	63.1	107.3	4.58	54.1	40.5	0.75	4.32	68.8	12.5
100	9.0	3.9	9.0	Operation not recommended					Operation not recommended					
	12.0	5.8	13.4						48.8	38.5	0.79	4.84	65.3	10.1
	15.0	7.6	17.6						49.5	38.8	0.78	4.68	65.5	10.6
110	9.0	3.8	8.8	Operation not recommended					Operation not recommended					
	12.0	5.7	13.2						44.1	36.5	0.83	5.18	61.8	8.5
	15.0	7.5	17.3						45.0	37.1	0.82	5.04	62.2	8.9
120	9.0	3.7	8.5	Operation not recommended					Operation not recommended					
	12.0	5.6	12.9						39.7	34.6	0.87	5.55	58.7	7.2
	15.0	7.4	17.1						40.6	35.1	0.86	5.39	59.0	7.5

5/1/11

The manufacturer works continually to improve its products. As a result, the design and specifications of each product at the time of order may be changed without notice. Purchaser's approval of this data set signifies that the equipment is acceptable under the provisions of the job specification. Statements and other information contained herein are not express warranties and do not form the basis of any bargain between the parties, but are merely the manufacturer's opinion or commendation of its products.

Contractor: \_\_\_\_\_ P.O.: \_\_\_\_\_

Engineer: \_\_\_\_\_

Project Name: \_\_\_\_\_ Unit Tag: \_\_\_\_\_

**Arbor Base Series Commercial  
Geothermal/Water Source Heat Pumps  
0.5-6 Tons, 60Hz**



## ZB070 - Performance Data

### Single Speed with Variable Speed ECM or 5-Speed ECM (2200 CFM)

EWT °F	Flow GPM	WPD		HEATING - EAT 70°F					COOLING - EAT 80/67°F					
		psi	ft	HC MBtu/h	Power kW	HE MBtu/h	LAT °F	COP	TC MBtu/h	SC MBtu/h	S/T Ratio	Power kW	HR MBtu/h	EER
20	12.0	5.8	13.4	Operation not recommended					Operation not recommended					
	15.0	9.1	20.9											
	18.0	12.3	28.4	42.5	3.77	29.6	86.7	3.30						
30	12.0	5.7	13.2	Operation not recommended					Operation not recommended					
	15.0	8.9	20.4	50.2	4.36	35.3	90.1	3.37	66.2	41.5	0.63	2.79	75.8	23.7
	18.0	12.0	27.7	48.6	3.99	35.0	89.4	3.57	67.1	42.4	0.63	2.62	76.1	25.6
40	12.0	5.7	13.2	Operation not recommended					Operation not recommended					
	15.0	8.9	20.4	56.9	4.40	41.9	93.1	3.79	71.3	46.6	0.65	3.05	81.7	23.4
	18.0	12.0	27.7	57.0	4.24	42.6	93.1	3.95	71.4	46.5	0.65	2.92	81.4	24.5
50	12.0	5.6	13.0	63.3	4.42	48.2	95.9	4.20	76.8	52.6	0.68	3.40	88.4	22.6
	15.0	8.6	19.8	64.3	4.45	49.2	96.4	4.24	76.3	51.6	0.68	3.31	87.6	23.0
	18.0	11.5	26.6	65.4	4.48	50.1	96.8	4.28	75.7	50.6	0.67	3.22	86.7	23.5
60	12.0	5.5	12.7	72.1	4.26	57.6	99.8	4.96	74.2	52.2	0.70	3.78	87.1	19.6
	15.0	8.4	19.3	73.6	4.50	58.2	100.4	4.79	74.2	51.7	0.70	3.69	86.7	20.1
	18.0	11.2	25.9	75.0	4.74	58.8	101.1	4.64	74.2	51.3	0.69	3.60	86.4	20.6
70	12.0	5.4	12.5	80.9	4.10	66.9	103.7	5.79	71.5	51.8	0.72	4.15	85.7	17.2
	15.0	8.2	18.9	82.8	4.55	67.3	104.5	5.34	72.1	51.9	0.72	4.06	85.9	17.7
	18.0	11.0	25.5	84.6	4.99	67.6	105.3	4.97	72.6	51.9	0.72	3.97	86.1	18.3
80	12.0	5.3	12.2	88.9	4.69	72.9	107.2	5.56	66.5	50.3	0.76	4.74	82.6	14.0
	15.0	7.9	18.2	90.6	4.94	73.7	107.9	5.37	67.2	50.4	0.75	4.52	82.6	14.9
	18.0	10.5	24.3	92.2	5.20	74.5	108.7	5.20	68.1	50.5	0.74	4.38	83.0	15.6
90	12.0	5.2	12.0	96.9	5.27	78.9	110.7	5.38	61.4	48.7	0.79	5.18	79.1	11.9
	15.0	7.7	17.7	98.4	5.34	80.1	111.4	5.39	62.3	48.9	0.78	4.94	79.2	12.6
	18.0	10.1	23.4	99.9	5.41	81.4	112.0	5.41	63.6	49.1	0.77	4.78	79.9	13.3
100	12.0	5.1	11.8	Operation not recommended					Operation not recommended					
	15.0	7.3	16.7						57.6	46.3	0.80	5.33	75.8	10.8
	18.0	9.4	21.7						58.5	46.7	0.80	5.16	76.1	11.3
110	12.0	5.0	11.6	Operation not recommended					Operation not recommended					
	15.0	6.7	15.5						52.3	43.7	0.84	5.70	71.7	9.2
	18.0	8.4	19.5						53.3	44.4	0.83	5.54	72.2	9.6
120	12.0	4.9	11.3	Operation not recommended					Operation not recommended					
	15.0	6.6	15.2						47.5	41.8	0.88	6.10	68.3	7.8
	18.0	8.3	19.1						48.5	42.4	0.87	5.92	68.7	8.2

5/1/11

The manufacturer works continually to improve its products. As a result, the design and specifications of each product at the time of order may be changed without notice. Purchaser's approval of this data set signifies that the equipment is acceptable under the provisions of the job specification. Statements and other information contained herein are not express warranties and do not form the basis of any bargain between the parties, but are merely the manufacturer's opinion or commendation of its products.



Contractor: \_\_\_\_\_ P.O.: \_\_\_\_\_

Engineer: \_\_\_\_\_

Project Name: \_\_\_\_\_ Unit Tag: \_\_\_\_\_

**Arbor Base Series Commercial  
Geothermal/Water Source Heat Pumps  
0.5-6 Tons, 60Hz**



**Wiring Schematics cont.**

**Aurora Base Control 208-230/60/1 PSC**

**Notes:**

- 1 - Optional, factory installed unit mounted disconnect.
- 2 - Swap blue and red leads for 208V operation.
- 3 - Optional, factory installed internal isolation valve.

**Legend**

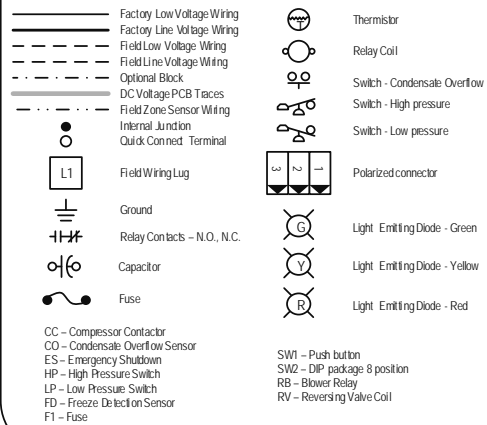

Aurora LED Flash Codes				
Slow Flash	1 second on and 1 second off			
Fast Flash	100 milliseconds on and 100 milliseconds off			
Flash Code	100 milliseconds on and 400 milliseconds off with a 2 second pause before repeating			
Random Start Delay				
Status LED (LED1, Green)	Fast Flash			
Configuration LED (LED2, Yellow)	Fast Flash			
Fault LED (LED3, Red)	Fast Flash			
Status LED (LED1, Green)	Configuration LED (LED2, Yellow)	Fault LED (LED3, Red)		
Normal Mode	ON	No Software Override	Flash EOM Setting	Normal Mode
Control Is Non-Functional	OFF	DIP Switch Override	Slow Flash	Input Fault Lockout
Test Mode	Slow Flash	ECM Configure Mode	Fast Flash	High Pressure Lockout
Lockout Active	Fast Flash	Reset Configure Mode	Off	Low Pressure Lockout
Dehumidification Mode	Flash Code 2			Low Air Coil Limit Lockout - FP2
Reserved	Flash Code 3			Low Water Coil Limit Lockout - FP1
Reserved	Flash Code 4			Reserved
Load Shed	Flash Code 5			Condensate Overflow Lockout
ESD	Flash Code 6			Over/Under Voltage Shutdown
Reserved	Flash Code 7			Reserved
				Reserved
				Air/Water Coil Limit Sensor Error
				Flash Code 11

Aurora Timing Events		
Event	Normal Mode	Test Mode
Random Start Delay	5 to 80 seconds	1 second
Compressor On Delay	5 seconds	< 1 second
Compressor Minimum On Time	2 minutes	5 seconds
Compressor Short Cycle Delay	4 minutes	15 seconds
Blower Off Delay	30 seconds	2 seconds
Fault Recognition Delay - High Pressure	Less than 1 second	Less than 1 second
Start-Up Bypass - Low Pressure	2 minutes	30 seconds
Fault Recognition Delay - Low Pressure	30 seconds	30 seconds
Start-Up Bypass - Low Water/Air Coil Limit	2 minutes	30 seconds
Fault Recognition Delay - Low Water/Air Coil Limit	30 seconds	30 seconds
Fault Recognition Delay - Condensate Overflow	30 seconds	30 seconds
Thermostat Call Recognition Time	2 seconds	2 seconds
Auxiliary Heat Staging Delay	5 minutes	20 seconds
Emergency Heat Staging Delay	2 minutes	7.5 seconds
Water Valve Slow Open Delay	90 seconds	90 seconds
Reheat Delay	30 seconds	30 seconds

Accessory Relay		
Operation	SW2-4	SW2-5
Cycle with Blower	On	On
Cycle with Compressor	Off	Off
Water Valve Slow Open	On	Off
Outdoor Air Damper	Off	On

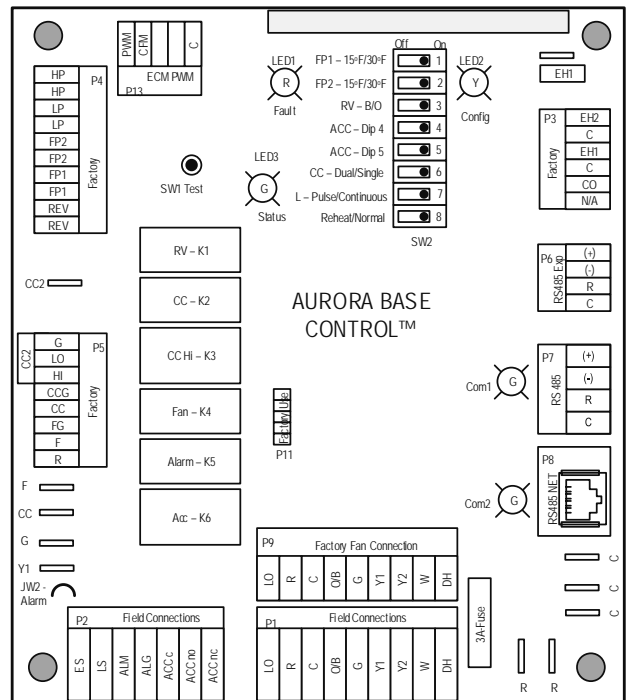

The manufacturer works continually to improve its products. As a result, the design and specifications of each product at the time of order may be changed without notice. Purchaser's approval of this data set signifies that the equipment is acceptable under the provisions of the job specification. Statements and other information contained herein are not express warranties and do not form the basis of any bargain between the parties, but are merely the manufacturer's opinion or commendation of its products.

Contractor: \_\_\_\_\_ P.O.: \_\_\_\_\_

Engineer: \_\_\_\_\_

Project Name: \_\_\_\_\_ Unit Tag: \_\_\_\_\_

**Arbor Base Series Commercial  
Geothermal/Water Source Heat Pumps  
0.5-6 Tons, 60Hz**



# Wiring Schematics cont.

## Aurora Base Control 460/60/3 5-Speed ECM

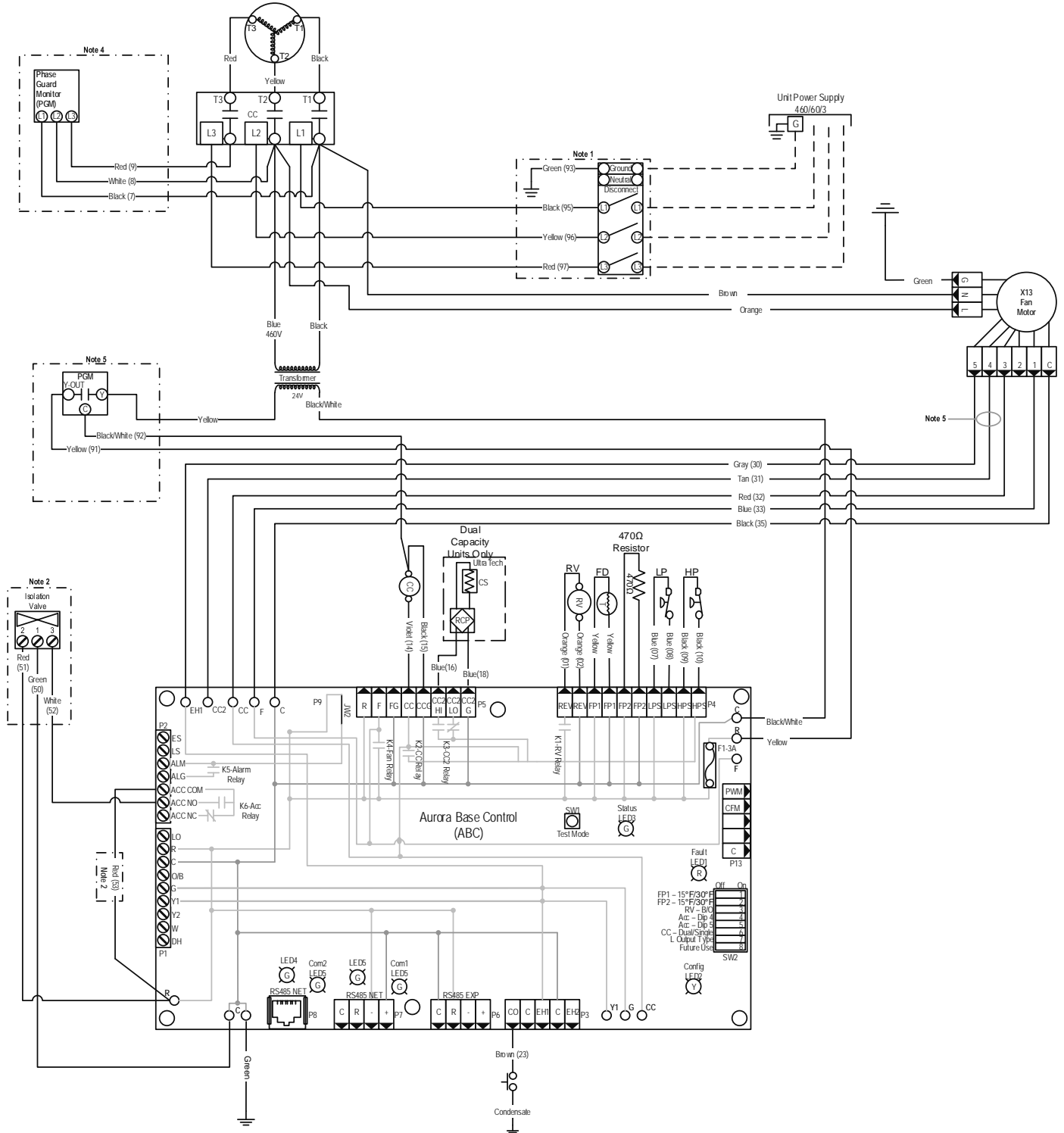

The manufacturer works continually to improve its products. As a result, the design and specifications of each product at the time of order may be changed without notice. Purchaser's approval of this data set signifies that the equipment is acceptable under the provisions of the job specification. Statements and other information contained herein are not express warranties and do not form the basis of any bargain between the parties, but are merely the manufacturer's opinion or commendation of its products.

Contractor: \_\_\_\_\_ P.O.: \_\_\_\_\_

Engineer: \_\_\_\_\_

Project Name: \_\_\_\_\_ Unit Tag: \_\_\_\_\_

**Arbor Base Series Commercial  
Geothermal/Water Source Heat Pumps  
0.5-6 Tons, 60Hz**



**Wiring Schematics cont.**

**Aurora Base Control 460/60/3 5-Speed ECM**

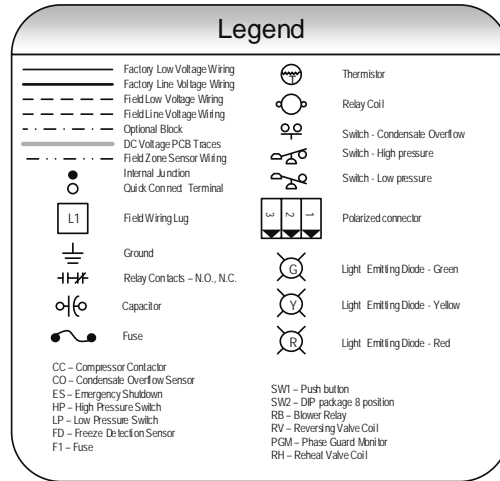

Aurora LED Flash Codes			
Slow Flash	1 second on and 1 second off		
Fast Flash	100 milliseconds on and 100 milliseconds off		
Flash Code	100 milliseconds on and 400 milliseconds off with a 2 second pause before repeating		
Random Start Delay			
Status LED (LED1, Green)	Fast Flash		
Configuration LED (LED2, Yellow)	Fast Flash		
Fault LED (LED3, Red)	Fast Flash		
Status LED (LED1, Green)	Configuration LED (LED2, Yellow)	Fault LED (LED3, Red)	
Normal Mode	ON	No Software Override	Flash ECM Setting
Control is Non-Functional	OFF	DIP Switch Override	Slow Flash
Test Mode	Slow Flash	ECM Configure Mode	Fast Flash
Lockout Active	Fast Flash	Reset Configure Mode	OFF
Dehumidification Mode	Flash Code 2	Low Air Coil Limit Lockout - FP2	Flash Code 4
Reserved	Flash Code 3	Low Water Coil Limit Lockout - FP1	Flash Code 5
Reserved	Flash Code 4	Reserved	Flash Code 6
Load Shed	Flash Code 5	Condensate Overflow Lockout	Flash Code 7
ESD	Flash Code 6	Over/Under Voltage Shutdown	Flash Code 8
Reserved	Flash Code 7	Reserved	Flash Code 9
		Reserved	Flash Code 10
		Air/Water Coil Limit Sensor Error	Flash Code 11

**Notes:**

- 1 - Optional, factory installed unit mounted disconnect.
- 2 - Optional, factory installed internal isolation valve.
- 3 - Optional, factory installed phase guard.
- 4 - Optional, factory installed phase guard. The yellow transformer wire shall be connected directly to the CPU board, if this option is not installed.
- 5 - Wires provided with the unit but only connected to the X13 motor for dual capacity units.

Accessory Relay		
Operation	SW2-4	SW2-5
Cycle with Blower	On	On
Cycle with Compressor	Off	Off
Water Valve Slow Open	On	Off
Outdoor Air Damper	Off	On

Aurora Timing Events		
Event	Normal Mode	Test Mode
Random Start Delay	5 to 80 seconds	1 second
Compressor On Delay	5 seconds	< 1 second
Compressor Minimum On Time	2 minutes	5 seconds
Compressor Short Cycle Delay	4 minutes	15 seconds
Blower Off Delay	30 seconds	2 seconds
Fault Recognition Delay - High Pressure	Less than 1 second	Less than 1 second
Start Up Bypass - Low Pressure	2 minutes	30 seconds
Fault Recognition Delay - Low Pressure	30 seconds	30 seconds
Start Up Bypass - Low Water/Air Coil Limit	2 minutes	30 seconds
Fault Recognition Delay - Low Water/Air Coil Limit	30 seconds	30 seconds
Fault Recognition Delay - Condensate Overflow	30 seconds	30 seconds
Thermostat Call Recognition Time	2 seconds	2 seconds
Auxiliary Heat Staging Delay	5 minutes	20 seconds
Emergency Heat Staging Delay	2 minutes	7.5 seconds
Water Valve Slow Open Delay	90 seconds	90 seconds
Reheat Delay	30 seconds	30 seconds

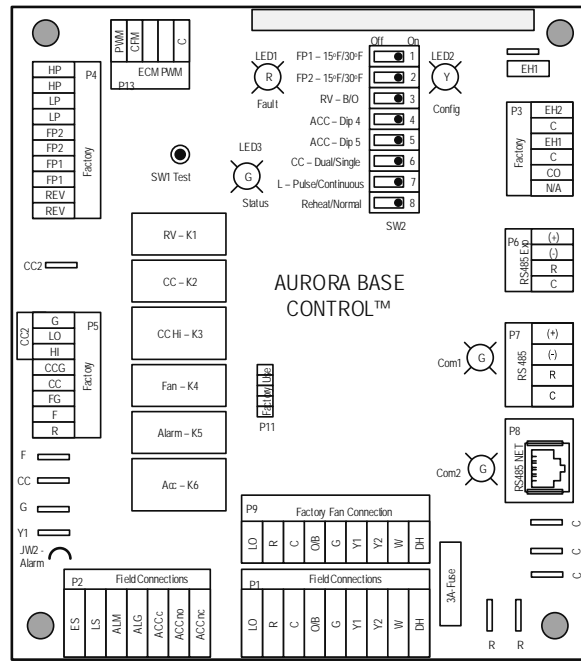

The manufacturer works continually to improve its products. As a result, the design and specifications of each product at the time of order may be changed without notice. Purchaser's approval of this data set signifies that the equipment is acceptable under the provisions of the job specification. Statements and other information contained herein are not express warranties and do not form the basis of any bargain between the parties, but are merely the manufacturer's opinion or commendation of its products.

Contractor: \_\_\_\_\_ P.O.: \_\_\_\_\_

Engineer: \_\_\_\_\_

Project Name: \_\_\_\_\_ Unit Tag: \_\_\_\_\_

**Arbor Base Series Commercial  
Geothermal/Water Source Heat Pumps  
0.5-6 Tons, 60Hz**



# Wiring Schematics cont.

## Aurora Base Control 460/60/3 Variable Speed ECM

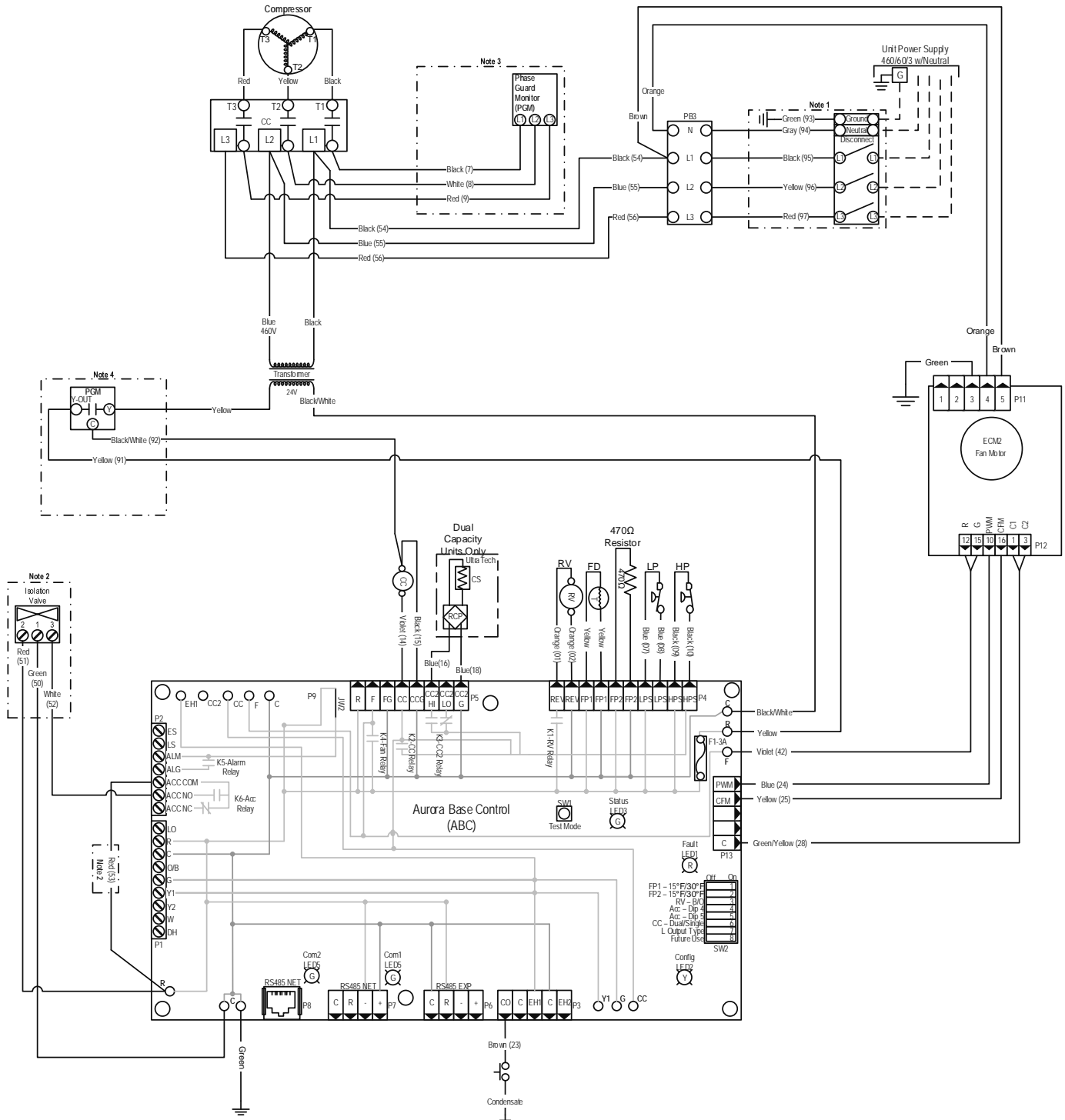

The manufacturer works continually to improve its products. As a result, the design and specifications of each product at the time of order may be changed without notice. Purchaser's approval of this data set signifies that the equipment is acceptable under the provisions of the job specification. Statements and other information contained herein are not express warranties and do not form the basis of any bargain between the parties, but are merely the manufacturer's opinion or commendation of its products.



Contractor: \_\_\_\_\_ P.O.: \_\_\_\_\_  
 Engineer: \_\_\_\_\_  
 Project Name: \_\_\_\_\_ Unit Tag: \_\_\_\_\_

**Arbor Base Series Commercial  
 Geothermal/Water Source Heat Pumps  
 0.5-6 Tons, 60Hz**



**Wiring Schematics cont.**

**Aurora Base Control 460/60/3 Variable Speed ECM**

**Notes:**

- 1 - Optional, factory installed unit mounted disconnect.
- 2 - Optional, factory installed internal isolation valve.
- 3 - Optional, factory installed phase guard.
- 4 - Optional, factory installed phase guard. The yellow transformer wire shall be connected directly to the CPU board, if this option is not installed.

**Legend**

Factory Low Voltage Wiring  
 Factory Line Voltage Wiring  
 Field Low Voltage Wiring  
 Field Line Voltage Wiring  
 Optional Block  
 DC Voltage/PCB Traces  
 Field Zone Sensor Wiring  
 Internal Junction  
 Quick Connect Terminal  
 Field Wiring Lug  
 Ground  
 Relay Contacts - N.O., N.C.  
 Capacitor  
 Fuse  
 Thermistor  
 Relay Coil  
 Switch - Condensate Overflow  
 Switch - High pressure  
 Switch - Low pressure  
 Polarized connector  
 Light Emitting Diode - Green  
 Light Emitting Diode - Yellow  
 Light Emitting Diode - Red  
 CC - Compressor Contactor  
 CO - Condensate Overflow Sensor  
 ES - Emergency Shutdown  
 HP - High Pressure Switch  
 LP - Low Pressure Switch  
 FD - Freeze Detection Sensor  
 F1 - Fuse  
 SW1 - Push button  
 SW2 - DP package 8 position  
 RB - Blower Relay  
 RV - Reversing Valve Coil  
 PGM - Phase Guard Monitor  
 RH - Reheat Valve Coil

Aurora LED Flash Codes			
Slow Flash	1 second on and 1 second off		
Fast Flash	100 milliseconds on and 100 milliseconds off		
Flash Code	100 milliseconds on and 400 milliseconds off with a 2 second pause before repeating		
Random Start Delay			
Status LED (LED1, Green)	Fast Flash		
Configuration LED (LED2, Yellow)	Fast Flash		
Fault LED (LED3, Red)	Fast Flash		
Status LED (LED1, Green)	Configuration LED (LED2, Yellow)	Fault LED (LED3, Red)	
Normal Mode	ON	No Software Override	Flash ECM Setting
Control is Non-Functional	OFF	DIP Switch Override	Slow Flash
Test Mode	Slow Flash	ECM Configure Mode	Fast Flash
Lockout Active	Fast Flash	Reset Configure Mode	OFF
Dehumidification Mode	Flash Code 2		Low Air Coil Limit Lockout - FP2
Reserved	Flash Code 3		Low Water Coil Limit Lockout - FP1
Reserved	Flash Code 4		Reserved
Load Shed	Flash Code 5		Condensate Overflow Lockout
ESD	Flash Code 6		Over/Under Voltage Shutdown
Reserved	Flash Code 7		Reserved
			Reserved
			Flash Code 10
			Air/Water Coil Limit Sensor Error
			Flash Code 11

Accessory Relay		
Operation	SW2-1	SW2-2
Cycle with Blower	On	On
Cycle with Compressor	Off	Off
Water Valve Slow Open	On	Off
Outdoor Air Damper	Off	On

Aurora Timing Events		
Event	Normal Mode	Test Mode
Random Start Delay	5 to 80 seconds	1 second
Compressor On Delay	5 seconds	< 1 second
Compressor Minimum On Time	2 minutes	5 seconds
Compressor Short Cycle Delay	4 minutes	15 seconds
Blower Off Delay	30 seconds	2 seconds
Fault Recognition Delay - High Pressure	Less than 1 second	Less than 1 second
Start-Up Bypass - Low Pressure	2 minutes	30 seconds
Fault Recognition Delay - Low Pressure	30 seconds	30 seconds
Start-Up Bypass - Low Water/Air Coil Limit	2 minutes	30 seconds
Fault Recognition Delay - Low Water/Air Coil Limit	30 seconds	30 seconds
Fault Recognition Delay - Condensate Overflow	30 seconds	30 seconds
Thermostat Call Recognition Time	2 seconds	2 seconds
Auxiliary Heat Staging Delay	5 minutes	20 seconds
Emergency Heat Staging Delay	2 minutes	7.5 seconds
Water Valve Slow Open Delay	90 seconds	90 seconds
Reheat Delay	30 seconds	30 seconds

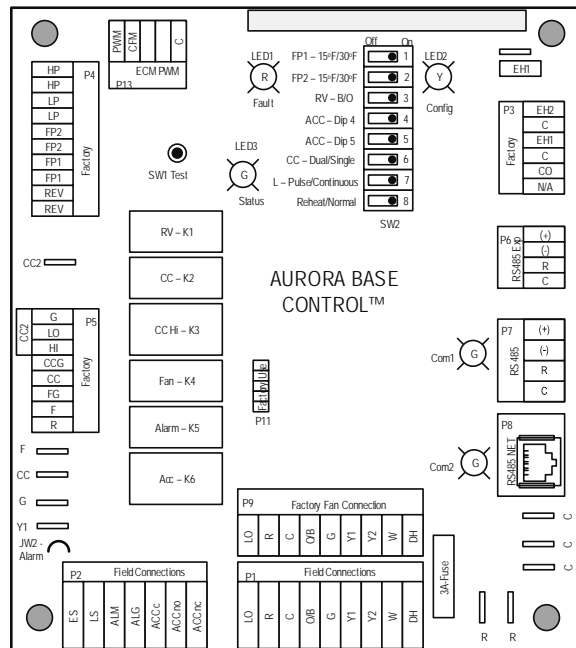

The manufacturer works continually to improve its products. As a result, the design and specifications of each product at the time of order may be changed without notice. Purchaser's approval of this data set signifies that the equipment is acceptable under the terms of the job specification. Statements and other information contained herein are not express warranties and do not form the basis of any bargain between the parties, but are merely the manufacturer's opinion or commendation of its products.

Contractor: \_\_\_\_\_ P.O.: \_\_\_\_\_

Engineer: \_\_\_\_\_

Project Name: \_\_\_\_\_ Unit Tag: \_\_\_\_\_



## Engineering Guide Specifications

### General

Furnish and install Water Source Heat Pumps as indicated on the plans. Equipment shall be completely assembled, piped and internally wired. Capacities and characteristics as listed in the schedule and the specifications that follow. The reverse cycle heating/cooling units shall be either suspended type with horizontal air inlet and discharge or floor mounted type with horizontal air inlet and vertical upflow air discharge. Units shall be AHRI/ISO 13256-1 certified and listed by a nationally recognized safety-testing laboratory or agency, such as ETL Testing Laboratory. Each unit shall be computer run-tested at the factory with conditioned water and operation verified to catalog data. Each unit shall be mounted on a pallet and shipped in a corrugated box or stretch-wrapped. The units shall be designed to operate with entering liquid temperature between 20°F and 120°F [-6.7°C and 48.9°C].

### Casing and Cabinet

The cabinet shall be fabricated from heavy-gauge galvanized steel. The interior shall be insulated with 1/2 in. thick, multi-density, cleanable aluminum foil coated glass fiber with edges sealed or tucked under flanges to prevent the introduction of glass fibers into the discharge air. Standard cabinet panel insulation must meet NFPA 90A requirements, air erosion and mold growth limits of UL-181, stringent fungal resistance test per ASTM-C1071 and ASTM G21, and shall meet zero level bacteria growth per ASTM G22. Unit insulation must meet these stringent requirements or unit(s) will not be accepted.

One (horizontal) to two (vertical) blower and two compressor compartment access panels shall be 'lift-out' removable with supply and return ductwork in place.

A duct collar shall be provided on the supply air opening. Standard size 1 in. [2.54 cm] MERV 4 filters shall be provided with each unit. Units shall have a return air filter rack that is field convertible from 1 in. [2.54 cm] to 2 in. [5.1 cm]. The upflow vertical units shall have a removable insulated divider panel between the air handling section and the compressor section to minimize the transmission of compressor noise and to permit operational service testing without air bypass. Vertical units shall be supplied with left or right horizontal air inlet and top vertical air discharge. Horizontal units shall be supplied with left or right air inlet and side or end air discharge.

**Option: AlpinePure MERV 13 Filter** - A 2 in. thick [51 mm] MERV 13 filter can help fulfill a credit under the LEED Rating System. Its low initial resistance promotes low energy consumption (0.21 in. w.g. @ 300 fpm) and provides nearly twice the life of a standard filter (300 fpm vs. standard 500 fpm application).

Option: A Super Quiet Sound package shall include multi-density full coverage compressor blanket.

**Option: An internally mounted low pressure drop (high Cv) water solenoid valve** shall be factory installed for use in variable speed pumping applications.

**Option: An internally mounted automatic flow regulator** shall be set to 3 gpm/ton to deliver optimal flow to the unit.

### Refrigerant Circuit

All units shall utilize the non-ozone depleting and low global warming potential refrigerant R-410A. All units shall contain a sealed refrigerant circuit including a hermetic motor-compressor, bidirectional thermostatic expansion valve, finned tube air-to-refrigerant heat exchanger, reversing valve, coaxial tube water-to-refrigerant heat exchanger, and service ports.

Compressors shall be high-efficiency single speed rotary or reciprocating type designed for heat pump duty and mounted on vibration isolators. Compressor motors shall be single-phase PSC with overload protection.

The air coil shall be sized for low-face velocity and constructed of lanced aluminum fins bonded to rifled aluminum tubes in a staggered pattern not less than three rows deep for enhanced performance. The all-aluminum air coil is not susceptible to formicary corrosion.

**Option: AlumiSeal electro-coated air coil.**

The coaxial water-to-refrigerant heat exchanger shall be designed for low water pressure drop and constructed of a convoluted copper inner tube and a steel outer tube. Refrigerant to air heat exchangers shall utilize enhanced corrugated lanced aluminum fins and rifled copper tube construction rated to withstand 600 psig (4135 kPa) refrigerant working pressure. Refrigerant to water heat exchangers shall be of copper inner water tube and steel refrigerant outer tube design, rated to withstand 600 psig (4135 kPa) working refrigerant pressure and 450 psig (3101 kPa) working water pressure. The thermostatic expansion valve shall provide proper superheat over the entire liquid temperature range with minimal "hunting." The valve shall operate bidirectionally without the use of check valves.

**Option: Cupronickel refrigerant to water heat exchanger** shall be of copper-nickel inner water tube and steel refrigerant outer tube design, rated to withstand 600 psig (4135 kPa) working refrigerant pressure and 450 psig (3101 kPa) working water pressure. Water lines shall also be of cupronickel construction.

### Blower Motor and Assembly

The blower shall be a direct drive centrifugal type with a dynamically balanced wheel. The housing and wheel shall be designed for quiet low outlet velocity operation. The blower housing shall be removable from the unit without disconnecting the supply air ductwork for servicing of the blower motor. The blower motor shall be isolated from the housing by rubber grommets. The motor shall be permanently lubricated and have thermostatic overload protection.

Contractor: \_\_\_\_\_ P.O.: \_\_\_\_\_

Engineer: \_\_\_\_\_

Project Name: \_\_\_\_\_ Unit Tag: \_\_\_\_\_



## Engineering Guide Specifications cont.

### Blower Motor and Assembly

The blower shall be a direct drive centrifugal type with a dynamically balanced wheel. The housing and wheel shall be designed for quiet low outlet velocity operation. The blower housing shall be removable from the unit without disconnecting the supply air ductwork for servicing of the blower motor. The blower motor shall be isolated from the housing by rubber grommets. The motor shall be permanently lubricated and have thermostatic overload protection.

**Option: PSC blower motor** shall be a three-speed PSC type.

**Option: 5-Speed ECM blower motor** shall be a 5-speed ECM ECM type. The 5-speed ECM blower motor shall be soft starting, shall maintain constant torque over its operating static range, and shall provide 5 speed settings. The blower motor shall be isolated from the housing by rubber grommets. The motor shall be permanently lubricated and have thermostatic overload protection. 5-speed ECM motors shall be long-life ball bearing type.

**Option: Variable Speed ECM blower motor** shall be a variable-speed ECM type. The variable speed ECM blower motor shall be soft starting, shall maintain constant cfm over its operating static range, and shall provide 12 cfm settings. Variable speed ECM motors shall be long-life ball bearing type.

### Electrical

A control box shall be located within the unit compressor compartment and shall contain a 50VA or 75VA transformer, 24 volt activated, 2 pole compressor contactor, terminal block for thermostat wiring and solid-state controller for complete unit operation. Electromechanical operation WILL NOT be accepted. Units shall be name-plated for use with time delay fuses or HACR circuit breakers. Unit controls shall be 24 volt and provide heating or cooling as required by the remote thermostat/sensor.

An Aurora microprocessor-based controller that interfaces with a multi-stage electronic thermostat to monitor and control unit operation shall be provided. The control shall provide operational sequencing, blower speed control, high and low pressure switch monitoring, freeze detection, condensate overflow sensing, lockout mode control, LED status and fault indicators, fault memory, field selectable options and accessory output. The control shall provide fault retry three times before locking out to limit nuisance trips.

A detachable terminal block with screw terminals will be provided for field control wiring. All units shall have knockouts for entrance of low and line voltage wiring. The blower motor and control box shall be harness plug wired for easy removal.

The manufacturer works continually to improve its products. As a result, the design and specifications of each product at the time of order may be changed without notice. Purchaser's approval of this data set signifies that the equipment is acceptable under the provisions of the job specification. Statements and other information contained herein are not express warranties and do not form the basis of any bargain between the parties, but are merely the manufacturer's opinion or commendation of its products.

**Option: An Aurora Unitary Protocol Converter (UPC) shall be included** that communicates directly with the Aurora Heat Pump Controls and allows access/control of a variety of internal Aurora heat pump operations such as sensors, relay operation, faults and other information. In turn, the UPC shall convert the internal Aurora Modbus protocol to BACnet MS/TP, or N2 protocols for communication over a BAS system. Additional individual unit configuration items such as ECM fan speeds or freeze protection settings shall be directly available over the BAS without the need for access to the actual heat pump.

**Option: Aurora UPC DDC communication protocols: LonWorks**

### Piping

Supply and return water connections shall be FPT copper fittings.

With vertical units, the condensate connection shall be a 3/4 in. [19.1 mm] PVC socket with internally-trapped hose that can be routed to front or side corner post locations.

### Hanger Kit

**(included with horizontal units only - field installed)**

The hanger kit shall consist of galvanized steel brackets, bolts, lock washers, and isolators and shall be designed to fasten to the unit bottom panel for suspension from 3/8 in. threaded rods. Brackets shall not inhibit filter removal in any way.

### Accessories

**Thermostat (field-installed)**

A multi-stage auto-changeover electronic digital thermostat shall be provided. The thermostat shall offer two heating stages and one cooling stage with precise temperature control. An OFF-HEAT-AUTO-COOL-EMERG system switch, OFF-AUTO blower switch, and indicating LEDs shall be provided. The thermostat shall display in °F or °C.

Contractor: \_\_\_\_\_ P.O.: \_\_\_\_\_

Engineer: \_\_\_\_\_

Project Name: \_\_\_\_\_ Unit Tag: \_\_\_\_\_



## Engineering Guide Specifications cont.

### Hose Kits – Ball Valves (field-installed)

A flexible steel braid hose featuring Kevlar® reinforced EPDM core with ANSI 302/304 stainless steel outer braid and fire rated materials per ASTM E 84-00 (NFPA 255, ANSI/UL 723 & UBC 8-1). Ball valve at one end; swivel connector with adapter at the other end (swivel to adapter connection via fiber or EPDM gasket). Swivel connection provides union between heat pump and piping system. The hoses feature brass fittings, stainless steel ferrules. A full port ball valve shall be provided with integral P/T (pressure/temperature) port on supply hose.

#### Specifications:

- Temperature range of 35°F [2°C] to 180°F [82°C].
- Max. working pressure of 400 psi [2757 kPa] for 1/2 in. and 3/4 in. hose kits; max. working pressure of 350 psi [kPa] for 1 in. and 1-1/4 in. hose kits.

### Hose Kits – Automatic Balancing and Ball Valves (field-installed)

A flexible steel braid hose featuring Kevlar® reinforced EPDM core with ANSI 302/304 stainless steel outer braid

and fire rated materials per ASTM E 84-00 (NFPA 255, ANSI/UL 723 & UBC 8-1). Ball valve at one end; swivel connector with adapter at the other end (swivel to adapter connection via fiber or EPDM gasket). Swivel connection provides union between heat pump and piping system. The hoses feature brass fittings, stainless steel ferrules. A full port ball valve shall be provided with integral P/T (pressure/temperature) port on supply hose and automatic balancing valve with integral P/T ports and full port ball valve on return hose.

#### Specifications:

- Temperature range of 35°F [2°C] to 180°F [82°C]
- Max. working pressure of 400 psi [2757 kPa] for 1/2 in. and 3/4 in. hose kits; max. working pressure of 350 psi [2413 kPa] for 1 in. and 1-1/4 in. hose kits
- Minimum burst pressure of four times working pressure

### Hose Kits – Automatic Balancing and Ball Valves with ‘Y’ strainer (field-installed)

A flexible steel braid hose featuring Kevlar® reinforced EPDM core with ANSI 302/304 stainless steel outer braid and fire rated materials per ASTM E 84-00 (NFPA 255, ANSI/UL 723 & UBC 8-1). Ball valve at one end; swivel connector with adapter at the other end (swivel to adapter connection via fiber or EPDM gasket). Swivel connection provides union between heat pump and piping system. The hoses feature brass fittings, stainless steel ferrules. A “y” strainer is provided on one end for fluid straining and integral “blowdown” valve. A full port ball valve shall be provided with integral P/T (pressure/temperature) port on supply hose and automatic balancing valve with integral P/T ports and full port ball valve on return hose.

#### Specifications:

- Temperature range of 35°F [2°C] to 180°F [82°C]
- Max. working pressure of 400 psi [2756 kPa] for 1/2 in. and 3/4 in. hose kits; max. working pressure of 350 psi [2413 kPa] for 1 in. and 1-1/4 in. hose kits
- Minimum burst pressure of four times working pressure

Contractor: \_\_\_\_\_ P.O.: \_\_\_\_\_

Engineer: \_\_\_\_\_

Project Name: \_\_\_\_\_ Unit Tag: \_\_\_\_\_



## Revision Guide

---

Pages:	Description:	Date:	By:
Misc	Added 041 Vertical, Removed FX10 Control Option	16 Jan 2016	MA
All	Updated with CuproNickel Water Coil Option	20 May 2014	DS
All	Updated with All-Aluminum Air Coils	09 Oct 2013	DS
All	First Published	08 Apr 2013	DS