



Aston Series Console

GEOHERMAL HEAT PUMPS

0.75 TO 1.5 TONS

Submittal Data
English Language
IP/Metric Units
SD1010CG 02/11

GEOSTAR

Contractor: _____ P.O.: _____

Engineer: _____

Project Name: _____ Unit Tag: _____

Aston Series Console
0.75 - 1.5 Tons 60Hz



Model Nomenclature

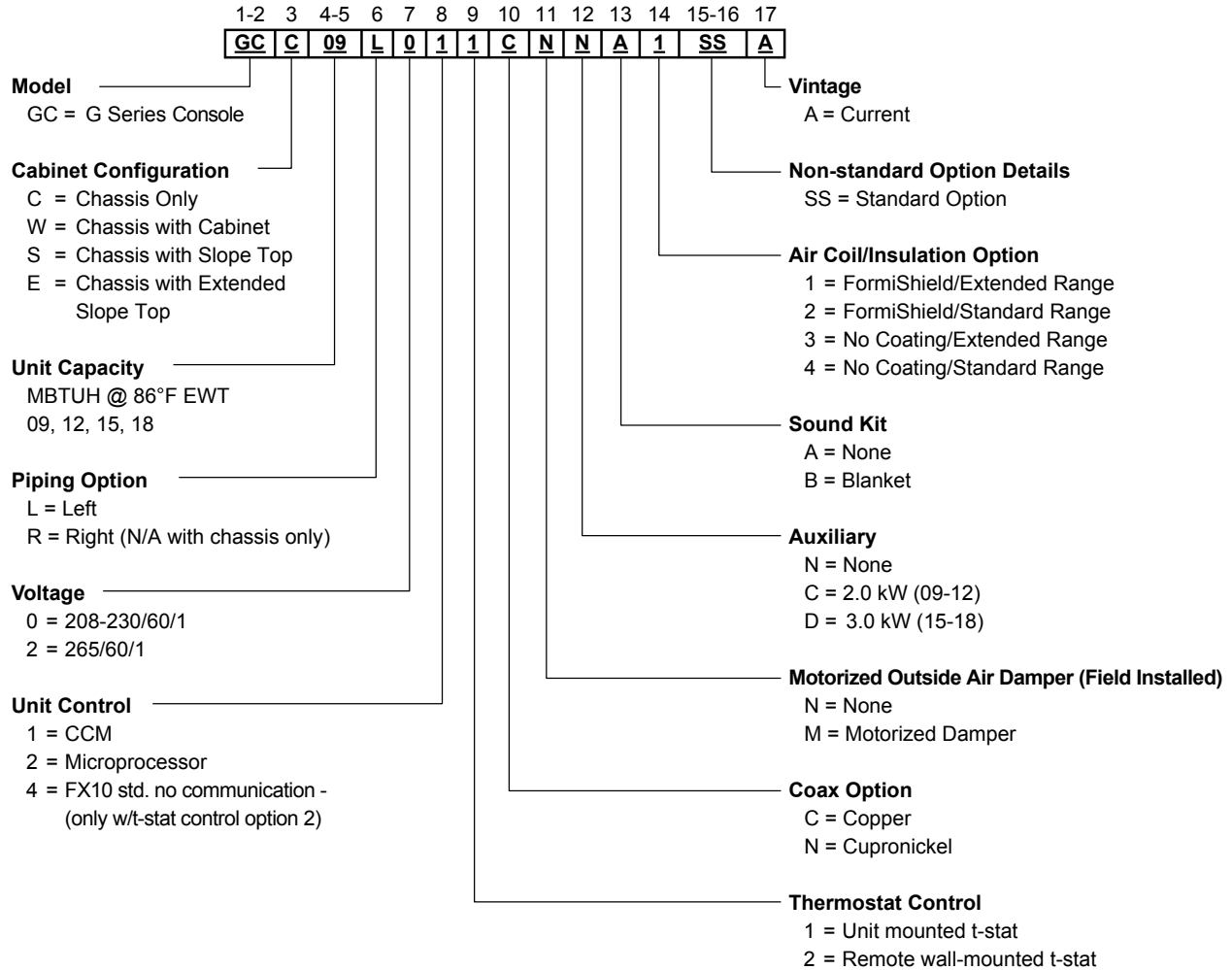

All G Series product is Safety listed under UL1995 thru ETL and performance listed with AHRI in accordance with standard 13256-1.

The manufacturer works continually to improve its products. As a result, the design and specifications of each product at the time of order may be changed without notice. Purchaser's approval of this data set signifies that the equipment is acceptable under the provisions of the job specification. Statements and other information contained herein are not express warranties and do not form the basis of any bargain between the parties, but are merely the manufacturer's opinion or commendation of its products.

Contractor: _____ P.O.: _____

Engineer: _____

Project Name: _____ Unit Tag: _____



AHRI Data

PSC Motors

AHRI/ASHRAE/ISO 13256-1
English (IP) Units

| Model | Flow Rate | | Water Loop Heat Pump | | | | Ground Water Heat Pump | | | | Ground Loop Heat Pump | | | |
|-------|-----------|-----|----------------------|---------------|---------------------|-----|------------------------|---------------|---------------------|-----|-----------------------|---------------|---------------------|-----|
| | | | Cooling EWT 86°F | | Heating EWT 68°F | | Cooling EWT 59°F | | Heating EWT 50°F | | Cooling EWT 77°F | | Heating EWT 32°F | |
| | gpm | cfm | Capacity Btuh | EER Btuh/W | Capacity Btuh | COP | Capacity Btuh | EER Btuh/W | Capacity Btuh | COP | Capacity Btuh | EER Btuh/W | Capacity Btuh | COP |
| 09 | 2.5 | 300 | 8,500 | 13.4 | 10,500 | 4.4 | 10,200 | 22.5 | 8,700 | 3.8 | 9,000 | 16.0 | 6,700 | 3.1 |
| 12 | 3.5 | 350 | 10,500 | 12.3 | 14,400 | 4.3 | 12,400 | 19.5 | 11,800 | 3.7 | 11,000 | 14.2 | 9,500 | 3.5 |
| 15 | 4.5 | 450 | 13,500 | 13.6 | 17,000 | 4.9 | 16,200 | 22.0 | 14,000 | 4.1 | 14,200 | 15.9 | 10,500 | 3.4 |
| 18 | 5.5 | 500 | 16,200 | 12.5 | 21,000 | 4.4 | 19,000 | 19.6 | 17,000 | 3.7 | 16,600 | 15.1 | 13,300 | 3.1 |

Cooling capacities based upon 80.6°F DB, 66.2°F WB entering air temperature
Heating capacities based upon 68°F DB, 59°F WB entering air temperature
All ratings based upon operation at the lower voltage of dual voltage rated models.

12/14/09

Energy Star Compliance Table

| Model | Tier 1 | | Tier 2 | |
|-------|--------------|-------------|--------------|-------------|
| | Ground Water | Ground Loop | Ground Water | Ground Loop |
| 09 | Yes | No | Yes | No |
| 12 | Yes | Yes | No | No |
| 15 | Yes | Yes | Yes | No |
| 18 | Yes | Yes | No | No |

12/17/10

Energy Star Rating Criteria

In order for water-source heat pumps to be Energy Star rated they must meet or exceed the minimum efficiency requirements listed below. Please note there are 3 Tier levels that dictate minimum efficiency for water-to-air heat pumps. Only one tier level is active at a given moment.

Tier 1: 12/1/2009 – 12/31/2010

| | EER | COP |
|----------------------------|------|-----|
| Closed loop water-to-air | 14.1 | 3.3 |
| Open loop water-to-air | 16.2 | 3.6 |
| Closed loop water-to-water | 15.1 | 3.0 |
| Open loop water-to-water | 19.1 | 3.4 |

Tier 2: 1/1/2011 – 12/31/2011

| | EER | COP |
|----------------------------|------|-----|
| Closed loop water-to-air | 16.1 | 3.5 |
| Open loop water-to-air | 18.2 | 3.8 |
| Closed loop water-to-water | 15.1 | 3.0 |
| Open loop water-to-water | 19.1 | 3.4 |

Tier 3: 1/1/2012 – No Effective End Date Published

| | EER | COP |
|----------------------------|------|-----|
| Closed loop water-to-air | 17.1 | 3.6 |
| Open loop water-to-air | 21.1 | 4.1 |
| Closed loop water-to-water | 16.1 | 3.1 |
| Open loop water-to-water | 20.1 | 3.5 |

Contractor: _____ P.O.: _____

Engineer: _____

Project Name: _____ Unit Tag: _____

Aston Series Console
0.75 - 1.5 Tons 60Hz



Dimensional Data - Flat Top Cabinet

GCW09-18

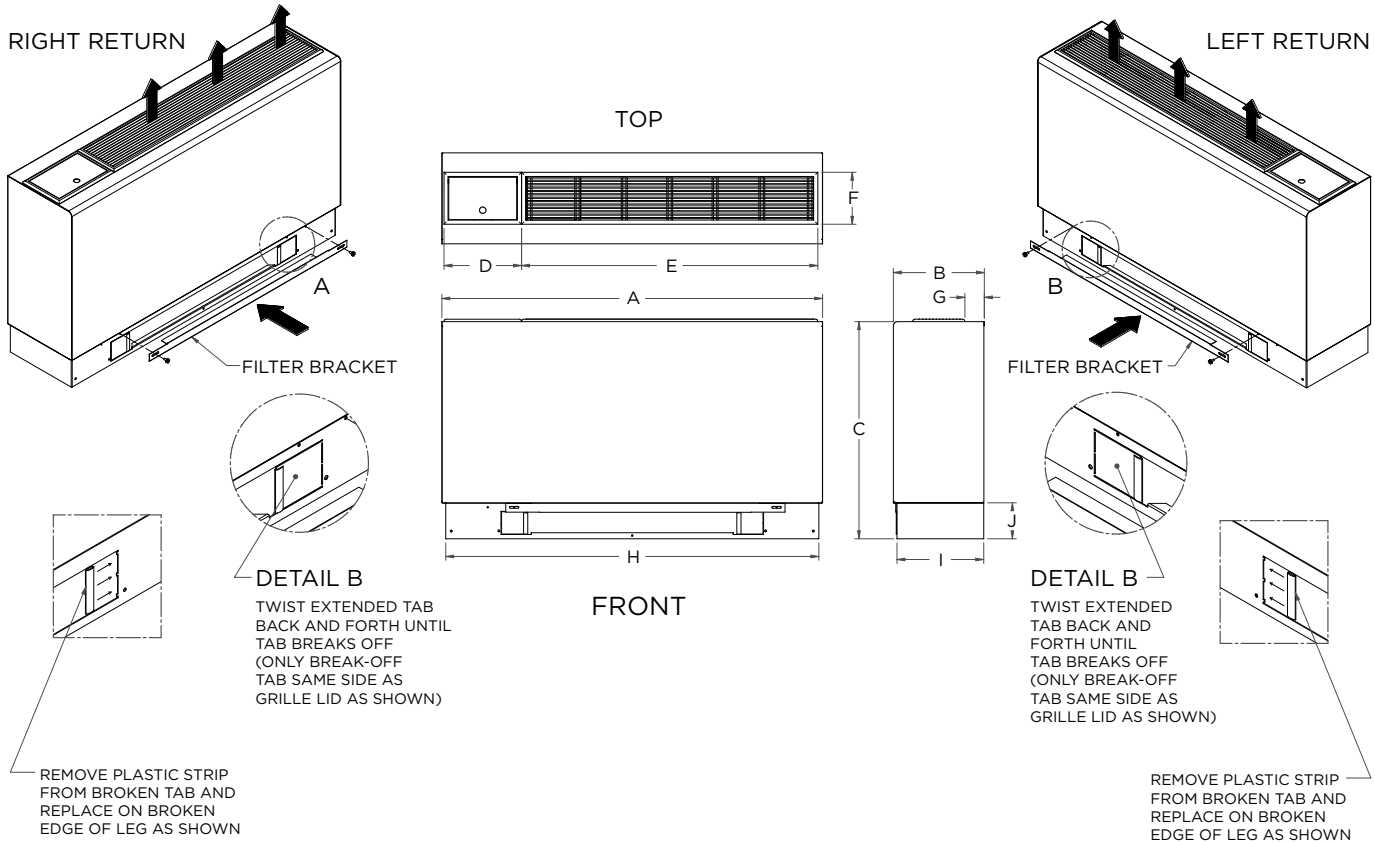

| Flat Top Configuration | | Overall Cabinet | | | | | | | | | |
|------------------------|-----|-----------------|-------|--------|------------|---------------|--------------|-----|-------|------|------|
| | | A | B | C | D | E | F | G | H | I | J |
| | | Width | Depth | Height | Grille Lid | Grille Length | Grille Width | | | | |
| 09-12 | in. | 45.0 | 10.8 | 25.7 | 9.2 | 35.0 | 6.1 | 2.3 | 44.1 | 10.3 | 4.3 |
| | cm. | 114.3 | 27.3 | 65.2 | 23.4 | 88.9 | 15.6 | 5.8 | 112.0 | 26.0 | 10.9 |
| 15-18 | in. | 50.0 | 12.3 | 25.7 | 9.2 | 35.0 | 6.1 | 3.3 | 49.1 | 11.8 | 4.3 |
| | cm. | 127.0 | 31.1 | 65.2 | 23.4 | 88.9 | 15.6 | 8.3 | 124.7 | 29.8 | 10.9 |

The manufacturer works continually to improve its products. As a result, the design and specifications of each product at the time of order may be changed without notice. Purchaser's approval of this data set signifies that the equipment is acceptable under the provisions of the job specification. Statements and other information contained herein are not express warranties and do not form the basis of any bargain between the parties, but are merely the manufacturer's opinion or commendation of its products.

Contractor: _____ P.O.: _____

Engineer: _____

Project Name: _____ Unit Tag: _____

Aston Series Console
0.75 - 1.5 Tons 60Hz



Dimensional Data - Slope Top Cabinet

GCS09-18

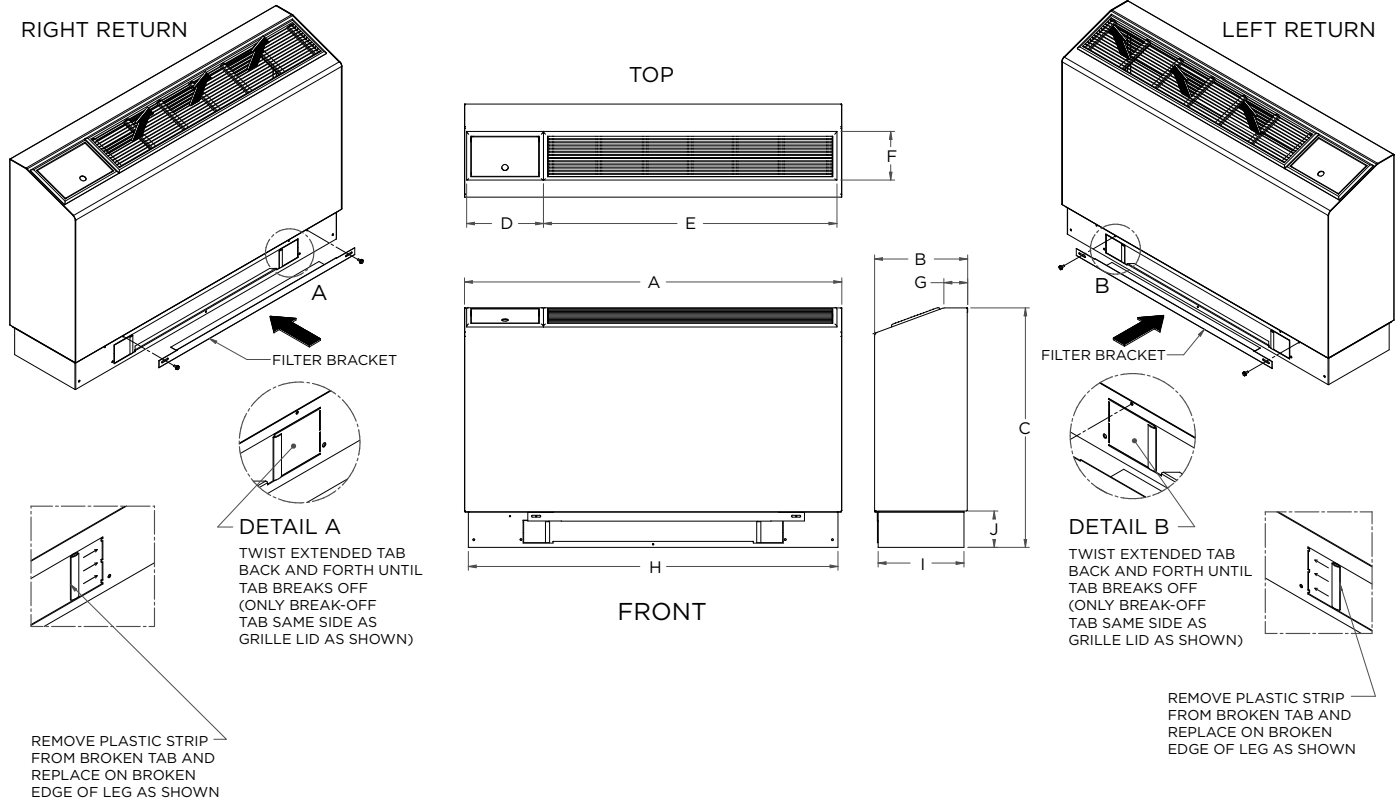

| Slope Top Configuration | | Overall Cabinet | | | | | | | | | |
|-------------------------|-----|-----------------|-------|--------|------------|---------------|--------------|-----|-------|------|------|
| | | A | B | C | D | E | F | G | H | I | J |
| | | Width | Depth | Height | Grille Lid | Grille Length | Grille Width | | | | |
| 09-12 | in. | 45.0 | 11.1 | 28.6 | 9.2 | 35.0 | 6.1 | 2.8 | 44.1 | 10.3 | 4.3 |
| | cm. | 114.3 | 28.2 | 72.6 | 23.4 | 88.9 | 15.6 | 7.2 | 112.0 | 26.0 | 10.9 |
| 15-18 | in. | 50.0 | 12.6 | 29.1 | 9.2 | 35.0 | 6.1 | 2.5 | 49.1 | 11.8 | 4.3 |
| | cm. | 127.0 | 32.0 | 73.9 | 23.4 | 88.9 | 15.6 | 6.4 | 124.7 | 29.8 | 10.9 |

The manufacturer works continually to improve its products. As a result, the design and specifications of each product at the time of order may be changed without notice. Purchaser's approval of this data set signifies that the equipment is acceptable under the provisions of the job specification. Statements and other information contained herein are not express warranties and do not form the basis of any bargain between the parties, but are merely the manufacturer's opinion or commendation of its products.

Contractor: _____ P.O.: _____

Engineer: _____

Project Name: _____ Unit Tag: _____

Aston Series Console
0.75 - 1.5 Tons 60Hz



Dimensional Data - Extended Slope Top Cabinet

GCE09-18

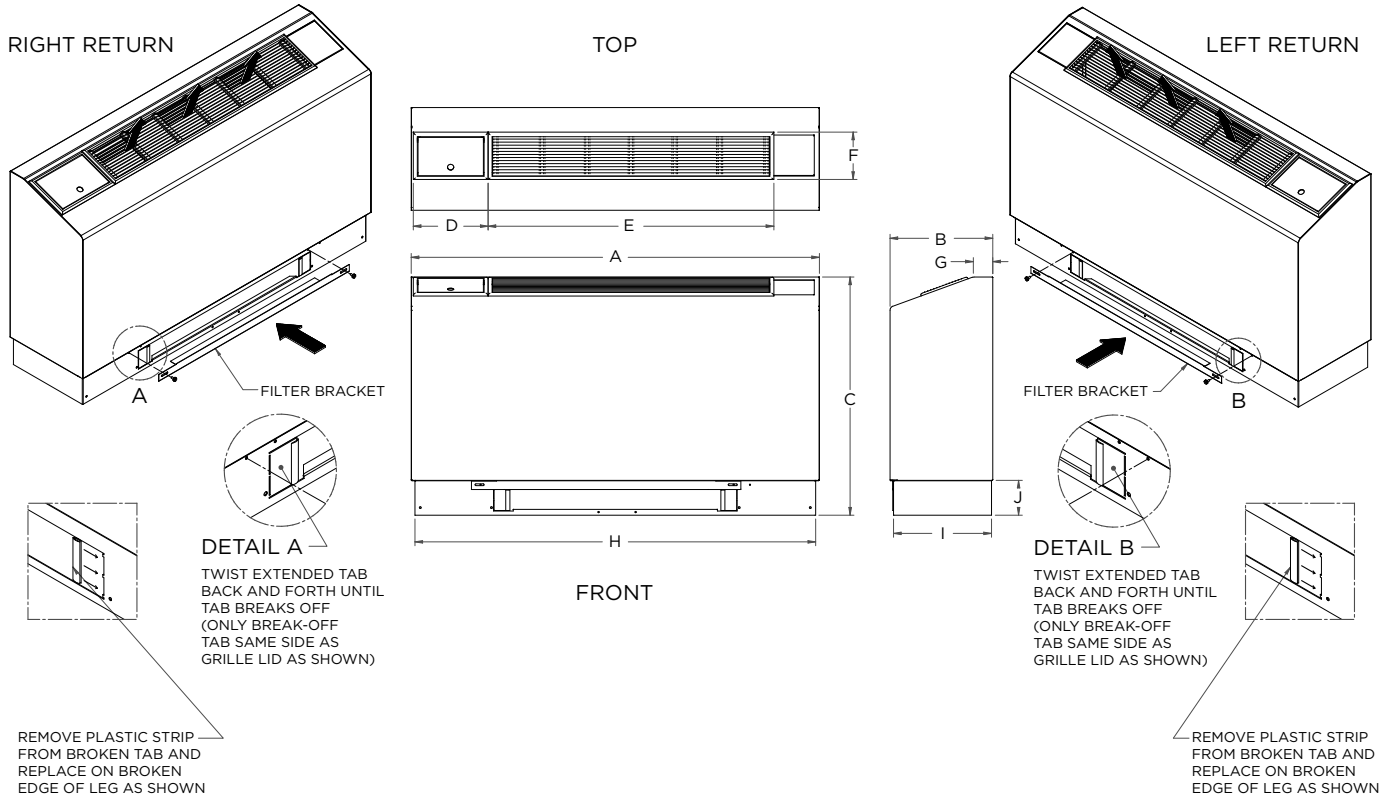

| Ext. Slope Top Configuration | | Overall Cabinet | | | | | | | | | |
|------------------------------|-----|-----------------|-------|--------|------------|---------------|--------------|-----|-------|------|------|
| | | A | B | C | D | E | F | G | H | I | J |
| | | Width | Depth | Height | Grille Lid | Grille Length | Grille Width | | | | |
| 09-12 | in. | 50.0 | 12.6 | 29.1 | 9.2 | 35.0 | 6.1 | 2.4 | 49.1 | 12.0 | 4.3 |
| | cm. | 127.0 | 32.0 | 73.9 | 23.4 | 88.9 | 15.6 | 6.1 | 124.7 | 30.5 | 10.9 |
| 15-18 | in. | 55.0 | 12.6 | 29.1 | 9.2 | 35.0 | 6.1 | 2.5 | 54.1 | 11.8 | 4.3 |
| | cm. | 139.7 | 32.0 | 73.9 | 23.4 | 88.9 | 15.6 | 6.4 | 137.4 | 29.8 | 10.9 |

The manufacturer works continually to improve its products. As a result, the design and specifications of each product at the time of order may be changed without notice. Purchaser's approval of this data set signifies that the equipment is acceptable under the provisions of the job specification. Statements and other information contained herein are not express warranties and do not form the basis of any bargain between the parties, but are merely the manufacturer's opinion or commendation of its products.

Contractor: _____ P.O.: _____

Engineer: _____

Project Name: _____ Unit Tag: _____

Aston Series Console
0.75 - 1.5 Tons 60Hz



Dimensional Data - Right Return Controls Detail

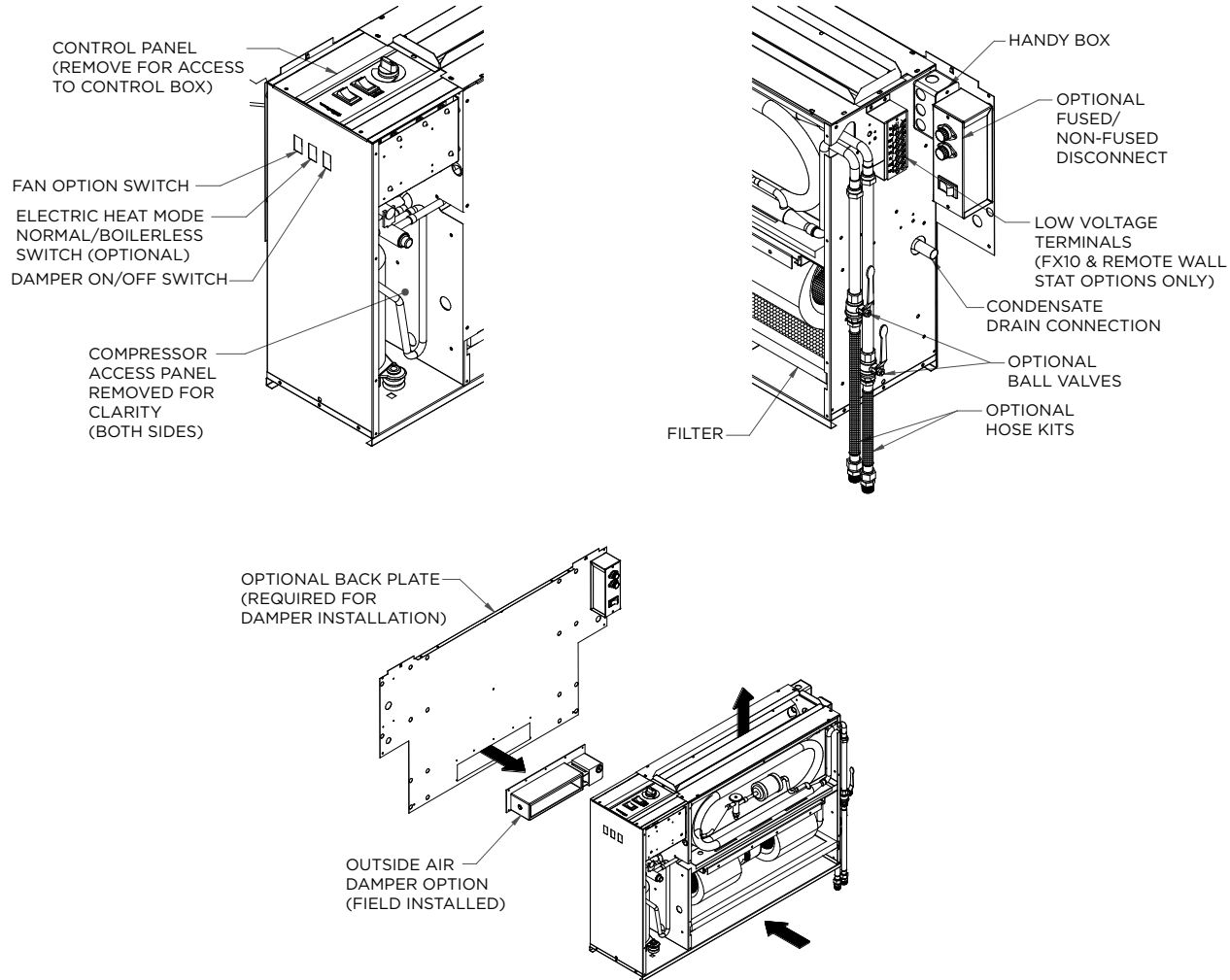

The manufacturer works continually to improve its products. As a result, the design and specifications of each product at the time of order may be changed without notice. Purchaser's approval of this data set signifies that the equipment is acceptable under the provisions of the job specification. Statements and other information contained herein are not express warranties and do not form the basis of any bargain between the parties, but are merely the manufacturer's opinion or commendation of its products.

Contractor: _____ P.O.: _____

Engineer: _____

Project Name: _____ Unit Tag: _____

Aston Series Console
0.75 - 1.5 Tons 60Hz



Dimensional Data - Right Return Chassis

Data = inches (cm)

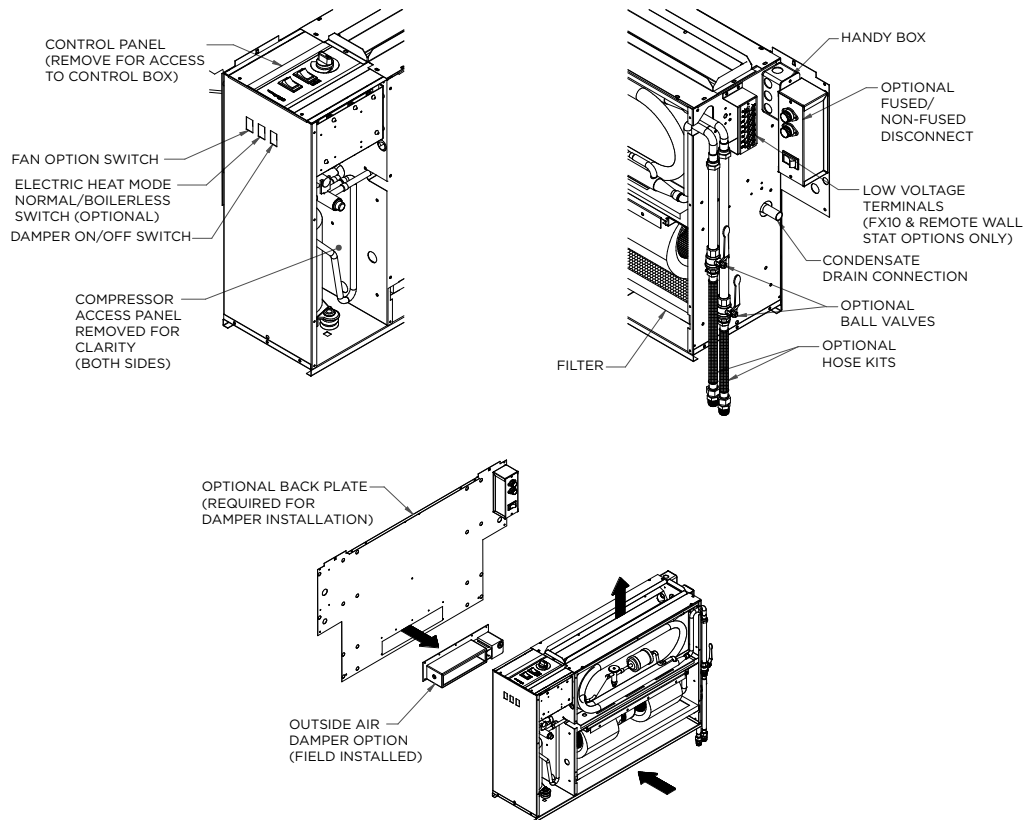

The manufacturer works continually to improve its products. As a result, the design and specifications of each product at the time of order may be changed without notice. Purchaser's approval of this data set signifies that the equipment is acceptable under the provisions of the job specification. Statements and other information contained herein are not express warranties and do not form the basis of any bargain between the parties, but are merely the manufacturer's opinion or commendation of its products.

Contractor: _____ P.O.: _____

Engineer: _____

Project Name: _____ Unit Tag: _____

Aston Series Console
0.75 - 1.5 Tons 60Hz



Dimensional Data - Left Return Controls Detail

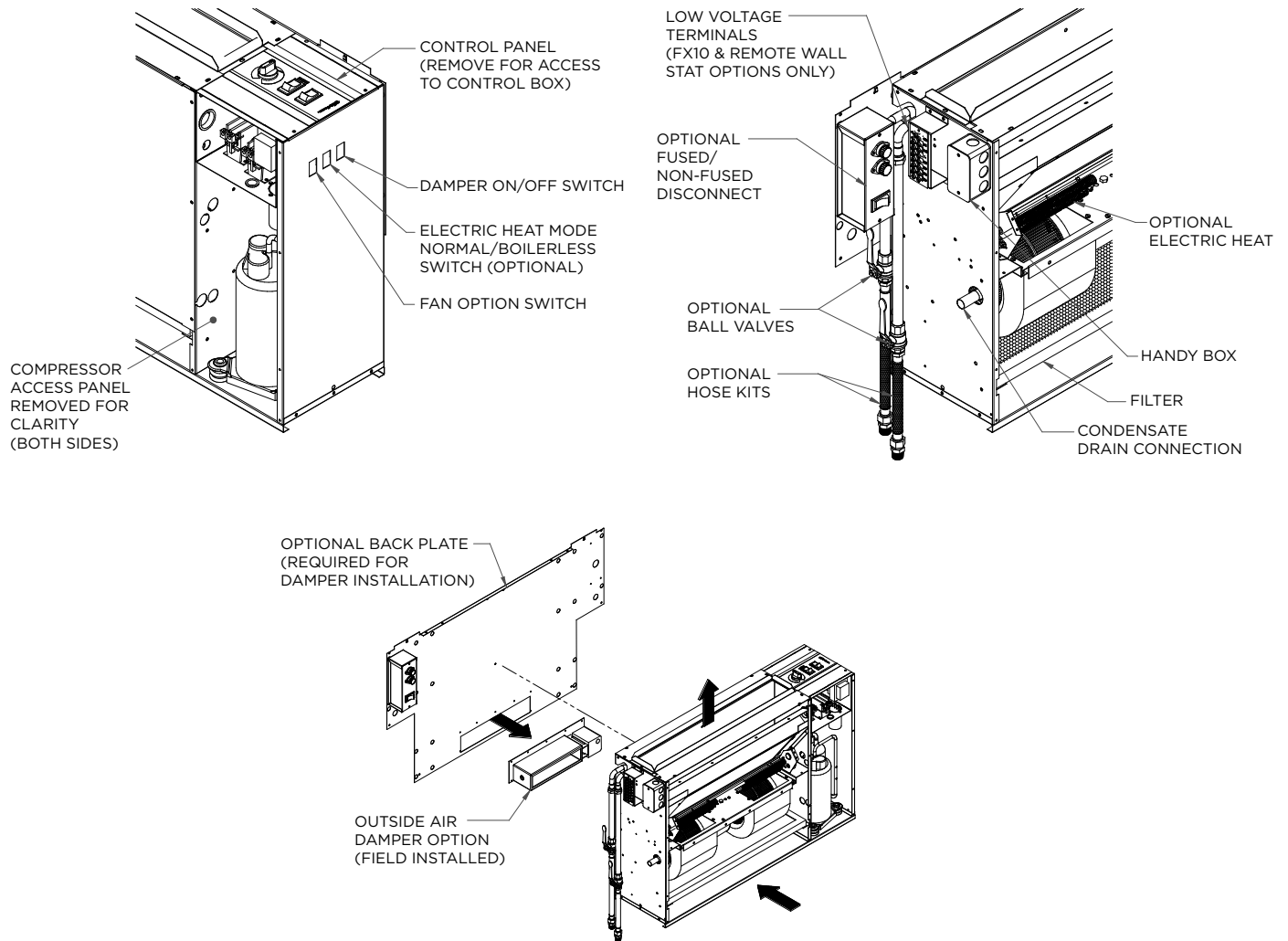

The manufacturer works continually to improve its products. As a result, the design and specifications of each product at the time of order may be changed without notice. Purchaser's approval of this data set signifies that the equipment is acceptable under the provisions of the job specification. Statements and other information contained herein are not express warranties and do not form the basis of any bargain between the parties, but are merely the manufacturer's opinion or commendation of its products.

Contractor: _____ P.O.: _____

Engineer: _____

Project Name: _____ Unit Tag: _____

Aston Series Console
0.75 - 1.5 Tons 60Hz



Dimensional Data - Left Return Chassis

Data = inches (cm)

Models 09-12

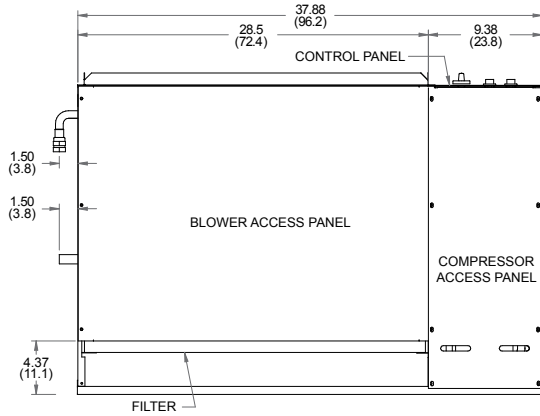

Models 15-18

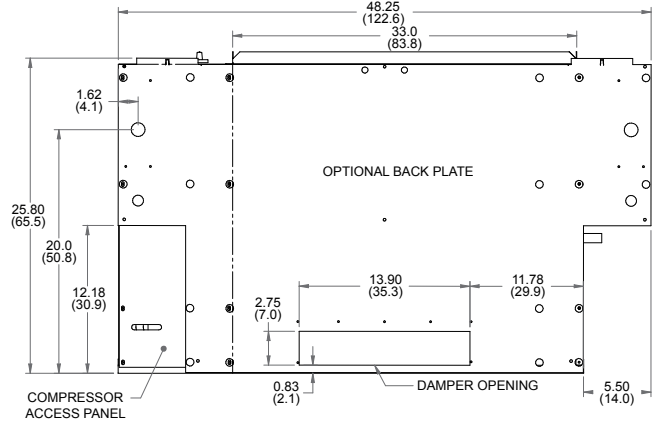
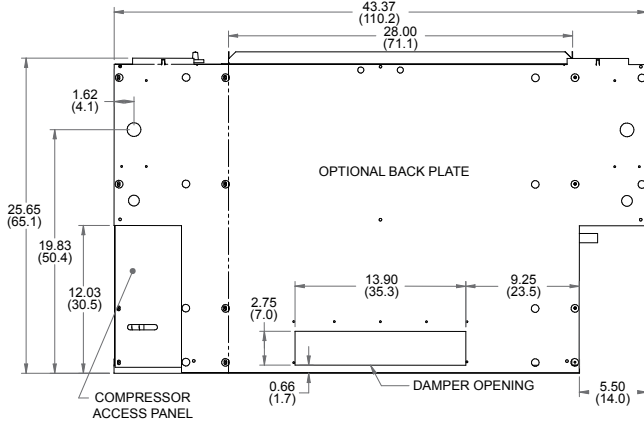
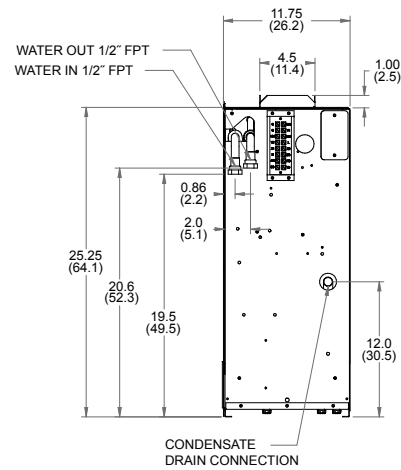
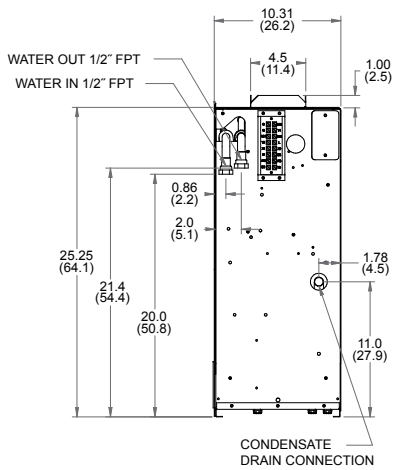
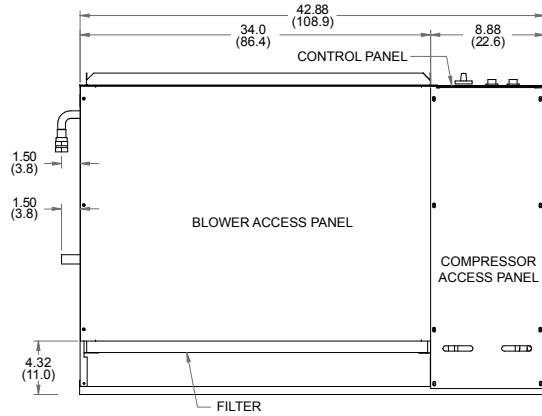

The manufacturer works continually to improve its products. As a result, the design and specifications of each product at the time of order may be changed without notice. Purchaser's approval of this data set signifies that the equipment is acceptable under the provisions of the job specification. Statements and other information contained herein are not express warranties and do not form the basis of any bargain between the parties, but are merely the manufacturer's opinion or commendation of its products.

Contractor: _____ P.O.: _____

Aston Series Console
0.75 - 1.5 Tons 60Hz

Engineer: _____

Project Name: _____ Unit Tag: _____



Physical Data

| Model | Consoles | | | |
|---|----------------------------|----------------------------|----------------------------|----------------------------|
| | 09 | 12 | 15 | 18 |
| Compressor (1 each) | LG Rotary | | | |
| Factory Charge R410A, oz [kg] | 25 [0.71] | 29 [0.82] | 38 [1.08] | 34 [0.96] |
| Blower Motor & Blower | PSC 2 Speeds | | | |
| Blower Motor Type/Speeds | PSC 2 Speeds | | | |
| Blower Motor- hp [W] | 1/20 [37] | 1/20 [37] | 1/12 [62] | 1/12 [62] |
| Blower Wheel Size (Dia x W), in. [mm] | 5.75 x 5.5 [146 x 140] | 5.75 x 5.5 [146 x 140] | 6.0 x 6.5 [152 x 165] | 6.0 x 6.5 [152 x 165] |
| Coax and Water Piping | | | | |
| Water Connections Size - FPT - in [mm] | 1/2" [12.7] | 1/2" [12.7] | 1/2" [12.7] | 1/2" [12.7] |
| Coax & Piping Water Volume - gal [l] | 0.15 [0.6] | 0.18 [0.7] | 0.35 [1.3] | 0.35 [1.3] |
| Consoles | | | | |
| Air Coil Dimensions (H x W), in. [mm] | 8 x 22 [203 x 559] | 8 x 22 [203 x 559] | 8 x 30 [203 x 762] | 8 x 30 [203 x 762] |
| Air Coil Total Face Area, ft2 [m2] | 1.2 [0.114] | 1.2 [0.114] | 1.7 [0.155] | 1.7 [0.155] |
| Air Coil Tube Size, in [mm] | 3/8 [9.5] | 3/8 [9.5] | 3/8 [9.5] | 3/8 [9.5] |
| Air Coil Number of rows | 3 | 3 | 4 | 4 |
| Filter Standard - 1" [25.4mm] Throwaway | 1 - 10 x 28 [254 x 711] | 1 - 10 x 28 [254 x 711] | 1 - 12 x 33 [305 x 838] | 1 - 12 x 33 [305 x 838] |
| Weight - Operating, lb [kg] | 210 [91] | 210 [95] | 230 [102] | 235 [107] |
| Weight - Packaged, lb [kg] | 220 [100] | 220 [100] | 240 [109] | 245 [111] |

3/4/08

Electrical Data

| Model | Rated Voltage | Voltage Min/Max | Compressor | | | Blower Motor FLA | Total Unit FLA | Min Circ Amp | Max Fuse/HACR |
|-------|---------------|-----------------|------------|-----|------|------------------|----------------|--------------|---------------|
| | | | MCC | RLA | LRA | | | | |
| 09 | 208-230/60/1 | 197/253 | 6.4 | 4.1 | 21.0 | 0.50 | 4.6 | 5.6 | 10 |
| | 265/60/1* | 238/292 | na | 4.3 | 22.0 | 0.50 | 4.8 | 5.9 | 10 |
| 12 | 208-230/60/1 | 197/253 | 7.7 | 4.9 | 25.0 | 0.50 | 5.4 | 6.7 | 10 |
| | 265/60/1* | 238/292 | na | 5.3 | 22.0 | 0.50 | 5.8 | 7.1 | 10 |
| 15 | 208-230/60/1 | 197/253 | 9.2 | 5.9 | 29.0 | 0.69 | 6.6 | 8.1 | 10 |
| | 265/60/1* | 238/292 | na | 5.6 | 28.0 | 0.65 | 6.3 | 7.7 | 10 |
| 18 | 208-230/60/1 | 197/253 | 10.4 | 6.7 | 33.5 | 0.69 | 7.3 | 9.0 | 15 |
| | 265/60/1* | 238/292 | na | 7.3 | 28.0 | 0.65 | 8.0 | 9.8 | 15 |

HACR circuit breaker in USA only

* RLA determine per UL1995 test procedure and not from compressor rating.

4/8/08

Auxiliary Heat Ratings

| Model | Rated Voltage | Voltage Min./Max. | Heater Element Watts | Blower Motor FLA | Heater Element FLA | Total Unit FLA | Min. Circuit Amp. | Max. Fuse/Brkr. |
|-------|---------------|-------------------|----------------------|------------------|--------------------|----------------|-------------------|-----------------|
| 09-12 | 208/60/1 | 197/254 | 2000 | 0.50 | 9.62 | 10.1 | 12.7 | 15 |
| | 230/60/1 | 197/254 | 2445 | 0.50 | 10.63 | 11.1 | 13.9 | 15 |
| | 265/60/1 | 239/292 | 2000 | 0.55 | 7.55 | 8.1 | 10.1 | 15 |
| 15-18 | 208/60/1 | 197/254 | 3000 | 0.69 | 14.42 | 15.1 | 18.9 | 20 |
| | 230/60/1 | 197/254 | 3668 | 0.69 | 15.95 | 16.6 | 20.8 | 25 |
| | 265/60/1 | 239/292 | 3000 | 0.65 | 11.32 | 12.0 | 15.0 | 15 |

Always refer to unit name plate data prior to installation.

3/4/08

The manufacturer works continually to improve its products. As a result, the design and specifications of each product at the time of order may be changed without notice. Purchaser's approval of this data set signifies that the equipment is acceptable under the provisions of the job specification. Statements and other information contained herein are not express warranties and do not form the basis of any bargain between the parties, but are merely the manufacturer's opinion or commendation of its products.

Contractor: _____ P.O.: _____

Engineer: _____

Project Name: _____ Unit Tag: _____



Blower Performance Data Pressure Drop

| Model | CFM | |
|-----------|-----------|------------|
| | Low Speed | High Speed |
| 09 | 300 | 350 |
| 12 | 300 | 350 |
| 15 | 450 | 500 |
| 18 | 450 | 500 |

Factory settings are in **Bold**
Air flow values are with dry coil and standard filter.

For wet coil performance first calculate the face velocity of the air coil (Face Velocity [fpm] = Airflow [cfm] / Face Area [sq ft]). Then for velocities of 200 fpm reduce the static capability by 0.03 in. wg, 300 fpm by 0.08 in. wg, 400 fpm by 0.12in. wg. and 500 fpm by 0.16 in. wg.

| Model | GPM | Pressure Drop (psi) | | | | |
|-----------|-----|---------------------|------|------|------|-------|
| | | 30°F | 50°F | 70°F | 90°F | 110°F |
| 09 | 1.2 | 1.0 | 0.9 | 0.8 | 0.7 | 0.6 |
| | 1.8 | 2.3 | 2.2 | 2.0 | 1.9 | 1.8 |
| | 2.5 | 3.8 | 3.7 | 3.5 | 3.3 | 3.1 |
| 12 | 1.5 | 0.9 | 0.8 | 0.7 | 0.6 | 0.5 |
| | 2.3 | 1.7 | 1.5 | 1.4 | 1.3 | 1.1 |
| | 3.5 | 3.0 | 2.7 | 2.5 | 2.4 | 2.2 |
| 15 | 2.0 | 1.7 | 1.6 | 1.5 | 1.4 | 1.3 |
| | 3.0 | 3.3 | 3.2 | 3.0 | 2.9 | 2.8 |
| | 4.5 | 5.7 | 5.5 | 5.3 | 5.1 | 4.9 |
| 18 | 3.0 | 1.7 | 1.6 | 1.5 | 1.4 | 1.3 |
| | 4.0 | 4.1 | 4.0 | 3.9 | 3.7 | 3.6 |
| | 5.5 | 7.9 | 7.6 | 7.4 | 7.2 | 6.9 |

12/14/09

Correction Factor Tables

Cooling Capacity Corrections

| Entering Air WB °F | Total Clg Cap | Sensible Cooling Capacity Multipliers - Entering DB °F | | | | | | | | | | Power Input | Heat of Rejection |
|--------------------|---------------|--|-------|-------|-------|--------------|-------|-------|-------|-------|-------|--------------|-------------------|
| | | 60 | 65 | 70 | 75 | 80 | 80.6 | 85 | 90 | 95 | 100 | | |
| 45 | 0.719 | 0.891 | 1.058 | 1.128 | * | * | * | * | * | * | * | 0.898 | 0.741 |
| 50 | 0.719 | 0.893 | 0.980 | 1.106 | * | * | * | * | * | * | * | 0.898 | 0.741 |
| 55 | 0.812 | 0.629 | 0.844 | 1.026 | 1.172 | * | * | * | * | * | * | 0.922 | 0.819 |
| 60 | 0.897 | | | 0.820 | 0.995 | 1.206 | 1.238 | * | * | * | * | 0.955 | 0.895 |
| 65 | 0.960 | | | 0.568 | 0.810 | 1.004 | 1.052 | 1.227 | * | * | * | 0.982 | 0.951 |
| 66.2 | 0.984 | | | 0.505 | 0.743 | 1.002 | 1.027 | 1.151 | * | * | * | 0.993 | 0.980 |
| 67 | 1.000 | | | 0.463 | 0.699 | 1.000 | 1.011 | 1.101 | 1.310 | * | * | 1.000 | 1.000 |
| 70 | 1.047 | | | | 0.599 | 0.865 | 0.879 | 1.007 | 1.225 | 1.433 | * | 1.018 | 1.029 |
| 75 | 1.148 | | | | | 0.567 | 0.584 | 0.734 | 0.956 | 1.261 | 1.476 | 1.056 | 1.118 |

Note: * Sensible capacity equals total capacity at conditions shown.

7/20/06

Heating Capacity Corrections

| Ent Air DB °F | Heating Corrections | | |
|---------------|---------------------|--------------|--------------|
| | Htg Cap | Power | Heat of Ext |
| 45 | 1.050 | 0.749 | 1.158 |
| 50 | 1.059 | 0.859 | 1.130 |
| 55 | 1.043 | 0.894 | 1.096 |
| 60 | 1.033 | 0.947 | 1.064 |
| 65 | 1.023 | 0.974 | 1.030 |
| 68 | 1.009 | 0.990 | 1.012 |
| 70 | 1.000 | 1.000 | 1.000 |
| 75 | 1.011 | 1.123 | 0.970 |
| 80 | 1.000 | 1.196 | 0.930 |

7/20/06

The manufacturer works continually to improve its products. As a result, the design and specifications of each product at the time of order may be changed without notice. Purchaser's approval of this data set signifies that the equipment is acceptable under the provisions of the job specification. Statements and other information contained herein are not express warranties and do not form the basis of any bargain between the parties, but are merely the manufacturer's opinion or commendation of its products.

Contractor: _____ P.O.: _____

Engineer: _____

Project Name: _____ Unit Tag: _____



Reference Calculations

| Heating Calculations: | Cooling Calculations: |
|--|--|
| $LWT = EWT - \frac{HE}{GPM \times 500}$ | $LWT = EWT + \frac{HR}{GPM \times 500}$ |
| $LAT = EAT + \frac{HC}{CFM \times 1.08}$ | $LAT (DB) = EAT (DB) - \frac{SC}{CFM \times 1.08}$ |
| $TH = HC + HW$ | $LC = TC - SC$ |
| | $S/T = \frac{SC}{TC}$ |

Legend

ABBREVIATIONS AND DEFINITIONS:

| | |
|---|---------------------------------------|
| CFM = airflow, cubic feet/minute | HE = total heat of extraction, MBTUH |
| EWT = entering water temperature, Fahrenheit | HW = desuperheater capacity, MBTUH |
| GPM = water flow in gallons/minute | EER = Energy Efficient Ratio |
| WPD = water pressure drop, PSI and feet of water | = BTU output/Watt input |
| EAT = entering air temperature, Fahrenheit (dry bulb/wet bulb) | COP = Coefficient of Performance |
| HC = air heating capacity, MBTUH | = BTU output/BTU input |
| TC = total cooling capacity, MBTUH | LWT = leaving water temperature, °F |
| SC = sensible cooling capacity, MBTUH | LAT = leaving air temperature, °F |
| KW = total power unit input, kilowatts | TH = total heating capacity, MBTUH |
| HR = total heat of rejection, MBTUH | LC = latent cooling capacity, MBTUH |
| | S/T = sensible to total cooling ratio |

Operating Limits

| Operating Limits | Cooling | | Heating | |
|--------------------------|-----------|---------|---------|------|
| | (°F) | (°C) | (°F) | (°C) |
| Air Limits | | | | |
| Min. Ambient Air | 45 | 7.2 | 45 | 7.2 |
| Rated Ambient Air | 80 | 26.7 | 70 | 21.1 |
| Max. Ambient Air | 100 | 37.8 | 85 | 29.4 |
| Min. Entering Air | 50 | 10.0 | 40 | 4.4 |
| Rated Entering Air db/wb | 80.6/66.2 | 27/19 | 68 | 20.0 |
| Max. Entering Air db/wb | 110/83 | 43/28.3 | 80 | 26.7 |
| Water Limits | | | | |
| Min. Entering Water | 30 | -1.1 | 20 | -6.7 |
| Normal Entering Water | 50-110 | 10-43.3 | 30-70 | -1.1 |
| Max. Entering Water | 120 | 48.9 | 90 | 32.2 |

NOTE: Minimum/maximum limits are only for start-up conditions, and are meant for bringing the space up to occupancy temperature. Units are not designed to operate at the minimum/maximum conditions on a regular basis. The operating limits are dependent upon three primary factors: 1) water temperature, 2) return air temperature, and 3) ambient temperature. When any of the factors are at the minimum or maximum levels, the other two factors must be at the normal level for proper and reliable unit operation.

Contractor: _____ P.O.: _____

Engineer: _____

Project Name: _____ Unit Tag: _____



Antifreeze Corrections

Catalog performance can be corrected for antifreeze use. Please use the following table and note the example given.

| Antifreeze Type | Antifreeze % by wt | Cooling Capacity | Heating Capacity | Pressure Drop |
|-------------------|--------------------|------------------|------------------|------------------|
| EWT - degF [DegC] | | 90 [32.2] | 30 [-1.1] | 30 [-1.1] |
| Water | 0 | 1.000 | 1.000 | 1.000 |
| Ethylene Glycol | 10 | 0.991 | 0.973 | 1.075 |
| | 20 | 0.979 | 0.943 | 1.163 |
| | 30 | 0.965 | 0.917 | 1.225 |
| | 40 | 0.955 | 0.890 | 1.324 |
| | 50 | 0.943 | 0.865 | 1.419 |
| Propylene Glycol | 10 | 0.981 | 0.958 | 1.130 |
| | 20 | 0.969 | 0.913 | 1.270 |
| | 30 | 0.950 | 0.854 | 1.433 |
| | 40 | 0.937 | 0.813 | 1.614 |
| | 50 | 0.922 | 0.770 | 1.816 |
| Ethanol | 10 | 0.991 | 0.927 | 1.242 |
| | 20 | 0.972 | 0.887 | 1.343 |
| | 30 | 0.947 | 0.856 | 1.383 |
| | 40 | 0.930 | 0.815 | 1.523 |
| | 50 | 0.911 | 0.779 | 1.639 |
| Methanol | 10 | 0.986 | 0.957 | 1.127 |
| | 20 | 0.970 | 0.924 | 1.197 |
| | 30 | 0.951 | 0.895 | 1.235 |
| | 40 | 0.936 | 0.863 | 1.323 |
| | 50 | 0.920 | 0.833 | 1.399 |

Warning: Gray area represents antifreeze concentrations greater than 35% by weight and should be avoided due to the extreme performance penalty they represent.

Antifreeze Correction Example

Antifreeze solution is Propylene Glycol 20% by weight. Determine the corrected heating and cooling performance at 30°F and 90°F respectively as well as pressure drop at 30°F for an G Series Console GC*18.

The corrected cooling capacity at 90°F would be: 17,100 MBtuh x 0.969 = 16,569 MBtuh

The corrected heating capacity at 30°F would be: 14,300 MBtuh x 0.913 = 13,056 MBtuh

The corrected pressure drop at 30°F and 5.5 GPM would be: 18.2 feet of head x 1.270 = 23.1 feet of head

Contractor: _____ P.O.: _____

Engineer: _____

Project Name: _____ Unit Tag: _____

Aston Series Console
0.75 - 1.5 Tons 60Hz



GC09 - Performance Data

300 Rated CFM Heating / Cooling

Performance capacities shown in thousands of Btuh.

| EWT °F | Flow Rate GPM | Water Pressure Drop | | HEATING - EAT 70 °F | | | | | COOLING - EAT 80/67 °F | | | | | |
|-----------|---------------------|------------------------|-------|---------------------------|-------------|-------------|-----------|------|---------------------------|-------------|--------------|-------------|-------------|------|
| | | PSI | FT/HD | HC kBtuh | Power kW | HE kBtuh | LAT °F | COP | TC kBtuh | SC kBtuh | S/T Ratio | Power kW | HR kBtuh | EER |
| | | | | | | | | | | | | | | |
| 20 | 1.2 | 1.1 | 2.5 | Operation not recommended | | | | | Operation not recommended | | | | | |
| | 1.8 | 2.4 | 5.6 | Operation not recommended | | | | | Operation not recommended | | | | | |
| | 2.5 | 3.8 | 8.8 | 6.8 | 0.60 | 4.8 | 89.0 | 3.35 | Operation not recommended | | | | | |
| 30 | 1.2 | 1.0 | 2.3 | Operation not recommended | | | | | Operation not recommended | | | | | |
| | 1.8 | 2.3 | 5.4 | 6.9 | 0.60 | 4.8 | 89.3 | 3.38 | 12.1 | 7.3 | 0.61 | 0.38 | 13.4 | 31.8 |
| | 2.5 | 3.8 | 8.8 | 7.3 | 0.63 | 5.1 | 90.5 | 3.40 | 12.2 | 7.4 | 0.61 | 0.36 | 13.4 | 33.9 |
| 40 | 1.2 | 1.0 | 2.2 | 7.6 | 0.62 | 5.5 | 91.5 | 3.63 | Operation not recommended | | | | | |
| | 1.8 | 2.3 | 5.2 | 7.9 | 0.62 | 5.8 | 92.4 | 3.72 | 11.5 | 7.1 | 0.62 | 0.41 | 12.9 | 28.1 |
| | 2.5 | 3.8 | 8.7 | 8.3 | 0.64 | 6.1 | 93.7 | 3.80 | 11.6 | 7.2 | 0.62 | 0.39 | 12.9 | 30.0 |
| 50 | 1.2 | 0.9 | 2.1 | 8.8 | 0.65 | 6.6 | 95.2 | 4.00 | 10.7 | 6.8 | 0.63 | 0.45 | 12.3 | 23.6 |
| | 1.8 | 2.2 | 5.1 | 9.1 | 0.65 | 6.9 | 96.0 | 4.08 | 10.9 | 6.9 | 0.63 | 0.44 | 12.3 | 24.9 |
| | 2.5 | 3.7 | 8.5 | 9.4 | 0.66 | 7.1 | 97.0 | 4.17 | 11.0 | 7.0 | 0.64 | 0.41 | 12.4 | 26.6 |
| 60 | 1.2 | 0.9 | 2.0 | 10.3 | 0.68 | 8.0 | 99.8 | 4.46 | 10.4 | 6.7 | 0.64 | 0.52 | 12.1 | 19.9 |
| | 1.8 | 2.1 | 4.9 | 10.5 | 0.68 | 8.2 | 100.5 | 4.53 | 10.5 | 6.7 | 0.64 | 0.50 | 12.2 | 21.0 |
| | 2.5 | 3.6 | 8.3 | 10.8 | 0.69 | 8.5 | 101.3 | 4.60 | 10.7 | 6.9 | 0.64 | 0.47 | 12.3 | 22.4 |
| 70 | 1.2 | 0.8 | 1.8 | 11.8 | 0.71 | 9.4 | 104.5 | 4.88 | 10.0 | 6.5 | 0.65 | 0.59 | 12.0 | 17.1 |
| | 1.8 | 2.0 | 4.7 | 12.0 | 0.71 | 9.6 | 105.0 | 4.93 | 10.1 | 6.6 | 0.65 | 0.56 | 12.1 | 18.0 |
| | 2.5 | 3.5 | 8.1 | 12.2 | 0.72 | 9.8 | 105.7 | 4.99 | 10.3 | 6.7 | 0.65 | 0.54 | 12.1 | 19.2 |
| 80 | 1.2 | 0.8 | 1.7 | 12.7 | 0.73 | 10.2 | 107.3 | 5.11 | 9.5 | 6.3 | 0.67 | 0.65 | 11.7 | 14.5 |
| | 1.8 | 2.0 | 4.6 | 12.9 | 0.74 | 10.4 | 107.9 | 5.12 | 9.6 | 6.5 | 0.67 | 0.62 | 11.7 | 15.5 |
| | 2.5 | 3.4 | 7.9 | 13.1 | 0.75 | 10.5 | 108.4 | 5.13 | 9.9 | 6.5 | 0.66 | 0.60 | 11.9 | 16.4 |
| 90 | 1.2 | 0.7 | 1.6 | 13.6 | 0.76 | 11.0 | 110.0 | 5.24 | 9.2 | 6.1 | 0.67 | 0.72 | 11.6 | 12.7 |
| | 1.8 | 1.9 | 4.4 | 13.8 | 0.77 | 11.2 | 110.6 | 5.25 | 9.3 | 6.2 | 0.67 | 0.69 | 11.7 | 13.5 |
| | 2.5 | 3.3 | 7.6 | 14.0 | 0.78 | 11.3 | 111.2 | 5.26 | 9.4 | 6.3 | 0.67 | 0.67 | 11.7 | 14.1 |
| 100 | 1.2 | 0.7 | 1.5 | Operation not recommended | | | | | Operation not recommended | | | | | |
| | 1.8 | 1.8 | 4.3 | | | | | | 9.0 | 6.0 | 0.67 | 0.76 | 11.6 | 11.8 |
| | 2.5 | 3.2 | 7.4 | | | | | | 9.1 | 6.1 | 0.67 | 0.74 | 11.6 | 12.3 |
| 110 | 1.2 | 0.6 | 1.5 | | | | | | Operation not recommended | | | | | |
| | 1.8 | 1.8 | 4.1 | | | | | | 8.6 | 5.8 | 0.67 | 0.83 | 11.5 | 10.4 |
| | 2.5 | 3.1 | 7.2 | | | | | | 8.7 | 5.9 | 0.68 | 0.81 | 11.5 | 10.7 |
| 120 | 1.2 | 0.6 | 1.4 | | | | | | Operation not recommended | | | | | |
| | 1.8 | 1.7 | 4.0 | | | | | | 8.2 | 5.5 | 0.67 | 0.90 | 11.3 | 9.1 |
| | 2.5 | 3.0 | 6.9 | | | | | | 8.3 | 5.6 | 0.68 | 0.88 | 11.3 | 9.5 |

The manufacturer works continually to improve its products. As a result, the design and specifications of each product at the time of order may be changed without notice. Purchaser's approval of this data set signifies that the equipment is acceptable under the provisions of the job specification. Statements and other information contained herein are not express warranties and do not form the basis of any bargain between the parties, but are merely the manufacturer's opinion or commendation of its products.

Contractor: _____ P.O.: _____

Engineer: _____

Project Name: _____ Unit Tag: _____

Aston Series Console
0.75 - 1.5 Tons 60Hz



GC12 - Performance Data

350 Rated CFM Heating / Cooling

Performance capacities shown in thousands of Btuh.

| EWT °F | Flow Rate GPM | Water Pressure Drop | | HEATING - EAT 70 °F | | | | | COOLING - EAT 80/67 °F | | | | | |
|-----------|---------------------|------------------------|-------|---------------------------|-------------|-------------|-----------|------|---------------------------|-------------|--------------|-------------|-------------|------|
| | | PSI | FT/HD | HC kBtuh | Power kW | HE kBtuh | LAT °F | COP | TC kBtuh | SC kBtuh | S/T Ratio | Power kW | HR kBtuh | EER |
| | | | | | | | | | | | | | | |
| 20 | 1.5 | 1.0 | 2.3 | Operation not recommended | | | | | Operation not recommended | | | | | |
| | 2.3 | 1.7 | 4.0 | Operation not recommended | | | | | Operation not recommended | | | | | |
| | 3.5 | 3.2 | 7.4 | 8.6 | 0.80 | 5.9 | 90.8 | 3.15 | Operation not recommended | | | | | |
| 30 | 1.5 | 0.9 | 2.1 | Operation not recommended | | | | | Operation not recommended | | | | | |
| | 2.3 | 1.7 | 3.8 | 10.0 | 0.85 | 7.1 | 94.3 | 3.44 | 14.2 | 9.8 | 0.69 | 0.45 | 15.8 | 31.6 |
| | 3.5 | 3.0 | 6.9 | 10.2 | 0.86 | 7.3 | 95.1 | 3.48 | 14.4 | 10.0 | 0.69 | 0.42 | 15.9 | 34.1 |
| 40 | 1.5 | 0.9 | 2.0 | 10.8 | 0.88 | 7.8 | 96.7 | 3.62 | Operation not recommended | | | | | |
| | 2.3 | 1.6 | 3.7 | 11.0 | 0.88 | 8.0 | 97.0 | 3.66 | 13.7 | 9.5 | 0.70 | 0.54 | 15.5 | 25.5 |
| | 3.5 | 2.9 | 6.6 | 11.3 | 0.89 | 8.2 | 97.8 | 3.72 | 13.9 | 9.7 | 0.70 | 0.50 | 15.6 | 27.6 |
| 50 | 1.5 | 0.8 | 1.8 | 11.9 | 0.91 | 8.8 | 99.6 | 3.86 | 13.0 | 9.1 | 0.70 | 0.64 | 15.2 | 20.2 |
| | 2.3 | 1.5 | 3.5 | 12.1 | 0.91 | 9.0 | 100.0 | 3.89 | 13.1 | 9.2 | 0.71 | 0.62 | 15.2 | 21.1 |
| | 3.5 | 2.7 | 6.2 | 12.3 | 0.92 | 9.2 | 100.6 | 3.94 | 13.3 | 9.4 | 0.71 | 0.58 | 15.3 | 22.8 |
| 60 | 1.5 | 0.8 | 1.7 | 13.2 | 0.94 | 10.0 | 103.0 | 4.14 | 12.1 | 8.6 | 0.71 | 0.71 | 14.5 | 17.0 |
| | 2.3 | 1.4 | 3.3 | 13.4 | 0.94 | 10.2 | 103.4 | 4.16 | 12.2 | 8.7 | 0.71 | 0.68 | 14.5 | 17.8 |
| | 3.5 | 2.6 | 6.0 | 13.7 | 0.96 | 10.4 | 104.2 | 4.19 | 12.4 | 8.9 | 0.71 | 0.65 | 14.6 | 19.2 |
| 70 | 1.5 | 0.7 | 1.6 | 14.5 | 0.97 | 11.2 | 106.4 | 4.39 | 11.1 | 8.0 | 0.72 | 0.77 | 13.8 | 14.4 |
| | 2.3 | 1.4 | 3.2 | 14.7 | 0.98 | 11.4 | 106.9 | 4.40 | 11.3 | 8.1 | 0.72 | 0.75 | 13.8 | 15.0 |
| | 3.5 | 2.5 | 5.8 | 15.0 | 1.00 | 11.6 | 107.7 | 4.41 | 11.5 | 8.3 | 0.72 | 0.71 | 13.9 | 16.3 |
| 80 | 1.5 | 0.7 | 1.5 | 15.6 | 1.03 | 12.1 | 109.4 | 4.45 | 10.6 | 7.8 | 0.73 | 0.84 | 13.5 | 12.6 |
| | 2.3 | 1.3 | 3.0 | 15.9 | 1.04 | 12.3 | 110.0 | 4.48 | 10.9 | 7.9 | 0.73 | 0.80 | 13.6 | 13.5 |
| | 3.5 | 2.5 | 5.7 | 16.1 | 1.05 | 12.5 | 110.6 | 4.50 | 11.0 | 8.0 | 0.73 | 0.78 | 13.7 | 14.1 |
| 90 | 1.5 | 0.6 | 1.4 | 16.7 | 1.07 | 13.0 | 112.1 | 4.55 | 10.2 | 7.5 | 0.73 | 0.92 | 13.4 | 11.1 |
| | 2.3 | 1.3 | 2.9 | 16.9 | 1.09 | 13.2 | 112.8 | 4.56 | 10.4 | 7.6 | 0.74 | 0.88 | 13.4 | 11.8 |
| | 3.5 | 2.4 | 5.5 | 17.2 | 1.10 | 13.4 | 113.5 | 4.57 | 10.5 | 7.7 | 0.73 | 0.85 | 13.4 | 12.4 |
| 100 | 1.5 | 0.6 | 1.3 | Operation not recommended | | | | | Operation not recommended | | | | | |
| | 2.3 | 1.2 | 2.8 | | | | | | 9.7 | 7.3 | 0.75 | 1.00 | 13.1 | 9.7 |
| | 3.5 | 2.3 | 5.3 | | | | | | 9.8 | 7.4 | 0.75 | 0.97 | 13.1 | 10.1 |
| 110 | 1.5 | 0.5 | 1.2 | | | | | | Operation not recommended | | | | | |
| | 2.3 | 1.1 | 2.6 | | | | | | 8.9 | 6.9 | 0.77 | 1.11 | 12.7 | 8.1 |
| | 3.5 | 2.2 | 5.1 | | | | | | 9.1 | 7.0 | 0.77 | 1.08 | 12.8 | 8.4 |
| 120 | 1.5 | 0.5 | 1.2 | | | | | | Operation not recommended | | | | | |
| | 2.3 | 1.1 | 2.5 | | | | | | 8.5 | 6.7 | 0.79 | 1.21 | 12.6 | 7.0 |
| | 3.5 | 2.1 | 4.9 | | | | | | 8.7 | 6.8 | 0.78 | 1.18 | 12.7 | 7.4 |

The manufacturer works continually to improve its products. As a result, the design and specifications of each product at the time of order may be changed without notice. Purchaser's approval of this data set signifies that the equipment is acceptable under the provisions of the job specification. Statements and other information contained herein are not express warranties and do not form the basis of any bargain between the parties, but are merely the manufacturer's opinion or commendation of its products.

Contractor: _____ P.O.: _____

Engineer: _____

Project Name: _____ Unit Tag: _____

Aston Series Console
0.75 - 1.5 Tons 60Hz



GC15 - Performance Data

450 Rated CFM Heating / Cooling

Performance capacities shown in thousands of Btuh.

| EWT °F | Flow Rate GPM | Water Pressure Drop | | HEATING - EAT 70 °F | | | | | COOLING - EAT 80/67 °F | | | | | | | | | | | |
|-----------|---------------------|------------------------|-------|---------------------------|-------------|-------------|-----------|------|---------------------------|-------------|--------------|-------------|-------------|------|---------------------------|--|--|--|--|--|
| | | PSI | FT/HD | HC kBtuh | Power kW | HE kBtuh | LAT °F | COP | TC kBtuh | SC kBtuh | S/T Ratio | Power kW | HR kBtuh | EER | | | | | | |
| 20 | 2.0 | 1.8 | 4.1 | Operation not recommended | | | | | Operation not recommended | | | | | | | | | | | |
| | 3.0 | 3.4 | 7.8 | Operation not recommended | | | | | Operation not recommended | | | | | | | | | | | |
| | 4.5 | 5.9 | 13.6 | 10.7 | 0.93 | 7.5 | 90.0 | 3.37 | Operation not recommended | | | | | | | | | | | |
| 30 | 2.0 | 1.7 | 3.9 | Operation not recommended | | | | | Operation not recommended | | | | | | | | | | | |
| | 3.0 | 3.3 | 7.6 | 11.8 | 0.95 | 8.5 | 92.2 | 3.62 | 17.1 | 12.2 | 0.71 | 0.48 | 18.7 | 35.6 | | | | | | |
| | 4.5 | 5.7 | 13.2 | 12.3 | 0.97 | 9.0 | 93.3 | 3.72 | 17.3 | 12.4 | 0.71 | 0.45 | 18.9 | 38.4 | | | | | | |
| 40 | 2.0 | 1.7 | 3.8 | 12.7 | 0.95 | 9.4 | 94.1 | 3.93 | Operation not recommended | | | | | | | | | | | |
| | 3.0 | 3.2 | 7.5 | 12.9 | 0.96 | 9.6 | 94.6 | 3.94 | 16.7 | 12.0 | 0.72 | 0.60 | 18.8 | 27.8 | | | | | | |
| | 4.5 | 5.6 | 12.9 | 13.4 | 0.98 | 10.1 | 95.6 | 4.02 | 17.0 | 12.2 | 0.72 | 0.57 | 18.9 | 30.0 | | | | | | |
| 50 | 2.0 | 1.6 | 3.7 | 13.9 | 0.95 | 10.6 | 96.5 | 4.27 | 16.2 | 11.7 | 0.72 | 0.75 | 18.8 | 21.5 | | | | | | |
| | 3.0 | 3.2 | 7.3 | 14.1 | 0.97 | 10.8 | 97.1 | 4.28 | 16.4 | 11.8 | 0.72 | 0.72 | 18.8 | 22.6 | | | | | | |
| | 4.5 | 5.5 | 12.7 | 14.6 | 0.99 | 11.2 | 97.9 | 4.31 | 16.6 | 12.0 | 0.72 | 0.68 | 18.9 | 24.4 | | | | | | |
| 60 | 2.0 | 1.6 | 3.6 | 15.2 | 0.96 | 12.0 | 99.4 | 4.66 | 15.5 | 11.4 | 0.74 | 0.84 | 18.3 | 18.3 | | | | | | |
| | 3.0 | 3.1 | 7.1 | 15.6 | 0.97 | 12.2 | 100.0 | 4.69 | 15.6 | 11.5 | 0.74 | 0.81 | 18.4 | 19.2 | | | | | | |
| | 4.5 | 5.4 | 12.5 | 16.1 | 1.00 | 12.7 | 101.0 | 4.72 | 15.9 | 11.8 | 0.74 | 0.77 | 18.5 | 20.7 | | | | | | |
| 70 | 2.0 | 1.5 | 3.5 | 16.6 | 0.96 | 13.3 | 102.2 | 5.05 | 14.7 | 11.1 | 0.76 | 0.94 | 17.9 | 15.7 | | | | | | |
| | 3.0 | 3.0 | 7.0 | 17.0 | 0.98 | 13.7 | 103.0 | 5.08 | 14.9 | 11.3 | 0.76 | 0.90 | 18.0 | 16.5 | | | | | | |
| | 4.5 | 5.3 | 12.2 | 17.6 | 1.00 | 14.1 | 104.1 | 5.12 | 15.2 | 11.5 | 0.76 | 0.86 | 18.1 | 17.8 | | | | | | |
| 80 | 2.0 | 1.5 | 3.4 | 18.3 | 1.03 | 14.8 | 105.7 | 5.22 | 14.2 | 10.9 | 0.77 | 1.00 | 17.6 | 14.1 | | | | | | |
| | 3.0 | 3.0 | 6.8 | 18.6 | 1.04 | 15.1 | 106.3 | 5.24 | 14.5 | 11.1 | 0.77 | 0.96 | 17.7 | 15.1 | | | | | | |
| | 4.5 | 5.2 | 12.0 | 18.9 | 1.05 | 15.3 | 106.8 | 5.26 | 14.7 | 11.2 | 0.76 | 0.93 | 17.8 | 15.8 | | | | | | |
| 90 | 2.0 | 1.4 | 3.2 | 19.6 | 1.07 | 15.9 | 108.3 | 5.35 | 13.7 | 10.6 | 0.77 | 1.08 | 17.4 | 12.7 | | | | | | |
| | 3.0 | 2.9 | 6.7 | 19.9 | 1.09 | 16.2 | 108.9 | 5.36 | 13.9 | 10.8 | 0.78 | 1.03 | 17.4 | 13.5 | | | | | | |
| | 4.5 | 5.1 | 11.8 | 20.2 | 1.10 | 16.4 | 109.5 | 5.38 | 14.1 | 10.9 | 0.77 | 1.00 | 17.5 | 14.1 | | | | | | |
| 100 | 2.0 | 1.4 | 3.1 | Operation not recommended | | | | | Operation not recommended | | | | | | | | | | | |
| | 3.0 | 2.8 | 6.5 | | | | | | 13.4 | 10.5 | 0.78 | 1.14 | 17.3 | 11.8 | | | | | | |
| | 4.5 | 5.0 | 11.6 | | | | | | 13.6 | 10.6 | 0.78 | 1.10 | 17.3 | 12.3 | | | | | | |
| 110 | 2.0 | 1.3 | 3.0 | | | | | | Operation not recommended | | | | | | Operation not recommended | | | | | |
| | 3.0 | 2.8 | 6.4 | | | | | | 12.8 | 10.1 | 0.79 | 1.23 | 17.0 | 10.4 | | | | | | |
| | 4.5 | 4.9 | 11.3 | | | | | | 13.0 | 10.3 | 0.79 | 1.20 | 17.1 | 10.8 | | | | | | |
| 120 | 2.0 | 1.3 | 2.9 | | | | | | Operation not recommended | | | | | | Operation not recommended | | | | | |
| | 3.0 | 2.7 | 6.2 | | | | | | 11.3 | 9.2 | 0.81 | 1.39 | 16.0 | 8.1 | | | | | | |
| | 4.5 | 4.8 | 11.1 | | | | | | 11.5 | 9.3 | 0.81 | 1.35 | 16.1 | 8.5 | | | | | | |

The manufacturer works continually to improve its products. As a result, the design and specifications of each product at the time of order may be changed without notice. Purchaser's approval of this data set signifies that the equipment is acceptable under the provisions of the job specification. Statements and other information contained herein are not express warranties and do not form the basis of any bargain between the parties, but are merely the manufacturer's opinion or commendation of its products.

Contractor: _____ P.O.: _____

Engineer: _____

Project Name: _____ Unit Tag: _____

Aston Series Console
0.75 - 1.5 Tons 60Hz



GC18 - Performance Data

500 Rated CFM Heating / Cooling

Performance capacities shown in thousands of Btuh.

| EWT °F | Flow Rate GPM | Water Pressure Drop | | HEATING - EAT 70 °F | | | | | COOLING - EAT 80/67 °F | | | | | |
|-----------|---------------------|------------------------|-------|---------------------------|-------------|-------------|-----------|------|---------------------------|-------------|--------------|-------------|-------------|------|
| | | PSI | FT/HD | HC kBtuh | Power kW | HE kBtuh | LAT °F | COP | TC kBtuh | SC kBtuh | S/T Ratio | Power kW | HR kBtuh | EER |
| 20 | 3.0 | 1.8 | 4.1 | Operation not recommended | | | | | Operation not recommended | | | | | |
| | 4.0 | 4.2 | 9.7 | | | | | | | | | | | |
| | 5.5 | 8.0 | 18.5 | 13.0 | 1.20 | 8.9 | 92.0 | 3.16 | | | | | | |
| 30 | 3.0 | 1.7 | 3.9 | Operation not recommended | | | | | Operation not recommended | | | | | |
| | 4.0 | 4.1 | 9.6 | 14.2 | 1.24 | 10.0 | 94.3 | 3.35 | 22.2 | 16.0 | 0.72 | 0.69 | 24.6 | 32.1 |
| | 5.5 | 7.9 | 18.2 | 14.3 | 1.25 | 10.1 | 94.5 | 3.36 | 22.5 | 16.3 | 0.72 | 0.65 | 24.7 | 34.6 |
| 40 | 3.0 | 1.7 | 3.8 | 15.5 | 1.26 | 11.2 | 96.7 | 3.60 | Operation not recommended | | | | | |
| | 4.0 | 4.1 | 9.4 | 15.8 | 1.27 | 11.5 | 97.3 | 3.65 | 21.3 | 15.5 | 0.72 | 0.79 | 24.1 | 26.9 |
| | 5.5 | 7.8 | 17.9 | 16.2 | 1.28 | 11.8 | 98.0 | 3.71 | 21.7 | 15.8 | 0.73 | 0.75 | 24.2 | 29.1 |
| 50 | 3.0 | 1.6 | 3.7 | 17.2 | 1.28 | 12.8 | 99.9 | 3.93 | 20.3 | 14.8 | 0.73 | 0.93 | 23.5 | 21.9 |
| | 4.0 | 4.0 | 9.2 | 17.6 | 1.29 | 13.2 | 100.5 | 3.98 | 20.5 | 14.9 | 0.73 | 0.89 | 23.5 | 23.0 |
| | 5.5 | 7.6 | 17.6 | 18.1 | 1.31 | 13.6 | 101.5 | 4.05 | 20.8 | 15.2 | 0.73 | 0.84 | 23.7 | 24.8 |
| 60 | 3.0 | 1.6 | 3.6 | 19.2 | 1.30 | 14.8 | 103.6 | 4.33 | 19.0 | 13.9 | 0.73 | 1.01 | 22.4 | 18.7 |
| | 4.0 | 3.9 | 9.1 | 19.7 | 1.32 | 15.2 | 104.4 | 4.37 | 19.2 | 14.1 | 0.73 | 0.97 | 22.5 | 19.7 |
| | 5.5 | 7.5 | 17.3 | 20.3 | 1.34 | 15.7 | 105.6 | 4.43 | 19.5 | 14.4 | 0.74 | 0.92 | 22.6 | 21.2 |
| 70 | 3.0 | 1.5 | 3.5 | 21.3 | 1.32 | 16.8 | 107.4 | 4.71 | 17.6 | 13.1 | 0.74 | 1.09 | 21.3 | 16.1 |
| | 4.0 | 3.9 | 8.9 | 21.8 | 1.34 | 17.2 | 108.3 | 4.75 | 17.8 | 13.2 | 0.74 | 1.06 | 21.5 | 16.9 |
| | 5.5 | 7.4 | 17.1 | 22.5 | 1.37 | 17.8 | 109.7 | 4.80 | 18.2 | 13.5 | 0.74 | 1.00 | 21.6 | 18.2 |
| 80 | 3.0 | 1.5 | 3.4 | 23.3 | 1.40 | 18.6 | 111.2 | 4.88 | 17.1 | 12.9 | 0.75 | 1.25 | 21.3 | 13.7 |
| | 4.0 | 3.8 | 8.8 | 23.7 | 1.41 | 18.9 | 111.9 | 4.92 | 17.4 | 13.1 | 0.75 | 1.19 | 21.5 | 14.7 |
| | 5.5 | 7.3 | 16.9 | 24.0 | 1.43 | 19.1 | 112.4 | 4.93 | 17.7 | 13.2 | 0.75 | 1.15 | 21.6 | 15.3 |
| 90 | 3.0 | 1.4 | 3.2 | 24.7 | 1.44 | 19.8 | 113.8 | 5.03 | 16.6 | 12.6 | 0.76 | 1.41 | 21.4 | 11.8 |
| | 4.0 | 3.7 | 8.6 | 25.1 | 1.46 | 20.1 | 114.5 | 5.04 | 16.9 | 12.8 | 0.76 | 1.34 | 21.5 | 12.6 |
| | 5.5 | 7.2 | 16.6 | 25.5 | 1.48 | 20.5 | 115.2 | 5.06 | 17.1 | 12.9 | 0.75 | 1.30 | 21.5 | 13.2 |
| 100 | 3.0 | 1.4 | 3.1 | Operation not recommended | | | | | Operation not recommended | | | | | |
| | 4.0 | 3.7 | 8.5 | | | | | | 16.4 | 12.5 | 0.76 | 1.49 | 21.5 | 11.0 |
| | 5.5 | 7.1 | 16.3 | | | | | | 16.6 | 12.6 | 0.76 | 1.44 | 21.5 | 11.5 |
| 110 | 3.0 | 1.3 | 3.0 | | | | | | Operation not recommended | | | | | |
| | 4.0 | 3.6 | 8.3 | | | | | | 15.8 | 12.1 | 0.77 | 1.62 | 21.3 | 9.7 |
| | 5.5 | 6.9 | 15.9 | | | | | | 16.0 | 12.3 | 0.77 | 1.58 | 21.4 | 10.1 |
| 120 | 3.0 | 1.3 | 2.9 | | | | | | Operation not recommended | | | | | |
| | 4.0 | 3.5 | 8.2 | | | | | | 14.7 | 11.7 | 0.80 | 1.77 | 20.8 | 8.3 |
| | 5.5 | 6.8 | 15.7 | | | | | | 15.0 | 11.9 | 0.79 | 1.72 | 20.9 | 8.7 |

The manufacturer works continually to improve its products. As a result, the design and specifications of each product at the time of order may be changed without notice. Purchaser's approval of this data set signifies that the equipment is acceptable under the provisions of the job specification. Statements and other information contained herein are not express warranties and do not form the basis of any bargain between the parties, but are merely the manufacturer's opinion or commendation of its products.

Contractor: _____ P.O.: _____

Engineer: _____

Project Name: _____ Unit Tag: _____

Aston Series Console
0.75 - 1.5 Tons 60Hz



Wiring Schematics

CCM - ELECTRONIC THERMOSTAT

208-230-265/60/1

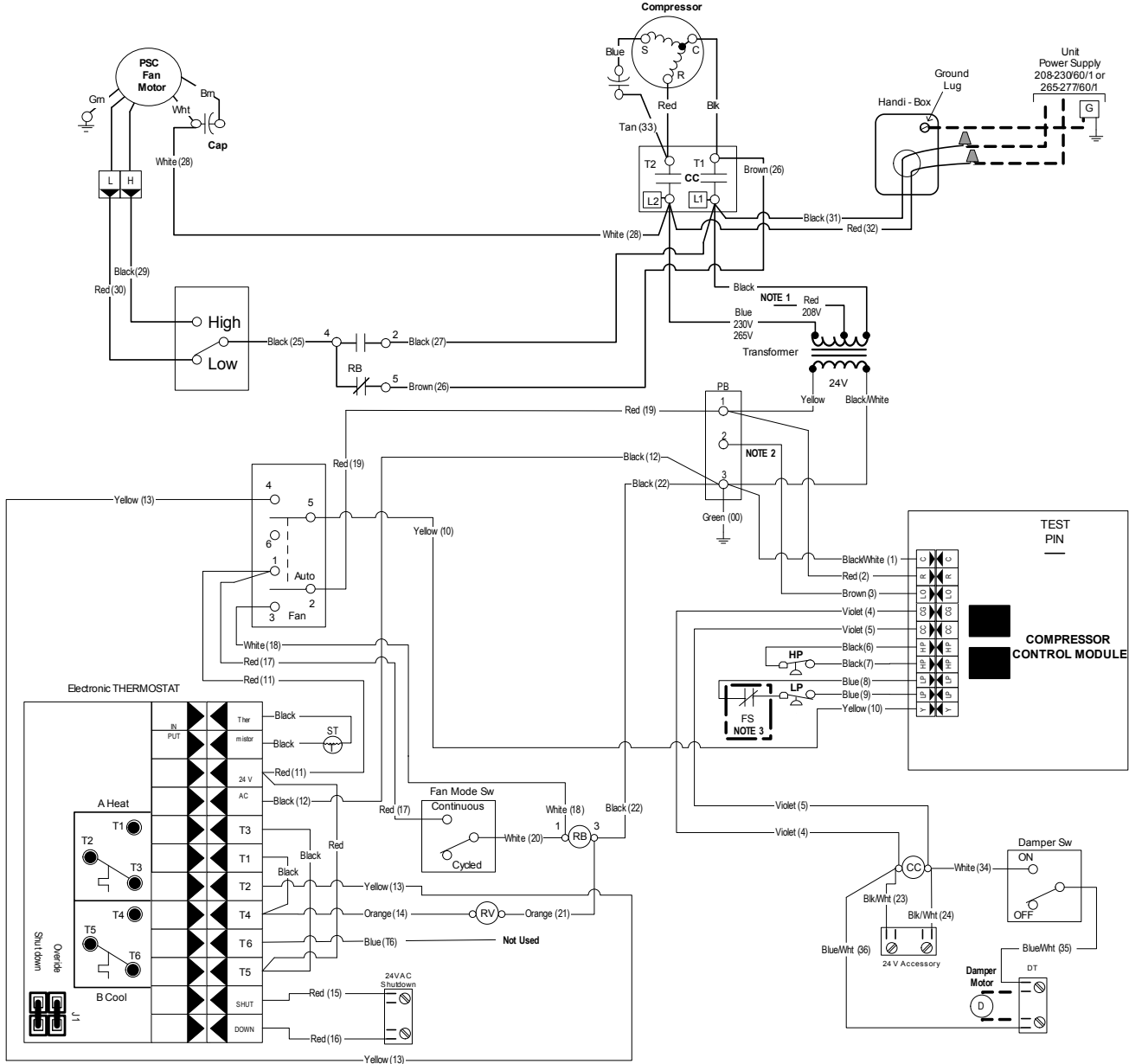

| Legend | | | |
|-----------------------------|--------------------------------------|-----------------------------|------------------------|
| Factory low voltage wiring | CC - Compressor Contactor | Field wire lug | Switch - High Pressure |
| Factory line voltage wiring | DT - Damper Terminal Block | Earth Ground | Switch - Low Pressure |
| Field low voltage wiring | FS - Freeze Sensing Device | Relay Contacts - N.O., N.C. | Relay coil |
| Field line voltage wiring | HP - High Pressure Switch | Polarized connector | Capacitor |
| Quick connect terminal | LP - Low Pressure Switch | | Thermistor |
| Wire nut | PB - Power Block | | Temperature Switch |
| | RB - Blower Relay | | |
| | RV - Reversing Valve Coil | | |
| | ST - Entering Air Temperature Sensor | | |

Notes:
 1. Switch Red and Blue wires for 208 volt operation
 2. Terminal C of 24 V PB is used as "L" output for Brown wire3 for Lockout
 3. Optional field installed freeze sensing device.

6/10/08

The manufacturer works continually to improve its products. As a result, the design and specifications of each product at the time of order may be changed without notice. Purchaser's approval of this data set signifies that the equipment is acceptable under the provisions of the job specification. Statements and other information contained herein are not express warranties and do not form the basis of any bargain between the parties, but are merely the manufacturer's opinion or commendation of its products.

Contractor: _____ P.O.: _____

Engineer: _____

Project Name: _____ Unit Tag: _____



208-230-265/60/1

Wiring Schematics cont.

VERSATEC CONTROL - EH & REMOTE WALL THERMOSTAT

Legend for Schematic [A]

Normal Control Timing Table

| | |
|---|--|
| Blower off delay | 30 seconds |
| Compressor on delay | 10 seconds |
| Short cycle delay | 5 minutes |
| Minimum compressor on time | 60 seconds (except for fault condition) |
| High pressure fault recognition delay | Less than 1 second |
| Low pressure fault recognition delay | 30 seconds |
| Freeze sensing fault recognition delay | 30 seconds |
| Condensate overflow fault recognition delay | 30 seconds |
| Low pressure fault bypass delay | 2 minutes |
| Freeze sensing fault bypass delay | 2 minutes |
| Motorized valve delay | 90 seconds |
| Random start delay | 0 - 25 seconds |

Test Control Timing Table

| | |
|---|---|
| Blower off delay | 5 seconds |
| Compressor on delay | 2 seconds |
| Short cycle delay | 15 seconds |
| Minimum compressor on time | 5 seconds (except for fault condition) |
| High pressure fault recognition delay | Less than 1 second |
| Low pressure fault recognition delay | 30 seconds |
| Freeze sensing fault recognition delay | 30 seconds |
| Condensate overflow fault recognition delay | 30 seconds |
| Low pressure fault bypass delay | 0 seconds |
| Freeze sensing fault bypass delay | 0 seconds |
| Motorized valve delay | 90 seconds |
| Random start delay | 0 seconds |

LED Display Mode Table

| LED | Normal Display Mode |
|------------|--|
| | SW1 - #4 On, SW2 Off |
| Drain | Drain pan overflow lockout |
| Water Flow | FS thermistor (loop <15°F, well <30°F) lockout |
| High Press | High pressure >600 PSI lockout |
| Low Press | Low pressure <40 PSI lockout |
| Air Flow | Not used |
| Status | Microprocessor malfunction* |
| DHW Limit | Not Used |
| HWD | SW2 status (Off = down position, On = up position) |

Diagnostic Modes

| LED | Current Fault Status | Inputs | Outputs |
|------------|--|-----------------------|----------------------|
| | SW1 - #4 On, SW2 On | SW1 - #4 Off, SW2 Off | SW1 - #4 Off, SW2 On |
| Drain | Drain pan overflow | Y | Compressor |
| Water Flow | FS thermistor (loop <15°F, well <30°F) | G | FAN |
| High Press | High pressure >600 PSI | O | O |
| Low Press | Low pressure <40 PSI | ES | ES |
| Air Flow | Not used | NS | NS |
| Status | Not used | LS | LS |
| DHW Limit | Not used | Not Used | Not Used |
| HWD | SW2 in the On position | Off position | On position |

*Flashing Status light indicates microprocessor is functioning properly. Solid "on" indicates a microprocessor malfunction.

Versatec Logic Board Physical Layout

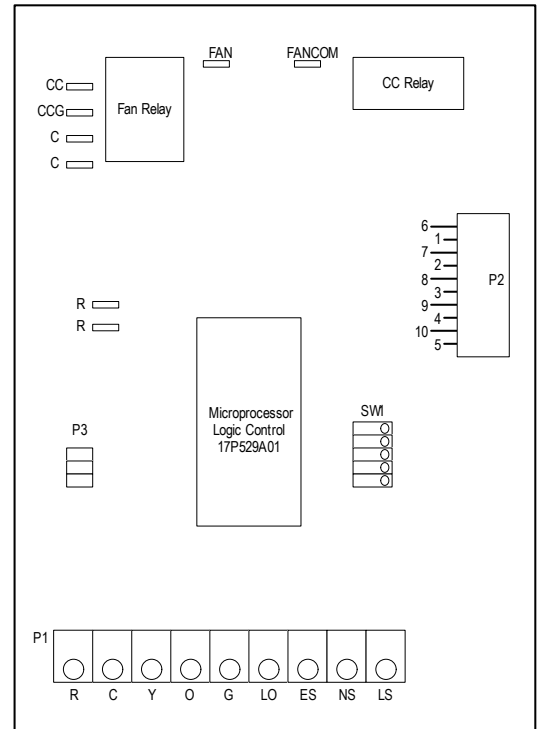

Logic Board DIP Switch Settings

| Switch | OFF | ON |
|---------|--|---|
| SW1 - 1 | Test - Selected timings sped up to facilitate troubleshooting | Normal - Standard timings |
| SW1 - 2 | Loop - Closed loop freeze sensing setting (15°F) | Well - Open loop freeze sensing setting (30°F) |
| SW1 - 3 | Enables NS features | Normal - Standard thermostat operation |
| SW1 - 4 | ID Display * - Enables Input/Output display on external LED board* | Normal * - Unit status display |
| SW1 - 5 | Motorized Valve - 1.5 minute compressor on delay | Normal - Standard delay on call from compressor used |
| SW2 | OFF * - Normal or Input display mode activated | ON * - Current fault or Output display mode activated |

*Refer to LED Display Mode table for position of SW1-4 and SW2

Operational Logic Table

| Mode | Inputs | Fan | Comp | RV |
|------|--------|-----|------|-----|
| Htg | Y | ON | ON | OFF |
| Clg | Y,O | ON | ON | ON |
| Fan | G | ON | OFF | OFF |

The manufacturer works continually to improve its products. As a result, the design and specifications of each product at the time of order may be changed without notice. Purchaser's approval of this data set signifies that the equipment is acceptable under the provisions of the job specification. Statements and other information contained herein are not express warranties and do not form the basis of any bargain between the parties, but are merely the manufacturer's opinion or commendation of its products.

Contractor: _____ P.O.: _____

Engineer: _____

Project Name: _____ Unit Tag: _____

Aston Series Console
0.75 - 1.5 Tons 60Hz



Wiring Schematics cont.

VERSATEC CONTROL - EH & REMOTE WALL THERMOSTAT

208-230-265/60/1

Schematic [A]

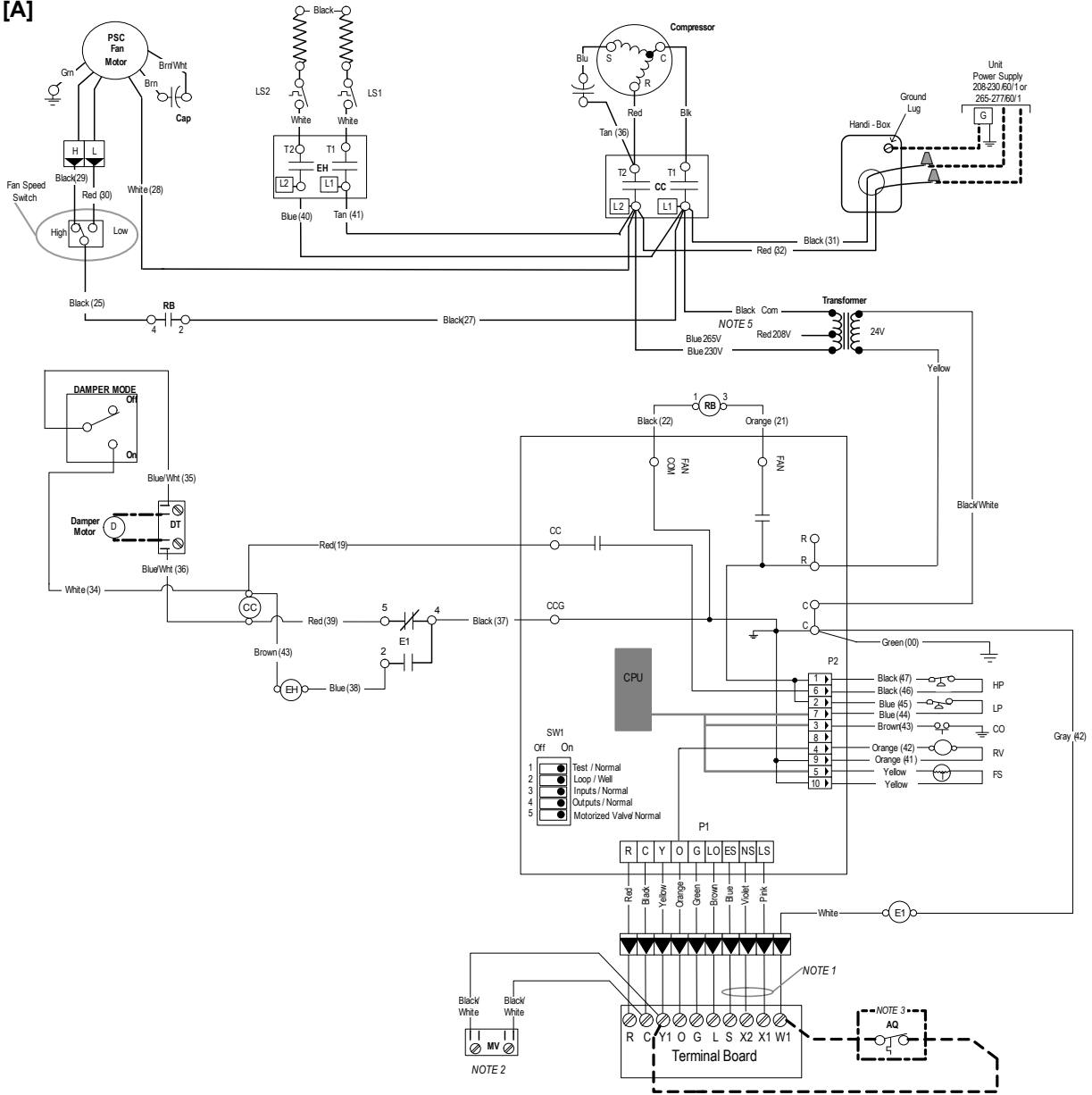

| Legend | | | | |
|--------|--|--|--|--|
| | | | | |
| | | | | |
| | | | | |
| | | | | |
| | | | | |
| | | | | |

- Notes**
- 1- Requires common connection or 24 VAC for activation.
 - 2- When field installed 24VAC motorized valve is used connect to C and Y or SV terminals
 - 3- Optional field installed aquastat for use with single heat
 - 4- Check installation wiring information for specific thermostat hookup instructions
 - 5- Switch blue and red wires for 208V operation.

6/10/08

The manufacturer works continually to improve its products. As a result, the design and specifications of each product at the time of order may be changed without notice. Purchaser's approval of this data set signifies that the equipment is acceptable under the provisions of the job specification. Statements and other information contained herein are not express warranties and do not form the basis of any bargain between the parties, but are merely the manufacturer's opinion or commendation of its products.

Contractor: _____ P.O.: _____

Engineer: _____

Project Name: _____ Unit Tag: _____

Aston Series Console
0.75 - 1.5 Tons 60Hz



Wiring Schematics cont.

FX10 - EH

208-230-265/60/1

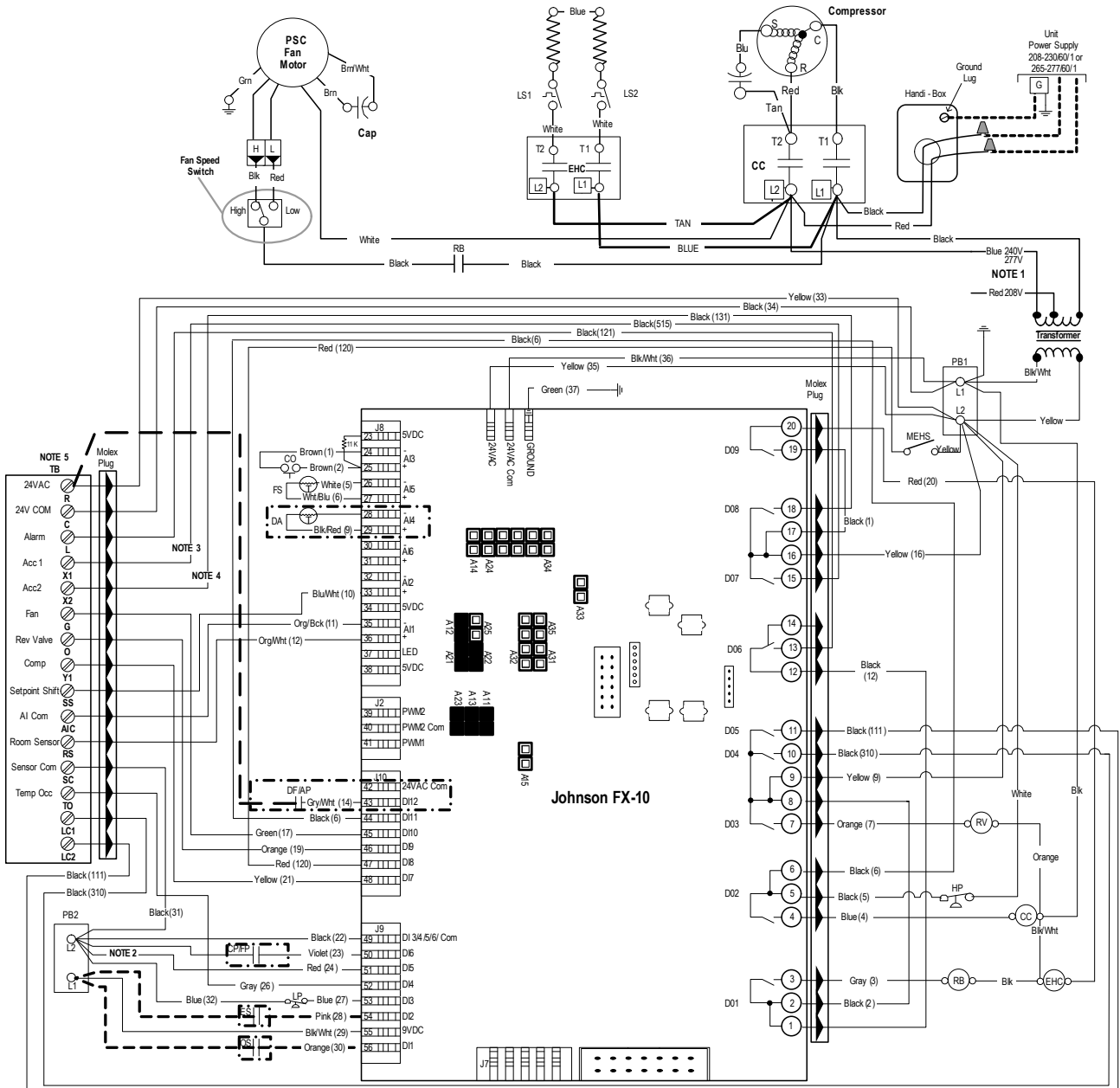

| Legend | | | |
|--------|----------------------------|--|---------------------------------|
| | Factory low voltage wiring | | Relay Contacts N.O., N.C. |
| | Factory low voltage wiring | | Thermistor - Johnson Control |
| | Field line voltage wiring | | Relay coil |
| | Field Zone Sensor Wiring | | Open Jumper |
| | Internal junction | | Closed Jumper |
| | Quick connect terminal | | Switch - High pressure |
| | Wire nut | | Switch - Low pressure |
| | Field wire lug | | Polarized connector |
| | Ground | | Condensate Overflow |
| | | | CC - Compressor Contactor |
| | | | CO - Condensate Overflow |
| | | | CPFP - Compressor Protection |
| | | | DA - Discharge Air Temperature |
| | | | DFAP - Dirty Filter Air Proving |
| | | | EHC - Electric Heat Contactor |
| | | | EHR - Electric Heat Relay |
| | | | ES - Emergency Shutdown |
| | | | FS - Freeze Sensing Device |
| | | | HP - High Pressure Switch |
| | | | LP - Low Pressure Switch |
| | | | MEHS - Manual EH Switch |
| | | | OS - Occupied Switch |
| | | | RB - Blower Power Relay |
| | | | RV - Reversing Valve Coil |
| | | | TB - Terminal Block |

- Notes:**
- 1 - Switch Blue and Red wires for 208V operation
 - 2 - Disconnect for 15 degree freeze protection
 - 3 - Acc 1 output is cycled with the compressor
 - 4 - Acc 2 output is cycled with the fan
 - 5 - R, C, Y1, O, and G inputs are for use with a wall mounted thermostat

6/10/08

The manufacturer works continually to improve its products. As a result, the design and specifications of each product at the time of order may be changed without notice. Purchaser's approval of this data set signifies that the equipment is acceptable under the provisions of the job specification. Statements and other information contained herein are not express warranties and do not form the basis of any bargain between the parties, but are merely the manufacturer's opinion or commendation of its products.

Contractor: _____ P.O.: _____

Engineer: _____

Project Name: _____ Unit Tag: _____



Engineering Guide Specifications

General

Furnish and install Water Source Heat Pumps, as indicated on the plans. Equipment shall be completely assembled, piped and internally wired. Chassis shall be installed with factory built cabinet or other approved custom cabinet. Chassis SHALL NOT be installed without an approved cabinet enclosure. Capacities and characteristics as listed in the schedule and the specifications that follow. The reverse cycle heating/cooling units shall be floor mounted console type with horizontal air inlet and up-flow air discharge. Units shall be AHRI/ISO 13256-1 certified and listed by a nationally recognized safety-testing laboratory or agency, such as ETL Testing Laboratory. Each unit shall be computer run-tested at the factory with conditioned water and operation verified to catalog data. Each unit shall be mounted on a pallet and shipped in a corrugated box or stretch-wrapped. The units shall be designed to operate with entering liquid temperature between 20°F and 120°F [-6.7°C and 48.9°C].

Chassis & Cabinet

The cabinet shall be fabricated from heavy-gauge galvanized steel and finished with a beige textured epoxy powder coating on both sides for added protection. This corrosion protection system shall meet the stringent 1000 hour salt spray test per ASTM B117.

The cabinet shall be easily removable to allow for ease of service to the controls compartment, chassis, and piping. The top of the cabinet and grille is a horizontally flat (optional sloped) surface with a hinged control door cover. The return air filter shall be 1" (25.4 mm) fiberglass disposable type media.

The return and supply air sections are insulated with a 1/4" (6.4 mm) thick, dual density, 2 lb/ft³ (32 kg/m³) coated mat glass fiber with edges sealed or tucked under flanges to prevent the introduction of glass fibers into the discharge supply air through the aluminum grille. Standard cabinet panel insulation must meet NFPA 90A requirements, air erosion and mold growth limits of UL-181, stringent fungal resistance test per ASTM-C1071 and ASTM G21, and shall meet zero level bacteria growth per ASTM G22. Unit insulation must meet these stringent requirements or unit(s) will not be accepted.

Option: A Super Quiet Sound package shall include multi-density full coverage compressor blanket.

Option: Shipped with motorized outside air damper and damper assembly for 25% make-up air.

The drain pan shall be of stainless steel construction to inhibit corrosion and bacterial growth. Drain outlet shall be located on pan as to allow complete and unobstructed drainage of condensate. The unit as standard will be supplied with solid-state electronic condensate overflow protection with microprocessor or FX10 option. Mechanical float switches WILL NOT be accepted. Condensate tube shall be constructed of stainless steel and have an internal factory installed condensate trap.

Refrigerant Circuit

All units shall utilize the non-ozone depleting and low global warming potential refrigerant R410A. All units shall contain a sealed refrigerant circuit including a hermetic motor-compressor, bi-directional thermostatic expansion valve, finned tube air-to-refrigerant heat exchanger, reversing valve, coaxial tube water-to-refrigerant heat exchanger, and service ports.

Compressors shall be high-efficiency single speed rotary type designed for heat pump duty and mounted on durometer grommets to provide vibration free compressor mounting. Compressor motors shall be single-phase PSC with external overload protection.

The air coil shall be sized for low-face velocity and constructed of lanced aluminum fins bonded to rifled copper tubes in a staggered pattern not less than three rows deep for enhanced performance.

Option: FormiShield™ air coil coating for maximum protection against formicary corrosion.

The coaxial water-to-refrigerant heat exchanger shall be designed for low water pressure drop and constructed of a convoluted copper (cupronickel option) inner tube and a steel outer tube. Refrigerant to air heat exchangers shall utilize enhanced corrugated lanced aluminum fins and rifled copper tube construction rated to withstand 600 PSIG (4135 kPa) refrigerant working pressure. Refrigerant to water heat exchangers shall be of copper inner water tube and steel refrigerant outer tube design, rated to withstand 600 PSIG (4135 kPa) working refrigerant pressure and 450 PSIG (3101 kPa) working water pressure. The thermostatic expansion valve shall provide proper superheat over the entire liquid temperature range with minimal "hunting." The valve shall operate bi-directionally without the use of check valves.

Option: Cupro-nickel refrigerant to water heat exchanger shall be of copper-nickel inner water tube and steel refrigerant outer tube design, rated to withstand 600 PSIG (4135 kPa) working refrigerant pressure and 450 PSIG (3101 kPa) working water pressure. Water lines shall also be of cupronickel construction.

Option: ThermaShield coated water-to-refrigerant heat exchanger, water lines and refrigerant suction lines shall be insulated to prevent condensation at low liquid temperatures below 50°F.

Blower Motor & Assembly

The blower shall be a direct drive centrifugal type with a twin dynamically balanced wheel. The housing and wheel shall be designed for quiet, low outlet velocity operation. The blower housing shall be constructed of galvanized steel and shall be removable from the unit for servicing of the blower motor. The blower motor shall be a two-speed type and shall be isolated from the housing by rubber grommets. The motor shall be permanently lubricated and have thermal overload protection.

Contractor: _____ P.O.: _____

Engineer: _____

Project Name: _____ Unit Tag: _____



Engineering Guide Specifications cont.

Electrical

A control box shall be located within the unit compressor compartment and shall contain a 75VA transformer, 24 Volt activated, 2 pole compressor contactor, and solid-state controller for complete unit operation. Units shall be name-plated for use with time delay fuses or HACR circuit breakers. Unit controls shall be 24 Volt and provide heating or cooling as required by the remote thermostat/sensor.

Unit mounted controls shall consist of switches for "OFF", "FAN", and "AUTO" or "HEAT/COOL". An additional switch is provided for blower speed setting of "HI" or "LO". The unit shall be equipped with a blower switch on the side of the control to provide "CONTINUOUS" or "CYCLED" blower operation. "CYCLED" blower will turn the blower on with the compressor. A unit-mounted electronic thermostat with a remote electronic thermistor located in the return air will control compressor operation in heating and cooling modes. Unit mounted thermostat shall be the standard thermostat option. All unit mounted thermostats shall be auto changeover. Manual changeover WILL NOT be accepted. Electromechanical operation WILL NOT be accepted.

Controls

Standard: A compressor control module (CCM) shall be included to disable compressor operation in the event of a trip of any of the safety switches and to send a signal to activate a fault indicator light at the thermostat. The CCM shall be capable of being reset from the thermostat or from the unit main disconnect switch. A terminal block with screw terminals shall be provided for field connection of all low-voltage wiring.

Option: Versatec microprocessor-based controller will provide operational sequencing; high and low pressure switch monitoring, freeze detection, lockout mode control, emergency shutdown mode, random start, short cycle protection, LED mode and fault indicators, fault memory, input and output diagnostics, and field selectable options, and condensate overflow sensing.

Option: FX10 microprocessor-based controller that interfaces with an electronic thermostat to monitor and control unit operation. The control shall provide operational sequencing, blower speed control, high, low and loss of charge pressure monitoring, freeze detection, condensate overflow sensing, lockout mode control, fault memory, field selectable options. The control shall communicate all mode, status, fault and lockout codes to the front end system for fast and accurate equipment diagnosis. The control shall provide fault retry three times before locking out to limit nuisance trips.

Optional FX10 microprocessor control communication protocols: N2, LonWorks, or BACnet

Option: Remote mounted thermostat is available for CCM & Versatec (standard with FX10 option). A terminal block with screw terminals will be provided for field control wiring.

Piping

Supply and return water connections shall be 1/2 in. [12.7 mm] FPT copper threaded fittings. All water piping shall be insulated to prevent condensation at low liquid temperatures.

A stainless steel tube stubbed out from the chassis is provided for condensate drain attachment. A short piece of polyvinyl hose is supplied to assist in adapting to drain.

Accessories

Hose Kits – Ball Valves (field-installed)

A flexible steel braid hose featuring Kevlar® reinforced EPDM core with ANSI 302/304 stainless steel outer braid and fire rated materials per ASTM E 84-00 (NFPA 255, ANSI/UL 723 & UBC 8-1). Ball valve at one end; swivel connector with adapter at the other end (swivel to adapter connection via fiber or EPDM gasket). Swivel connection provides union between heat pump and piping system. The hoses feature brass fittings, stainless steel ferrules. A full port ball valve shall be provided with integral P/T (pressure/temperature) port on supply hose. Specifications: Temperature range of 35°F [2°C] to 180°F [82°C]. Max. working pressure of 400 psi [2757 kPa] for 1/2" and 3/4" hose kits; max. working pressure of 350 psi [kPa] for 1" and 1-1/4" hose kits.

Hose Kits - Automatic Balancing and Ball Valves (field-installed)

A flexible steel braid hose featuring Kevlar® reinforced EPDM core with ANSI 302/304 stainless steel outer braid and fire rated materials per ASTM E 84-00 (NFPA 255, ANSI/UL 723 & UBC 8-1). Ball valve at one end; swivel connector with adapter at the other end (swivel to adapter connection via fiber or EPDM gasket). Swivel connection provides union between heat pump and piping system. The hoses feature brass fittings, stainless steel ferrules. A full port ball valve shall be provided with integral P/T (pressure/temperature) port on supply hose and automatic balancing valve with integral P/T ports and full port ball valve on return hose. Specifications:

- Temperature range of 35°F [2°C] to 180°F [82°C].
- Max. working pressure of 400 psi [2757 kPa] for 1/2" and 3/4" hose kits; max. working pressure of 350 psi [2413 kPa] for 1" and 1-1/4" hose kits.
- Minimum burst pressure of four times working pressure.

Hose Kits – Automatic Balancing and Ball Valves with 'Y' strainer (field-installed)

A flexible steel braid hose featuring Kevlar® reinforced EPDM core with ANSI 302/304 stainless steel outer braid and fire rated materials per ASTM E 84-00 (NFPA 255, ANSI/UL 723 & UBC 8-1). Ball valve at one end; swivel connector with adapter at the other end (swivel to adapter connection via fiber or EPDM gasket). Swivel connection provides union between heat pump and piping system. The hoses feature brass fittings, stainless steel ferrules. A "y" strainer is provided on one end for fluid straining and integral "blowdown" valve.. A full port ball valve shall be provided with

Contractor: _____ P.O.: _____

Engineer: _____

Project Name: _____ Unit Tag: _____



Engineering Guide Specifications cont.

integral P/T (pressure/temperature) port on supply hose and automatic balancing valve with integral P/T ports and full port ball valve on return hose.

Specifications:

- Temperature range of 35°F [2°C] to 180°F [82°C].
- Max. working pressure of 400 psi [2757 kPa] for 1/2" and 3/4" hose kits; max. working pressure of 350 psi [2413 kPa] for 1" and 1-1/4" hose kits.
- Minimum burst pressure of four times working pressure.

Auxiliary Heater (field-installed 208-230V units only)

An electric resistance heater shall provide supplemental and/or emergency heating capability. A manual switch shall be mounted on the side of the control compartment with "NORMAL" or "BOILERLESS" mode. "NORMAL" will run the compressor when there is a call for heating or cooling. "BOILERLESS" mode operation will run electric heat whenever there is a call for heating and run the compressor for a cooling call.