

ASTON SERIES GXW CHILLER

COMMERCIAL UNITS



GEOSTAR
AFFORDABLE RENEWABLE CLEAN

Table of Contents

Nomenclature	4
AHRI Data	5-6
The GXW Series.	7-8
Inside the GXW Series	9-11
Controls	12-15
GXW Application Notes	16-17
Water Quality	17
Selection Process.	18
Typical Piping	18-19
Physical Dimensions	20-21
Vibration Isolators.	22
Physical Data	23
Electrical Data	24
Antifreeze Correction	25
Reference Calculations	26
Legend and Notes	26
Pressure Drop	27
Performance Data	28-37
Wiring Schematics	38-39
Engineering Guide Specifications.	40-43
Revision Guide.	45

Model Nomenclature

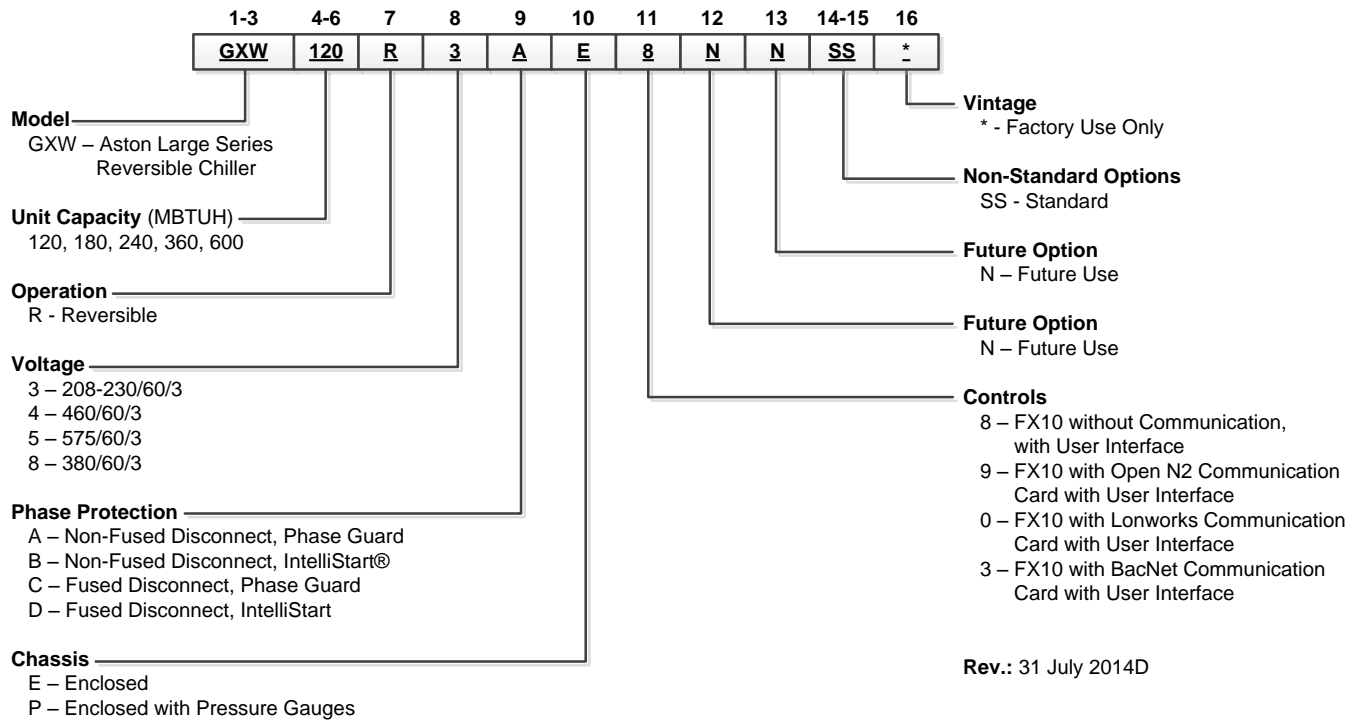

Notes:
See electrical availability table for detailed offering by voltage

Voltage Availability

Voltage	Model				
	120	180	240	360	600
208-230/60/3	●	●	●	●	N/A
460/60/3	●●	●●	●●	●	●
575/60/3	●	●	●	●	●

08/14/14

Legend:
 NA = Not Available
 ● = Voltage available in this size
 ●● = Voltage and IntelliStart available in this size



All GXW Series product is Safety listed under UL1995 thru ETL and performance tested in accordance with standard AHRI/ISO 13256-2.

AHRI/ASHRAE/ISO 13256-2 Water-to-Water Ratings

English (IP) Units

Model	Capacity Modulation	Flow Rate		Water Loop Heat Pump				Ground Water Heat Pump				Ground Loop Heat Pump			
				Cooling EST 86°F ELT 53.6°F		Heating EST 68°F ELT 104°F		Cooling EST 59°F ELT 53.6°F		Heating EST 50°F ELT 104°F		Cooling Full EST 77°F Part EST 68°F ELT 53.6°F		Heating Full EST 32°F Part ELT 41°F ELT 104°F	
		Sgpm	Lgpm	Capacity Btuh	EER Btuh/W	Capacity Btuh	COP	Capacity Btuh	EER Btuh/W	Capacity Btuh	COP	Capacity Btuh	EER Btuh/W	Capacity Btuh	COP
120	Full	40	40	145,400	16.0	189,000	4.5	161,400	22.5	157,200	3.8	147,700	17.3	118,800	3.0
	Part	40	40	79,300	17.4	101,500	5.1	84,400	24.1	84,600	4.4	82,900	22.2	69,800	3.3
180	Full	60	60	201,300	15.9	263,700	4.6	225,100	21.5	217,000	3.9	208,300	17.2	173,400	3.2
	Part	60	60	105,500	17.0	138,700	5.0	177,700	23.0	112,600	4.2	115,400	20.5	100,900	3.5
240	Full	80	80	265,700	16.0	347,500	4.7	306,900	23.4	280,600	3.9	275,300	17.9	219,400	3.3
	Part	80	80	140,100	16.7	182,100	5.0	163,600	24.6	141,400	4.2	150,000	21.6	115,800	3.5
360	Full	120	120	394,700	16.0	487,600	4.3	452,300	22.1	420,300	4.0	410,200	17.5	339,300	3.3
	Part	120	120	206,000	16.9	256,000	4.6	241,100	23.2	214,400	4.3	223,200	21.2	183,500	3.7
600	Full	200	200	602,000	15.2	798,000	4.3	756,000	19.9	622,000	4.0	633,000	16.5	533,100	3.4
	Part	200	200	313,300	16.1	419,000	4.6	407,000	20.9	318,000	4.3	376,000	19.6	303,900	3.7

3/5/14

Performance Standard (AHRI/ISO/ASHRAE 13256-2)

The performance standard AHRI/ASHRAE/ISO 13256-2 became effective January 1, 2000. This new standard has three major categories: Water Loop, Ground Water, and Ground Loop.

Unit of Measure: The Cooling COP

The cooling efficiency is measured in EER (US version measured in Btuh per Watt. The Metric version is measured in a cooling COP (Watt per Watt) similar to the traditional COP measurement.

Pump Power Correction Calculation

Within each model, only one water flow rate is specified for all three groups and pumping Watts are calculated using the following formula. This additional power is added onto the existing power consumption.

- Pump power correction = (gpm x 0.0631) x (Press Drop x 2990) / 300

Where 'gpm' is waterflow in gpm and 'Press Drop' is the pressure drop through the unit heat exchanger at rated water flow in feet of head.

ISO Capacity and Efficiency Calculations

The following equations illustrate cooling calculations:

- ISO Cooling Capacity = Cooling Capacity (Btuh) x 3.412
- ISO EER Efficiency (W/W) = ISO Cooling Capacity (Btuh) x 3.412 / [Power Input (Watts) + Pump Power Correction (Watt)]

The following equations illustrate heating calculations:

- ISO Heating Capacity = Heating Capacity (Btuh) x 3.412
- ISO COP Efficiency (W/W) = ISO Heating Capacity (Btuh) x 3.412 / [Power Input (Watts) + Pump Power Correction (Watt)]

Test Conditions

	ISO/AHRI 13256-2 WLHP	ISO/AHRI 13256-2 GWHP	ISO/AHRI 13256-2 GLHP
Cooling			
Liquid Entering Indoor Side - °F	53.6	53.6	53.6
<i>Standard Rating Test</i>			
Liquid Entering Heat Exchanger - °F	86	59	77
<i>Part-load Rating Test</i>			
Liquid Entering Heat Exchanger	86	59	68
Fluid Flow Rate	*	*	*
Heating			
Liquid Entering Indoor Side - °F	104	104	104
<i>Standard Rating Test</i>			
Liquid Entering Outdoor-side Heat Exchanger - °F	68	50	32
<i>Part-load Rating Test</i>			
Liquid Entering Outdoor-side Heat Exchanger	68	50	41
Fluid Flow Rate	*	*	*

NOTES: *Flow rate is specified by the manufacturer
 WLHP = Water Loop Heat Pump; GWHP = Ground Water Heat Pump;
 GLHP = Ground Loop Heat Pump

The Aston Series GXW

GXW Features

Heavy gauge insulated sheet metal cabinet to reduce noise

Factory installed fused or non-fused disconnect to isolate electrical supply

Internal class J/CC fusing for protection of electrical components

Sophisticated microprocessor control with robust safety controls and advanced freeze detection

Optional factory installed pressure gauges

Stainless steel bi-directional TXV for precise superheat control

Dual scroll compressors for efficiency and reliability

High efficiency brazed plate heat exchangers for efficiency and compact size

Fully insulated heat exchanger, refrigerant piping, and water lines to prevent condensation at reduced fluid operating temperatures

Heavy gauge steel welded frame to reduce vibration

Small modular design for application flexibility

Vibration absorbers and isolation loops to mitigate refrigerant leaks due to vibration

Fork truck pockets for maneuverability



The GXW Series cont.

GeoStar is proud to announce the upgrade of the Aston GXW Reversible Chiller Series with premium efficiency, additional safety features, improved serviceability, in a compact footprint. This product comes with new electrical features such as a low voltage emergency stop button, factory mounted, internal disconnect, and IntelliStart. With internal, finger-touch fusing the GXW Reversible Chiller Series is protected against large current faults that may occur. The control panel was designed with the technician in mind by dividing high and low voltage, a removable, hinged lockable service door, and plenty of space for installation and diagnostics. Additional features and improvements are listed below:

GXW Reversible Chiller Highlights

- Capacities ranging from 120-600 MBtu/h output
- Complete commercial voltage selection of 208-230V/60Hz/3ph, 460/60/3, 575/60/3
- Oversized brazed plate heat exchangers offer high efficiency with industry low waterside pressure drop
- True-dual brazed plate heat exchangers provide better part load efficiencies compared to two single-circuit evaporators
- Compressor suction/discharge tubes come with braided stainless steel vibration absorbers to dampen compressor vibration on system piping
- Heavy gauge, galvanized steel enclosure with hinged access panels that can easily be removed for ease of service
- Fork pockets and lifting points in the frame enable maneuverability for installation and shipment
- Factory installed pressure/temperature port externally accessible for improved serviceability
- Low-voltage emergency stop button disable compressor operation
- Finger-touch safe power fuses provide circuit protection
- Primary fusing to control transformer to protect low voltage components from spikes in current fault
- Rugged plug assembly wiring harness provides a solid yet serviceable connection for control wiring to the control panel.
- Short circuit current rating up to 100kA with fused disconnect and phase guard option
- Temperature setpoint control

Wide array of standard factory installed options including:

- Factory mounted, internally wired, rotary-style, non-fused disconnect
- 2 1/2" dial-type refrigerant pressure gauges factory mounted below the control panel aid the technician in system diagnostics
- FX10 Controls with N2, LonWorks, BACnet, or non-communicating
- IntelliStart reduces compressor in-rush current by 40% meanwhile reducing mechanical shock on refrigerant tubing due to high motor start-up torque
- Phase guard monitor provides phase reversal, phase imbalance, and loss of phase protection

Inside the GXW Series

Cabinet

All unit frames are constructed of heavy gauge steel channel and painted with a corrosion resistant black, polyester, powder coat paint. The optional sheet metal cabinets are constructed of heavy gauge galvanized sheet steel painted with white, polyester, powder coat paint rated at more than a 1,000 hours salt spray rating. The frame includes fork truck access pockets in two dimensions and lifting points for easy maneuvering during installation and servicing.

Compressors

Reversible chillers use high efficiency R-410A, hermetically sealed, scroll compressors that are mounted on rubber grommets for vibration isolation. Scroll compressors provide high efficiency while providing greater tolerance to liquid refrigerant entering the suction port.

Vibration Absorbers

Vibration absorbers are factory installed on every compressor suction and discharge tube to dampen the vibrations introduced by compressor on the refrigerant piping. These absorbers are constructed from corrugated copper tubing wrapped with stainless steel wire braid to provide strength and flexibility.

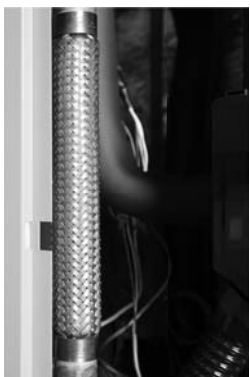

Electrical Box

Unit controls feature quick connect wiring harnesses for easy servicing. Separate knockouts for low voltage, and two for power on two sides allow easy access to the control box. A large 75VA transformer assures adequate control's power for accessories. Flexible FX10 microprocessor control is included, featuring several innovations. See Controls section for more information.



Water Connections

All water line connections are Victaulic grooved nipples for ease of installation with optional connection kits. Factory installed thermistors are used on all water lines and can be viewed through the microprocessor interface tool. Pressure ports are also added at the factory for easy service access.

Thermostatic Expansion Valve

All reversible chillers utilize balanced port, bi-directional, thermostatic expansion valves (TXV) for refrigerant metering. These valves have stainless steel capillary tube and bulb for improved robustness over conventional copper sensing capillary lines. The valve consists of a laser-welded power-head, forged brass valve body and diaphragm optimized for R-410A applications. This valve design allows precise refrigerant flow in a wide range of entering water variation geothermal systems.



Water-to-Refrigerant Heat Exchanger

Large oversized stainless steel interlaced copper-brazed plate water-to-refrigerant heat exchangers provide unparalleled efficiency. The heat exchangers have common water circuits with isolated refrigerant circuits so that in part load operation, the full mass of the heat exchanger is utilized. All heat exchangers are pressure rated to 450 psi water side and 650 psi refrigerant side. All heat exchangers, water lines, and suction lines are insulated to prevent condensation during low temperature inlet water operation.



Strainers

All reversible chillers shall have a field-installed strainer either Y-type or basket type. Strainers should be made of a suitable body such as brass with 316 stainless steel screens with a minimum of 60 mesh.

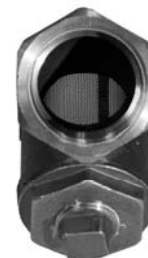

WARNING: Warranty is void if strainers are not used on the entering side of the load and source.

Service Connections and Serviceability

Two Schrader service ports are provided for each circuit on every unit. The suction side and discharge side ports are for field charging and servicing access. All valves are 7/16" SAE connections.



Inside the GXW Series cont.

Flow Switch

A flow switch or equivalent must be installed on the evaporator for each unit to be installed. If the unit is to operate as both modes (heating/cooling), a flow switch is needed on both heat exchangers.

Differential Pressure Switch

A differential pressure switch can be used in place of a flow switch. The differential switch must be capable of pressure range as indicated in the pressure drop tables.

4-Way Reversing Valve

Envision units feature a reliable all-brass pilot operated refrigerant reversing valve. The reversing valve operation is limited to change of mode by the control to enhance reliability.



Vibration Isolation

Units are shipped with heavy duty, durometer selected rubber grommets to reduce sound that can be transmitted through the floor via the frame (see grommets below). For additional sound attenuation, optional heavy duty spring isolation can reduce sound levels by 3 dBA (see springs below) can be purchased as an accessory.



Grommets Standard



Heavy Duty Mounting Springs Optional
IS-325-01 (GXW120-360)
IS-750-01 (GXW600)

Cabinet

All reversible chiller frames are constructed of heavy gauge steel channel and painted with corrosion resistant black, polyester, powder coat paint. The frame includes fork truck pockets and lifting points to assist in maneuverability of the product during installation. The reversible chillers come with an enclosure that provides additional sound attenuation, protection of the electrical and refrigeration systems, and makes the product more aesthetically pleasing. The enclosure is constructed of heavy gauge galvanized steel painted with gray textured, polyester, powder coat paint rated at more than 1,000 hours salt spray rating. The enclosure includes heavy duty hinged doors that can be easily removed for improved serviceability.



Control Panel

Reversible chiller control panel features a heavy-duty, hinged service door with a convenient user interface display for ease of service and installation. The keyed service door features a low voltage emergency stop button with an optional factory mounted disconnect switch. The left interior of the control panel features high voltage components such as the electrical disconnect, fuses, and compressor contactors.



The right interior of the panel features the FX10 main control board, expansion board, control transformer, and 24 VAC terminal strip for control wiring. The control panel was designed with the technician in mind to provide convenient, clear wiring with plenty of working space.

Electrical Disconnect

A factory mounted, internally wired, disconnect is available to provide electrical isolation from high voltage supply at the heat pump. Separate circuit protection must be field installed in the power wiring and must comply with National Electric Code (NEC) and/or local codes. Disconnect features include:

- Non-fused, rotary disconnect with "on/off" position
- Door interlocked, external pistol handle keeps door closed when disconnect is "on"
- "Lockout/Tagout" feature to keep the unit "off" during service
- Complies with NEC Article 440-14

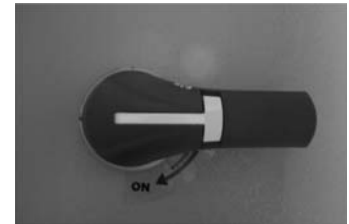

Short Circuit Current Rating

An optional factory mounted, fused disconnect provides the same benefits as the non-fused version yet increases the short circuit current rating, SCCR to comply with buildings with a high available fault current. Adding the fused disconnect option ensures the equipment will comply with NEC Article 409. Separate circuit protection must be field installed in the power wiring and must comply with National Electric Code (NEC) and/or local codes. Disconnect features include:

Inside the GXW Series cont.

- Increases SCCR to 100 kA
- Door interlocked, external pistol handle keeps door closed when disconnect is “on”
- “Lockout/Tagout” feature to keep the unit “off” during service
- Complies with NEC Article 440-14
- Complies with NEC Article 409 for Short Circuit Current Rating

Emergency Stop

Reversible chillers feature a low-voltage, twist-release emergency stop button that is wired to the emergency shutdown input on the FX10 main control board. This feature enables the technician to immediately stop operation of the heat pump without shutting off the high voltage supply.



IntelliStart

The optional IntelliStart three-phase soft starter will reduce the normal start current (LRA) by 40%. Using IntelliStart also provides a substantial reduction in vibration, reduces startup noise, and improves the compressor's start behavior.

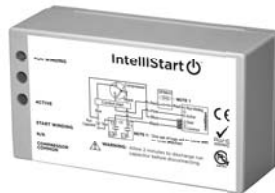

(Available on GXW120-240, 460/60/3 units only)

Phase Guard

Factory mounted phase guard device is available to protect the compressor against loss of phase, reverse rotation, or phase imbalance.

Compressor Protection Module

Model size 600 come with external compressor protection module that provides additional motor protection such as reverse phase detection and a pre-wire thermistor. All other models have internal overload protection without reverse phase detection.

Fuses

Reversible chillers come with non-indicating CUBEFuse which is a finger-safe, time-delay, power fuse with a small footprint, Class J rating, and have high fault interrupting rating. CUBEFuse includes dual-element fuse construction that can withstand inrush current yet still allow low let-through currents during a fault condition.



Controls - FX10

FX10 Microprocessor and BAS System

Standard Features

- Anti Short Cycle
- High Pressure Protection
- Low Pressure Protection
- Freeze Detection
- Loss of Charge Detection
- Random Start
- Display for diagnostics
- Reset Lockout at disconnect or through BAS
- 1 Accessory outputs
- Optional BAS add-on controls
- Compressor Lead/Lag
- Temperature setpoint control

DDC Operation & Connection

Other optional network protocol boards that can be added to the FX10 are:

- Johnson Control N2
- LonWorks
- BACnet
 - MS/TP @ 19,200 Baud rate
 - Limit devices to 30 on a single trunk line.

Control and Safety Feature Details

Emergency Shutdown

The emergency shutdown mode can be activated by a command from a facility management system or a closed contact on BI-2. The default state for the emergency shutdown data point is off. When the emergency shutdown mode is activated, all outputs will be turned off immediately and will remain off until the emergency shutdown mode is de-activated. The first time the compressor starts after the emergency shutdown mode has been de-activated, there will be a random start delay present.

Lockout Mode

Lockout mode can be activated by any of the following fault signals: refrigerant system high pressure, refrigerant system low pressure, heating freeze detection, cooling freeze detection, and compressor current sensor. When any valid fault signal remains continuously active for the length of its recognition delay, the controller will go into fault retry mode, which will turn off both compressors. After the compressor short cycle delay, the compressors will attempt to operate once again. If three consecutive faults occur in 60 minutes, the unit will go into lockout mode, turning off the compressor(s), enabling the alarm output until the controller is reset. If the control faults due to the low pressure input being open during the pre-compressor startup check, the control will go into lockout mode immediately, disabling the compressors from starting and enabling the alarm output. The lockout condition can be reset by powering down the controller, by a command from the BAS, or by the holding the ESC and Return keys on the user interface for 5 seconds. NOTE: See freeze detection section for more detail.

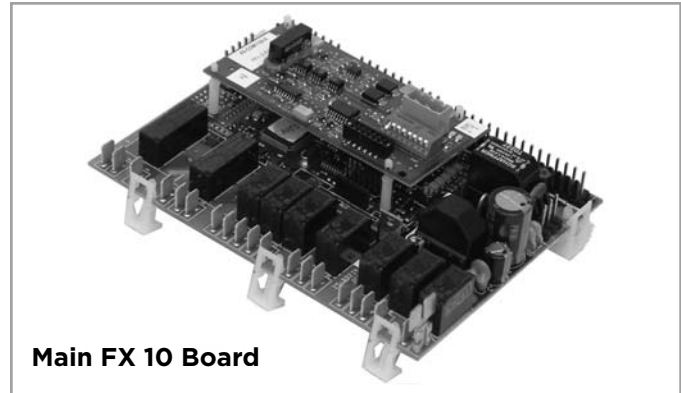

Display (Medium User Interface - MUI)

One local display is standard on all units. Up to 2 displays, either 1 local and 1 remote, or 2 remote. (A 2-display configuration requires identical displays.) Local display can be up to 3 meters from the controller, power supply, and data communication. Remote display can be up to 300 meters from the controller. Remote display must be independently powered with data communication done via 3 pole shielded cable.



Control Timing & Fault Recognition Delays

Lead compressor "ON" delay	90 seconds
Minimum compressor "ON" time	5 minutes
(except for fault condition)	
Short cycle delay	5 minutes
Random start delay	0-120 seconds
High pressure fault	<1 second
Low pressure fault	30 seconds
Freeze detection fault	0-30 seconds
Low pressure fault bypass	2 minutes

Controls - FX10 cont.

Reversible Chiller Advanced Freeze Detection System

The reversible chiller source and load heat exchangers are protected by a multi-sourced temperature logic strategy. The temperature logic is based upon the refrigerant temperature sensed as the refrigerant is about to enter the heat exchanger; while entering and leaving water temperatures are being used as correlating factors. The detection scheme is shown as basic and advanced algorithms.

Basic Freeze Detection Operation: “Comp1 or Comp2 Freeze” Alarm

This alarm can be triggered by one of two detection schemes.

Hard Limit Freeze Detection

If the refrigerant temperature drops below the freeze detection setpoint by 1.8°F, the associated compressor is locked out immediately regardless of any other factors and requires a manual reset. **NOTE: This Lockout produces a “Comp 1 or Comp 2 Freeze” error on the MUI display.**

Freeze Detection

The refrigerant temperature is compared to the freeze detection setpoint (15°F [antifreeze] or 33°F [water] field selectable), and if the temperature falls below the setpoint for 30 continuous seconds, the associated compressor will be halted. This function becomes enabled after the first two minutes of compressor operation. Three such events in 60 minutes will trigger a compressor lockout that requires a manual reset.

NOTE: This Lockout produces a “Comp 1 or Comp 2 Freeze” error on the MUI display.

In addition to the above:

Entering Water Temperature Influence

If the entering water temperature of the evaporative heat exchanger is within 10°F of the freeze setpoint, the previously mentioned two minute delay will be eliminated. This allows the freeze detection to operate immediately when the compressor starts based on entering water temperature.

Leaving Water Temperature Influence

If the leaving water temperature of the evaporative heat exchanger is within 10°F of the freeze setpoint, the previously mentioned 30 second delay will begin to be proportionately reduced, ending at a 1 second delay when the leaving water temperature is 1.5°F above the freeze setpoint.

Dual Circuited Heat Exchanger Protection

A low temperature condition on either refrigerant circuit will prevent the start of both compressors. If the low temperature condition exists for 5 minutes when both compressors are off, a lockout is triggered for both compressors. However, if for instance both compressors are operating and circuit 1 experiences a refrigerant temperature below the freeze detection setpoint such that compressor 1 is halted, compressor 2 will not be halted as a result.

Advanced Freeze Detection Operation: “Pre Freeze” Alarm

Predictive freeze condition detection:

If the refrigerant temperature is within 7.2°F of the freeze detection setpoint, the predictive freeze detection algorithm is enabled, and if the logic determines that a freeze condition is likely to happen based on current conditions, the compressor of the involved refrigerant circuit is immediately stopped. Three (3) such events in 60 minutes will trigger a compressor lockout that requires a manual reset. In the absence of such a condition, the compressor is allowed to operate so that the refrigerant temperature may eventually be at the threshold of the freeze detection setpoint. **NOTE: This Lockout produces a “Pre Freeze” detection error on the MUI display.**

Capacity Limiting

If the leaving water temperature drops to 1.8°F above the freeze detection setpoint, the lead compressor is halted. When the leaving water temperature rises to 3.6°F above the freeze detection setpoint, it will be allowed to resume operation. This limiting is allowed to repeat indefinitely with no lockout or indication on the display.

If the leaving water temperature drops to the freeze detection setpoint, the lag compressor is halted. When the leaving water temperature rises to 1.8°F above the freeze detection setpoint, it will be allowed to resume operation. This limiting is allowed to repeat indefinitely with no lockout or indication on the display.

High Pressure

The high-pressure switch shall be a normally closed (NC) switch that monitors the systems refrigerant pressure. If the input senses the high-pressure switch is open it must disable the compressor output immediately and count the fault. The compressor minimum on time does not apply if the high-pressure switch opens. The compressor will not restart until the compressor short cycle time delay has been satisfied.

Low Pressure

The low-pressure switch shall be a normally closed (NC) switch that monitors the systems refrigerant pressure. The input 15 seconds before compressor start up and then ignored for the first 2 minutes after the compressor output (BO-2) is enabled. If the switch is open continuously for 30 seconds during compressor

Controls - FX10 cont.

operation the compressor output (BO-2) will be disabled. The compressor will not restart until the compressor short cycle time delay has been satisfied.

Alarm Outputs

The control has two alarm outputs, one for each compressor circuit. These 24VAC outputs are designated as LC1 (compressor 1) and LC2 (compressor2) on the low voltage terminal board.

Test Mode

By holding the ESC and down arrow keys on the MUI for 5 seconds will put the control into test mode. In test mode the random start delay and the compressor fixed on delay time will both be shortened to 5 seconds and the reversing valve will be allowed to cycle with out shutting down the compressor. If an MUI is connected to the control LED 8 will flash and the words "Test Mode Enabled" will be shown on the LCD display when the control is in test mode. Test mode will be disabled after a power cycle, 30 minute timeout, or by holding the ESC and Up arrow keys on the MUI.

Sequence of Operation

Power Fail Restart

When the controller is first powered up, the outputs will be disabled for a random start delay. The delay is provided to prevent simultaneous starting of multiple heat pumps. Once the timer expires, the controller will operate normally.

Random Start Delay

This delay will be used after every power failure, as well as the first time the compressor is started after the control exits the unoccupied mode or the emergency shutdown mode. The delay should not be less than 1 second and not longer than 120 seconds. If the control is in test mode the random start delay will be shortened to 5 seconds.

Lead Compressor Start Delay Time

The Lead Compressor Fixed On Delay Time will ensure that the lead compressor output is not enabled for 90 seconds after the control receives a call to start the compressor. This delay is adjustable from 30 – 300 seconds over a BAS or a MUI. If the control is in test mode the Lead Compressor Start Delay Timer will be shortened to 5 seconds.

Lag Compressor Start Delay Time

The Lag Compressor Fixed On Delay Time will ensure that the lag compressor output is not enabled for 90 seconds after the control receives a call to start the compressor. This delay is adjustable from 30 – 300 seconds over a BAS or a MUI. If the control is in test mode the Lag Compressor Start Delay Timer will be shortened to 5 seconds.

Compressor Minimum On Delay

The compressor minimum on delay will ensure that the compressor output is enabled for a minimum of five (5) minutes each time the compressor output is enabled. This will apply in every instance except in the event the high pressure switch is tripped, freeze protection, or emergency shutdown then the compressor output will be disable immediately.

Compressor Minimum Off Delay Time

The compressor minimum off time delay will ensure that the compressor output will not be enabled for a minimum of five (5) minutes after it is disabled. This allows for the system refrigerant pressures to equalize after the compressor is disabled.

Compressor Lead/Lag

Compressor lead/lag is a standard part of the FX10 control system. The unit is shipped from the factory with lead/lag enabled. Lead/lag can be activated through the unit mounted user interface.

Heating Cycle

The control will run the unit in heating mode when there is a command on the O/B terminal on the terminal board.

Cooling Cycle

The control will run the unit in cooling mode when there is no command on the O/B terminal on the terminal board.

MUI Alarm History Reporting

If a fault occurs the fault will be recorded in history for display on the medium user interface in the History Menu. Each fault type will be displayed in the history menu with a number between 0 and 3. A reading of 3+ will mean that fault has occurred more than three times in the past. The history menu can be cleared with a power cycle only. Alarm date and time are not included in the history.

Controls - FX10 cont.

Inputs and Outputs Configuration

Field Selectable Options

Load and Source Freeze Detection Setpoint

The freeze detection setpoint input allows you to adjust the freeze detection setpoint for either the load or source sides of the heat pump. When the jumper is installed on BI-5 the load freeze detection setpoint is factory set for 30°F. When the jumper on BI-5 is removed the load freeze detection setpoint will be 15°F. When the jumper is installed on BI-4 the source freeze detection setpoint is factory set for 33°F. When the jumper on BI-4 is removed the source freeze detection setpoint will be 15°F.

NOTE: Piping circuit must be antifreeze protected to the set levels or the warranty will be voided.

Accessory Output

The Accessory Output will be energized 90 seconds prior to the lead compressor output being energized. When both compressor outputs are turned off the accessory output will be deactivated immediately. This output is selectable for normally open or normally closed operation through the Medium User Interface or through the Building Automation System.

Reversible Chiller Setpoint Control

This control software is by default set to operate in 'Aquastat' mode, which requires external setpoint logic to generate the Y1 or Y2 call. The mode may be changed to 'Setpoint' by use of the 'Settings' menu in the MUI in the 'Mode' item which is on the 5th line from the top.



CAUTION! Setpoint mode is not recommended on applications that have more than two water-to-water heat pumps installed. Unique temperature setting should be set for each unit on a common load.

To operate in setpoint mode, consider the following:

- The selected mode must be changed from Aquastat to Setpoint
- The 'Y1' input must be activated. This may be done by connecting 'R' to 'Y1' on the terminal board, or by commanding Y1 to 'ON' in the Maint menu of the MUI, or by commanding the ComprEnable network variable from the BAS.
- The Heat/Cool mode is by default in the cooling mode, and may be set to heating by connecting R to O/B on the terminal board, or by commanding the 'B' item in the Maint menu of the MUI, or by commanding the reversing valve variable from the BAS network.
- The setpoint mode temperature sensor can be selected to either Load LW Temp (Leaving Water) or Load EW Temp (Entering Water Temp). The default is set for Entering Water Temp control.
- The cooling setpoint and the heating setpoint are two separate setpoints, and can be adjusted in the MUI Settings menu.

- When the controlling temperature sensor is set to select the Load EW Temp, the setpoint control will operate in a PID (Proportional-Integrating-Derivative) mode. In this mode, the temperature rate of change and direction of change will be part of deciding whether or not to add or reduce capacity. Additionally the amount of difference between setpoint and temperature AND the length of time that the difference existed are used to determine if adding or reducing capacity is needed.
 - o The tuning parameters for this mode should only be adjusted if you know why you are choosing the value that you plan to use. You should keep a permanent record of the beginning values and record any changes that you make. The parameters used in PID operation and their (default values) are:
 - D NegThrshld (-0.03)
 - Int Rate (200)
 - Stage Delay (30)
 - Gain (2)
 - D PosThrshld (0.04)
 - PIDY1 Ref (7.2)
 - PID Y1 Diff (7)
 - PID Y2RefShift (5)
 - PID Y2 Diff (6)
- When the controlling temperature sensor is set to select the Load LW Temp, the setpoint control will operate strictly in a proportional mode with offsets and differentials used to determine the appropriate capacity to use. In this mode, the following parameters are used:
 - Stage Delay (30)
 - Gain (2)
 - PIDY1 Ref (7.2)
 - PID Y1 Diff (7)
 - PID Y2RefShift (5)
 - PID Y2 Diff (6)
- The default values were used in the test lab and seem to be a reasonably good beginning point for parameter settings.

Control Accessories

- A99 Sensor
- MUI (LCD User interface) for diagnostics and commissioning
- MUIK3 - Panel Mount, Portable
- MUIK4 - Wall Mount

GXW Application Data

1.0. Minimum Fluid Volume

- A. Water-to-water heat pumps require a minimum amount of source and load side fluid volume to ensure accurate and stable temperatures during system operation. For normal air conditioning type applications, it is recommended to use at least 7 gallons/ton.
- B. Applications that require more precise temperature control or low loading will occur the minimum fluid volume shall be no less than 10 gallons/ton. Installation of a buffer tank that will properly mix the fluid is recommended.

1.1. Water-to-Water Heat Pump Sizing

- A. Heat pumps should be adequately sized for optimal system efficiency and run time. Oversizing by more than 15% can diminish performance resulting in higher power consumption, short cycling of compressors, and unstable conditioning temperatures.
- B. In applications where the minimum load is significantly less than the design condition, it is better to install 2 smaller heat pumps for load matching rather than a single large heat pump.

1.2. Heat Pump Piping

- A. Multiple heat pumps can be installed in series or parallel configurations. The preferred system design is to pipe the equipment in parallel due to its simplicity and flexibility. In parallel systems, the heat pump equipment can vary in size as long as flow rate and system volume are accounted for.
- B. Piping equipment in series is not desired; however, it can be done if proper guidelines are followed. Always observe proper temperature and flow rate requirements for each unit. Sometimes this method is desired to achieve larger temperature differences.

1.3. Strainers

- A. All brazed-plate heat exchangers shall have a strainer within 8 ft of the water/brine inlet. It is highly recommended to use a minimum of 60 mesh in order to provide maximum filtration. In any case, the strainers should never have a mesh size less than 20.
- B. Failure to install proper strainers and perform regular service can result in serious damage to the unit, and cause degraded performance, reduced operating life and failed compressors. Improper installation of the unit (which includes not having proper strainers to protect the heat exchangers) can also result in voiding the warranty.
- C. Strainers should be selected on the basis of acceptable pressure drop, and not on pipe diameter. The strainers selected should have a pressure drop at the nominal flow rate of the units; low enough to be within the pumping capacity of the pump being used.

1.4. Flow Sensing Devices

- A. A flow switch or equivalent must be installed on the evaporator for each unit to be installed. If the unit is to operate as both modes (heating/cooling), a flow switch is needed on

both heat exchangers.

- B. A differential pressure switch can be used in place of a flow switch. The differential switch must be capable of pressure range as indicated in the pressure drop tables.

1.5. Water Quality

- A. **General:** Reversible chiller systems may be successfully applied in a wide range of commercial and industrial applications. It is the responsibility of the system designer and installing contractor to ensure that acceptable water quality is present and that all applicable codes have been met in these installations.
- B. **Water Treatment:** Do not use untreated or improperly treated water. Equipment damage may occur. The use of improperly treated or untreated water in this equipment may result in scaling, erosion, corrosion, algae or slime. The services of a qualified water treatment specialist should be engaged to determine what treatment, if any, is required. The product warranty specifically excludes liability for corrosion, erosion or deterioration of equipment.

The heat exchangers in the units are 316 stainless steel plates with copper brazing. The water piping in the heat exchanger is steel. There may be other materials in the building's piping system that the designer may need to take into consideration when deciding the parameters of the water quality.

If an antifreeze or water treatment solution is to be used, the designer should confirm it does not have a detrimental effect on the materials in the system.

- C. **Contaminated Water:** In applications where the water quality cannot be held to prescribed limits, the use of a secondary or intermediate heat exchanger is recommended to separate the unit from the contaminated water.

The following table outlines the water quality guidelines for unit heat exchangers. If these conditions are exceeded, a secondary heat exchanger is required. Failure to supply a secondary heat exchanger where needed will result in a warranty exclusion for primary heat exchanger corrosion or failure.



WARNING: Must have intermediate heat exchanger when used in pool applications.

GXW Application Data cont.

1.6. Insulation

- A. Heat pumps are built with factory installed insulation on any surface that may be subject to temperatures below the room dew point.

Surface Condensation Chart

Room Ambient Condition	Surface Temperature		
	50°F	35°F	0°F
Normal (Max 85°F, 70% RH)	1/2"	3/4"	1"
Mild (Max 80°F, 50% RH)	1/8"	1/4"	1/2"
Severe (Max 90°F, 80% RH)	3/4"	1"	2"

1.7. Brine Applications

- A. Applications where the leaving fluid temperature goes below 40°F a suitable brine solution must be used. Failure to do so can cause immediate damage to the system. The brine must be approved for use with heat exchangers. Automotive antifreeze solutions are not suitable for use in brazed plate heat exchangers.
- B. The freeze detection must be adjusted appropriately for brine applications. The brine solution concentration should be at least 15°F below the lowest leaving fluid temperature.

Water Quality Guidelines

Material	316 Stainless Steel	
	pH	Acidity/Alkalinity
Scaling	Calcium and Magnesium Carbonate	7 - 9 (Total Hardness) less than 350 ppm
Corrosion	Hydrogen Sulfide	Less than 1 ppm
	Sulfates	Less than 200 ppm
	Chlorine	Less than 0.5 ppm
	Chlorides	Less than 300 ppm
	Carbon Dioxide	10 - 50 ppm
	Ammonia	Less than 20 ppm
	Ammonia Chloride	Less than 0.5 ppm
	Ammonia Nitrate	Less than 0.5 ppm
	Ammonia Hydroxide	Less than 0.5 ppm
	Ammonia Sulfate	Less than 0.5 ppm
Iron Fouling (Biological Growth)	Total Dissolved Solids (TDS)	1000 - 1500 ppm
	LSI Index	+0.5 to -0.5
Iron Fouling (Biological Growth)	Iron, FE ²⁺ (Ferrous) Bacterial Iron Potential	< 0.2 ppm
	Iron Oxide	Less than 1 ppm, above this level deposition will occur
Erosion	Suspended Solids	Less than 10 ppm and filtered for max. of 600 micron size
	Threshold Velocity (Fresh Water)	< 6 ft/sec

NOTES: Grains = ppm divided by 17
mg/L is equivalent to ppm

2/22/12

GXW Selection Process

To achieve optimal performance, proper selection of each heat pump is essential. The easiest and most accurate method to size and select heat pump equipment is to use the heat pump selection program. Specific design information such as temperatures, voltages, and flow requirements are entered directly into the program so that the correct heat pump is chosen. The heat pump schedule and submittal data is all generated within the heat pump selection program.

Notes before selections:

- For applications using water, the leaving water temperature must stay above 40°F.
- If leaving water temperature below 40°F is desired, the design must include a suitable brine solution.
- Water/Brine flow rates must meet the minimum and maximum criteria as established in the engineering data.
- Water quality must comply with data presented in engineering documentation.
- Contact factory for applications requiring load temperatures below 32°F

GXW Typical Piping

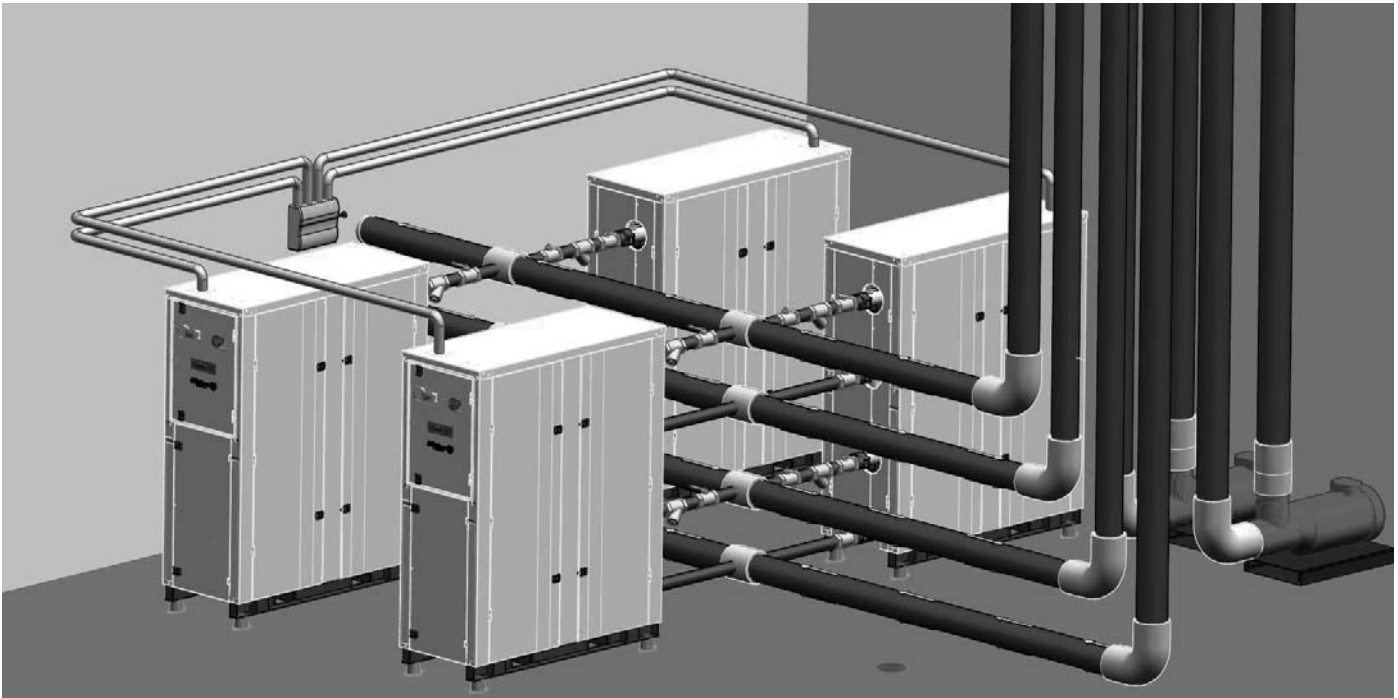

GXW Typical Piping, cont.

Standard Piping

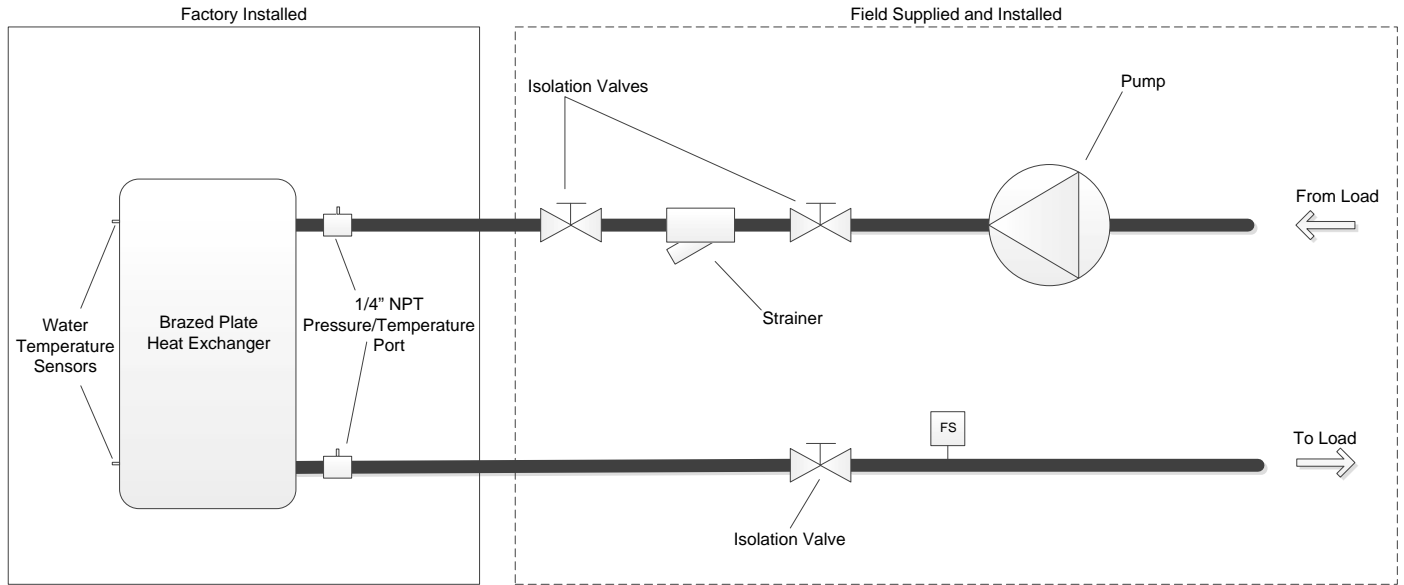

Note: System piping should have drain ports to enable flushing and cleaning of heat exchangers. On systems utilizing pumps with VFDs, an automatic flow control valve must be installed.

Pressure Regulated Piping

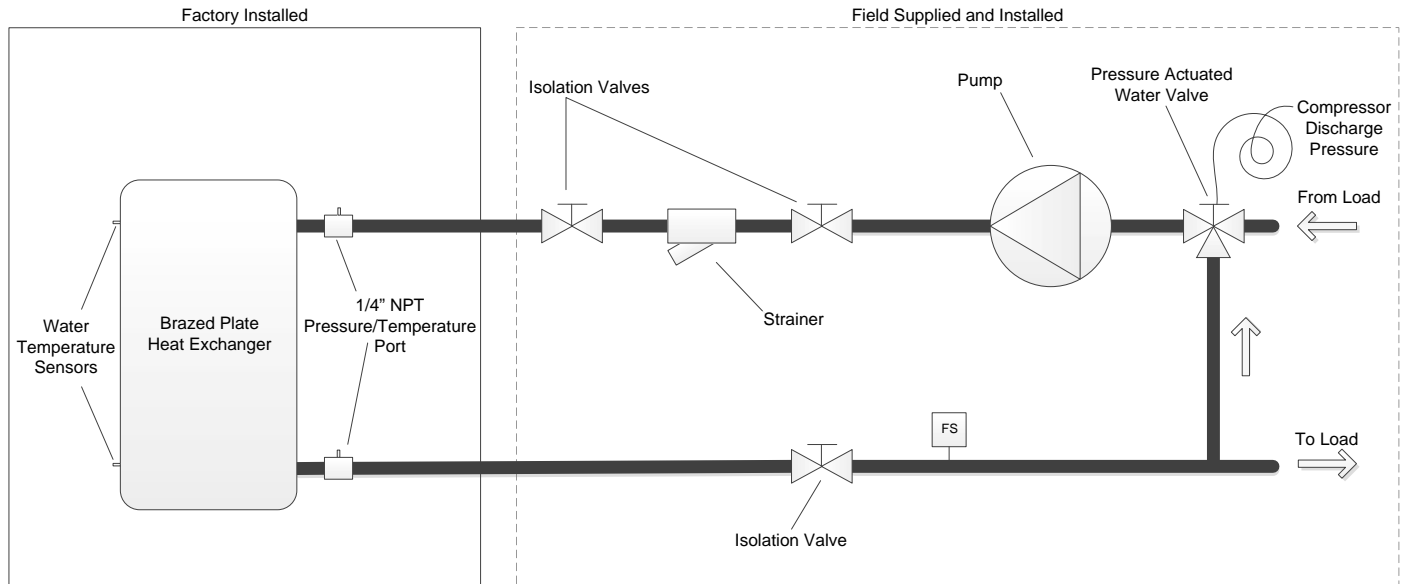

Note: System piping should have drain ports to enable flushing and cleaning of heat exchangers. On systems utilizing pumps with VFDs, an automatic flow control valve must be installed.

Physical Dimensions

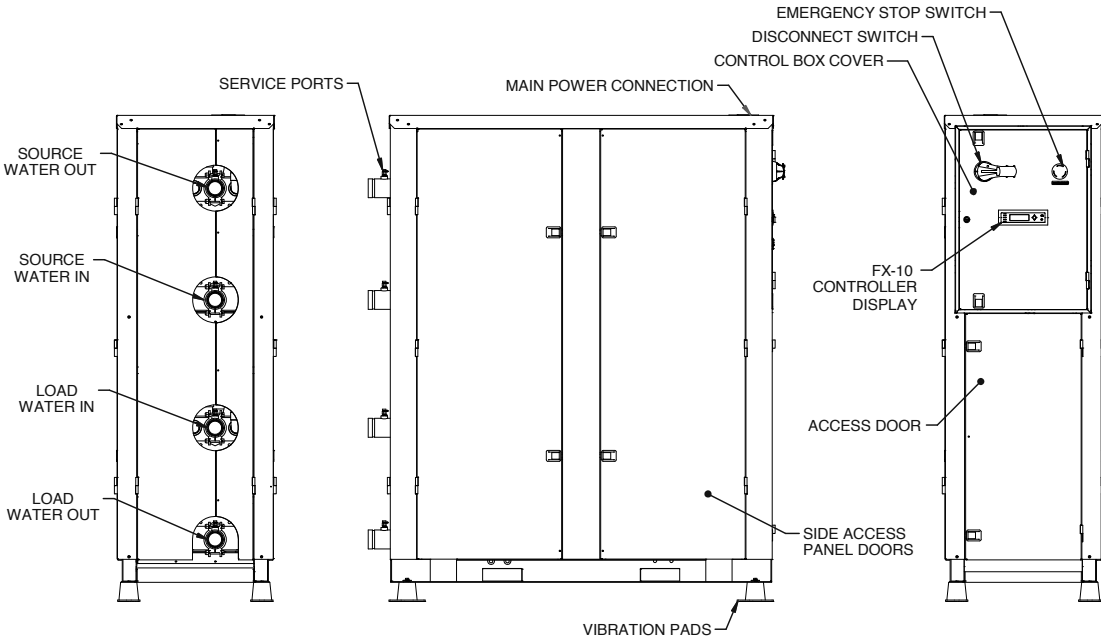

NOTES:
1. DO NOT SCALE DRAWING.

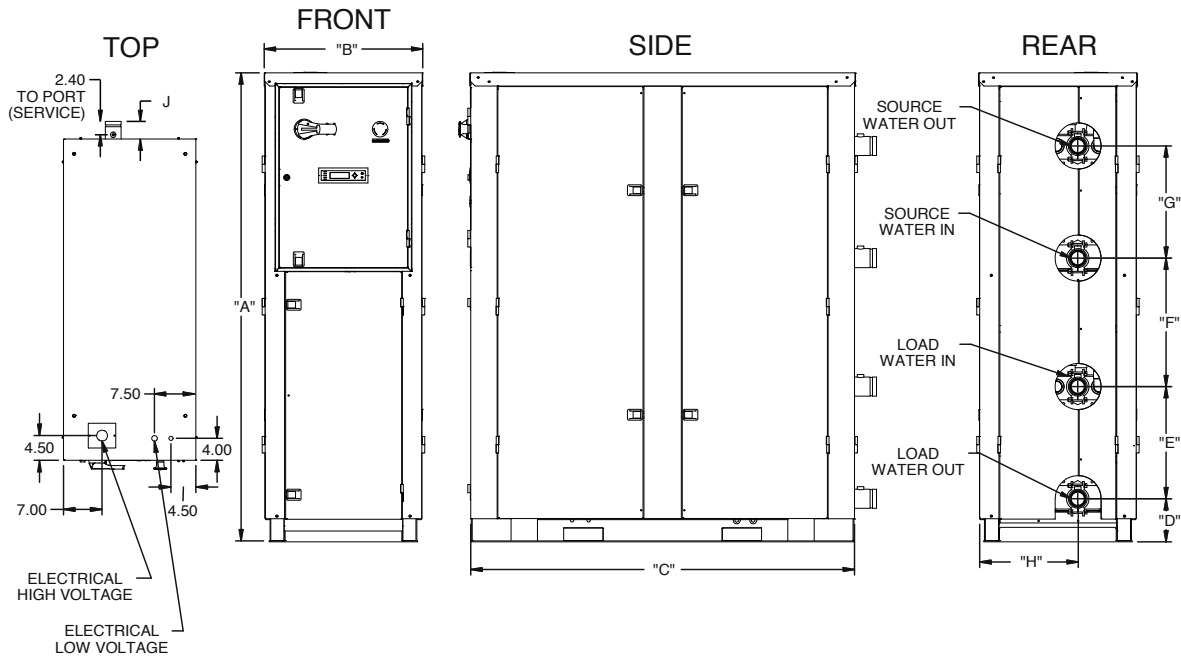

Model	A	B	C	D	E	F	G	H	J
120-180	57.3 [1455]	24.1 [612]	42.5 [1080]	5.0 [127]	17.0 [432]	8.8 [224]	17.0 [432]	11.9 [302]	4.6 [117]
240-360	64.2 [1631]	24.1 [612]	50.5 [1283]	6.9 [175]	17.0 [432]	13.9 [353]	17.0 [432]	12.1 [307]	3.6 [91]
600	71.1 [1806]	24.0 [610]	58.5 [1486]	6.5 [165]	17.0 [432]	19.5 [495]	17.0 [432]	15.0 [381]	3.2 [81]

All dimensions in inches, [mm]

5/12/14

Physical Dimensions. cont.

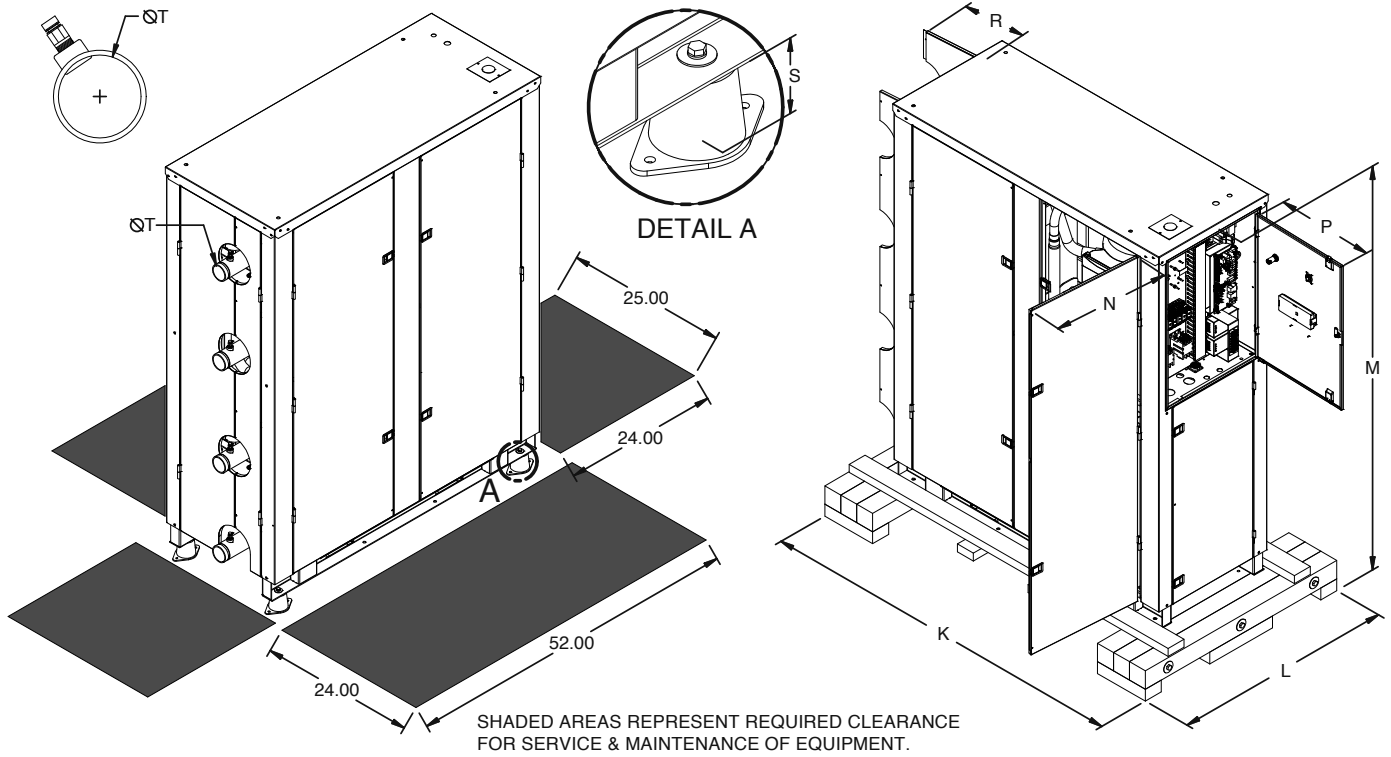

Model	K	L	M	N	P	R	S	T*
120-180	57.0 [1448]	42.0 [1067]	63.1 [1603]	15.9 [404]	19.5 [495]	9.7 [246]	1.3 [33]	2.0 [50.8]
240-360	65.0 [1651]	42.0 [1067]	69.9 [1775]	19.9 [505]	19.5 [495]	9.7 [246]	1.8 [46]	2.0 [50.8]
600	70.0 [1778]	42.0 [1067]	76.8 [1951]	22.0 [559]	19.5 [495]	12.7 [323]	1.8 [46]	2.5 [63.5]

All dimensions in inches, [mm]

*T - Units shipped with groove pipe connection

5/12/14

Vibration Isolators

Rubber Isolators

Part Number	Type	Color Code	Max Load, lbs	Deflection, in	Qty
99S502-01	RD2	Green	380	0.50	4

• Compatible with GXW120-180

Part Number	Type	Color Code	Max Load, lbs	Deflection, in	Qty
99S502-02	RD3	Green	750	0.50	4

• Compatible with GXW240-600

RD2

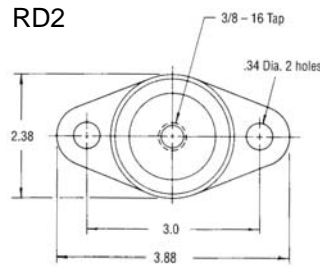

RD3

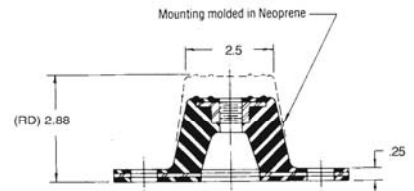
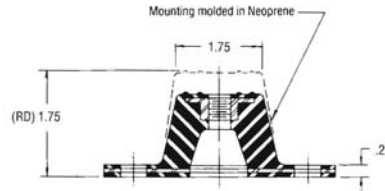
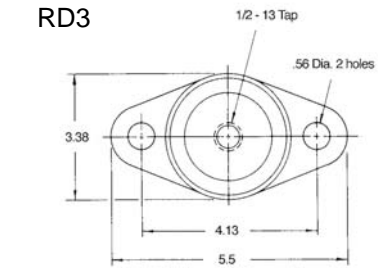

Spring Isolators

Number	Compatible With	Spring Color	Rated Capacity	Rated Deflection	Isolator Constant	Adjustment Bolt	Qty
IS-325-01	GXW120-180	Brown	325 lbs	1.23"	264 lbs/in	1/2 x 3.5	4
IS-750-01	GXW240-600	Orange	750 lbs	1.06"	707 lbs/in	1/2 x 3.5	4

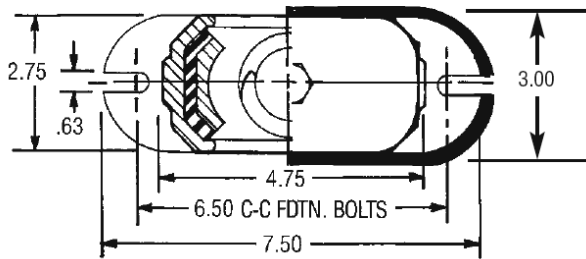

1/2 Dia. x 3.5 Long
Adjusting & Leveling Bolt

5.25 Free Ht.

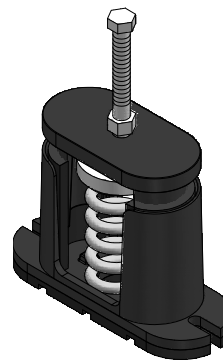
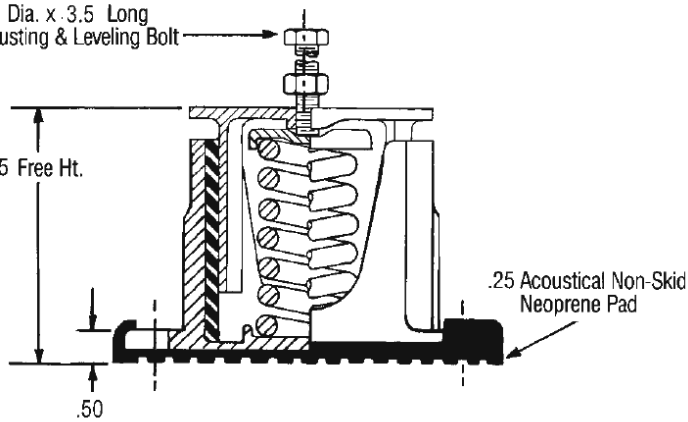

Physical Data

Model	Compressor	Refrigerant Charge*	Total Weight	
			Shipping	Installed
120	Scroll (2)	5.3	720	710
		[2.4]	[327]	[323]
180	Scroll (2)	7.8	838	844
		[3.5]	[381]	[384]
240	Scroll (2)	10.5	1130	1152
		[4.8]	[514]	[524]
360	Scroll (2)	17.9	1320	1388
		[8.1]	[600]	[631]
600	Scroll (2)	27.3	1748	1850
		[12.4]	[795]	[841]

Weights shown in Pounds, [kg]

1/30/2014

* Refrigerant per circuit in Pounds, [kg]

Add 32 lbs [15 kg] for fluid weight when full. (120)

Add 48 lbs [22 kg] for fluid weight when full. (180)

Add 64 lbs [29 kg] for fluid weight when full. (240)

Add 110 lbs [50 kg] for fluid weight when full. (360)

Add 144 lbs [65 kg] for fluid weight when full. (600)

NOTE: See page 16 for minimum fluid volume guidelines.

Electrical Data

Model	Rated Voltage	Voltage Min/Max	Compressor ¹			Total Unit FLA	Min Circ Amp	Min Fuse/HACR	Max Fuse/HACR ²
			MCC	RLA	LRA				
120	208-230/60/3	187/253	36.0	23.1	160.0	46.2	52.0	60.0	70
	460/60/3	414/506	19.0	12.2	87.0	24.4	27.5	30.0	35
	575/60/3	517/633	13.5	8.7	62.0	17.4	19.6	20.0	25
	380/60/3	342/418	19.0	12.2	95.0	24.4	27.5	30.0	35
180	208-230/60/3	187/253	45.0	28.8	235.0	57.6	64.8	70.0	90
	460/60/3	414/506	19.0	12.2	110.0	24.4	27.5	30.0	35
	575/60/3	517/633	16.5	10.9	95.0	21.8	24.5	25.0	35
240	208-230/60/3	187/253	52.2	35.2	250.0	70.4	79.2	80.0	110
	460/60/3	414/506	27.0	19.2	140.0	38.4	43.2	45.0	60
	575/60/3	517/633	19.1	14.5	100.0	29.0	32.6	35.0	45
360	208-230/60/3	187/253	75.0	48.1	351.0	96.2	108.2	110.0	150
	460/60/3	414/506	38.6	24.7	197.0	49.4	55.6	60.0	80
	575/60/3	517/633	35.0	22.4	135.0	44.8	50.4	60.0	70
	380/60/3	342/418	51.0	32.7	239.0	65.4	73.6	80.0	100
600	460/60/3	414/506	62.0	39.7	260.0	79.4	89.3	100.0	125
	575/60/3	517/633	45.0	28.8	210.0	57.6	64.8	70.0	90
	380/60/3	342/418	72.0	46.2	310.0	92.4	104.0	110.0	150

HACR circuit breaker in USA only

3/5/14

¹ - MCC, RLA, & LRA rating per compressor. Breaker & FLA sized for both compressors.

² - Equipment supplied with Class J fuses per minimum fuse size.

Compressor Protection Module

An electronic protection module is provided with compressors utilized in model size 600. This module will protect against phase reversal and phase loss at start-up. Protection is active for 5 seconds after the first second of compressor operation. In the event that either phase sequencing or phase loss has occurred the following blink sequence will display on the module.

In case of phase reverse error:



In case of phase loss error:



Antifreeze Correction

Catalog performance can be corrected for antifreeze use. Please use the following table and note the example given.

Antifreeze Type	Antifreeze % by wt	Heating		Cooling		Pressure Drop
		Load	Source	Load	Source	
EWT - °F [°C]		90 [32.2]	30 [-1.1]	50 [10]	90 [32.2]	30 [-1.1]
Water	0	1.000	1.000	1.000	1.000	1.000
Ethylene Glycol	10	0.991	0.973	0.975	0.991	1.075
	20	0.979	0.943	0.946	0.979	1.163
	30	0.965	0.917	0.920	0.965	1.225
	40	0.955	0.890	0.895	0.955	1.324
	50	0.943	0.865	0.870	0.943	1.419
Propylene Glycol	10	0.981	0.958	0.959	0.981	1.130
	20	0.969	0.913	0.919	0.969	1.270
	30	0.950	0.854	0.866	0.950	1.433
	40	0.937	0.813	0.829	0.937	1.614
	50	0.922	0.770	0.789	0.922	1.816
Ethanol	10	0.991	0.927	0.941	0.991	1.242
	20	0.972	0.887	0.901	0.972	1.343
	30	0.947	0.856	0.866	0.947	1.383
	40	0.930	0.815	0.826	0.930	1.523
	50	0.911	0.779	0.791	0.911	1.639
Methanol	10	0.986	0.957	0.961	0.986	1.127
	20	0.970	0.924	0.928	0.970	1.197
	30	0.951	0.895	0.897	0.951	1.235
	40	0.936	0.863	0.865	0.936	1.323
	50	0.920	0.833	0.835	0.920	1.399



WARNING: Gray area represents antifreeze concentrations greater than 35% by weight and should be avoided due to the extreme performance penalty they represent.

Reference Calculations

Heating Calculations: $LWT = EWT - \frac{HE}{GPM \times 500^*}$	Cooling Calculations: $LWT = EWT + \frac{HR}{GPM \times 500^*}$
--	--

NOTE: * When using water. Use 485 for 15% methanol/water or Environol solution.

Legend and Notes

Abbreviations and Definitions

ELT = entering load fluid temperature to heat pump	PSI = pressure drop in pounds per square inch
LLT = leaving load fluid temperature from heat pump	FT HD = pressure drop in feet of head
LGPM = load flow in gallons per minute	KW = kilowatt
LWPD = load heat exchanger water pressure drop	HR = heat rejected in MBTUH
EST = entering source fluid temperature to heat pump	TC = total cooling capacity in MBTUH
LST = leaving source fluid temperature from heat pump	COP = coefficient of performance (HC/KW x 3.413)
SGPM = source flow in gallons per minute	HC = heating capacity in MBTUH
SWPD = source heat exchanger water pressure drop	HE = heat of extraction in MBTUH
EER = cooling energy efficiency (TC/KW)	

Notes to Performance Data Tables

The following notes apply to all performance data tables:

- Three flow rates are shown for each unit. The lowest flow rate shown is used for geothermal open loop/well water systems with a minimum of 50°F EST. The middle flow rate shown is the minimum geothermal closed loop flow rate. The highest rate shown is optimum for geothermal closed loop systems and the suggested flow rate for boiler/tower applications.
- Water temperatures below 40°F assumes 15% antifreeze solution.
- Interpolation between ELT, EST, and GPM data is permissible.
- Operation in the gray areas is not recommended.
- Any flow rate less than 2.5 GPM/per ton requires a flow switch

flow

Pressure Drop

Model	GPM	Pressure Drop (psi)				
		30°F	50°F	70°F	90°F	110°F
120	20	0.8	0.7	0.6	0.6	0.5
	30	2.1	1.9	1.8	1.7	1.5
	40	3.3	3.1	2.9	2.8	2.5
180	30	0.9	0.8	0.7	0.7	0.6
	45	2.3	2.2	2.0	2.0	1.8
	60	3.7	3.5	3.3	3.2	2.9
240	40	1.3	1.2	1.1	1.1	1.0
	60	3.2	3.0	2.9	2.8	2.6
	80	5.0	4.7	4.6	4.4	4.2
360	60	1.3	1.2	1.1	1.0	0.9
	90	3.1	2.9	2.8	2.7	2.4
	120	4.8	4.6	4.4	4.3	3.9
600	100	2.8	2.5	2.4	2.2	2.0
	150	4.7	4.5	4.4	4.0	3.9
	200	6.4	6.2	6.1	5.7	5.6

4/29/14

Water Pressure Drop vs. Flow at 30°F

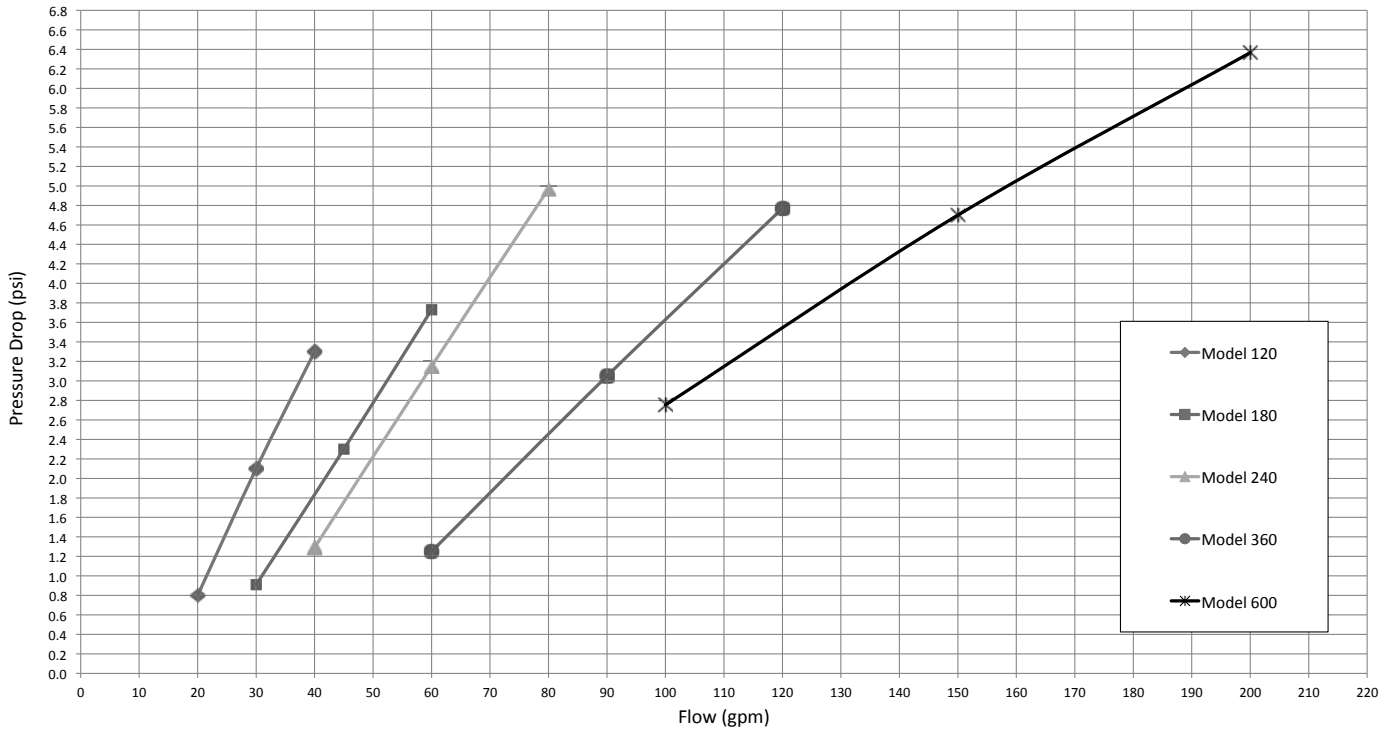

Note: Pressure drop is the same for load and source heat exchangers at 30°F fluid temperature.

GXW120 Performance Data

Heating

Source		ELT °F	Load Flow - 20 GPM						Load Flow - 30 GPM						Load Flow - 40 GPM						
EST °F	Flow GPM		LLT °F	HC MBTUH	Power kW	HE MBTUH	COP	LST °F	LLT °F	HC MBTUH	Power kW	HE MBTUH	COP	LST °F	LLT °F	HC MBTUH	Power kW	HE MBTUH	COP	LST °F	
30	30	60	72.8	128.3	7.1	104.0	5.3	23.1	68.6	128.8	6.9	105.3	5.5	23.0	66.5	129.3	6.7	106.5	5.7	22.9	
		80	92.3	122.6	9.6	89.8	3.7	24.0	88.2	123.4	9.3	91.6	3.9	23.9	86.2	124.2	9.0	93.4	4.0	23.8	
		100	111.7	117.0	12.1	75.6	2.8	25.0	107.9	118.0	11.8	77.9	2.9	24.8	106.0	119.1	11.4	80.3	3.1	24.6	
		120	131.1	111.3	14.6	61.4	2.2	25.9	127.5	112.6	14.2	64.3	2.3	25.7	125.7	114.0	13.7	67.2	2.4	25.5	
	40	60	73.3	133.0	7.2	108.6	5.4	24.6	68.9	133.5	6.9	109.8	5.6	24.5	66.7	134.0	6.7	111.0	5.8	24.4	
		80	92.6	126.3	9.7	93.4	3.8	25.3	88.5	127.2	9.4	95.3	4.0	25.2	86.4	128.2	9.1	97.3	4.1	25.1	
		100	112.0	119.6	12.1	78.2	2.9	26.1	108.1	121.0	11.8	80.9	3.0	26.0	106.1	122.3	11.4	83.5	3.2	25.8	
		120	131.3	113.0	14.6	63.0	2.3	26.8	127.6	114.7	14.2	66.4	2.4	26.7	125.8	116.4	13.7	69.7	2.5	26.5	
50	20	60	76.2	162.2	7.6	136.5	6.3	36.4	70.9	163.3	7.3	138.4	6.6	36.2	68.2	164.3	7.0	140.4	6.9	36.0	
		80	95.5	154.5	10.0	120.3	4.5	38.0	90.4	155.8	9.7	122.9	4.7	37.7	87.9	157.1	9.3	125.4	5.0	37.5	
		100	114.7	146.9	12.5	104.2	3.4	39.6	109.9	148.4	12.0	107.3	3.6	39.3	107.5	150.0	11.6	110.4	3.8	39.0	
		120	133.9	139.2	15.0	88.0	2.7	41.2	129.4	141.0	14.4	91.7	2.9	40.8	127.1	142.8	13.9	95.4	3.0	40.5	
	30	60	77.0	169.7	7.6	143.6	6.5	40.4	71.4	170.9	7.4	145.8	6.8	40.3	68.6	172.2	7.1	148.0	7.1	40.1	
		80	96.1	160.6	10.1	126.2	4.7	41.6	90.8	162.2	9.7	129.1	4.9	41.4	88.2	163.9	9.3	132.0	5.1	41.2	
		100	115.2	151.6	12.5	108.8	3.5	42.7	110.2	153.6	12.1	112.4	3.7	42.5	107.8	155.6	11.6	115.9	3.9	42.3	
		120	134.2	142.5	15.0	91.3	2.8	43.9	129.7	144.9	14.4	95.6	2.9	43.6	127.4	147.3	13.9	99.9	3.1	43.3	
	40	60	77.7	177.2	7.7	150.8	6.7	42.5	71.9	178.6	7.5	153.2	7.0	42.3	69.0	180.0	7.2	155.5	7.4	42.2	
		80	96.7	166.7	10.1	132.1	4.8	43.4	91.2	168.6	9.8	135.3	5.1	43.2	88.5	170.6	9.4	138.5	5.3	43.1	
		100	115.6	156.2	12.6	113.4	3.6	44.3	110.6	158.7	12.1	117.4	3.8	44.1	108.1	161.2	11.6	121.5	4.1	43.9	
		120	134.6	145.8	15.0	94.6	2.9	45.3	129.9	148.8	14.4	99.5	3.0	45.0	127.6	151.7	13.9	104.4	3.2	44.8	
70	20	60	80.1	200.8	8.0	173.4	7.3	52.7	73.5	202.4	7.7	176.1	7.7	52.4	70.2	204.0	7.4	178.8	8.1	52.1	
		80	99.0	190.1	10.5	154.4	5.3	54.6	92.8	192.1	10.0	157.8	5.6	54.2	89.7	194.0	9.6	161.3	5.9	53.9	
		100	117.9	179.4	12.9	135.4	4.1	56.5	112.1	181.7	12.4	139.6	4.3	56.0	109.2	184.0	11.8	143.8	4.6	55.6	
		120	136.9	168.7	15.3	116.4	3.2	58.4	131.4	171.4	14.7	121.3	3.4	57.9	128.7	174.1	14.0	126.2	3.6	57.4	
	30	60	81.1	211.1	8.2	183.2	7.6	57.8	74.2	213.0	7.8	186.3	8.0	57.6	70.7	215.0	7.5	189.5	8.4	57.4	
		80	99.9	198.6	10.6	162.6	5.5	59.2	93.4	201.1	10.1	166.6	5.8	58.9	90.2	203.5	9.7	170.5	6.2	58.6	
		100	118.6	186.1	12.9	141.9	4.2	60.5	112.6	189.1	12.4	146.8	4.5	60.2	109.6	192.0	11.8	151.6	4.8	59.9	
		120	137.4	173.6	15.3	121.3	3.3	61.9	131.8	177.1	14.7	127.0	3.5	61.5	129.0	180.6	14.0	132.7	3.8	61.2	
	40	60	82.1	221.4	8.3	193.0	7.8	60.3	74.9	223.7	8.0	196.6	8.2	60.2	71.3	226.0	7.6	200.1	8.7	60.0	
		80	100.7	207.1	10.6	170.8	5.7	61.5	94.0	210.1	10.2	175.3	6.0	61.2	90.7	213.0	9.7	179.8	6.4	61.0	
		100	119.3	192.8	13.0	148.5	4.4	62.6	113.1	196.4	12.4	154.0	4.6	62.3	110.0	200.0	11.9	159.4	4.9	62.0	
		120	137.9	178.6	15.3	126.2	3.4	63.7	132.2	182.8	14.7	132.7	3.6	63.4	129.4	187.0	14.0	139.1	3.9	63.0	
90	20	60	83.9	239.4	8.5	210.3	8.2	69.0	76.1	241.5	8.1	213.8	8.7	68.6	72.2	243.6	7.7	217.3	9.2	68.3	
		80	102.6	225.7	10.9	188.5	6.1	71.2	95.2	228.3	10.4	192.8	6.4	70.7	91.5	230.9	9.9	197.2	6.9	70.3	
		100	Operation not recommended.																		
		120	Operation not recommended.																		
	30	60	85.2	252.5	8.7	222.8	8.5	75.1	77.0	255.1	8.3	226.9	9.0	74.9	72.9	257.8	7.9	230.9	9.6	74.6	
		80	103.7	236.6	11.0	199.0	6.3	76.7	96.0	239.9	10.5	204.0	6.7	76.4	92.2	243.2	10.0	209.1	7.1	76.1	
		100	Operation not recommended.																		
		120	Operation not recommended.																		
	40	60	86.6	265.5	8.9	235.3	8.8	78.2	77.9	268.8	8.5	239.9	9.3	78.0	73.6	272.0	8.0	244.6	9.9	77.8	
		80	104.7	247.5	11.1	209.5	6.5	79.5	96.8	251.5	10.6	215.2	6.9	79.2	92.8	255.4	10.1	221.0	7.4	79.0	
		100	Operation not recommended.																		
		120	Operation not recommended.																		

Note: Operation in shaded areas require special attention to ensure adequate water temperature and flow rates are maintained. Operation outside the limits could result in lockout.

GXW120 Performance Data cont.

Cooling

Source		ELT °F	Load Flow - 20 GPM						Load Flow - 30 GPM						Load Flow - 40 GPM					
EST °F	Flow GPM		LLT °F	HC MBTUH	Power kW	HR MBTUH	EER	LST °F	LLT °F	HC MBTUH	Power kW	HR MBTUH	EER	LST °F	LLT °F	HC MBTUH	Power kW	HR MBTUH	EER	LST °F
50	20	50	35.9	140.6	6.3	162.2	22.2	66.2	40.1	147.9	6.7	170.6	22.2	67.1	42.2	155.2	7.0	179.0	22.2	67.9
		70	51.4	185.8	6.9	209.3	27.0	70.9	57.5	187.3	7.1	211.6	26.3	71.2	60.6	188.7	7.4	213.9	25.5	71.4
		90	66.9	231.1	7.4	256.4	31.2	75.6	74.9	226.7	7.6	252.6	29.8	75.3	78.9	222.3	7.8	248.8	28.6	74.9
	30	50	35.9	140.9	6.4	162.7	22.1	60.8	40.1	148.7	6.5	170.8	23.0	61.4	42.2	156.6	6.6	179.0	23.8	61.9
		70	52.3	176.9	6.8	199.9	26.1	63.3	57.8	183.7	6.8	207.1	26.8	63.8	60.5	190.6	6.9	214.2	27.5	64.3
		90	68.7	212.8	7.2	237.2	29.8	65.8	75.4	218.7	7.2	243.3	30.3	66.2	78.8	224.6	7.3	249.4	30.9	66.6
	40	50	35.9	141.2	6.4	163.1	22.0	58.2	40.0	149.6	6.3	171.0	23.8	58.6	42.1	158.0	6.1	178.9	25.8	58.9
		70	53.2	167.9	6.7	190.6	25.2	59.5	58.0	180.2	6.6	202.5	27.5	60.1	60.4	192.4	6.5	214.5	29.8	60.7
		90	70.5	194.5	6.9	218.0	28.3	60.9	76.0	210.7	6.8	234.0	30.9	61.7	78.7	226.9	6.8	250.0	33.5	62.5
70	20	50	37.0	129.7	7.9	156.5	16.5	85.7	41.0	135.6	8.3	164.0	16.3	86.4	42.9	141.5	8.8	171.4	16.2	87.1
		70	52.2	177.7	8.5	206.7	20.9	90.7	58.1	178.3	8.9	208.6	20.1	90.9	61.1	178.9	9.2	210.5	19.3	91.0
		90	67.4	225.8	9.1	256.9	24.7	95.7	75.3	221.0	9.4	253.2	23.4	95.3	79.2	216.3	9.7	249.5	22.2	95.0
	30	50	37.1	129.2	8.0	156.5	16.1	80.4	40.9	136.4	8.1	163.9	16.9	80.9	42.8	143.7	8.1	171.4	17.7	81.4
		70	53.1	169.2	8.5	198.1	20.0	83.2	58.2	177.6	8.5	206.7	20.8	83.8	60.7	186.0	8.6	215.3	21.6	84.4
		90	69.1	209.3	8.9	239.6	23.5	86.0	75.4	218.8	9.0	249.4	24.3	86.6	78.6	228.2	9.1	259.3	25.1	87.3
	40	50	37.1	128.7	8.1	156.4	15.8	77.8	40.9	137.2	7.8	163.9	17.6	78.2	42.7	145.8	7.5	171.3	19.5	78.6
		70	53.9	160.7	8.4	189.4	19.1	79.5	58.2	176.9	8.2	204.8	21.6	80.2	60.3	193.0	8.0	220.2	24.3	81.0
		90	70.7	192.8	8.7	222.3	22.2	81.1	75.6	216.5	8.6	245.7	25.3	82.3	78.0	240.2	8.4	269.0	28.5	83.5
90	20	50	38.1	118.9	9.8	152.2	12.2	105.2	41.5	128.0	9.3	159.8	13.7	106.0	43.1	137.1	8.9	167.3	15.5	106.7
		70	53.8	162.5	10.4	197.8	15.7	109.8	58.6	171.6	9.9	205.2	17.4	110.5	61.0	180.6	9.3	212.5	19.3	111.2
		90	Operation not recommended.																	
	30	50	38.3	117.5	9.8	151.0	12.0	100.1	41.8	122.9	10.0	157.2	12.3	100.5	43.6	128.4	10.2	163.3	12.5	100.9
		70	54.2	158.0	10.3	193.0	15.4	102.9	59.1	163.1	10.5	198.9	15.6	103.3	61.6	168.2	10.7	204.8	15.7	103.7
		90	Operation not recommended.																	
	40	50	38.4	116.1	9.8	149.7	11.8	97.5	41.7	124.3	9.6	157.0	13.0	97.9	43.4	132.5	9.3	164.3	14.2	98.2
		70	54.6	153.6	10.1	188.2	15.1	99.4	58.8	168.3	10.0	202.4	16.8	100.1	60.9	183.0	9.8	216.5	18.6	100.8
		90	Operation not recommended.																	
110	20	50	39.7	102.5	12.2	144.0	8.4	124.4	42.8	108.4	12.2	150.0	8.9	125.0	44.3	114.2	12.3	156.1	9.3	125.6
		70	55.6	144.0	12.8	187.5	11.3	128.8	59.9	151.6	12.9	195.5	11.8	129.6	62.0	159.2	13.0	203.5	12.3	130.3
		90	Operation not recommended.																	
	30	50	39.7	103.0	11.9	143.5	8.7	119.6	42.7	108.8	11.9	149.5	9.1	120.0	44.3	114.6	12.0	155.5	9.6	120.4
		70	55.5	145.2	12.3	187.3	11.8	122.5	59.8	152.6	12.4	195.0	12.3	123.0	62.0	160.0	12.5	202.7	12.8	123.5
		90	Operation not recommended.																	
	40	50	39.6	103.5	11.6	143.0	9.0	117.2	42.7	109.3	11.6	149.0	9.4	117.4	44.2	115.1	11.7	154.9	9.8	117.7
		70	55.4	146.4	11.9	187.0	12.3	119.3	59.8	153.6	12.0	194.5	12.8	119.7	62.0	160.7	12.1	202.0	13.3	120.1
		90	Operation not recommended.																	

Note: Operation in shaded areas require special attention to ensure adequate water temperature and flow rates are maintained. Operation outside the limits could result in lockout.

GXW180 Performance Data

Heating

Source		ELT °F	Load Flow - 30 GPM						Load Flow - 45 GPM						Load Flow - 60 GPM						
EST °F	Flow GPM		LLT °F	HC MBTUH	Power kW	HE MBTUH	COP	LST °F	LLT °F	HC MBTUH	Power kW	HE MBTUH	COP	LST °F	LLT °F	HC MBTUH	Power kW	HE MBTUH	COP	LST °F	
30	45	60	72.3	184.1	10.0	150.0	5.4	23.3	68.3	185.7	9.7	152.4	5.6	23.2	66.2	187.2	9.5	154.9	5.8	23.1	
		80	91.8	176.9	12.9	132.7	4.0	24.1	87.9	178.8	12.6	135.8	4.2	24.0	86.0	180.7	12.3	138.9	4.3	23.8	
		100	111.3	169.7	15.9	115.5	3.1	24.9	107.6	171.9	15.5	119.2	3.3	24.7	105.8	174.2	15.0	122.8	3.4	24.5	
		120	130.8	162.5	18.8	98.2	2.5	25.6	127.3	165.0	18.3	102.5	2.6	25.4	125.6	167.6	17.8	106.8	2.8	25.3	
	60	60	72.7	190.1	10.1	155.8	5.5	24.8	68.5	191.8	9.8	158.4	5.7	24.7	66.4	193.5	9.5	161.0	6.0	24.6	
		80	92.1	181.9	13.0	137.6	4.1	25.4	88.2	184.0	12.6	140.8	4.3	25.3	86.2	186.0	12.3	144.1	4.4	25.2	
		100	111.6	173.7	15.9	119.4	3.2	26.0	107.8	176.1	15.5	123.3	3.3	25.9	106.0	178.5	15.1	127.1	3.5	25.8	
		120	131.0	165.5	18.9	101.2	2.6	26.6	127.5	168.3	18.3	105.7	2.7	26.5	125.7	171.1	17.8	110.2	2.8	26.3	
50	30	60	75.1	226.4	10.6	190.4	6.3	37.3	70.2	228.5	10.3	193.4	6.5	37.1	67.7	230.5	9.9	196.5	6.8	36.9	
		80	94.5	216.8	13.5	170.7	4.7	38.6	89.7	219.2	13.1	174.4	4.9	38.4	87.4	221.5	12.7	178.1	5.1	38.1	
		100	113.8	207.2	16.5	151.0	3.7	39.9	109.3	209.9	16.0	155.3	3.8	39.6	107.1	212.6	15.5	159.7	4.0	39.4	
		120	133.2	197.6	19.4	131.3	3.0	41.2	128.9	200.6	18.8	136.3	3.1	40.9	126.8	203.6	18.3	141.3	3.3	40.6	
	45	60	75.7	236.1	10.7	199.6	6.5	41.1	70.6	238.2	10.4	202.8	6.7	41.0	68.0	240.2	10.0	205.9	7.0	40.8	
		80	95.0	225.5	13.7	178.9	4.8	42.0	90.1	227.9	13.2	182.7	5.0	41.9	87.7	230.4	12.8	186.6	5.3	41.7	
		100	114.3	214.9	16.6	158.1	3.8	43.0	109.7	217.7	16.1	162.7	4.0	42.8	107.4	220.5	15.6	167.3	4.1	42.6	
		120	133.6	204.3	19.6	137.4	3.1	43.9	129.2	207.5	19.0	142.7	3.2	43.7	127.0	210.7	18.4	147.9	3.4	43.4	
	60	60	76.4	245.8	10.8	208.9	6.7	43.0	71.0	247.9	10.5	212.1	6.9	42.9	68.3	250.0	10.1	215.4	7.2	42.8	
		80	95.6	234.2	13.8	187.1	5.0	43.8	90.5	236.7	13.4	191.1	5.2	43.6	88.0	239.2	12.9	195.1	5.4	43.5	
		100	114.8	222.6	16.8	165.3	3.9	44.5	110.0	225.5	16.3	170.1	4.1	44.3	107.6	228.5	15.7	174.8	4.3	44.2	
		120	134.1	211.0	19.8	143.5	3.1	45.2	129.5	214.4	19.1	149.0	3.3	45.0	127.3	217.8	18.5	154.6	3.4	44.8	
70	30	60	78.3	274.8	11.2	236.5	7.2	54.2	72.3	277.4	10.8	240.4	7.5	54.0	69.3	279.9	10.5	244.3	7.8	53.7	
		80	97.5	261.8	14.2	213.5	5.4	55.8	91.8	264.7	13.7	218.0	5.7	55.5	88.9	267.6	13.2	222.6	5.9	55.2	
		100	116.6	248.8	17.1	190.4	4.3	57.3	111.2	252.1	16.5	195.6	4.5	57.0	108.5	255.3	16.0	200.8	4.7	56.6	
		120	135.7	235.8	20.1	167.3	3.4	58.8	130.6	239.4	19.4	173.2	3.6	58.5	128.1	243.1	18.7	179.1	3.8	58.1	
	45	60	79.2	288.2	11.4	249.2	7.4	58.9	72.9	290.7	11.0	253.1	7.7	58.8	69.8	293.2	10.6	257.0	8.1	58.6	
		80	98.3	274.1	14.4	225.0	5.6	60.0	92.3	277.1	13.9	229.7	5.8	59.8	89.3	280.0	13.4	234.4	6.1	59.6	
		100	117.3	260.1	17.4	200.8	4.4	61.1	111.7	263.5	16.8	206.2	4.6	60.8	108.9	266.9	16.2	211.7	4.8	60.6	
		120	136.4	246.1	20.4	176.6	3.5	62.2	131.1	249.9	19.7	182.8	3.7	61.9	128.5	253.8	19.0	189.0	3.9	61.6	
	60	60	80.1	301.5	11.6	261.9	7.6	61.3	73.5	304.0	11.2	265.9	8.0	61.1	70.2	306.4	10.7	269.8	8.4	61.0	
		80	99.1	286.5	14.6	236.6	5.7	62.1	92.9	289.5	14.1	241.4	6.0	62.0	89.7	292.4	13.6	246.2	6.3	61.8	
		100	118.1	271.5	17.7	211.2	4.5	63.0	112.2	275.0	17.0	216.9	4.7	62.8	109.3	278.5	16.4	222.5	5.0	62.6	
		120	137.1	256.4	20.7	185.9	3.6	63.8	131.6	260.5	20.0	192.4	3.8	63.6	128.8	264.5	19.2	198.9	4.0	63.4	
90	30	60	81.5	323.2	11.9	282.7	8.0	71.2	74.5	326.3	11.4	287.3	8.4	70.8	71.0	329.4	11.0	292.0	8.8	70.5	
		80	100.5	306.8	14.8	256.2	6.1	72.9	93.8	310.3	14.3	261.6	6.4	72.6	90.5	313.8	13.7	267.0	6.7	72.2	
		100	Operation not recommended.																		
		120	Operation not recommended.																		
	45	60	82.7	340.2	12.1	298.8	8.2	76.7	75.3	343.2	11.6	303.5	8.6	76.5	71.5	346.2	11.2	308.1	9.1	76.3	
		80	101.5	322.8	15.1	271.2	6.3	77.9	94.5	326.3	14.5	276.6	6.6	77.7	91.0	329.7	14.0	282.1	6.9	77.5	
		100	Operation not recommended.																		
		120	Operation not recommended.																		
	60	60	83.8	357.2	12.4	315.0	8.5	79.5	76.0	360.1	11.9	319.6	8.9	79.3	72.1	362.9	11.4	324.2	9.4	79.2	
		80	102.6	338.8	15.4	286.1	6.4	80.5	95.2	342.2	14.8	291.6	6.8	80.3	91.5	345.7	14.2	297.2	7.1	80.1	
		100	Operation not recommended.																		
		120	Operation not recommended.																		

Note: Operation in shaded areas require special attention to ensure adequate water temperature and flow rates are maintained. Operation outside the limits could result in lockout.

GXW180 Performance Data cont.

Cooling

Source		ELT °F	Load Flow - 30 GPM						Load Flow - 45 GPM						Load Flow - 60 GPM					
EST °F	Flow GPM		LLT °F	HC MBTUH	Power kW	HR MBTUH	EER	LST °F	LLT °F	HC MBTUH	Power kW	HR MBTUH	EER	LST °F	LLT °F	HC MBTUH	Power kW	HR MBTUH	EER	LST °F
50	30	50	36.6	200.7	9.3	232.3	21.7	65.5	40.7	209.3	9.3	241.1	22.5	66.1	42.7	217.8	9.4	249.8	23.2	66.7
		70	52.6	260.3	10.0	294.3	26.1	69.6	58.0	271.1	10.0	305.3	27.0	70.4	60.6	281.9	10.1	316.3	28.0	71.1
		90	68.7	319.9	10.7	356.3	30.0	73.8	75.2	332.9	10.7	369.5	31.0	74.6	78.5	345.9	10.8	382.8	32.1	75.5
	45	50	36.4	204.2	9.1	235.3	22.4	60.5	40.5	213.1	9.2	244.3	23.3	60.9	42.6	222.0	9.2	253.4	24.1	61.3
		70	52.4	264.2	9.6	297.1	27.4	63.2	58.0	270.0	9.7	303.1	27.8	63.5	60.8	275.8	9.8	309.1	28.3	63.7
		90	68.4	324.2	10.2	359.0	31.8	66.0	75.5	326.9	10.2	361.9	31.9	66.1	79.0	329.6	10.3	364.7	32.0	66.2
	60	50	36.2	207.7	9.0	238.3	23.2	57.9	40.4	216.9	9.0	247.6	24.1	58.3	42.5	226.1	9.0	257.0	25.0	58.6
		70	52.1	268.2	9.3	300.0	28.7	60.0	58.0	268.9	9.4	300.9	28.7	60.0	61.0	269.6	9.4	301.8	28.6	60.1
		90	68.1	328.6	9.7	361.6	33.9	62.1	75.7	320.9	9.8	354.2	32.9	61.8	79.6	313.2	9.8	346.7	31.8	61.6
70	30	50	37.6	186.3	11.1	224.2	16.8	84.9	41.4	193.7	11.2	231.7	17.4	85.4	43.3	201.0	11.2	239.3	17.9	86.0
		70	53.0	254.6	12.1	295.7	21.1	89.7	58.5	259.8	12.2	301.3	21.4	90.1	61.2	264.9	12.3	306.8	21.6	90.5
		90	68.5	322.9	13.0	367.3	24.8	94.5	75.5	325.8	13.2	370.8	24.7	94.7	79.0	328.8	13.3	374.3	24.7	95.0
	45	50	37.4	189.6	10.8	226.6	17.5	80.1	41.2	197.1	10.9	234.3	18.1	80.4	43.2	204.7	11.0	242.1	18.7	80.8
		70	52.7	259.0	11.7	298.9	22.2	83.3	58.2	264.4	11.8	304.5	22.5	83.5	61.0	269.8	11.8	310.2	22.8	83.8
		90	68.1	328.5	12.5	371.2	26.2	86.5	75.3	331.7	12.6	374.7	26.3	86.7	78.8	334.8	12.7	378.2	26.3	86.8
	60	50	37.1	192.9	10.6	229.1	18.2	77.6	41.1	200.6	10.7	237.0	18.8	77.9	43.1	208.3	10.7	244.9	19.5	78.2
		70	52.4	263.5	11.3	302.1	23.3	80.1	58.0	269.0	11.4	307.8	23.7	80.3	60.8	274.6	11.4	313.5	24.1	80.4
		90	67.7	334.2	12.0	375.1	27.8	82.5	75.0	337.5	12.1	378.6	28.0	82.6	78.6	340.8	12.1	382.1	28.2	82.7
90	30	50	38.8	168.6	13.9	215.8	12.2	104.4	42.2	175.5	13.9	223.0	12.6	104.9	43.9	182.4	14.0	230.2	13.0	105.3
		70	54.7	229.7	14.9	280.5	15.5	108.7	59.4	237.5	15.0	288.7	15.8	109.2	61.8	245.3	15.2	297.0	16.2	109.8
		90	Operation not recommended.																	
	45	50	38.6	170.4	13.6	216.6	12.6	99.6	42.1	177.4	13.6	223.9	13.0	100.0	43.9	184.5	13.7	231.2	13.5	100.3
		70	54.5	233.0	14.4	282.3	16.1	102.5	59.3	241.0	14.5	290.6	16.6	102.9	61.7	249.0	14.7	299.0	17.0	103.3
		90	Operation not recommended.																	
	60	50	38.5	172.2	13.3	217.4	13.0	97.2	42.0	179.4	13.3	224.8	13.5	97.5	43.8	186.6	13.4	232.3	14.0	97.7
		70	54.2	236.3	14.0	284.1	16.9	99.5	59.1	244.5	14.1	292.5	17.4	99.7	61.6	252.7	14.1	300.9	17.9	100.0
		90	Operation not recommended.																	
110	30	50	39.9	150.8	16.6	207.5	9.1	123.8	43.0	157.3	16.7	214.3	9.4	124.3	44.5	163.7	16.8	221.1	9.7	124.7
		70	56.3	204.9	17.7	265.2	11.6	127.7	60.4	215.3	17.9	276.2	12.1	128.4	62.5	225.7	18.0	287.3	12.5	129.2
		90	Operation not recommended.																	
	45	50	39.9	151.1	16.3	206.6	9.3	119.2	43.0	157.7	16.3	213.5	9.6	119.5	44.5	164.3	16.4	220.4	10.0	119.8
		70	56.2	207.0	17.2	265.6	12.1	121.8	60.3	217.6	17.3	276.7	12.6	122.3	62.4	228.2	17.5	287.8	13.1	122.8
		90	Operation not recommended.																	
	60	50	39.9	151.5	15.9	205.7	9.5	116.9	43.0	158.2	16.0	212.7	9.9	117.1	44.5	164.9	16.0	219.6	10.3	117.3
		70	56.1	209.1	16.7	266.0	12.5	118.9	60.2	219.9	16.8	277.2	13.1	119.2	62.3	230.7	16.9	288.3	13.7	119.6
		90	Operation not recommended.																	

Note: Operation in shaded areas require special attention to ensure adequate water temperature and flow rates are maintained. Operation outside the limits could result in lockout.

GXW240 Performance Data

Heating

Source		ELT °F	Load Flow - 40 GPM						Load Flow - 60 GPM						Load Flow - 80 GPM						
EST °F	Flow GPM		LLT °F	HC MBTUH	Power kW	HE MBTUH	COP	LST °F	LLT °F	HC MBTUH	Power kW	HE MBTUH	COP	LST °F	LLT °F	HC MBTUH	Power kW	HE MBTUH	COP	LST °F	
30	60	60	71.8	235.1	11.9	194.6	5.8	23.5	67.9	235.6	11.6	195.9	5.9	23.5	65.9	236.1	11.4	197.3	6.1	23.4	
		80	91.1	222.3	15.9	168.1	4.1	24.4	87.5	224.4	15.9	170.2	4.1	24.3	85.7	226.5	15.9	172.3	4.2	24.3	
		100	110.5	209.5	19.9	141.6	3.1	25.3	107.1	213.2	20.2	144.4	3.1	25.2	105.4	216.9	20.4	147.3	3.1	25.1	
		120	129.8	196.7	23.9	115.1	2.4	26.2	126.7	202.0	24.4	118.7	2.4	26.0	125.2	207.3	24.9	122.2	2.4	25.9	
	80	60	72.3	246.2	11.8	205.8	6.1	24.9	68.2	246.7	11.7	206.9	6.2	24.8	66.2	247.1	11.5	207.9	6.3	24.8	
		80	91.4	227.9	15.5	175.1	4.3	25.6	87.7	232.2	15.5	179.2	4.4	25.5	85.9	236.4	15.6	183.3	4.5	25.4	
		100	110.5	209.5	19.1	144.3	3.2	26.4	107.3	217.7	19.4	151.5	3.3	26.2	105.6	225.8	19.6	158.7	3.4	26.0	
		120	129.6	191.2	22.8	113.5	2.5	27.2	126.8	203.1	23.2	123.8	2.6	26.9	125.4	215.1	23.7	134.1	2.7	26.6	
50	40	60	74.5	290.4	13.3	245.1	6.4	37.7	69.7	291.7	12.9	247.8	6.6	37.6	67.3	292.9	12.5	250.4	6.9	37.5	
		80	94.0	280.3	17.8	219.5	4.6	39.0	89.4	282.6	17.7	222.2	4.7	38.9	87.1	284.9	17.6	224.9	4.7	38.8	
		100	113.5	270.1	22.4	193.8	3.5	40.3	109.1	273.5	22.6	196.6	3.6	40.2	106.9	276.9	22.7	199.3	3.6	40.0	
		120	133.0	260.0	26.9	168.1	2.8	41.6	128.8	264.4	27.4	170.9	2.8	41.5	126.7	268.8	27.9	173.8	2.8	41.3	
	60	60	75.2	303.8	13.4	258.1	6.6	41.4	70.2	305.4	13.0	261.0	6.9	41.3	67.7	307.0	12.6	263.9	7.1	41.2	
		80	94.4	288.4	17.4	228.9	4.8	42.4	89.8	292.5	17.3	233.3	4.9	42.2	87.4	296.7	17.2	237.8	5.0	42.1	
		100	113.6	272.9	21.5	199.6	3.7	43.3	109.3	279.6	21.7	205.7	3.8	43.1	107.2	286.3	21.9	211.7	3.8	42.9	
		120	132.9	257.4	25.5	170.3	3.0	44.3	128.9	266.7	26.0	178.0	3.0	44.1	126.9	275.9	26.5	185.7	3.1	43.8	
	80	60	75.9	317.2	13.5	271.1	6.9	43.2	70.6	319.2	13.2	274.2	7.1	43.1	68.0	321.2	12.8	277.4	7.3	43.1	
		80	94.8	296.4	17.1	238.2	5.1	44.0	90.1	302.4	17.0	244.5	5.2	43.9	87.7	308.4	16.9	250.8	5.3	43.7	
		100	113.8	275.6	20.6	205.4	3.9	44.9	109.5	285.7	20.8	214.8	4.0	44.6	107.4	295.7	21.0	224.2	4.1	44.4	
		120	132.7	254.8	24.1	172.5	3.1	45.7	129.0	268.9	24.6	185.0	3.2	45.4	127.1	283.0	25.0	197.6	3.3	45.1	
70	40	60	77.8	356.9	14.6	306.9	7.1	54.7	72.0	358.9	14.1	310.6	7.4	54.5	69.0	360.8	13.6	314.3	7.7	54.3	
		80	97.2	343.8	19.4	277.8	5.2	56.1	91.6	348.5	19.2	283.2	5.3	55.8	88.8	353.3	19.0	288.6	5.5	55.6	
		100	116.5	330.8	24.1	248.6	4.0	57.6	111.3	338.2	24.2	255.8	4.1	57.2	108.6	345.7	24.3	262.9	4.2	56.9	
		120	135.9	317.8	28.8	219.5	3.2	59.0	130.9	327.9	29.2	228.3	3.3	58.6	128.5	338.1	29.6	237.2	3.4	58.1	
	60	60	78.6	372.6	14.9	321.7	7.3	59.3	72.5	375.3	14.4	326.1	7.6	59.1	69.5	378.0	13.9	330.6	8.0	59.0	
		80	97.7	354.4	19.0	289.6	5.5	60.3	92.0	360.6	18.8	296.5	5.6	60.1	89.2	366.9	18.6	303.4	5.8	59.9	
		100	116.8	336.2	23.1	257.5	4.3	61.4	111.5	346.0	23.2	266.9	4.4	61.1	108.9	355.7	23.3	276.2	4.5	60.8	
		120	135.9	318.1	27.1	225.5	3.4	62.5	131.0	331.3	27.6	237.3	3.5	62.1	128.6	344.5	28.0	249.1	3.6	61.7	
	80	60	79.4	388.2	15.2	336.4	7.5	61.6	73.1	391.7	14.7	341.6	7.8	61.5	69.9	395.2	14.2	346.9	8.2	61.3	
		80	98.2	365.0	18.6	301.4	5.7	62.5	92.4	372.7	18.4	309.8	5.9	62.3	89.5	380.4	18.2	318.2	6.1	62.0	
		100	117.1	341.7	22.1	266.5	4.5	63.3	111.8	353.7	22.2	278.0	4.7	63.0	109.1	365.7	22.3	289.6	4.8	62.8	
		120	135.9	318.4	25.5	231.5	3.7	64.2	131.2	334.7	25.9	246.2	3.8	63.8	128.8	351.0	26.4	261.0	3.9	63.5	
90	40	60	81.2	423.3	16.0	368.7	7.8	71.6	74.2	426.0	15.4	373.4	8.1	71.3	70.7	428.8	14.8	378.1	8.5	71.1	
		80	100.4	407.4	20.9	336.1	5.7	73.2	93.8	414.5	20.6	344.2	5.9	72.8	90.5	421.6	20.3	352.3	6.1	72.4	
		100	Operation not recommended.																		
		120	Operation not recommended.																		
	60	60	82.1	441.3	16.4	385.2	7.9	77.2	74.8	445.1	15.8	391.2	8.3	77.0	71.2	449.0	15.2	397.2	8.7	76.8	
		80	101.0	420.4	20.5	350.4	6.0	78.3	94.3	428.7	20.2	359.7	6.2	78.0	90.9	437.0	19.9	369.0	6.4	77.7	
		100	Operation not recommended.																		
		120	Operation not recommended.																		
	80	60	83.0	459.3	16.9	401.6	8.0	80.0	75.5	464.2	16.2	409.0	8.4	79.8	71.7	469.2	15.5	416.3	8.9	79.6	
		80	101.7	433.5	20.2	364.6	6.3	80.9	94.8	443.0	19.9	375.1	6.5	80.6	91.3	452.4	19.6	385.7	6.8	80.4	
		100	Operation not recommended.																		
		120	Operation not recommended.																		

Note: Operation in shaded areas require special attention to ensure adequate water temperature and flow rates are maintained. Operation outside the limits could result in lockout.

GXW240 Performance Data cont.

Cooling

Source		ELT °F	Load Flow - 40 GPM						Load Flow - 60 GPM						Load Flow - 80 GPM					
EST °F	Flow GPM		LLT °F	HC MBTUH	Power kW	HR MBTUH	EER	LST °F	LLT °F	HC MBTUH	Power kW	HR MBTUH	EER	LST °F	LLT °F	HC MBTUH	Power kW	HR MBTUH	EER	LST °F
50	40	50	36.5	269.5	11.8	309.8	22.8	65.5	40.5	283.7	12.0	324.7	23.6	66.2	42.6	298.0	12.2	339.6	24.4	67.0
		70	53.3	334.7	12.9	378.8	25.9	68.9	58.6	343.4	13.1	388.1	26.2	69.4	61.2	352.1	13.3	397.4	26.6	69.9
		90	70.0	400.0	14.0	447.8	28.5	72.4	76.6	403.1	14.2	451.5	28.5	72.6	79.8	406.3	14.3	455.1	28.4	72.8
	60	50	36.5	269.6	11.6	309.2	23.2	60.3	40.6	283.4	11.8	323.6	24.0	60.8	42.6	297.2	12.0	338.1	24.8	61.3
		70	53.7	326.3	12.5	369.0	26.0	62.3	58.9	334.5	12.7	377.8	26.3	62.6	61.4	342.7	12.9	386.7	26.6	62.9
		90	70.9	383.0	13.5	428.9	28.5	64.3	77.1	385.6	13.6	432.1	28.3	64.4	80.3	388.2	13.8	435.2	28.2	64.5
	80	50	36.5	269.7	11.4	308.5	23.7	57.7	40.6	283.0	11.6	322.6	24.4	58.1	42.6	296.4	11.8	336.6	25.1	58.4
		70	54.1	317.8	12.1	359.2	26.2	59.0	59.1	325.6	12.3	367.6	26.4	59.2	61.7	333.3	12.5	376.0	26.7	59.4
		90	71.7	366.0	12.9	410.0	28.4	60.2	77.7	368.1	13.1	412.6	28.2	60.3	80.7	370.2	13.2	415.3	28.0	60.4
70	40	50	37.8	244.9	15.0	296.1	16.3	84.8	41.4	257.3	15.2	309.1	17.0	85.5	43.3	269.6	15.3	322.0	17.6	86.1
		70	54.2	315.3	16.2	370.6	19.4	88.5	59.2	324.9	16.4	381.0	19.8	89.1	61.6	334.5	16.7	391.4	20.1	89.6
		90	70.7	385.7	17.4	445.2	22.1	92.3	76.9	392.5	17.7	452.9	22.2	92.6	80.0	399.3	18.0	460.7	22.2	93.0
	60	50	37.7	245.1	14.7	295.1	16.7	79.8	41.4	257.1	14.9	307.8	17.3	80.3	43.3	269.2	15.0	320.5	17.9	80.7
		70	54.5	310.6	15.7	364.2	19.8	82.1	59.3	319.9	15.9	374.2	20.1	82.5	61.8	329.2	16.2	384.3	20.4	82.8
		90	71.2	376.0	16.7	433.2	22.5	84.4	77.2	382.6	17.0	440.6	22.5	84.7	80.3	389.1	17.3	448.1	22.5	84.9
	80	50	37.7	245.2	14.3	294.1	17.1	77.4	41.4	257.0	14.5	306.6	17.7	77.7	43.3	268.8	14.7	319.0	18.3	78.0
		70	54.7	305.8	15.2	357.7	20.1	78.9	59.5	314.8	15.4	367.4	20.4	79.2	61.9	323.8	15.6	377.2	20.7	79.4
		90	71.7	366.3	16.1	421.2	22.8	80.5	77.6	372.6	16.3	428.3	22.8	80.7	80.5	378.8	16.6	435.4	22.9	80.9
90	40	50	39.0	220.4	18.2	282.4	12.1	104.1	42.3	230.8	18.3	293.4	12.6	104.7	44.0	241.3	18.5	304.4	13.0	105.2
		70	55.2	295.9	19.5	362.5	15.2	108.1	59.8	306.4	19.8	373.9	15.5	108.7	62.1	316.8	20.1	385.4	15.8	109.3
		90	Operation not recommended.																	
	60	50	39.0	220.6	17.7	281.1	12.4	99.4	42.3	230.9	17.9	292.0	12.9	99.7	44.0	241.3	18.1	302.9	13.4	100.1
		70	55.3	294.8	18.9	359.3	15.6	102.0	59.8	305.2	19.2	370.6	15.9	102.4	62.1	315.6	19.4	381.9	16.2	102.7
		90	Operation not recommended.																	
	80	50	39.0	220.8	17.3	279.8	12.8	97.0	42.3	231.0	17.5	290.6	13.2	97.3	44.0	241.2	17.6	301.4	13.7	97.5
		70	55.3	293.7	18.3	356.1	16.1	98.9	59.9	304.0	18.5	367.3	16.4	99.2	62.1	314.3	18.8	378.4	16.7	99.5
		90	Operation not recommended.																	
110	40	50	40.2	195.8	21.4	268.7	9.2	123.4	43.2	204.4	21.5	277.8	9.5	123.9	44.7	212.9	21.7	286.8	9.8	124.3
		70	56.2	276.5	22.8	354.3	12.1	127.7	60.4	287.9	23.1	366.8	12.4	128.3	62.5	299.2	23.5	379.4	12.7	129.0
		90	Operation not recommended.																	
	60	50	40.2	196.1	20.8	267.1	9.4	118.9	43.2	204.7	21.0	276.2	9.8	119.2	44.7	213.3	21.1	285.3	10.1	119.5
		70	56.0	279.1	22.1	354.4	12.6	121.8	60.3	290.6	22.4	367.0	13.0	122.2	62.4	302.0	22.7	379.5	13.3	122.7
		90	Operation not recommended.																	
	80	50	40.2	196.3	20.3	265.4	9.7	116.6	43.2	205.0	20.4	274.6	10.0	116.9	44.7	213.6	20.5	283.7	10.4	117.1
		70	55.9	281.7	21.3	354.5	13.2	118.9	60.2	293.3	21.6	367.1	13.6	119.2	62.4	304.9	21.9	379.6	13.9	119.5
		90	Operation not recommended.																	

Note: Operation in shaded areas require special attention to ensure adequate water temperature and flow rates are maintained. Operation outside the limits could result in lockout.

4/29/14

GXW360 Performance Data

Heating

Source		ELT °F	Load Flow - 60 GPM						Load Flow - 90 GPM						Load Flow - 120 GPM						
EST °F	Flow GPM		LLT °F	HC MBTUH	Power kW	HE MBTUH	COP	LST °F	LLT °F	HC MBTUH	Power kW	HE MBTUH	COP	LST °F	LLT °F	HC MBTUH	Power kW	HE MBTUH	COP	LST °F	
30	90	60	72.1	364.4	19.0	299.8	5.6	23.3	68.1	365.7	18.6	302.3	5.8	23.3	66.1	366.9	18.2	304.9	5.9	23.2	
		80	91.7	349.7	24.8	265.3	4.1	24.1	87.8	351.2	24.2	268.5	4.2	24.0	85.9	352.7	23.7	271.8	4.4	24.0	
		100	111.2	335.0	30.6	230.7	3.2	24.9	107.5	336.8	29.9	234.8	3.3	24.8	105.6	338.5	29.2	238.8	3.4	24.7	
		120	130.7	320.3	36.4	196.2	2.6	25.6	127.2	322.3	35.6	201.0	2.7	25.5	125.4	324.3	34.8	205.7	2.7	25.4	
	120	60	72.6	377.7	19.1	312.4	5.8	24.8	68.4	379.1	18.7	315.2	5.9	24.7	66.3	380.6	18.3	318.0	6.1	24.7	
		80	92.0	361.0	24.9	276.0	4.2	25.4	88.1	362.8	24.4	279.6	4.4	25.3	86.1	364.5	23.8	283.2	4.5	25.3	
		100	111.5	344.3	30.7	239.6	3.3	26.0	107.7	346.4	30.0	244.0	3.4	25.9	105.8	348.4	29.3	248.4	3.5	25.9	
		120	130.9	327.6	36.5	203.2	2.6	26.6	127.3	330.0	35.6	208.4	2.7	26.5	125.5	332.4	34.8	213.6	2.8	26.4	
50	60	60	75.2	455.3	20.5	385.4	6.5	37.2	70.1	452.9	20.0	384.7	6.6	37.2	67.5	450.5	19.5	383.9	6.8	37.2	
		80	94.3	428.7	26.3	338.9	4.8	38.7	89.5	428.5	25.7	340.9	4.9	38.6	87.1	428.3	25.0	342.9	5.0	38.6	
		100	113.4	402.1	32.1	292.5	3.7	40.3	109.0	404.1	31.3	297.2	3.8	40.1	106.8	406.0	30.5	301.9	3.9	39.9	
		120	132.5	375.5	38.0	246.0	2.9	41.8	128.4	379.6	37.0	253.5	3.0	41.6	126.4	383.7	36.0	261.0	3.1	41.3	
	90	60	75.6	467.2	20.7	396.7	6.6	41.2	70.3	464.6	20.2	395.8	6.7	41.2	67.7	462.1	19.7	394.9	6.9	41.2	
		80	94.6	439.3	26.5	349.0	4.9	42.2	89.8	439.2	25.8	351.1	5.0	42.2	87.3	439.2	25.2	353.3	5.1	42.1	
		100	113.7	411.4	32.3	301.2	3.7	43.3	109.2	413.8	31.5	306.5	3.9	43.2	106.9	416.3	30.6	311.7	4.0	43.1	
		120	132.8	383.5	38.1	253.5	2.9	44.4	128.6	388.5	37.1	261.8	3.1	44.2	126.6	393.4	36.1	270.2	3.2	44.0	
	120	60	76.0	479.1	20.8	408.0	6.7	43.2	70.6	476.3	20.3	406.9	6.9	43.2	67.9	473.6	19.8	405.9	7.0	43.2	
		80	95.0	449.9	26.6	359.0	5.0	44.0	90.0	450.0	26.0	361.4	5.1	44.0	87.5	450.1	25.3	363.7	5.2	43.9	
		100	114.0	420.7	32.4	310.0	3.8	44.8	109.4	423.6	31.6	315.8	3.9	44.7	107.1	426.5	30.8	321.5	4.1	44.6	
		120	133.1	391.5	38.2	261.0	3.0	45.6	128.8	397.3	37.2	270.2	3.1	45.5	126.7	403.0	36.2	279.4	3.3	45.3	
70	60	60	78.6	559.5	22.2	483.8	7.4	53.9	72.3	553.7	21.6	479.9	7.5	54.0	69.1	547.9	21.1	475.9	7.6	54.1	
		80	97.3	519.0	28.0	423.4	5.4	55.9	91.5	517.3	27.2	424.4	5.6	55.9	88.6	515.6	26.5	425.3	5.7	55.8	
		100	115.9	478.5	33.8	363.1	4.1	57.9	110.7	480.9	32.8	368.9	4.3	57.7	108.1	483.4	31.9	374.7	4.4	57.5	
		120	134.6	438.0	39.6	302.7	3.2	59.9	129.9	444.6	38.5	313.4	3.4	59.6	127.5	451.2	37.3	324.0	3.5	59.2	
	90	60	79.0	570.0	22.4	493.7	7.5	59.0	72.5	563.6	21.8	489.3	7.6	59.1	69.3	557.2	21.2	484.8	7.7	59.2	
		80	97.6	528.9	28.2	432.7	5.5	60.4	91.7	527.3	27.4	433.7	5.6	60.4	88.8	525.6	26.6	434.8	5.8	60.3	
		100	116.3	487.8	34.0	371.8	4.2	61.7	110.9	490.9	33.0	378.2	4.4	61.6	108.2	494.0	32.0	384.7	4.5	61.5	
		120	134.9	446.7	39.8	310.8	3.3	63.1	130.1	454.6	38.6	322.7	3.4	62.8	127.7	462.4	37.5	334.6	3.6	62.6	
	120	60	79.3	580.5	22.5	503.6	7.5	61.6	72.7	573.5	22.0	498.6	7.7	61.7	69.4	566.6	21.4	493.7	7.8	61.8	
		80	98.0	538.8	28.4	442.0	5.6	62.6	91.9	537.2	27.6	443.1	5.7	62.6	88.9	535.6	26.8	444.2	5.9	62.6	
		100	116.6	497.1	34.2	380.4	4.3	63.7	111.1	500.9	33.2	387.6	4.4	63.5	108.4	504.6	32.2	394.7	4.6	63.4	
		120	135.2	455.5	40.0	318.8	3.3	64.7	130.3	464.6	38.8	332.0	3.5	64.5	127.9	473.7	37.6	345.2	3.7	64.2	
90	60	60	82.1	663.6	23.9	582.1	8.1	70.6	74.5	654.4	23.3	575.1	8.2	70.8	70.8	645.2	22.6	568.0	8.4	71.1	
		80	100.3	609.2	29.7	507.9	6.0	73.1	93.5	606.1	28.8	507.8	6.2	73.1	90.1	603.0	27.9	507.7	6.3	73.1	
		100	Operation not recommended.																		
		120	Operation not recommended.																		
	90	60	82.4	672.8	24.1	590.7	8.2	76.9	74.7	662.6	23.4	582.7	8.3	77.1	70.9	652.4	22.7	574.8	8.4	77.2	
		80	100.6	618.5	29.9	516.5	6.1	78.5	93.7	615.3	29.0	516.3	6.2	78.5	90.2	612.1	28.1	516.2	6.4	78.5	
		100	Operation not recommended.																		
		120	Operation not recommended.																		
	120	60	82.7	681.9	24.2	599.2	8.2	80.0	74.9	670.7	23.6	590.3	8.3	80.2	71.0	659.6	22.9	581.5	8.4	80.3	
		80	100.9	627.7	30.1	525.0	6.1	81.3	93.9	624.4	29.2	524.8	6.3	81.3	90.4	621.2	28.3	524.7	6.4	81.3	
		100	Operation not recommended.																		
		120	Operation not recommended.																		

Note: Operation in shaded areas require special attention to ensure adequate water temperature and flow rates are maintained. Operation outside the limits could result in lockout.

GXW360 Performance Data cont.

Cooling

Source		ELT °F	Load Flow - 60 GPM						Load Flow - 90 GPM						Load Flow - 120 GPM					
EST °F	Flow GPM		LLT °F	HC MBTUH	Power kW	HR MBTUH	EER	LST °F	LLT °F	HC MBTUH	Power kW	HR MBTUH	EER	LST °F	LLT °F	HC MBTUH	Power kW	HR MBTUH	EER	LST °F
50	60	50	37.2	384.9	18.3	447.4	21.0	64.9	41.0	404.2	18.7	467.8	21.7	65.6	42.9	423.4	19.0	488.3	22.3	66.3
		70	53.4	498.4	20.2	567.2	24.7	68.9	58.6	511.7	20.5	581.5	25.0	69.4	61.2	525.0	20.8	595.9	25.3	69.9
		90	69.6	611.9	22.0	686.9	27.8	72.9	76.2	619.3	22.3	695.2	27.8	73.2	79.6	626.6	22.6	703.6	27.8	73.5
	90	50	37.2	383.2	18.0	444.5	21.3	59.9	41.1	402.7	18.3	465.1	22.0	60.3	43.0	422.3	18.6	485.8	22.7	60.8
		70	54.0	481.4	19.5	548.0	24.7	62.2	59.0	494.7	19.7	562.1	25.1	62.5	61.5	508.0	20.0	576.2	25.4	62.8
		90	70.7	579.7	21.1	651.6	27.5	64.5	77.0	586.7	21.2	659.1	27.7	64.6	80.1	593.8	21.3	666.6	27.8	64.8
	120	50	37.3	381.5	17.6	441.6	21.7	57.4	41.1	401.3	17.9	462.5	22.4	57.7	43.0	421.1	18.2	483.3	23.1	58.1
		70	54.5	464.5	18.9	528.9	24.6	58.8	59.4	477.8	19.0	542.7	25.1	59.0	61.8	491.1	19.2	556.4	25.6	59.3
		90	71.8	547.5	20.1	616.2	27.2	60.3	77.7	554.2	20.1	622.9	27.5	60.4	80.6	561.0	20.1	629.6	27.9	60.5
70	60	50	38.2	353.3	22.7	430.8	15.6	84.4	41.8	371.0	23.0	449.5	16.1	85.0	43.5	388.7	23.3	468.3	16.7	85.6
		70	54.5	465.8	24.7	550.0	18.9	88.3	59.3	481.4	25.0	566.7	19.2	88.9	61.7	497.0	25.4	583.5	19.6	89.4
		90	70.7	578.3	26.7	669.2	21.7	92.3	76.9	591.7	27.0	684.0	21.9	92.8	79.9	605.2	27.4	698.7	22.1	93.3
	90	50	38.3	352.1	22.2	428.0	15.8	79.5	41.8	370.0	22.5	446.8	16.4	79.9	43.5	387.8	22.8	465.7	17.0	80.3
		70	54.8	455.3	24.0	537.0	19.0	81.9	59.6	470.2	24.2	552.9	19.4	82.3	61.9	485.1	24.5	568.7	19.8	82.6
		90	71.4	558.5	25.7	646.1	21.8	84.4	77.3	570.5	25.9	658.9	22.0	84.6	80.3	582.4	26.2	671.7	22.3	84.9
	120	50	38.3	350.8	21.8	425.2	16.1	77.1	41.8	368.9	22.1	444.2	16.7	77.4	43.6	387.0	22.3	463.1	17.3	77.7
		70	55.2	444.8	23.2	524.1	19.1	78.7	59.8	459.0	23.4	539.0	19.6	79.0	62.1	473.3	23.6	553.9	20.0	79.2
		90	72.0	538.7	24.7	622.9	21.8	80.4	77.8	549.2	24.8	633.8	22.1	80.6	80.7	559.7	24.9	644.7	22.5	80.7
90	60	50	39.3	321.7	27.1	414.1	11.9	103.8	42.5	337.9	27.3	431.2	12.4	104.4	44.1	354.1	27.6	448.3	12.8	104.9
		70	55.6	433.2	29.2	532.8	14.8	107.8	60.0	451.0	29.6	551.9	15.3	108.4	62.2	468.9	29.9	571.1	15.7	109.0
		90	Operation not recommended.																	
	90	50	39.3	320.9	26.5	411.5	12.1	99.1	42.5	337.2	26.8	428.5	12.6	99.5	44.1	353.4	27.0	445.6	13.1	99.9
		70	55.7	429.1	28.4	526.0	15.1	101.7	60.1	445.7	28.7	543.6	15.5	102.1	62.3	462.2	29.0	561.2	15.9	102.5
		90	Operation not recommended.																	
	120	50	39.3	320.1	26.0	408.8	12.3	96.8	42.5	336.5	26.2	425.9	12.8	97.1	44.1	352.8	26.4	442.9	13.3	97.4
		70	55.8	425.1	27.6	519.2	15.4	98.7	60.2	440.3	27.8	535.3	15.8	98.9	62.4	455.6	28.1	551.3	16.2	99.2
		90	Operation not recommended.																	
110	60	50	40.3	290.2	31.5	397.5	9.2	123.2	43.2	304.8	31.7	412.9	9.6	123.8	44.7	319.4	31.9	428.3	10.0	124.3
		70	56.6	400.6	33.7	515.6	11.9	127.2	60.7	420.7	34.1	537.2	12.3	127.9	62.7	440.8	34.5	558.7	12.8	128.6
		90	Operation not recommended.																	
	90	50	40.3	289.8	30.8	394.9	9.4	118.8	43.2	304.4	31.0	410.2	9.8	119.1	44.7	319.0	31.2	425.5	10.2	119.5
		70	56.6	402.9	32.8	515.0	12.3	121.4	60.6	421.1	33.2	534.4	12.7	121.9	62.7	439.3	33.5	553.7	13.1	122.3
		90	Operation not recommended.																	
	120	50	40.4	289.5	30.2	392.4	9.6	116.5	43.2	304.0	30.3	407.6	10.0	116.8	44.7	318.6	30.5	422.7	10.4	117.0
		70	56.5	405.3	32.0	514.4	12.7	118.6	60.6	421.6	32.2	531.6	13.1	118.9	62.7	437.8	32.5	548.8	13.5	119.1
		90	Operation not recommended.																	

Note: Operation in shaded areas require special attention to ensure adequate water temperature and flow rates are maintained. Operation outside the limits could result in lockout.

GXW600 Performance Data

Heating

Source		ELT °F	Load Flow - 100 GPM					Load Flow - 150 GPM					Load Flow - 200 GPM							
EST °F	Flow GPM		LLT °F	HC MBTUH	Power kW	HE MBTUH	COP	LST °F	LLT °F	HC MBTUH	Power kW	HE MBTUH	COP	LST °F	LLT °F	HC MBTUH	Power kW	HE MBTUH	COP	LST °F
30	150	60	71.3	562.9	30.1	460.3	5.5	23.9	67.6	566.3	29.0	467.5	5.7	23.8	65.7	569.7	27.8	474.6	6.0	23.7
		80	90.6	528.0	38.4	397.0	4.0	24.7	87.0	524.4	36.8	398.8	4.2	24.7	85.2	520.8	35.3	400.5	4.3	24.7
		100	109.9	493.1	46.7	333.8	3.1	25.5	106.4	482.6	44.7	330.1	3.2	25.6	104.7	472.0	42.7	326.4	3.2	25.6
		120	129.2	458.2	55.0	270.5	2.4	26.4	125.9	440.7	52.5	261.4	2.5	26.5	124.2	423.2	50.1	252.3	2.5	26.6
	200	60	71.8	591.7	31.1	485.7	5.6	25.1	68.0	597.2	30.0	495.0	5.8	25.1	66.0	602.8	28.9	504.2	6.1	25.0
		80	91.0	551.4	39.2	417.7	4.1	25.8	87.3	545.8	37.5	417.8	4.3	25.8	85.4	540.2	35.9	417.8	4.4	25.8
		100	110.2	511.1	47.3	349.7	3.2	26.5	106.6	494.4	45.1	340.6	3.2	26.6	104.8	477.7	42.9	331.4	3.3	26.7
		120	129.4	470.8	55.4	281.7	2.5	27.2	125.9	443.0	52.6	263.3	2.5	27.4	124.2	415.1	49.9	245.0	2.4	27.6
50	100	60	73.4	667.5	33.0	555.0	5.9	38.9	69.1	684.7	32.3	574.6	6.2	38.5	67.0	701.9	31.6	594.2	6.5	38.1
		80	92.8	639.5	41.5	497.9	4.5	40.0	88.7	650.9	40.2	513.6	4.7	39.7	86.6	662.3	39.0	529.3	5.0	39.4
		100	112.2	611.5	50.0	440.8	3.6	41.2	108.2	617.1	48.2	452.6	3.8	40.9	106.2	622.6	46.4	464.4	3.9	40.7
		120	131.7	583.5	58.5	383.7	2.9	42.3	127.8	583.2	56.2	391.6	3.0	42.2	125.8	583.0	53.8	399.5	3.2	42.0
	150	60	74.0	698.5	34.1	582.0	6.0	42.2	69.9	739.7	34.0	623.7	6.4	41.7	67.8	780.9	33.9	665.3	6.8	41.1
		80	93.3	665.5	42.5	520.4	4.6	43.1	89.2	691.2	41.5	549.7	4.9	42.7	87.2	717.0	40.5	578.9	5.2	42.3
		100	112.6	632.5	50.9	458.8	3.6	43.9	108.6	642.8	49.0	475.6	3.8	43.7	106.5	653.2	47.1	492.5	4.1	43.4
		120	132.0	599.5	59.3	397.2	3.0	44.7	127.9	594.4	56.5	401.6	3.1	44.6	125.9	589.3	53.7	406.0	3.2	44.6
	200	60	74.6	729.4	35.2	609.1	6.1	43.9	70.6	794.6	35.7	672.8	6.5	43.3	68.6	859.8	36.2	736.4	7.0	42.6
		80	93.8	691.4	43.5	542.9	4.7	44.6	89.8	731.6	42.8	585.7	5.0	44.1	87.7	771.8	42.0	628.5	5.4	43.7
		100	113.1	653.4	51.8	476.8	3.7	45.2	108.9	668.6	49.8	498.6	3.9	45.0	106.8	683.7	47.8	520.5	4.2	44.8
		120	132.3	615.4	60.0	410.6	3.0	45.9	128.1	605.6	56.9	411.6	3.1	45.9	126.0	595.7	53.7	412.6	3.3	45.9
70	100	60	76.0	800.9	36.9	675.0	6.4	56.5	71.1	834.1	36.6	709.2	6.7	55.8	68.7	867.3	36.3	743.3	7.0	55.1
		80	95.5	774.4	45.4	619.4	5.0	57.6	90.7	798.8	44.4	647.4	5.3	57.1	88.2	823.1	43.3	675.3	5.6	56.5
		100	115.0	747.9	53.9	563.8	4.1	58.7	110.2	763.4	52.1	585.6	4.3	58.3	107.8	778.9	50.3	607.3	4.5	57.9
		120	134.4	721.3	62.5	508.2	3.4	59.8	129.7	728.0	59.9	523.8	3.6	59.5	127.3	734.7	57.3	539.3	3.8	59.2
	150	60	76.7	834.0	38.2	703.8	6.4	60.6	72.2	913.0	39.0	779.9	6.9	59.6	69.9	992.1	39.9	856.0	7.3	58.6
		80	96.1	802.9	46.6	643.8	5.0	61.4	91.4	858.1	46.2	700.5	5.4	60.7	89.1	913.2	45.7	757.2	5.9	59.9
		100	115.4	771.8	55.1	583.8	4.1	62.2	110.7	803.1	53.3	621.2	4.4	61.7	108.3	834.3	51.5	658.5	4.7	61.2
		120	134.8	740.7	63.6	523.8	3.4	63.0	130.0	748.1	60.5	541.8	3.6	62.8	127.6	755.4	57.4	559.7	3.9	62.5
	200	60	77.3	867.1	39.4	732.5	6.4	62.7	73.2	992.0	41.4	850.6	7.0	61.5	71.2	1116.8	43.4	968.6	7.5	60.3
		80	96.6	831.4	47.8	668.2	5.1	63.3	92.2	917.4	48.0	753.7	5.6	62.5	90.0	1003.3	48.1	839.1	6.1	61.6
		100	115.9	795.7	56.2	603.8	4.1	64.0	111.2	842.7	54.5	656.7	4.5	63.4	108.9	889.7	52.8	709.6	4.9	62.9
		120	135.2	760.0	64.6	539.5	3.4	64.6	130.2	768.1	61.1	559.8	3.7	64.4	127.8	776.2	57.5	580.1	4.0	64.2
90	100	60	78.7	934.3	40.8	795.1	6.7	74.1	73.1	983.5	41.0	843.8	7.0	73.1	70.3	1032.7	41.1	892.4	7.4	72.2
		80	98.2	909.3	49.3	741.0	5.4	75.2	92.6	946.6	48.5	781.2	5.7	74.4	89.8	984.0	47.7	821.3	6.1	73.6
		100	117.7	884.3	57.9	686.8	4.5	76.3	112.1	909.7	56.0	718.6	4.8	75.6	109.4	935.2	54.2	750.3	5.1	75.0
		120	Operation not recommended.																	
	150	60	79.4	969.6	42.2	825.5	6.7	79.0	74.5	1086.4	44.1	936.1	7.2	77.5	72.0	1203.3	45.9	1046.6	7.7	76.0
		80	98.8	940.4	50.7	767.2	5.4	79.8	93.7	1024.9	50.8	851.4	5.9	78.6	91.1	1109.4	50.9	935.6	6.4	77.5
		100	118.2	911.1	59.3	708.9	4.5	80.5	112.8	963.3	57.6	766.7	4.9	79.8	110.2	1015.5	56.0	824.5	5.3	79.0
		120	Operation not recommended.																	
	200	60	80.1	1004.8	43.6	855.9	6.7	81.4	75.9	1189.3	47.2	1028.4	7.4	79.7	73.7	1373.9	50.7	1200.8	7.9	78.0
		80	99.4	971.4	52.2	793.4	5.5	82.1	94.7	1103.1	53.2	921.6	6.1	80.8	92.3	1234.8	54.2	1049.8	6.7	79.5
		100	118.8	938.0	60.7	730.9	4.5	82.7	113.6	1016.9	59.2	814.8	5.0	81.9	111.0	1095.8	57.7	898.7	5.6	81.0
		120	Operation not recommended.																	

Note: Operation in shaded areas require special attention to ensure adequate water temperature and flow rates are maintained. Operation outside the limits could result in lockout.

GXW600 Performance Data cont.

Cooling

Source		ELT °F	Load Flow - 100 GPM						Load Flow - 150 GPM						Load Flow - 200 GPM					
EST °F	Flow GPM		LLT °F	HC MBTUH	Power kW	HR MBTUH	EER	LST °F	LLT °F	HC MBTUH	Power kW	HR MBTUH	EER	LST °F	LLT °F	HC MBTUH	Power kW	HR MBTUH	EER	LST °F
50	100	50	37.6	620.8	29.71	722.1	20.9	64.4	40.9	681.1	31.0	786.7	22.0	65.7	42.6	741.5	32.2	851.3	23.0	67.0
		70	54.0	798.2	33.04	910.9	24.2	68.2	58.8	843.4	34.3	960.3	24.6	69.2	61.1	888.6	35.5	1009.7	25.0	70.2
		90	70.5	975.6	36.38	1099.7	26.8	72.0	76.6	1005.6	37.6	1133.9	26.7	72.7	79.6	1035.7	38.8	1168.2	26.7	73.4
	150	50	37.6	619.0	28.95	717.8	21.4	59.6	41.0	677.1	30.46	781.0	22.2	60.4	42.6	735.2	32.0	844.3	23.0	61.3
		70	54.5	775.9	31.53	883.5	24.6	61.8	59.2	811.3	33.0	923.9	24.6	62.3	61.5	846.8	34.4	964.3	24.6	62.9
		90	71.3	932.8	34.11	1049.2	27.3	64.0	77.4	945.5	35.5	1066.7	26.6	64.2	80.4	958.3	36.9	1084.2	26.0	64.5
	200	50	37.7	617.3	28.19	713.5	21.9	57.1	41.0	673.1	30.0	775.4	22.5	57.8	42.7	729.0	31.7	837.2	23.0	58.4
		70	54.9	753.6	30.02	856.0	25.1	58.6	59.6	779.3	31.7	887.4	24.6	58.9	62.0	805.0	33.4	918.8	24.1	59.2
		90	72.2	889.9	31.84	998.6	27.9	60.0	78.2	885.5	33.4	999.4	26.5	60.0	81.2	881.0	35.0	1000.3	25.2	60.0
70	100	50	38.7	567.2	37.20	694.1	15.2	83.9	41.8	615.8	38.3	746.4	16.1	84.9	43.4	664.4	39.4	798.7	16.9	86.0
		70	55.2	737.5	40.45	875.5	18.2	87.5	59.6	781.7	41.7	923.9	18.8	88.5	61.7	825.9	42.9	972.3	19.3	89.4
		90	71.8	907.9	43.69	1057.0	20.8	91.1	77.4	947.7	45.1	1101.4	21.0	92.0	80.1	987.5	46.4	1145.9	21.3	92.9
	150	50	38.7	566.6	36.06	689.7	15.7	79.2	41.8	614.5	37.2	741.5	16.5	79.9	43.4	662.3	38.4	793.4	17.2	80.6
		70	55.5	725.6	38.61	857.4	18.8	81.4	59.8	765.0	39.9	901.2	19.2	82.0	62.0	804.3	41.2	944.9	19.5	82.6
		90	72.3	884.6	41.16	1025.1	21.5	83.7	77.8	915.5	42.6	1060.8	21.5	84.1	80.5	946.3	44.0	1096.5	21.5	84.6
	200	50	38.7	566.1	34.92	685.2	16.2	76.9	41.8	613.1	36.2	736.7	16.9	77.4	43.4	660.2	37.5	788.1	17.6	77.9
		70	55.7	713.7	36.78	839.2	19.4	78.4	60.0	748.2	38.2	878.4	19.6	78.8	62.2	782.7	39.5	917.6	19.8	79.2
		90	72.8	861.4	38.64	993.2	22.3	79.9	78.2	883.3	40.1	1020.2	22.0	80.2	80.9	905.2	41.6	1047.1	21.8	80.5
90	100	50	39.7	513.6	44.69	666.0	11.5	103.3	42.7	550.4	45.6	706.1	12.1	104.1	44.1	587.3	46.5	746.1	12.6	104.9
		70	56.5	676.9	47.85	840.2	14.1	106.8	60.4	720.1	49.1	887.5	14.7	107.7	62.4	763.3	50.3	934.8	15.2	108.7
		90	Operation not recommended.																	
	150	50	39.7	514.2	43.17	661.5	11.9	98.8	42.6	551.8	44.0	702.0	12.5	99.4	44.1	589.3	44.9	742.5	13.1	99.9
		70	56.5	675.4	45.69	831.3	14.8	101.1	60.4	718.6	46.8	878.4	15.3	101.7	62.4	761.8	48.0	925.6	15.9	102.3
		90	Operation not recommended.																	
	200	50	39.7	514.9	41.66	657.0	12.4	96.6	42.6	553.1	42.4	697.9	13.0	97.0	44.1	591.4	43.2	738.9	13.7	97.4
		70	56.5	673.8	43.54	822.4	15.5	98.2	60.4	717.1	44.6	869.4	16.1	98.7	62.4	760.4	45.7	916.4	16.6	99.2
		90	Operation not recommended.																	
110	100	50	40.8	460.0	52.18	638.0	8.8	122.8	43.5	485.1	52.9	665.7	9.2	123.3	44.9	510.2	53.7	693.5	9.5	123.9
		70	57.7	616.2	55.25	804.8	11.2	126.1	61.2	658.5	56.5	851.1	11.7	127.0	63.0	700.7	57.7	897.4	12.2	127.9
		90	Operation not recommended.																	
	150	50	40.8	461.8	50.29	633.4	9.2	118.4	43.5	489.1	50.82	662.5	9.6	118.8	44.8	516.4	51.3	691.6	10.1	119.2
		70	57.5	625.1	52.78	805.2	11.8	120.7	61.0	672.2	53.8	855.7	12.5	121.4	62.8	719.4	54.8	906.3	13.1	122.1
		90	Operation not recommended.																	
	200	50	40.7	463.7	48.39	628.8	9.6	116.3	43.4	493.1	48.7	659.2	10.1	116.6	44.8	522.6	49.0	689.7	10.7	116.9
		70	57.3	634.0	50.30	805.6	12.6	118.1	60.9	686.0	51.1	860.4	13.4	118.6	62.6	738.1	51.9	915.2	14.2	119.2
		90	Operation not recommended.																	

Note: Operation in shaded areas require special attention to ensure adequate water temperature and flow rates are maintained. Operation outside the limits could result in lockout.

Wiring Schematics

Chiller with IntelliStart

97P962-01
T114T3

Legend

CC - Compressor Controller
 CCM - Compressor Protection Module
 LST - Low Voltage Lockout
 EMT - Emergency Stop
 PGH - Phase Guard Monitor
 ES - Emergency Shutdown
 LPT - Low Pressure Trip
 HP - High Pressure
 LPS - Low Pressure Switch
 S - Safety
 TB - Terminal Block

UP - Low Pressure
 LST - Low Voltage Lockout
 EMT - Emergency Stop
 PGH - Phase Guard Monitor
 ES - Emergency Shutdown
 LPT - Low Pressure Trip
 HP - High Pressure
 LPS - Low Pressure Switch
 S - Safety
 TB - Terminal Block

Open Limper
 Closed Limper
 1/4" Quick Connector
 Ground
 Relay coil

Factory low voltage wiring
 Field low voltage wiring
 Field supplied option
 Thermostat
 Relay coil

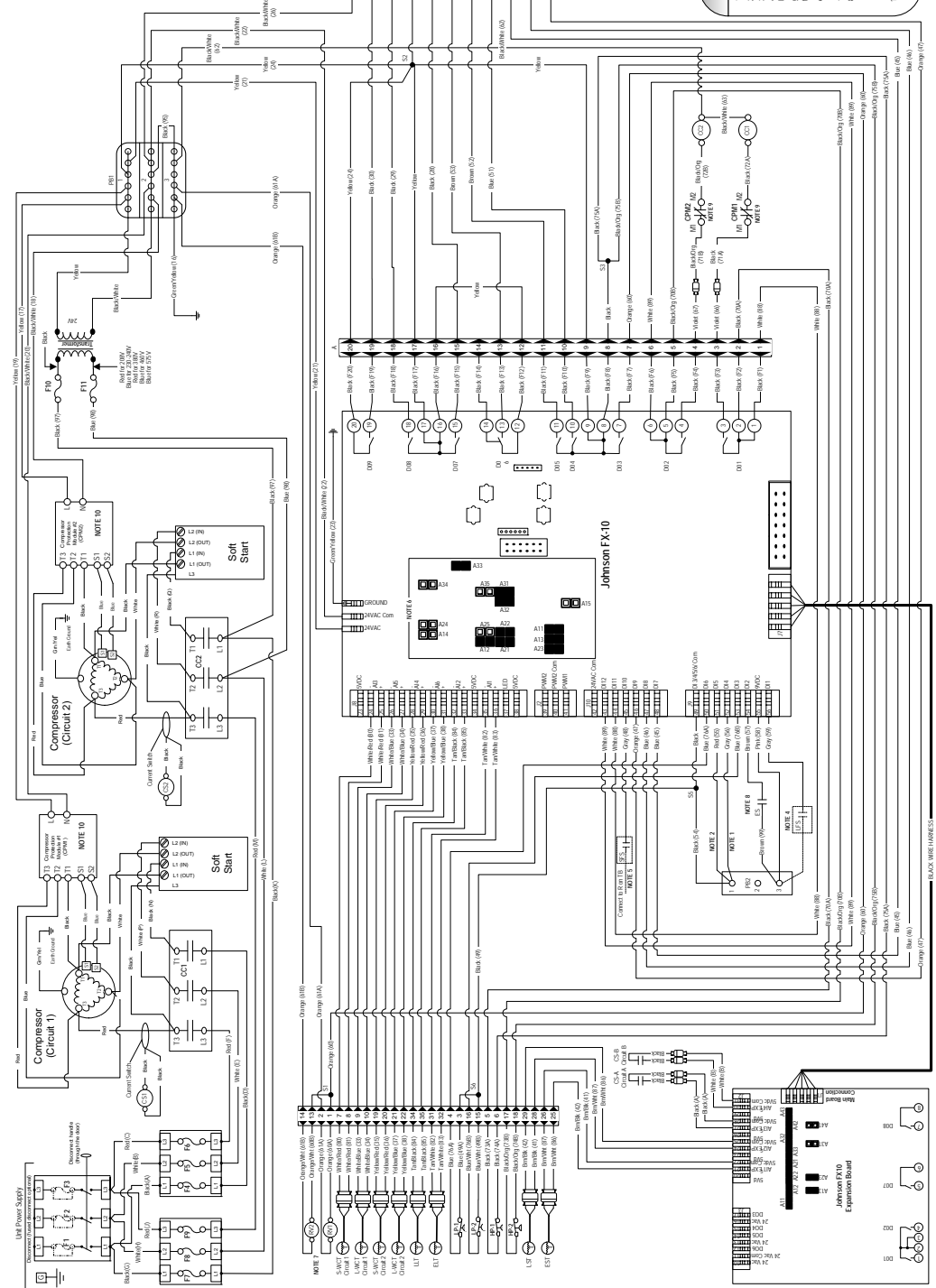

Notes

- 1 - Disconnect to 15 degree source side flow protection
- 2 - Disconnect to 15 degree source side flow protection
- 3 - Acc. CBM1 is optional with the head compressor
- 4 - All field level/low voltage is equal and/or the field side must be connected to the unit's control board.
- 5 - Jumpers must be set as shown for correct control operation. If communication card is present, it must be removed to check the jumpers.
- 6 - Jumpers must be set as shown for correct control operation. If communication card is present, it must be removed to check the jumpers.
- 7 - Reversing valve will be energized for heating mode.
- 8 - Reversing valve will be energized for heating mode.
- 9 - All field level/low voltage is equal and/or the field side must be connected to the unit's control board.
- 10 - CBM1 and CBM2 are located on the compressor protection modules (CPM1 and CPM2).

Engineering Guide Specifications

PART 1 - GENERAL

SUMMARY

The liquid source, water-to-water heat pump shall be a single packaged, reverse-cycle heating/cooling unit. Each unit shall contain microprocessor control for two hermetically sealed, scroll compressors with brazed plate heat exchangers and thermostatic expansion valves.

PERFORMANCE REQUIREMENTS

Fluid Temperature Performance:

Heat Pump shall be capable of continuous operation over the entire range of entering source-fluid temperature of 30°F – 110°F in cooling mode and 30°F – 90°F in heating mode.

Heat Pump shall be capable of continuous operation over the entire range of entering load conditions as indicated in the engineering performance tables.

SUBMITTALS

Product submittal data shall contain manufacturer's specifications for heat pumps showing dimensions, weights, capacities, performance ratings, electrical characteristics, gauges and finishes of materials and installation instructions.

Submit internal electrical wiring diagrams
Submit Control Diagrams and Specifications

QUALITY ASSURANCE

Liquid source, water-water heat pumps shall be tested, rated, and certified in accordance with the following standards.

- ASHRAE 15 for safety code for mechanical refrigeration.
- ASHRAE 147 for refrigerant leaks, recovery, and handling and storage requirements.
- ASHRAE 90.1 – minimum Energy Efficiency compliance for water-to-water heat pumps.
- Comply with NFPA 70 or National Electric Code (N.E.C)
- Comply with UL 1995 and be nationally recognized with ETL
- Tested in accordance with AHRI/ISO/ASHRAE 13256-2

Each unit shall be run tested at the factory using water. Quality control system shall automatically perform via computer: triple leak check, pressure tests, evacuate and accurately charge system, perform detailed heating and cooling mode tests, and quality cross check all operational and test conditions to pass/fail criteria. Units tested without water flow are not acceptable.

WARRANTY

Standard Warranty: The units shall be warranted by the manufacturer against defects in materials and workmanship for a period of 12 months from startup or 18 months from shipment.

Special Warranty: Manufacturer's standard form in which manufacturer agrees to repair or replace components of chillers

that fails in materials or workmanship within specified warranty period.

Extended warranties include, but are not limited to, the following:

- Complete heat pump including refrigerant and oil charge.
- Complete compressor and drive assembly.
- Parts only.

PART 2 - PRODUCTS

WATER TO WATER HEAT PUMP EQUIPMENT

Heat pump equipment shall be factory assembled with two refrigerant circuits consisting of scroll compressors, brazed-plate heat exchangers for the evaporator and condenser, microprocessor controls, and safety devices such as refrigerant pressure switches. Units must be field installed with a minimum of a differential waterside pressure switch or flow proving switch on the outlet of the load and source piping.

Frame & Enclosure

Frame shall be constructed of 10 gauge welded steel with forklift pockets in the bottom channel and threaded weld nuts for lifting points in the top of the frame.

Enclosure shall be factory installed and constructed of heavy-gauge G60 galvanized steel coated with polyester powder coat paint. Paint shall be rated for 1,000 hour of salt spray using ASTM B117. Panels, other than control service door, shall be lined with 1/2" inch thick, 1-1/2 lb/cu ft density, glass fiber glass insulation with an foil face, washable backing.

Compressor:

1. Hermetically sealed, scroll compressors with factory charged POE or PVE oil.
2. Suction gas cooled motors operate at 3500 rpm protected by internal overload device. Model sizes 600 protected by external compressor protection module.
3. Brazed connections to system piping utilizing braided stainless steel vibration absorbers on all suction and discharge piping to mitigate vibration.
4. Compressors can be operated separately to provide staged capacity for lighter load conditions.
5. Factory mounted with rubber isolation grommets.
6. Acoustically insulated sound blankets are factory installed around the compressor to reduce sound emanating from the compressor.

Engineering Guide Specifications cont.

Heat Exchangers:

1. The water to refrigerant heat exchangers shall be dual circuit, copper-brazed 316 stainless steel channel plates, capable of withstanding 650 psig working pressure on the refrigerant side and 450 psig on the water side. Refrigerant circuits are separate with a common water supply. This provides optimal part load efficiency compared to using two single circuit heat exchangers. Heat exchangers are designed to work as an evaporator and condenser.
2. Heat exchangers are covered with 3/4" closed-cell insulation on sizes 120-240 and 1" closed-cell insulation on sizes 360-600.
3. Water line connections attached to the heat exchangers are groove type are factory installed with groove coupling and steel pipe nipple. Pipe nipple is insulated and comes with 1/4" NPT pressure/temperature port.

Refrigerant Components:

1. Unit shall utilize R-410A refrigerant type. All system components shall be rated to appropriate UL standards to handle maximum system pressure.
2. Factory charged, sealed system contains optimal refrigerant quantity.
3. Each refrigerant circuit shall utilize a thermostatic expansion valve (TXV) with stainless steel sensing bulb and laser welded diaphragm. TXV will control adequate superheat over the stated operating range as indicated in submittal data.
4. Bidirectional, liquid line filter driers are to be factory installed to provide additional system cleanliness.
5. Factory installed service ports for high and low pressure readings.
6. Optional factory installed pressure gauges mounted below control panel aid in field diagnostics and reduces need for technician applied gauges.

Control Panel

1. Factory installed, wired, and functionally tested at factory before shipment.
2. Single-point power connection to non-fused, or fused rotary-type disconnect in control panel.
3. Factory installed, DIN mounted CUBEFuse with Class J rating wired for protection of each compressor.
4. Low voltage, emergency stop button factory wired and mounted to control panel service door.
5. Factory mounted class 2, control power transformer provides nominal 24 VAC low voltage power supply. Primary to transformer is protected by Class CC fuses.
6. High pressure cut out set at 600 PSIG with manual reset.
7. Low pressure cut out set at 40 PSIG with manual reset.
8. Unit shall have phase loss/reversal for compressor protection.

Controls:

1. The unit shall be controlled using a microprocessor which sequences all functions and modes of operations.
2. Units shall be capable to communicate thru standard DDC protocols such as N2, Lon, and BACnet (MS/TP @ 19,200 Baud Rate).
3. Standalone, non-communicating units are also available that will operate with thermostat, mechanical, or electronic signals. Temperature set mode is capable of controlling to leaving/entering load temperature.
4. The control system shall have the following features:
 - Anti-short cycle time delay of 5 minutes on compressor operation.
 - Random start on power up mode
 - Low voltage protection
 - High voltage protection
 - Unit shut down on high or low refrigerant pressures
 - Unit shut down for freeze detection
 - Source and Load heat exchanger freeze detection setpoint selectable for water or antifreeze
 - Automatic intelligent reset
5. A 4 x 20 digit backlit LCD to display the following:
 - Entering and leaving water temperatures
 - High pressure, low pressure, low voltage, high voltage, freeze detection setpoint, and control status
 - The low pressure shall not be monitored for the first 120 seconds after a compressor start command to prevent nuisance safety trips
 - Remote fault indication on the thermostat
 - An accessory relay output tied to each compressor selectable for normally open or normally closed
6. Control Inputs:
 - Start/Stop
 - Lead/Lag
 - Freeze detection set point for load/source
 - Water temperature set point
 Control Outputs:
 - Status: Cooling/Heating/On/Off
 - Load Side Supply and Return Temperatures
 - Source Side Supply and Return Temperatures
 - Evaporator Entering Refrigerant Temperatures
 - Condenser Leaving Refrigerant Temperatures

Accessories:

1. Additional Items Not Listed Previously:
 - Compressor sound blankets to reduce sound power level of unit.
 - Flow switch to monitor the units presence of flow.
2. Flow Proving Switch
 - A flow proving switch shall be available utilizing high reliability flow sensing technology.

Engineering Guide Specifications cont.

3. Water Connection Adaptor
 - Accessory adaptors shall be available to connect the Victaulic type fitting to a 2 in. [50.8 mm] IPT and to a 2 in. [50.8 mm] bolted flange. Accessory adaptors shall also be available to connect the Victaulic type fitting to a 2 in. MPT through a braided stainless steel flexible hose with a 400 psi burst rating and a 2 in. pipe union.
4. Differential Pressure Switch
5. Strainers
 - A strainer connection kit shall be available and includes a 2 in. [50.8 mm] Y-strainer with self-aligning screen and 1 in. [25.4 mm] blow-off port to reduce debris that will enter the heat exchanger. Strainers should be made of a brass body with a 316 stainless steel screen. Connection kit shall also include two 2 in. [50.8 mm] wrought copper tees with integral pressure/temperature port.
6. Vibration Isolators
 - Heavy duty mounting springs shall be available for corner mounting and 3 dBA noise reduction. Springs shall be field adjustable and load rated for application.

PART 3 - EXECUTION

CHILLER INSTALLATION

Install chillers on support structure indicated.

Equipment Mounting: Install chiller on concrete bases using elastomeric pads. Comply with requirements for vibration isolation devices specified in Division 23 Section "Vibration and Seismic Controls for HVAC Piping and Equipment."

- Minimum Deflection: 1/4 inch.
- Install dowel rods to connect concrete base to concrete floor. Unless otherwise indicated, install dowel rods on 18-inch centers around the full perimeter of concrete base.
- For supported equipment, install epoxy-coated anchor bolts that extend through concrete base and anchor into structural concrete floor.
- Place and secure anchorage devices. Use setting drawings, templates, diagrams, instructions, and directions furnished with items to be embedded.
- Install anchor bolts to elevations required for proper attachment to supported equipment.

Equipment Mounting: Install chiller using elastomeric pads. Comply with requirements for vibration isolation devices specified in Division 23 Section "Vibration and Seismic Controls for HVAC Piping and Equipment."

Equipment Mounting: Install chiller on concrete bases. Comply with requirements for concrete base specified by contractor.

- Install dowel rods to connect concrete base to concrete floor. Unless otherwise indicated, install dowel rods on 18-inch centers around the full perimeter of concrete base.
- For supported equipment, install epoxy-coated anchor bolts that extend through concrete base and anchor into structural concrete floor.
- Place and secure anchorage devices. Use setting drawings, templates, diagrams, instructions, and directions furnished with items to be embedded.
- Install anchor bolts to elevations required for proper attachment to supported equipment.

Maintain manufacturer's recommended clearances for service and maintenance.

Charge chiller with refrigerant and fill with oil if not factory installed.

Install separate devices furnished by manufacturer and not factory installed.

CONNECTIONS

Comply with requirements for piping specified in Division 23 Section "Hydronic Piping." Drawings indicate general arrangement of piping, fittings, and specialties.

Install piping adjacent to chiller to allow service and maintenance.

Evaporator Fluid Connections: Connect to evaporator inlet with shutoff valve, strainer, flexible connector, thermometer, and plugged tee with pressure gage. Connect to evaporator outlet with shutoff valve, balancing valve, flexible connector, flow switch, thermometer, plugged tee with shutoff valve and pressure gage, flow meter, and drain connection with valve. Make connections to chiller with a flange.

Condenser Fluid Connections: Connect to condenser inlet with shutoff valve, strainer, flexible connector, thermometer, and plugged tee with pressure gage. Connect to condenser outlet with shutoff valve, balancing valve, flexible connector, flow switch, thermometer, plugged tee with shutoff valve and pressure gage, flow meter, and drain connection with valve. Make connections to chiller with a flange.

Connect each chiller drain connection with a union and drain pipe, and extend pipe, full size of connection, to floor drain. Provide a shutoff valve at each connection.

STARTUP SERVICE

Engage a factory-authorized service representative to perform startup service.

- Complete installation and startup checks according to

Engineering Guide Specifications cont.

manufacturer's written instructions.

- Verify that refrigerant charge is sufficient and chiller has been leak tested.
- Verify that pumps are installed and functional.
- Verify that thermometers and gages are installed.
- Operate chiller for run-in period.
- Check bearing lubrication and oil levels.
- For chillers installed indoors, verify that refrigerant pressure relief device is vented outdoors.
- Verify proper motor rotation.
- Verify static deflection of vibration isolators, including deflection during chiller startup and shutdown.
- Verify and record performance of fluid flow and low-temperature interlocks for evaporator and condenser.
- Verify and record performance of chiller protection devices.
- Test and adjust controls and safeties. Replace damaged or malfunctioning controls and equipment.

Inspect field-assembled components, equipment installation, and piping and electrical connections for proper assembly, installation, and connection.

Prepare test and inspection startup reports.

Notes

Revision Guide

Pages:	Description:	Date:	By:
All	First Published	14 Aug 2014	MA

SC2502WG 08/14

Product: **GeoStar Aston GXW**
Type: Reversible Chiller - 60 Hz
Size: 10-50 Tons
Document: Specification Catalog