



SPECIFICATION CATALOG

GEO THERMAL HEAT PUMPS



AFFORDABLE RENEWABLE CLEAN



MAGNOLIA SERIES

Table of Contents

General Introduction	4
Model Nomenclature	5
AHRI Data	6-7
The Y Series	8-11
Inside the Y Series	12-14
Controls	15-16
Water Quality	17
Dimensional Data	18-20
Physical Data	21
Auxiliary Heat Ratings	22
Electrical Data	23
Blower Performance Data	24-25
Antifreeze Corrections	26
Reference Calculations	27
Legends and Notes	27
Operating Limits	28
Correction Factor Tables	28
Pressure Drop	29
Performance Data	30-43
Wiring Schematics	44-47
Engineering Guide Specifications	48-50

Y Series



The Y Series benefits from the technology we have refined through four generations of products. The Y Series is an exceptional value offering high unit efficiencies, years of reliable energy savings, and superb comfort.

All Y Series units utilize ozone-safe R-410A refrigerant to meet the most stringent EPA requirements. Coated air coils add durability and longer life. X13 ECM blowers are used to increase comfort and efficiency. A simplified microprocessor control sequences components during operation for optimum performance, and provides easy-to-use troubleshooting features with fault lights and on-board diagnostics. Unit configurations include vertical top discharge (left or right return) and horizontal units with left or right return, side or end discharge. Heavy-gauge metal cabinets are fully insulated and coated with an attractive and durable paint for long lasting protection.

Y Series products are: performance-certified to AHRI/ISO 13256-1 standards, ETL listed, and all model sizes are available as ENERGYSTAR® qualified.

As a leader in the industry, we are dedicated to innovation, quality and customer satisfaction. In fact, every unit built is exposed to a wide range of quality control procedures throughout the assembly process and is then subjected to a rigorous battery of computerized run tests to certify that it meets or exceeds performance standards for efficiency and safety, and will perform flawlessly at startup. As further affirmation of our quality standards, each unit carries our exclusive Quality Assurance emblem, signed by the final test technician.



All Y Series product is safety listed under UL1995 thru ETL and performance listed with AHRI in accordance with standard 13256-1. The Y Series is also Energy Star rated.

Model Nomenclature

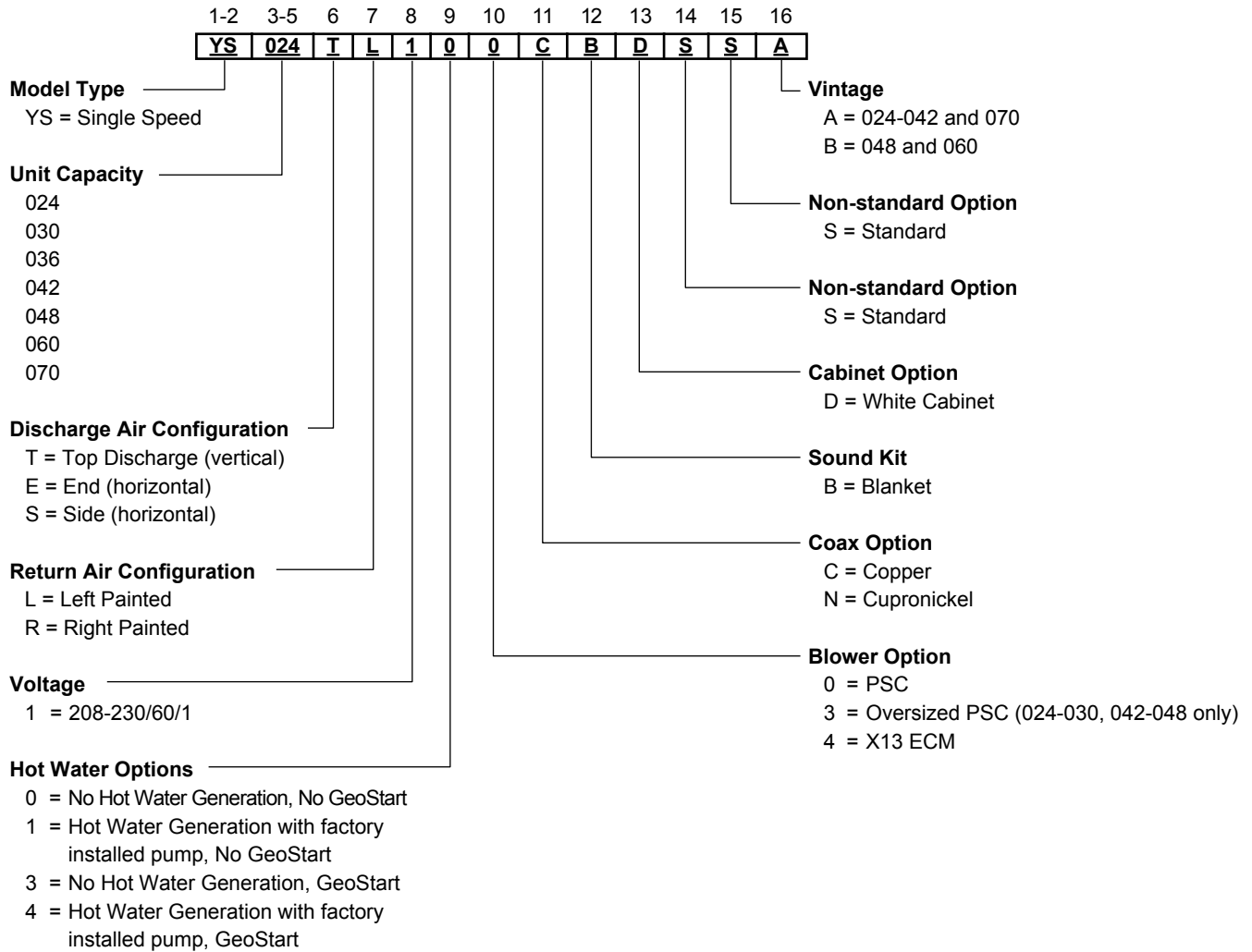

AHRI Data

PSC Motor

AHRI/ASHRAE/ISO 13256-1

English (IP) Units

Model	Capacity Modulation	Flow Rate		Water Loop Heat Pump				Ground Water Heat Pump				Ground Loop Heat Pump			
				Cooling EWT 86°F		Heating EWT 68°F		Cooling EWT 59°F		Heating EWT 50°F		Cooling EWT 77°F		Heating EWT 32°F	
		gpm	cfm	Capacity Btuh	EER Btuh/W	Capacity Btuh	COP	Capacity Btuh	EER Btuh/W	Capacity Btuh	COP	Capacity Btuh	EER Btuh/W	Capacity Btuh	COP
024	Single	6.0	800	23,900	14.6	27,000	4.7	26,400	22.8	22,300	4.0	24,400	17.0	17,500	3.5
030	Single	8.0	1000	29,500	14.9	34,600	4.8	32,900	23.0	28,300	4.0	29,000	17.0	22,800	3.5
036	Single	9.0	1150	33,300	14.4	40,600	4.5	37,700	21.2	33,000	3.9	34,500	16.6	26,000	3.3
042	Single	11.0	1400	40,800	14.5	45,400	4.5	45,800	22.0	37,000	3.8	42,300	16.8	29,900	3.3
048	Single	12.0	1600	47,700	14.7	56,000	4.4	52,000	21.0	45,900	3.8	49,500	16.8	36,900	3.3
060	Single	15.0	1900	58,400	14.7	72,500	4.4	65,500	20.8	58,400	3.8	60,900	16.6	47,100	3.3
070	Single	18.0	2100	63,000	14.2	79,000	4.4	70,000	20.3	64,100	3.8	68,500	15.2	51,600	3.3

Cooling capacities based upon 80.6°F DB, 66.2°F WB entering air temperature

Heating capacities based upon 68°F DB, 59°F WB entering air temperature

All ratings based upon 208V operation

11/12/10

X13 ECM Motor

AHRI/ASHRAE/ISO 13256-1

English (IP) Units

Model	Capacity Modulation	Flow Rate		Water Loop Heat Pump				Ground Water Heat Pump				Ground Loop Heat Pump			
				Cooling EWT 86°F		Heating EWT 68°F		Cooling EWT 59°F		Heating EWT 50°F		Cooling EWT 77°F		Heating EWT 32°F	
		gpm	cfm	Capacity Btuh	EER Btuh/W	Capacity Btuh	COP	Capacity Btuh	EER Btuh/W	Capacity Btuh	COP	Capacity Btuh	EER Btuh/W	Capacity Btuh	COP
024	Single	6.0	800	23,000	15.1	27,000	5.0	26,400	23.4	22,300	4.5	24,400	17.5	17,500	3.8
030	Single	8.0	1000	29,500	15.7	34,600	5.1	32,900	23.9	28,300	4.4	29,000	18.3	22,800	3.8
036	Single	9.0	1150	33,300	15.0	40,600	4.8	37,700	23.0	33,000	4.3	34,500	17.3	26,000	3.5
042	Single	11.0	1400	40,800	15.6	45,400	5.0	45,800	23.5	37,000	4.3	42,300	18.5	29,900	3.7
048	Single	12.0	1600	47,700	15.5	56,000	4.8	52,000	23.4	45,900	4.2	49,500	18.1	36,900	3.6
060	Single	15.0	1900	58,400	15.3	72,500	4.7	65,500	23.0	58,400	4.0	60,900	17.9	47,100	3.6
070	Single	18.0	2100	63,000	14.3	79,000	4.7	70,000	21.0	64,100	4.0	68,500	16.1	51,600	3.5

Cooling capacities based upon 80.6°F DB, 66.2°F WB entering air temperature

Heating capacities based upon 68°F DB, 59°F WB entering air temperature

All ratings based upon 208V operation

11/12/10

Energy Star Compliance Table

Model	Tier 1		Tier 2		Tier 3	
	Ground Water	Ground Loop	Ground Water	Ground Loop	Ground Water	Ground Loop
024	X, P	X, P	X, P	X, P	X	X
030	X, P	X, P	X, P	X, P	X	X
036	X, P	X, P	X, P	X	X	-
042	X, P	X, P	X, P	X	X	X
048	X, P	X, P	X, P	X	X	X
060	X, P	X, P	X, P	X	-	X
070	X, P	X, P	X, P	X	-	-

X - Unit with X13 Blower

P - Unit with PSC Blower

3/18/11

Energy Star Rating Criteria

In order for water-source heat pumps to be Energy Star rated they must meet or exceed the minimum efficiency requirements listed below. Please note there are 3 Tier levels that dictate minimum efficiency for water source heat pumps. Only one tier level is active at a given moment.

Tier 1: 12/1/2009 – 12/31/2010

Water-to-Air	EER	COP
Ground Loop	14.1	3.3
Ground Water	16.2	3.6
Water-to-Water		
Ground Loop	15.1	3.0
Ground Water	19.1	3.4

Tier 2: 1/1/2011 – 12/31/2011

Water-to-Air	EER	COP
Ground Loop	16.1	3.5
Ground Water	18.2	3.8
Water-to-Water		
Ground Loop	15.1	3.0
Ground Water	19.1	3.4

Tier 3: 1/1/2012 – No Effective End Date Published

Water-to-Air	EER	COP
Ground Loop	17.1	3.6
Ground Water	21.1	4.1
Water-to-Water		
Ground Loop	16.1	3.1
Ground Water	20.1	3.5

AHRI Data cont.

The performance standard AHRI/ASHRAE/ISO 13256-1 became effective January 1, 2000 and replaces AHRI Standards 320, 325, and 330. This new standard has three major categories: Water Loop (comparable to ARI 320), Ground Water (ARI 325), and Ground Loop (ARI 330). Although these standards are similar there are some differences:

Unit of Measure: The Cooling COP

The cooling efficiency is measured in EER (US version measured in Btuh per Watt. The Metric version is measured in a cooling COP (Watt per Watt) similar to the traditional COP measurement.

Water Conditions Differences

Entering water temperatures have changed to reflect the centigrade temperature scale. For instance the water loop heating test is performed with 68°F (20°C) water rounded down from the old 70°F (21.1°C).

Air Conditions Differences

Entering air temperatures have also changed (rounded down) to reflect the centigrade temperature scale. For instance the cooling tests are performed with 80.6°F (27°C) dry bulb and 66.2°F (19°C) wet bulb entering air instead of the traditional 80°F (26.7°C) DB and 67°F (19.4°C) WB entering air temperatures. 80.6/66.2 data may be converted to 80/67 using the entering air correction table. This represents a significantly lower relative humidity than the old 80/67 of 50% and will result in lower latent capacities.

Pump Power Correction Calculation

Within each model, only one water flow rate is specified for all three groups and pumping Watts are calculated using the following formula. This additional power is added onto the existing power consumption.

- Pump power correction = (gpm x 0.0631) x (Press Drop x 2990) / 300

Where 'gpm' is waterflow in gpm and 'Press Drop' is the pressure drop through the unit heat exchanger at rated water flow in feet of head.

Blower Power Correction Calculation

Blower power is corrected to zero external static pressure using the following equation. The nominal airflow is rated at a specific external static pressure. This effectively reduces the power consumption of the unit and increases cooling capacity but decreases heating capacity. These Watts are significant enough in most cases to increase EER and COPs fairly dramatically over ARI 320, 325, and 330 ratings.

- Blower Power Correction = (cfm x 0.472) x (esp x 249) / 300

Where 'cfm' is airflow in cfm and 'esp' is the external static pressure at rated airflow in inches of water gauge.

ISO Capacity and Efficiency Calculations

The following equations illustrate cooling calculations:

- ISO Cooling Capacity = Cooling Capacity (Btuh) + (Blower Power Correction (Watts) x 3.412)
- ISO EER Efficiency (W/W) = ISO Cooling Capacity (Btuh) x 3.412 / [Power Input (Watts) - Blower Power Correction (Watts) + Pump Power Correction (Watt)]

The following equations illustrate heating calculations:

- ISO Heating Capacity = Heating Capacity (Btuh) - (Blower Power Correction (Watts) x 3.412)
- ISO COP Efficiency (W/W) = ISO Heating Capacity (Btuh) x 3.412 / [Power Input (Watts) - Blower Power Correction (Watts) + Pump Power Correction (Watt)]

Comparison of Test Conditions

	ARI 320	ISO/AHRI 13256-1 WLHP	ARI 325	ISO/AHRI 13256-1 GWHP	ARI 330	ISO/AHRI 13256-1 GLHP
Cooling						
Entering Air - DB/WB °F	80/67	80.6/66.2	80/67	80.6/66.2	80/67	80.6/66.2
Entering Water - °F	85	86	50/70	59	77	77
Fluid Flow Rate	*	**	**	**	**	**
Heating						
Entering Air - DB/WB °F	70	68	70	68	70	68
Entering Water - °F	70	68	50/70	50	32	32
Fluid Flow Rate	*	**	**	**	**	**

Note *: Flow rate is set by 10°F rise in standard cooling test Part load entering water conditions not shown.

Note **: Flow rate is specified by the manufacturer

WLHP = Water Loop Heat Pump; GWHP = Ground Water Heat Pump; GLHP = Ground Loop Heat Pump

Conversions:

Airflow (lps) = CFM x 0.472;

ESP (Pascals) = ESP (in wg) x 249;

Water Flow (lps) = GPM x 0.0631;

Press Drop (Pascals) = Press Drop (ft hd) x 2990

The Y Series

The Y Series benefits from the technology we've refined through four generations of products, and offers years of reliable energy savings and comfort. The product features high efficiency and great value in a cabinet designed for both retrofit and new construction. The Y Series contains the following standard features:

- Capacity selections available from 024-070 kBtuh output
- Available in 208-230 V/60 Hz/1ph
- Industry leading quality through engineering and manufacturing using quality components
 - High Efficiency and reliable scroll compressors
 - High Efficiency X13 ECM blower motor or optional 3 speed PSC
- High efficiency performance for maximizing LEED points
 - EnergyStar Rating on all models with the X13 ECM and on selected PSC models
 - With X13 ECM Blower Motor Up to 18.5 EER and 3.8 COP (ISO/AHRI 13256-1 GLHP)
 - With PSC Blower Motor Up to 17.0 EER and 3.5 COP (ISO/AHRI 13256-1 GLHP)
- Residential features such as:
 - Brass swivel union water connections
 - Field installed internal electric heat
 - Internally trapped condensate (vertical only)
 - Designed for front access in tight applications
 - Five (5) access panels for easy servicing (four (4) on horizontal)
 - Built-in hot water generator and pump
 - Flow center control
- Foil lined cleanable insulation
- Electro-coated air coils for extended life
- Coaxial heat exchangers foam insulated to prevent condensation in low temperature loop applications
- LED fault and status lights for easy diagnostics
- Double isolation mounted compressors with compressor sound blanket
- Standard 1 in. MERV8 filter with deluxe filter rack field switchable between 1 in. and 2 in.
- Wide array of standard factory options including:
 - Configurations – vertical and horizontal left and right return
 - X13 ECM or 3 speed PSC blower motor – high static options available on some PSC
 - Copper or cupronickel coaxial heat exchanger
 - Internal hot water generator with factory installed pump
 - Corrosion-proof composite drain pan
 - GeoStart™ compressor soft starter to reduce compressor starting current



Vertical Y Series

Models YS 024-070 (2-6 tons) Single Speed

Horizontal Y Series

Models YS 024-070 (2-6 tons) Single Speed

The Y Series cont.

Product Features: Vertical Cabinet

Y Series vertical units are designed for high efficiency, maximum flexibility, and easy service access.

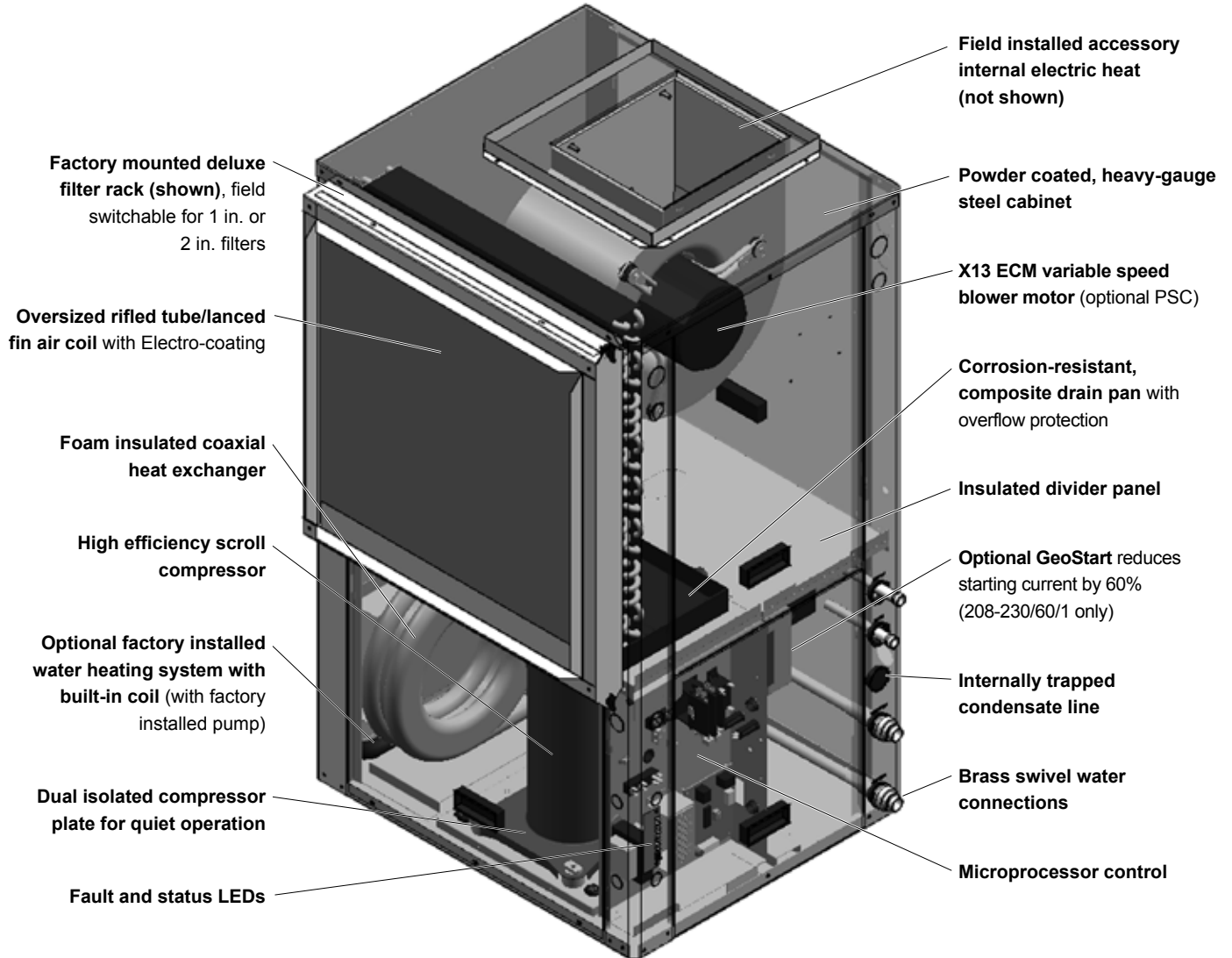

The Y Series cont.

Product Features: Horizontal Cabinet

Y Series horizontal units are available in four cabinet sizes. The cabinets are designed for high efficiency, maximum flexibility, and easy service access.

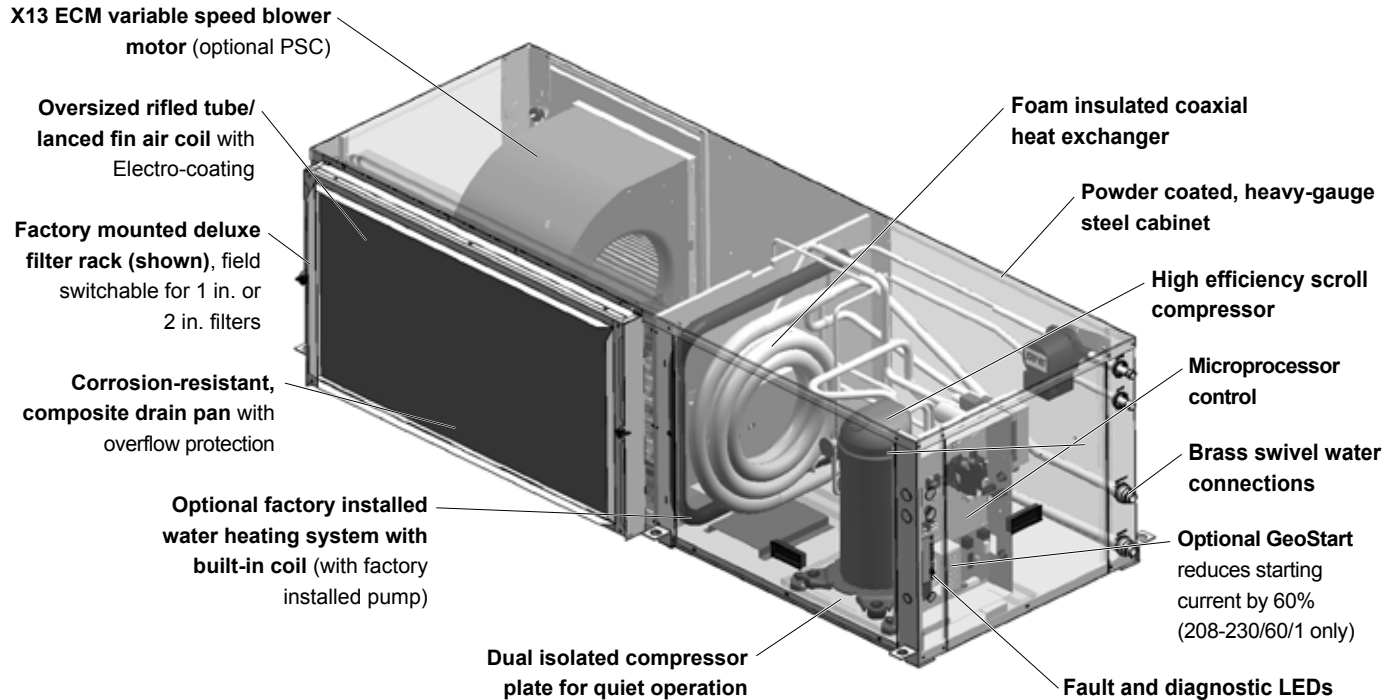

Flexible Product with Several Standard Options

- Cabinet designed for new construction application and retrofit of over 100,000 Premier™ units.
- Horizontal units with end and side discharge and vertical units with top discharge air configurations
- Capacities of 24,000 through 70,000 Btuh
- Hot water generation
- GeoStart soft starter (208-230/60/1 only)
- X13 ECM or 3 speed PSC blower motor - high static options available on some PSC
- Electro-coated air coils
- Copper or cupronickel heat exchangers with foam insulation
- Super Quiet Sound Package, including multi-density compressor blanket
- Quiet scroll compressors in all models
- 2-dimension refrigerant piping vibration loops to isolate the compressor
- Double isolated compressor mounting utilizing 8 durometer selected rubber grommets and high density steel
- Heavy gauge cabinet and brackets (4 on 024-036 horizontal models or 6 on 042-070 horizontal models)
- Standard microprocessor controls
- Durable powder coat paint for long lasting protection
- Polymer composite drain pan
- 1 in. MERV 8 filter

High Efficiency

The Y Series is a high efficiency watersource heat pump. The product features highly efficient and reliable single capacity scroll compressors mated with a large blower driven by efficient X13 ECM motors or optional 3-speed PSC motors.

Indoor Air Quality (IAQ)

All Y Series features several IAQ benefits:

- Corrosion-free composite double-sloped drain pan to eliminate standing water and prevent bacterial growth
- Foil-faced fibre insulation in all air handler compartments to allow cleanability and inhibit bacteria growth.
- Factory mounted, four sided, deluxe filter rack that is field switchable from 1 in. to 2 in. [2.54 to 5.1 cm] is available for ducted return applications.
- Standard supplied filter is a pleated MERV 8, 1 in. [2.54 cm].



The Y Series cont.

Application Flexibility

- Safe, efficient operation in a wide range of liquid temperatures (20°F to 120°F) and flow rates (as low as 1.5 GPM/ton in open loop applications when EWT >50°F).
- Top air discharge for upflow installations in vertical units, side or end discharge for horizontal units.
- True left or right return air locations—all units include filter rack/duct collar.
- Five-speed X13 ECM blowers permit various duct applications. Optional PSC motors also available.
- Narrow cabinet for easy movement through doorways.
- Internally trapped condensate piping for neat, compact installation (vertical units only).
- Optional field-installed auxiliary electric heater.
- Corner-located electrical box for field wiring from two sides.
- Circuit breaker-protected loop pump power block for easy wiring.
- Field-selectable freeze detection setting for well or closed loop systems.

Operating Efficiencies

- AHRI/ISO 13256-1 rating for heating COPs, cooling EERs and low water flow requirements.
- Optional hot water generator with internal pump generates hot water at considerable savings while improving overall system efficiency.
- High-stability expansion valve delivers optimum refrigerant flow over a wide range of conditions and provides bidirectional operation without troublesome check valves.
- Efficient scroll compressors operate quietly.
- Oversized coaxial tube water-to-refrigerant heat exchanger operates at low liquid pressure drops.
- Convoluted copper water tube functions efficiently at low flow rates.
- Oversized rifled copper tube/lanced aluminum fin air-to-refrigerant heat exchanger provides high efficiencies at low-face velocity.
- Large, low-RPM blowers with multi-speed X13 ECM motors provide quiet and efficient air movement with high static capability. Optional 3-speed PSC motors also available.
- Utilizes the ozone-friendly R-410A refrigerant which produces higher efficiencies and warmer discharge air temperatures.

Easy Maintenance and Service Advantages

- Removable panels: three for the compressor compartment and two (on verticals) or one (on horizontals) for the air handling compartment to provide quick access to all internal components with ductwork in place.
- Easily accessible thermal expansion valve.
- Brass, swivel-type water connections for quick connection union, and elimination of wrenches and sealants during installation.
- Insulated divider and separate air handling/compressor access panels permit service testing without air bypass.
- Designed for front access in tight applications.
- LED fault and status lights with memory for easy diagnostics.
- Internal drop-out blower with permanently-lubricated ball bearing motor.
- High- and low-pressure service ports in refrigerant circuit.
- Blower and transformer powered from auxiliary heat supply (when installed) to provide emergency heat with open compressor circuit breaker.

Factory Quality

- All refrigerant brazing is performed in a nitrogen environment.
- Computer controlled deep vacuum and refrigerant charging system.
- All joints are leak detected for maximum leak rate of less than 1/4 oz. per year.
- Computer bar code equipped assembly line insures all components are correct.
- All units are computer run-tested with water to verify both function and performance.

Inside the Y Series

Refrigerant

Y Series products all feature zero ozone depletion and low global warming potential refrigerant R410A.

Cabinet

All units are constructed of corrosion resistant galvanized sheet metal with powder coat paint rated for more than 1,000 hours of salt spray. Refrigerant circuit is designed to allow primary serviceability from the front. Four (4) horizontal and five (5) vertical cabinets are provided for application flexibility. The blower motor and blower can be completely serviced or replaced without removal of the unit.

Filter Rack

All units come standard with a deluxe filter rack/duct collar for use with ducted returns. The filter rack is field switchable between 1 in. [2.54 cm] and 2 in. [5.1 cm] thick filters for filter flexibility. A MERV 8, 1 in. [2.54 cm] is standard.



Electrical Box

Unit controls feature quick connect wiring harnesses for easy servicing. Separate knockouts for LV, and two for power on two sides allow easy access to the control box. Large 75VA transformer assures adequate controls power for accessories.



Internal Electric Heat (Accessory)

The EA series electric auxiliary heater mounts internally in vertical units to provide supplemental and/or emergency heating capability. On horizontal units, the EA series electric auxiliary heater control box mounts internally while the electric resistance coil assembly mounts externally. The auxiliary heater uses a control board which contains the line voltage element control relays.

The auxiliary heat element rack and control box are separate assemblies which are connected with modular "quick-connect" plugs. The auxiliary heater feeds line voltage power to the blower

and unit transformer to provide emergency heat capability in the event of an open compressor circuit breaker (caused by a malfunctioning compressor).

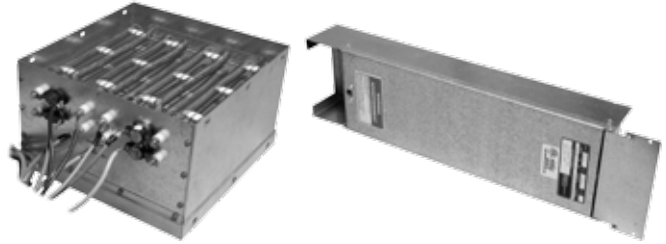

Water Connections

Supply and return water connections are 1 in. [2.54 cm] FPT brass swivel fittings, which eliminate the need for pipe wrenches and sealants when making field connections.



Horizontal Hanger Kits

Each horizontal unit includes a hanger kit to meet seismic specification requirements while still allowing filter access.



Inside the Y Series cont.

Drain Pan

All condensate connections are PVC glue for economical corrosion free connections. Bacteria resistant composite drain pan is sloped to promote complete drainage and will never rust or corrode. Complete drainage helps to inhibit bacterial or microbial growth. Vertical units feature an internally trapped condensate line using clear PVC hose for easy inspection and reduced installation cost.



Compressors

High efficiency R-410A scroll compressors are used on every model. Scrolls provide both the highest efficiency available and great reliability.



Compressor Dual Isolation Mounting

Double isolated compressor mounting utilizing eight durometer selected rubber grommets and high density steel. This isolation greatly reduces the primary noise frequency range of 100-300 Hz.



Air Handler Insulation

Foil Faced air handler insulation provides cleanability to further enhance IAQ.



Thermostatic Expansion Valve

All Y Series models utilize a balanced port bidirectional thermostatic expansion valve (TXV) for refrigerant metering. This allows precise refrigerant flow in a wide range of entering water variation (20 to 120°F [-7 to 49 °C]) found in geothermal systems. The TXV is located in the compressor compartment for easy access.



Inside the Y Series cont.

Water-to-Refrigerant Coaxial Heat Exchanger Coil

Large oversized coaxial refrigerant to water heat exchangers provide unparalleled efficiency. The coaxes are designed for low pressure drop and low flow rates. All coaxes are pressure rated to 450 psi water side and 600 psi on the refrigerant side. Each water-to-refrigerant heat exchanger is foam insulated to prevent condensation in low temperature loop operation.



Blower Motor and Housing

High efficiency low rpm galvanized direct drive blower featuring 5 speed X13 ECM motor and optional 3 speed permanently split capacitor (PSC) blower motor. The lower rpm blower also reduces the air noise. All X13 ECM and PSC motors have speed selection terminal strip on the motor for easy speed change. All motors are vibration isolated to reduce noise. High static options are available in some models for PSC motor versions.



Service Connections and Serviceability

Two Schrader service ports are provided in every unit. The suction side and discharge side ports are for field charging and servicing access. All valves are 7/16" SAE connections. All water and electrical connections are made from the front of the unit. Unit is designed for front access serviceability.



X13 ECM Constant Torque Motors

The X13 is a 'Constant Torque' ECM motor and delivers air flow similar to a PSC but operates as efficiently as an ECM Variable Speed Motor. Because it's an ECM Motor, the X13 can ramp slowly up or down like the ECM Variable Speed Motor. There are 5 possible speed taps available on the X13 motor with #1 being the lowest airflow and #5 being the highest airflow. These speed selections are preset at the time of manufacture and are easily changed in the field if necessary. The G, Y1 and W signals are wired to the motor at the factory. A gray wire is tied to the motor wire bundle for the Y2 signal and can be field connected to the motor if desired.

4-Way Reversing Valve

Y Series units feature a reliable all-brass pilot operated refrigerant reversing valve. The reversing valve operation is limited to change of mode by the control to enhance reliability.



X13 Benefits:

- High efficiency
- Soft start
- 5 speeds with up to 4 speeds on-line
- Built in logic allows air flow to change with G, Y1, Y2 and W signals
- Super efficient low airflow continuous blower setting (G)

Air Coil

Large low velocity air coils are constructed of lanced fin and rifled tube. Each model features 3 rows for added moisture removal. The coils are electro-coated for maximum protection against formicary corrosion.



GeoStart™

The optional GeoStart single phase soft starter will reduce the normal start current (LRA) by 60-70%. This reduces the start current requirements of emergency generating equipment.

Using GeoStart also provides a substantial reduction in light flicker, reduces start-up noise, and improves the compressor's start behavior. GeoStart is available in a field retrofit kit or as a factory installed option for all Y Series units.



Controls

Standard Microprocessor



Flexible Control Options

The standard control system is a microprocessor-based printed circuit board, (PCB), conveniently located in the unit control box for accessibility. The microprocessor control is specifically designed for geothermal water source heat pumps to integrate compressors and advanced features needed in geothermal water source heat pump applications. The microprocessor provides control of the entire unit as well as outputs for status modes, faults, and diagnostics. Low voltage thermostat terminal strips provide convenient field connections. LEDs are located in the corner post to assist the technician when servicing the unit.

Startup

The unit will not operate until all the inputs and safety controls are checked for normal conditions. At first powerup, a five minute delay is employed before the compressor is energized.

Component Sequencing Delays

Components are sequenced and delayed for optimum space conditioning performance.

Short Cycle Protection

The control allows a minimum on time of 2 minutes and a minimum off time of 4 minutes for short cycle protection.

Condensate Overflow Protection

The control board incorporates an impedance sensing liquid sensor at the top of the drain pan. Upon a continuous 30-second sensing of the condensate, compressor operation is suspended (see Fault Retry), and the condensate overflow lockout LED begins flashing.

Safety Controls

The control receives separate signals for a high pressure switch for safety, a low pressure switch to prevent loss of charge damage, and a low suction temperature thermistor for freeze sensing. Upon a continuous 30-second measurement of the fault (immediate for high pressure), compressor operation is suspended, the appropriate lockout LED begins flashing. (Refer to the "Fault Retry" section below).

Testing

The control allows service personnel to shorten most timing delays for faster diagnostics.

Fault Retry

All faults are retried twice before finally locking the unit out. An output signal is made available for a fault LED at the thermostat. The "Fault Retry" feature is designed to prevent nuisance service calls.

Diagnostics

The control board allows all inputs and outputs to be displayed on the LEDs for fast and simple control board diagnosis.

Emergency Shutdown

A grounded signal to common or connecting 24 VAC to the ES terminal places the controller into the emergency shutdown mode. The compressor and blower operation are suspended while in the emergency shutdown mode.

Heating Operation

Heating (Y1)

The blower motor is started immediately after the "Y1" input is received, and the compressor is energized 10 seconds after the "Y1" input.

Heat, 2nd Stage (Y1, Y2) X13 ECM

When the gray wire is connected to the motor (Y2 is field connected) the blower speed will increase.

Heat, 3rd Stage (Y1, Y2, W) X13 ECM

When a "W" input is received the blower speed will increase and all stages of resistance heat will be energized along with the compressor operation.

Emergency Heat (W only)

The blower is started on high speed and all stages of resistance heat are energized.

Cooling Operation

In all cooling operations, the reversing valve directly tracks the "O" input. Thus, anytime the "O" input is present, the reversing valve will be energized.

Cooling (Y1,O)

The blower motor is started immediately after the "Y1" input is received, and the compressor is energized 10 seconds after the "Y1" input.

Controls cont.

Cool, 2nd Stage (Y1, Y2, 0)

When the gray wire is connected to the motor (Y2 is field connected) the blower speed will increase.

Blower (G only)

The blower motor is started immediately after the "G" input is received; and it will remain on for 30 seconds at the end of each heating or cooling cycle.

Lockout Conditions

During lockout mode, the appropriate unit and thermostat lockout LEDs will illuminate. The compressor, loop pump(s), and hot water generator pump outputs are de-energized. If the thermostat calls for heating, emergency heat operation will occur. All lockout modes can be reset at the thermostat after turning the unit off, and then on, which restores normal operation but keeps the unit lockout LED illuminated. Interruption of power to the unit will reset lockout without a waiting period and clear all lockout LEDs.

High Pressure

This lockout mode occurs when the normally closed safety switch is opened momentarily (set at 600 PSI).

Low Pressure

This lockout mode occurs when the normally closed low pressure switch is opened for 30 continuous seconds (set at 40 PSI).

Freeze Detection (Water Flow)

This lockout mode occurs when the freeze thermistor temperature is at or below the selected freeze detection point (well 30°F or loop 15°F) for 30 continuous seconds.

Condensate Overflow

This lockout mode occurs when the condensate overflow level has been reached for 30 continuous seconds.

DIP Switch Settings

Prior to powering unit, ensure that all DIP switches on SW1 are set properly according to the table below.

FACTORY SETUP DIP SWITCHES (SW1)				
Dip Switch Number		Description	"OFF" Position	"ON" Position
SW1-	1	Service Test Mode On the control, allows field selection of "NORMAL" or "TEST" operational modes, Test mode accelerates most timing functions 16 times to allow faster troubleshooting. Test mode also allows viewing the "CURRENT" status of the fault inputs on the LED display.	Test Mode	Normal Speed Operation
SW1-	2	Freeze Detection Setting This DIP switch allows field selection of low source water thermistor fault sensing for "WELL" water (30°F) or "LOOP" (15°F) for antifreeze protected earth loops.	"LOOP" (15°F)	"WELL" (30°F)
SW1-	3	Not Available	N/A	Normal Operation
SW1-	4	I/O Display Mode This DIP switch enables Input/Output Display or Status/Current Fault on LED Board. Refer to SW2 for operation and positioning.	Input/Output Display Mode	Status/Current Fault Display Mode
SW1-	5	Not Available	N/A	Normal Operation
SW2-		LED Display (On LED Board) This DIP switch enables Normal Status or Input display mode in the "OFF" position and Current Fault or Output display mode in the "ON" position.	Status or Inputs Display Mode	Current Fault or Output Display Mode

11/13/09

Operation Logic Data Table

Mode	Inputs	Blower	Comp	RV
Htg	Y	Auto	ON	OFF
Clg	Y, O	Auto	ON	ON
Blower Only	G/Y2	ON	OFF	OFF

11/13/09

Water Quality

In ground water situations where scaling could be heavy or where biological growth such as iron bacteria will be present, a closed loop system is recommended. The heat exchanger coils in ground water systems may, over a period of time, lose heat exchange capabilities due to a buildup of mineral deposits inside. These can be cleaned, but only by a qualified service mechanic, as special solutions and pumping equipment are required. Hot water generator coils can likewise become scaled and possibly plugged.

In areas with extremely hard water, the owner should be informed that the heat exchanger may require occasional flushing.

Units with cupronickel heat exchangers are recommended for open loop applications due to the increased resistance to build-up and corrosion, along with reduced wear caused by acid cleaning. Failure to adhere to the guidelines in the water quality table could result in loss of warranty.

Material		Copper	90/10 Cupro-Nickel	316 Stainless Steel
pH	Acidity/Alkalinity	7 - 9	7 - 9	7 - 9
Scaling	Calcium and Magnesium Carbonate	(Total Hardness) less than 350 ppm	(Total Hardness) less than 350 ppm	(Total Hardness) less than 350 ppm
Corrosion	Hydrogen Sulfide	Less than .5 ppm (rotten egg smell appears at 0.5 PPM)	10 - 50 ppm	Less than 1 ppm
	Sulfates	Less than 125 ppm	Less than 125 ppm	Less than 200 ppm
	Chlorine	Less than .5 ppm	Less than .5 ppm	Less than .5 ppm
	Chlorides	Less than 20 ppm	Less than 125 ppm	Less than 300 ppm
	Carbon Dioxide	Less than 50 ppm	10 - 50 ppm	10 - 50 ppm
	Ammonia	Less than 2 ppm	Less than 2 ppm	Less than 20 ppm
	Ammonia Chloride	Less than .5 ppm	Less than .5 ppm	Less than .5 ppm
	Ammonia Nitrate	Less than .5 ppm	Less than .5 ppm	Less than .5 ppm
	Ammonia Hydroxide	Less than .5 ppm	Less than .5 ppm	Less than .5 ppm
	Ammonia Sulfate	Less than .5 ppm	Less than .5 ppm	Less than .5 ppm
	Total Dissolved Solids (TDS)	Less than 1000 ppm	1000-1500 ppm	1000-1500 ppm
	LSI Index	*0.5 to .05	*0.5 to .05	*0.5 to .05
Iron Fouling	Iron, Fe ²⁺ (Ferrous) Bacterial Iron Potential	< .2ppm	< .2 ppm	< .2 ppm
(Biological Growth)	Iron Oxide	Less than 1 ppm. Above this level deposition will occur.	Less than 1 ppm. Above this level deposition will occur.	Less than 1 ppm. Above this level deposition will occur.
Erosion	Suspended Solids	Less than 10 ppm and filtered for max of 600 micron size	Less than 10 ppm and filtered for max of 600 micron size	Less than 10 ppm and filtered for max of 600 micron size
	Threshold Velocity (Fresh Water)	< 6 ft/sec	< 6 ft/sec	< 6 ft/sec

Note:
Grains = PPM divided by 17
mg/l is equivalent to PPM

Horizontal Dimensional Data

Legend
 AP = Alternate Service Panel
 BP = Blower Service Panel
 CP = Control Access Panel
 CMP = Compressor Service Panel

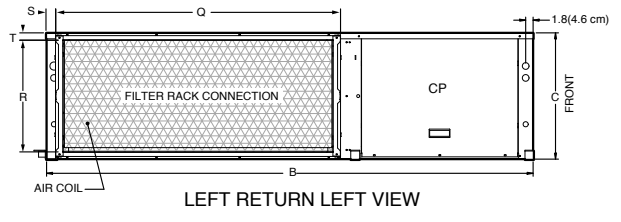
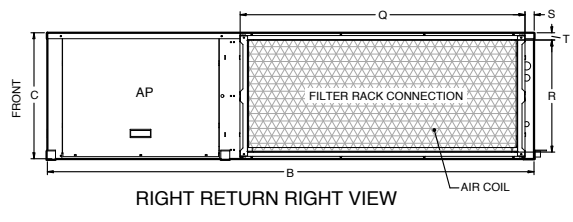
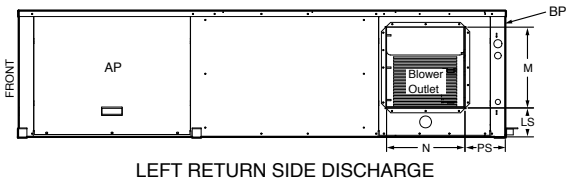
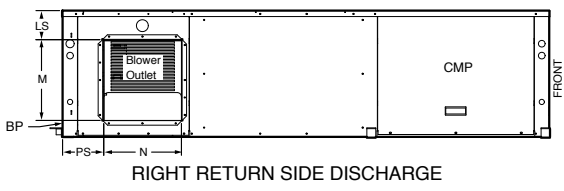
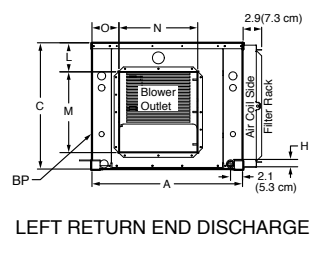
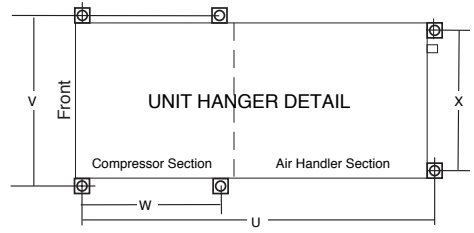
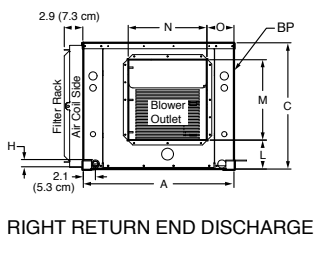
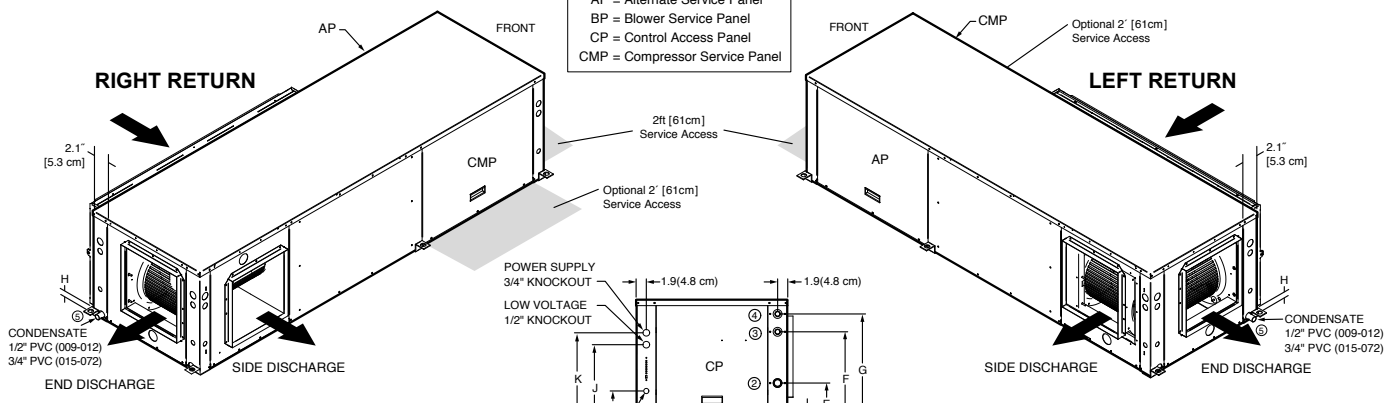

Horizontal Dimensional Data cont.

Horizontal Models	Overall Cabinet			Water Connections							Electrical Knockouts							
	A Width	B Depth	C Height*	D Loop In	E Loop Out	F HWG In	G HWG Out	H Condensate	Loop Water FPT	HWG Sweat I.D.	J 1/2" cond. Low Voltage	K 1/2" cond. Ext Pump	L 3/4" cond. Power Supply	M Low Voltage	N Ext Pump	P Power Supply	Q Elec. Heat	
024-036	in.	22.5	63.0	19.2	2.4	7.4	13.4	16.4	0.8	1"	1/2"	5.9	13.7	15.7	5.8	11.6	13.6	2.8
	cm.	57.2	160.0	48.8	6.1	18.8	34.0	41.7	2.0	Swivel	Female	15.0	34.8	39.9	14.7	29.5	34.5	7.1
042-048	in.	25.5	72.0	21.2	2.2	7.2	15.8	18.8	0.8	1"	1/2"	5.9	13.7	15.7	5.8	13.7	15.7	2.5
	cm.	64.8	182.9	53.8	5.6	18.3	40.1	47.8	2.0	Swivel	Female	15.0	34.8	39.9	14.7	34.8	39.9	6.4
060	in.	25.5	77.0	21.2	2.2	7.2	15.8	18.8	0.8	1"	1/2"	5.9	13.7	15.7	5.9	13.7	15.7	2.5
	cm.	64.8	195.6	53.8	5.6	18.3	40.1	47.8	2.0	Swivel	Female	15.0	34.8	39.9	15.0	34.8	39.9	6.4
070	in.	25.5	82.0	21.2	2.2	7.2	15.8	18.8	0.8	1"	1/2"	5.9	13.7	15.7	5.9	13.7	15.7	2.5
	cm.	64.8	208.3	53.8	5.6	18.3	40.1	47.8	2.0	Swivel	Female	15.0	34.8	39.9	15.0	34.8	39.9	6.4

Horizontal Models	Discharge Connection duct flange installed (±0.10 in)								Return Connection using deluxe filter rack option (±0.10 in)						Unit Hanger Dimensions				PVC Drain Size
	R	S Supply Height	T Supply Depth	U	V	W	X	Y Return Height	Z Return Depth	AA	BB	CC	DD	EE	FF	GG	HH		
024-036	in.	6.5	9.4	10.5	6.5	2.3	5.7	6.5	16.9	30.5	2.2	2.8	1.0	1.0	21.1	63.4	24.8	n/a	3/4"
	cm.	16.5	23.9	26.7	16.5	5.8	14.5	16.5	42.9	77.5	5.6	7.1	2.5	2.5	53.6	161.0	63.0	n/a	1.9
042-048	in.	4.5	13.4	13.7	4.8	2.8	6.8	7.5	18.7	35.5	2.2	2.8	1.0	1.0	24.1	43.1	27.8	29.3	3/4"
	cm.	11.4	34.0	34.8	12.2	7.1	17.3	19.1	47.5	90.2	5.6	7.1	2.5	2.5	61.2	109.5	70.6	74.4	1.9
060	in.	4.5	13.4	13.7	4.8	2.8	6.8	7.5	18.7	40.5	2.2	2.8	1.0	1.0	24.1	48.1	27.8	29.3	3/4"
	cm.	11.4	34.0	34.8	12.2	7.1	17.3	19.1	47.5	102.9	5.6	7.1	2.5	2.5	61.2	122.2	70.6	74.4	1.9
070	in.	4.5	13.4	13.7	4.8	2.8	6.8	7.5	18.7	45.5	2.2	2.8	1.0	1.0	24.1	53.1	27.8	29.3	3/4"
	cm.	11.4	34.0	34.8	12.2	7.1	17.3	19.1	47.5	115.6	5.6	7.1	2.5	2.5	61.2	134.9	70.6	74.4	1.9

Unit is shipped with 1" filter. The deluxe duct collar/filter rack is field adjustable to accept a 2" filter. The duct collar/filter rack extends 3.2" from unit, and is suitable for duct connections.

1/12/10

Corner Weight Locations

Model	Horizontal Corner Weights					
	Post #1	Post #2	Post #3	Post #4	Total	
024	lb	35	119	81	33	268
	kg	[16]	[54]	[37]	[15]	[122]
030	lb	38	122	86	33	279
	kg	[17]	[55]	[39]	[15]	[127]
036	lb	40	124	88	35	287
	kg	[18]	[56]	[40]	[16]	[130]
042	lb	63	147	87	52	349
	kg	[29]	[67]	[39]	[24]	[158]
048	lb	64	152	89	53	358
	kg	[29]	[69]	[40]	[24]	[162]
060	lb	93	156	81	73	403
	kg	[42]	[71]	[37]	[33]	[183]
070	lb	143	137	124	34	438
	kg	[65]	[62]	[56]	[15]	[199]

10/28/09

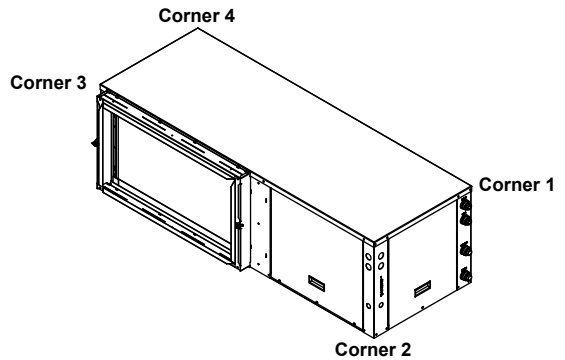

Vertical Dimensional Data

Legend
 AP = Alternate Service Panel
 BP = Blower Service Panel
 CP = Control Access Panel
 CMP = Compressor Service Panel

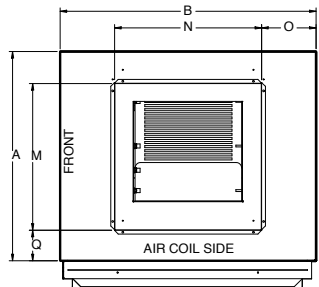

TOP VIEW - RIGHT RETURN

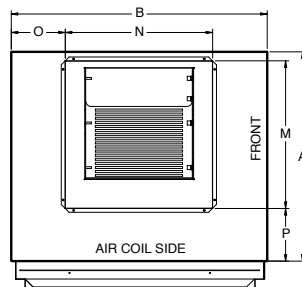

TOP VIEW - LEFT RETURN

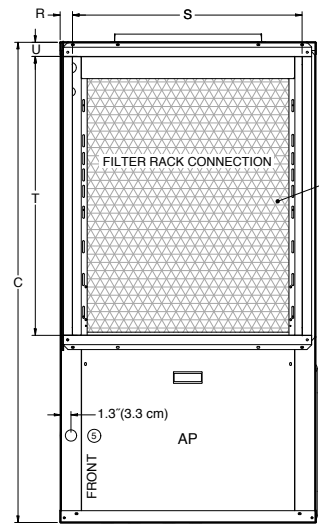

RIGHT VIEW - RIGHT RETURN

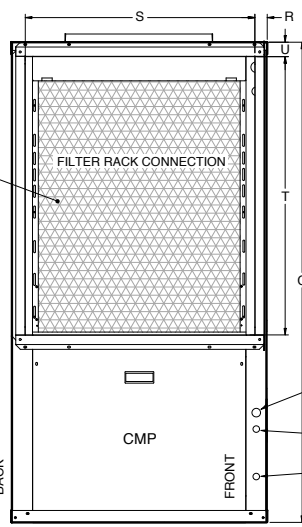

LEFT VIEW - LEFT RETURN

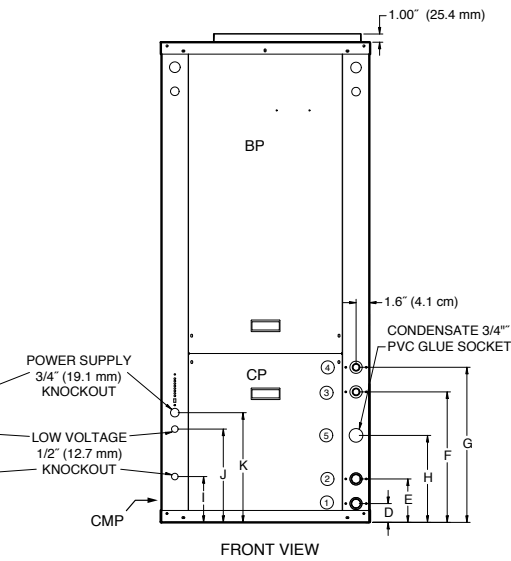
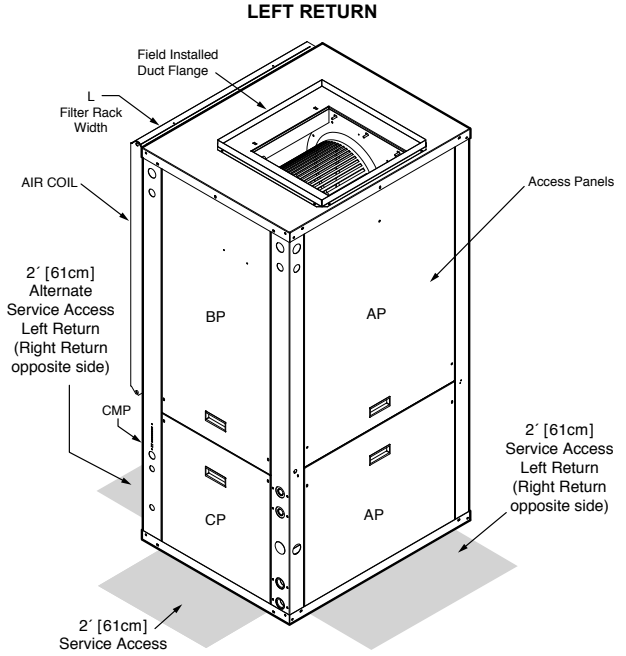

FRONT VIEW

Vertical Topflow Models	Overall Cabinet			Water Connections							Electrical Connections					Discharge Connection duct flange installed (±0.10 in)					Return Connection using std deluxe filter rack (±0.10 in)						
	A	B	C	D	E	F	G	H	Loop	HWG	J	K	L	M	N	P	Q	R	S	T	U	V	W	X	Y	Z	
	Width	Depth	Height	Loop In	Loop Out	HWG In	HWG Out	Condensate	Water FPT	Sweat I.D.	1/2" cond. Low Voltage	1/2" cond. Ext Pump	3/4" cond. Power Supply			Supply Width	Supply Depth				Return Depth	Return Height					
024-	in.	22.3	26.3	44.4	1.9	6.9	13.5	16.4	10.2	1"	1/2"	5.1	10.8	16.5	5.9	3.3	14.0	14.0	6.2	0.8	2.7	2.3	22.0	22.0	1.9	1.0	25.7
036-	cm.	56.6	66.8	112.8	4.8	17.5	34.3	41.7	25.9	Swivel	Female	13.0	27.4	41.9	15.0	8.4	35.6	35.6	15.7	2.0	6.9	5.8	55.9	55.9	4.8	2.5	65.3
042-	in.	25.4	31.4	58.4	2.3	7.3	15.9	18.9	10.6	1"	1/2"	6.5	12.2	17.9	5.9	3.3	18.0	18.0	6.9	1.1	3.8	1.7	28.1	34.0	2.0	1.0	28.7
070-	cm.	64.5	79.8	148.3	5.8	18.5	40.4	48.0	26.9	Swivel	Female	16.5	31.0	45.5	15.0	8.4	45.7	45.7	17.5	2.8	9.7	4.3	71.4	86.4	5.1	2.5	72.9

Condensate is 3/4" PVC female glue socket and is switchable from side to front

Unit shipped with deluxe 1" (field adjustable to 2") duct collar/filter rack extending from unit 3.25" and is suitable for duct connection.

Discharge flange is field installed and extends 1" [25.4mm] from cabinet

1/12/10

Physical Data

Model	024	030	036	042	048	060	070
Compressor (1 each)	Single Speed Scroll						
Factory Charge R-410A, oz [kg] Vertical	52 [1.47]	56 [1.58]	60 [1.70]	74 [2.09]	84 [2.38]	100 [2.83]	104 [2.94]
Factory Charge R-410A, oz [kg] Horizontal	52 [1.47]	56 [1.58]	60 [1.70]	74 [2.09]	84 [2.38]	100 [2.83]	104 [2.94]
Blower Motor & Blower							
Blower Motor Type/Speeds	X13	X13 ECM - 5 Speeds					
	PSC	PSC - 3 Speeds					
Blower Motor - hp [W]	X13	1/2 [373]	1/2 [373]	1/2 [373]	1 [746]	1 [746]	1 [746]
	PSC	1/5 [149]	1/3 [249]	1/2 [373]	1/2 [373]	1/2 [373]	1 [746]
Optional - Oversized Blower Motor - hp [W]	X13	Not Available					
	PSC	1/3 [249]	1/2 [373]	Not Available	3/4 [560]	3/4 [560]	Not Available
Blower Wheel Size (Dia x W), in. [mm]	X13	9 x 7 [229 x 178]	9 x 7 [229 x 178]	9 x 7 [229 x 178]	11 x 10 [279 x 254]	11 x 10 [279 x 254]	11 x 10 [279 x 254]
	PSC	9 x 7 [229 x 178]	9 x 7 [229 x 178]	9 x 7 [229 x 178]	10 x 10 [254 x 254]	10 x 10 [254 x 254]	11 x 10 [279 x 254]
Coax and Water Piping							
Water Connections Size - Swivel - in [mm]	1 [25.4]	1 [25.4]	1 [25.4]	1 [25.4]	1 [25.4]	1 [25.4]	1 [25.4]
HWG Connection Size - Female Sweat (I.D.) - in [mm]	1/2" [12.7]	1/2" [12.7]	1/2" [12.7]	1/2" [12.7]	1/2" [12.7]	1/2" [12.7]	1/2" [12.7]
Coax & Piping Water Volume - gal [l]	.4 [1.4]	0.7 [2.6]	.7 [2.6]	.7 [2.7]	1.0 [3.8]	1.3 [4.9]	1.6 [6.1]
Vertical							
Air Coil Dimensions (H x W), in. [mm]	24 x 20 [610 x 542]	24 x 20 [610 x 542]	28 x 20 [711 x 542]	28 x 25 [711 x 635]	28 x 25 [711 x 635]	32 x 25 [813 x 635]	36 x 25 [914 x 635]
Air Coil Total Face Area, ft ² [m ²]	3.3 [0.310]	3.3 [0.310]	3.9 [0.362]	4.9 [0.451]	4.9 [0.451]	5.6 [0.516]	6.3 [0.581]
Air Coil Tube Size, in [mm]	3/8 [9.5]	3/8 [9.5]	3/8 [9.5]	3/8 [9.5]	3/8 [9.5]	3/8 [9.5]	3/8 [9.5]
Air Coil Number of rows	3	3	3	3	3	3	3
Filter Standard - 1" [24mm] Pleated MERV8 Throwaway, in [mm]	28 x 24 [712 x 610]	28 x 24 [712 x 610]	28 x 24 [712 x 610]	36 x 30 [914 x 762]	36 x 30 [914 x 762]	36 x 30 [914 x 762]	36 x 30 [914 x 762]
Weight - Operating, lb [kg]	267 [121]	282 [128]	308 [140]	351 [159]	388 [176]	430 [195]	435 [197]
Weight - Packaged, lb [kg]	287 [130]	302 [137]	328 [149]	371 [168]	408 [185]	450 [204]	455 [206]
Horizontal							
Air Coil Dimensions (H x W), in. [mm]	18 x 27 [457 x 686]	18 x 27 [457 x 686]	18 x 30 [457 x 762]	20 x 35 [508 x 889]	20 x 35 [508 x 889]	20 x 40 [508 x 1016]	20 x 45 [508 x 1143]
Air Coil Total Face Area, ft ² [m ²]	3.4 [0.316]	3.4 [0.316]	3.9 [0.362]	4.9 [0.451]	4.9 [0.451]	5.6 [0.516]	6.3 [0.581]
Air Coil Tube Size, in [mm]	3/8 [9.5]	3/8 [9.5]	3/8 [9.5]	3/8 [9.5]	3/8 [9.5]	3/8 [9.5]	3/8 [9.5]
Air Coil Number of rows	3	3	3	3	3	3	3
Filter Standard - 1" [25mm] Pleated MERV8 Throwaway, in [mm]	1 - 18 x 32 [457 x 813]	1 - 18 x 32 [457 x 813]	1 - 18 x 32 [457 x 813]	1 - 20 x 37 [686 x 940]	1 - 20 x 37 [686 x 940]	1 - 20 x 20 [508 x 508] 1 - 20 x 22 [508 x 559]	1 - 20 x 25 [508 x 635] 1 - 20 x 22 [508 x 559]
Weight - Operating, lb [kg]	268 [122]	279 [127]	287 [130]	349 [158]	358 [162]	403 [183]	438 [199]
Weight - Packaged, lb [kg]	288 [131]	299 [136]	307 [139]	379 [172]	388 [176]	448 [203]	483 [219]

Auxiliary Heat Ratings

Model	KW			BTU/HR		Min	Y Series Compatibility		
	208V	230V	Stages	208V	230V	CFM	024 - 036	042	048 - 070
EAM(H)5	3.6	4.8	1	12,300	16,300	450	•		
EAM(H)8	5.7	7.6	1	19,400	25,900	550	•		
EAM(H)10	7.2	9.6	1	24,600	32,700	650	•		
EAL(H)10	7.2	9.6	1	24,600	32,700	1100		•	•
EAL(H)15	10.8	14.4	1	36,900	49,100	1250		•	•
EAL(H)20	14.4	19.2	1	49,200	65,500	1500			•

9/18/09

Model	Supply Circuit	Heater Amps		Min Circuit Amp		Max Fuse (USA)		Max Fuse (CAN)		Max CKT BRK	
		208 V	240 V	208 V	240 V	208 V	240 V	208 V	240 V	208 V	240 V
EAM(H)5	Single	17.3	20	26.7	30	30	30	30	30	30	30
EAM(H)8	Single	27.5	31.7	39.3	44.6	40	45	40	45	40	50
EAM(H)10	Single	34.7	40	48.3	55	50	60	50	60	50	60
EAL(H)10	Single	34.7	40	53.3	60	60	60	60	60	60	60
EAL(H)15	Single	52.0	60	75	85	80	90	80	90	70	100
	L1/L2	34.7	40	53.3	60	60	60	60	60	60	60
	L3/L4	17.3	20	21.7	25	25	25	25	25	20	30
EAL(H)20	Single	69.3	80	96.7	110	100	110	100	110	100	100
	L1/L2	34.7	40	53.3	60	60	60	60	60	60	60
	L3/L4	34.7	40	43.3	50	45	50	45	50	40	50

9/18/09

All heaters rated single phase 60 cycle and include unit blower load.
 All fuses type "D" time delay (or HACR circuit breaker in USA)
 Wire length based on one-way measurement with 2% voltage drop
 Wire size based on 60°C (*90°C) copper conductor
 "H" is used in part numbers for horizontal units

Electrical Data

PSC Motor

Model	Compressor Model No.	Rated Voltage	Voltage Min/Max	Compressor				HWG Pump FLA	Ext Loop FLA	Blower Motor FLA	Total Unit FLA	Min Circ Amp	Max Fuse/HACR
				MCC	RLA	LRA	LRA**						
024	ZP20K5E-PFV	208-230/60/1	187/253	21.0	13.5	58.3	21.0	0.4	5.4	1.2	20.5	23.9	35
024*	ZP20K5E-PFV	208-230/60/1	187/253	21.0	13.5	58.3	21.0	0.4	5.4	1.5	20.8	24.2	35
030	ZP25K5E-PFV	208-230/60/1	187/253	22.0	14.1	73.0	26.0	0.4	5.4	1.5	21.4	24.9	35
030*	ZP25K5E-PFV	208-230/60/1	187/253	22.0	14.1	73.0	26.0	0.4	5.4	2.2	22.1	25.6	35
036	HRH029U1LP6	208-230/60/1	187/253	27.0	17.3	96.7	34.0	0.4	5.4	2.2	25.3	29.6	45
042	HRH034U1LP6	208-230/60/1	187/253	31.0	20.0	115.0	41.0	0.4	5.4	3.5	29.3	34.3	50
042*	HRH034U1LP6	208-230/60/1	187/253	31.0	20.0	115.0	41.0	0.4	5.4	4.6	30.4	35.4	50
048	HRH040U1LP6	208-230/60/1	187/253	32.0	21.0	115.0	41.0	0.4	5.4	3.5	30.3	35.6	50
048*	HRH040U1LP6	208-230/60/1	187/253	32.0	21.0	115.0	41.0	0.4	5.4	4.6	31.4	36.7	50
060	HRH051U1LP6	208-230/60/1	187/253	41.0	26.3	150.0	53.0	0.4	5.4	5.9	38.0	44.6	70
070	HRH056U1LP6	208-230/60/1	187/253	47.0	30.1	145.0	51.0	0.4	5.4	5.9	41.8	49.3	70

HACR circuit breaker in USA only

1/12/10

* With optional high-static PSC motor

** With optional GeoStart™, only available on 208-230/60/1

NOTE: High-static option not available on 036, 060, and 070 model sizes.

X13 ECM Motor

Model	Compressor Model No.	Rated Voltage	Voltage Min/Max	Compressor				HWG Pump FLA	Ext Loop FLA	Blower Motor FLA	Total Unit FLA	Min Circ Amp	Max Fuse/HACR
				MCC	RLA	LRA	LRA**						
024	ZP20K5E-PFV	208-230/60/1	187/253	21.0	13.5	58.3	21.0	0.4	5.4	4.1	23.4	26.8	40
030	ZP25K5E-PFV	208-230/60/1	187/253	22.0	14.1	73.0	26.0	0.4	5.4	4.1	24.0	27.5	40
036	HRH029U1LP6	208-230/60/1	187/253	27.0	17.3	96.7	34.0	0.4	5.4	4.1	27.2	31.5	45
042	HRH034U1LP6	208-230/60/1	187/253	31.0	20.0	115.0	41.0	0.4	5.4	7.6	33.4	38.4	50
048	HRH040U1LP6	208-230/60/1	187/253	32.0	21.0	115.0	41.0	0.4	5.4	7.6	34.4	39.7	60
060	HRH051U1LP6	208-230/60/1	187/253	41.0	26.3	150.0	53.0	0.4	5.4	7.6	39.7	46.3	70
070	HRH056U1LP6	208-230/60/1	187/253	47.0	30.1	145.0	51.0	0.4	5.4	7.6	43.5	51.0	80

HACR circuit breaker in USA only

10/20/09

** With optional GeoStart™, only available on 208-230/60/1

Blower Performance Data

Standard PSC Motor

Model	Blower Spd	Blower Size	Motor HP	Airflow (cfm) at External Static Pressure (in. wg)															
				0.00	0.05	0.10	0.15	0.20	0.25	0.30	0.35	0.40	0.45	0.50	0.60	0.70	0.80	0.90	1.00
024	H	9 x 7	1/5	1065	1045	1030	1005	975	950	925	900	870	835	800	-	-	-	-	-
	M			880	865	850	830	815	795	775	750	725	700	670	-	-	-	-	-
	L			805	790	780	765	745	725	710	685	660	630	600	-	-	-	-	-
030	H	9 x 7	1/3	1120	1100	1070	1050	1040	1030	1020	1010	1000	980	830	-	-	-	-	-
	M			1020	1000	980	960	920	880	860	840	820	790	-	-	-	-	-	-
	L			860	850	840	830	810	800	780	760	740	710	-	-	-	-	-	-
036	H	9 x 7	1/2	1360	1340	1320	1290	1260	1220	1185	1130	1080	1045	1010	910	855	-	-	-
	M			1205	1190	1170	1145	1120	1085	1050	1015	980	940	900	845	-	-	-	-
	L			1070	1060	1050	1035	1020	995	970	940	910	875	840	780	-	-	-	-
042	H	10 x 10	1/2	1705	1685	1665	1645	1625	1595	1565	1530	1500	1450	1405	1260	1140	-	-	-
	M			1485	1475	1465	1445	1430	1410	1390	1350	1315	1260	1210	1110	1010	-	-	-
	L			1180	1165	1150	1135	1120	1090	1060	1030	1000	965	920	855	-	-	-	-
048	H	10 x 10	1/2	1930	1910	1885	1860	1830	1790	1750	1710	1665	1620	1580	1280	1235	-	-	-
	M			1580	1565	1550	1535	1525	1505	1485	1445	1410	1310	1215	1130	1030	-	-	-
	L			1180	1170	1160	1140	1120	1100	1080	1050	1020	970	930	875	-	-	-	-
060	H	11 x 10	1	2360	2330	2300	2270	2240	2215	2190	2160	2130	2095	2060	1985	1920	1855	-	-
	M			2165	2130	2095	2070	2050	2030	2010	1985	1965	1930	1900	1850	1775	1700	-	-
	L			1965	1940	1920	1900	1885	1870	1855	1825	1800	1780	1760	1720	1625	1530	-	-
070	H	11 x 10	1	2450	2435	2420	2395	2370	2340	2310	2280	2250	2225	2200	2040	2000	1950	-	-
	M			2215	2190	2170	2155	2140	2120	2095	2070	2045	2015	1990	1940	1875	1795	-	-
	L			2005	1990	1975	1960	1950	1940	1925	1910	1890	1865	1845	1780	1710	1565	-	-

11/13/09

Factory settings are in Bold

Air flow values are with dry coil and standard filter

For wet coil performance first calculate the face velocity of the air coil (Face Velocity [fpm] = Airflow [cfm] / Face Area [sq ft]).

Then for velocities of 200 fpm reduce the static capability by 0.03 in. wg, 300 fpm by 0.08 in. wg, 400 fpm by 0.12 in. wg, and 500 fpm by 0.16 in. wg.

Optional High Static PSC Motor

Model	Blower Spd	Blower Size	Motor HP	Airflow (cfm) at External Static Pressure (in. wg)															
				0.00	0.05	0.10	0.15	0.20	0.25	0.30	0.35	0.40	0.45	0.50	0.60	0.70	0.80	0.90	1.00
024	H	9 x 7	1/3	1120	1100	1070	1050	1040	1030	1020	1010	1000	980	830	-	-	-	-	-
	M			1020	1000	980	960	920	880	860	840	820	790	-	-	-	-	-	-
	L			860	850	840	830	810	800	780	760	740	710	-	-	-	-	-	-
030	H	9 x 7	1/2	1340	1320	1300	1270	1240	1200	1160	1115	1070	1025	985	880	-	-	-	-
	M			1185	1175	1165	1130	1095	1065	1035	1000	965	920	880	795	-	-	-	-
	L			1050	1040	1030	1015	1000	980	960	925	895	855	815	-	-	-	-	-
042	H	10 x 10	3/4	2095	2080	2060	2020	1980	1950	1920	1880	1840	1780	1725	1550	1335	1120	-	-
	M			1960	1940	1920	1890	1865	1830	1800	1760	1725	1670	1620	1435	1300	-	-	-
	L			1800	1780	1760	1740	1725	1695	1670	1625	1585	1525	1465	1300	1200	-	-	-
048	H	10 x 10	3/4	2095	2080	2060	2020	1980	1950	1920	1880	1840	1780	1725	1550	1335	1120	-	-
	M			1960	1940	1920	1890	1865	1830	1800	1760	1725	1670	1620	1435	1300	-	-	-
	L			1800	1780	1760	1740	1725	1695	1670	1625	1585	1525	1465	1300	1200	-	-	-

11/4/09

Factory settings are in Bold

Air flow values are with dry coil and standard filter

For wet coil performance first calculate the face velocity of the air coil (Face Velocity [fpm] = Airflow [cfm] / Face Area [sq ft]).

Then for velocities of 200 fpm reduce the static capability by 0.03 in. wg, 300 fpm by 0.08 in. wg, 400 fpm by 0.12 in. wg, and 500 fpm by 0.16 in. wg.

Blower Performance Data cont.

X13 ECM Motor

Model	Motor Spd	Motor Tap	Blower Size	Motor HP	Airflow (cfm) at External Static Pressure (in. wg)															
					0.00	0.05	0.10	0.15	0.20	0.25	0.30	0.35	0.40	0.45	0.50	0.60	0.70	0.80	0.90	1.00
024	High	5	9 x 7	1/2	980	960	940	930	920	905	890	875	860	840	820	800	745	-	-	-
	Med High	4			890	878	865	845	825	813	800	785	770	753	735	710	665	-	-	-
	Med	3			830	815	800	788	775	755	735	723	710	690	670	640	600	-	-	-
	Med Low	2			780	760	740	703	665	653	640	620	600	585	570	-	-	-	-	-
	Low	1			625	593	560	535	510	495	480	455	430	410	390	-	-	-	-	-
030	High	5	9 x 7	1/2	1340	1310	1280	1240	1200	1170	1140	1095	1050	1015	980	900	800	-	-	-
	Med High	4			1130	1115	1100	1085	1070	1057	1044	1022	1000	970	940	870	780	-	-	-
	Med	3			1030	1005	980	965	950	935	920	900	880	870	860	830	750	-	-	-
	Med Low	2			960	945	930	915	900	885	870	855	840	825	810	790	740	-	-	-
	Low	1			790	765	740	725	710	690	670	660	650	630	610	580	500	-	-	-
036	High	5	9 x 7	1/2	1370	1345	1320	1285	1250	1220	1190	1158	1125	1085	1045	960	-	-	-	
	Med High	4			1265	1253	1240	1220	1200	1175	1150	1120	1090	1053	1015	-	-	-	-	
	Med	3			1160	1143	1125	1113	1100	1085	1070	1055	1040	1020	1000	-	-	-	-	
	Med Low	2			1110	1095	1080	1065	1050	1038	1025	1008	990	980	970	-	-	-	-	
	Low	1			825	803	780	770	760	740	720	705	690	670	650	-	-	-	-	
042	High	5	11 x 10	1	1840	1825	1810	1790	1770	1745	1720	1700	1680	1660	1640	1600	1570	1530	1480	-
	Med High	4			1730	1713	1695	1670	1645	1623	1600	1575	1550	1535	1520	1480	1440	1390	1350	-
	Med	3			1630	1610	1590	1563	1535	1513	1490	1470	1450	1425	1400	1370	1330	1290	-	-
	Med Low	2			1550	1520	1490	1465	1440	1415	1390	1370	1350	1330	1310	1260	1220	1180	-	-
	Low	1			1380	1340	1300	1275	1250	1225	1200	1175	1150	1125	1100	1030	980	820	-	-
048	High	5	11 x 10	1	2060	2045	2030	2015	2000	1970	1940	1925	1910	1890	1870	1830	1800	1750	1740	-
	Med High	4			1880	1860	1840	1825	1810	1785	1760	1740	1720	1705	1690	1640	1610	1570	1535	-
	Med	3			1790	1770	1750	1730	1710	1685	1660	1640	1620	1600	1580	1550	1510	1460	-	-
	Med Low	2			1670	1650	1630	1605	1580	1555	1530	1510	1490	1470	1450	1410	1370	1340	-	-
	Low	1			1430	1405	1380	1353	1325	1303	1280	1255	1230	1210	1190	1130	1070	925	-	-
060	High	5	11 x 10	1	2400	2360	2330	2315	2300	2290	2285	2275	2265	2250	2230	2200	2165	2110	2080	2030
	Med High	4			2180	2160	2140	2130	2120	2105	2090	2075	2060	2045	2030	2000	1960	1930	1890	1850
	Med	3			2080	2050	2020	2010	2000	1985	1970	1955	1940	1925	1910	1870	1840	1800	1760	1720
	Med Low	2			1930	1920	1910	1893	1875	1863	1850	1833	1815	1798	1780	1740	1700	1660	1620	1590
	Low	1			1750	1735	1720	1698	1675	1658	1640	1620	1600	1583	1565	1525	1490	1450	1410	1350
070	High	5	11 x 10	1	2400	2360	2330	2315	2300	2290	2285	2275	2265	2250	2230	2200	2165	2110	2080	2030
	Med High	4			2180	2160	2140	2130	2120	2105	2090	2075	2060	2045	2030	2000	1960	1930	1890	1850
	Med	3			2080	2050	2020	2010	2000	1985	1970	1955	1940	1925	1910	1870	1840	1800	1760	1720
	Med Low	2			1930	1920	1910	1893	1875	1863	1850	1833	1815	1798	1780	1740	1700	1660	1620	1590
	Low	1			1750	1735	1720	1698	1675	1658	1640	1620	1600	1583	1565	1525	1490	1450	1410	1350

Factory settings are in Bold

Air flow values are with dry coil and standard filter

For wet coil performance first calculate the face velocity of the air coil (Face Velocity [fpm] = Airflow [cfm] / Face Area [sq ft]).

Then for velocities of 200 fpm reduce the static capability by 0.03 in. wg, 300 fpm by 0.08 in. wg, 400 fpm by 0.12 in. wg, and 500 fpm by 0.16 in. wg.

ISO/AHRI rating point on the YS070 will require moving the red wire on the motor to high speed (tap 5) and disconnecting the tan wire from tap 5.

11/13/09

X13 ECM Motor Connections

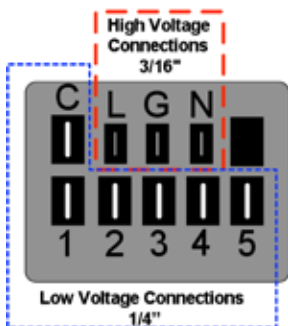

Antifreeze Corrections

Catalog performance can be corrected for antifreeze use. Please use the following table and note the example given.

Antifreeze Type	Antifreeze % by wt	Cooling Capacity	Heating Capacity	Pressure Drop
EWT - degF [DegC]		90 [32.2]	30 [-1.1]	30 [-1.1]
Water	0	1.000	1.000	1.000
Ethylene Glycol	10	0.991	0.973	1.075
	20	0.979	0.943	1.163
	30	0.965	0.917	1.225
	40	0.955	0.890	1.324
	50	0.943	0.865	1.419
Propylene Glycol	10	0.981	0.958	1.130
	20	0.969	0.913	1.270
	30	0.950	0.854	1.433
	40	0.937	0.813	1.614
	50	0.922	0.770	1.816
Ethanol	10	0.991	0.927	1.242
	20	0.972	0.887	1.343
	30	0.947	0.856	1.383
	40	0.930	0.815	1.523
	50	0.911	0.779	1.639
Methanol	10	0.986	0.957	1.127
	20	0.970	0.924	1.197
	30	0.951	0.895	1.235
	40	0.936	0.863	1.323
	50	0.920	0.833	1.399

Warning: Gray area represents antifreeze concentrations greater than 35% by weight and should be avoided due to the extreme performance penalty they represent.

Antifreeze Correction Example

Antifreeze solution is Propylene Glycol 20% by weight. Determine the corrected heating and cooling performance at 30°F and 90°F respectively as well as pressure drop at 30°F for a Y Series YS024-PSC.

The corrected cooling capacity at 90°F would be: 24,500 MBtuh x 0.969 = 23,741 MBtuh

The corrected heating capacity at 30°F would be: 19,000 MBtuh x 0.913 = 17,347 MBtuh

The corrected pressure drop at 30°F and 6 GPM would be: 10.5 feet of head x 1.270 = 13.34 feet of head

Reference Calculations

Heating Calculations:	Cooling Calculations:
$LWT = EWT - \frac{HE}{GPM \times 500}$	$LWT = EWT + \frac{HR}{GPM \times 500}$
$LAT = EAT + \frac{HC}{CFM \times 1.08}$	$LAT (DB) = EAT (DB) - \frac{SC}{CFM \times 1.08}$
$TH = HC + HWC$	$LC = TC - SC$
	$S/T = \frac{SC}{TC}$

Legend and Notes

ABBREVIATIONS AND DEFINITIONS:

CFM = airflow, cubic feet/minute	HE = total heat of extraction, MBTUH
EWT = entering water temperature, Fahrenheit	HWC = hot water generator capacity, MBTUH
GPM = water flow in gallons/minute	EER = Energy Efficient Ratio = BTU output/Watt input
WPD = water pressure drop, PSI and feet of water	COP = Coefficient of Performance = BTU output/BTU input
EAT = entering air temperature, Fahrenheit (dry bulb/wet bulb)	LWT = leaving water temperature, °F
HC = air heating capacity, MBTUH	LAT = leaving air temperature, °F
TC = total cooling capacity, MBTUH	TH = total heating capacity, MBTUH
SC = sensible cooling capacity, MBTUH	LC = latent cooling capacity, MBTUH
KW = total power unit input, kilowatts	S/T = sensible to total cooling ratio
HR = total heat of rejection, MBTUH	

Notes (Refer to Performance Data tables)

- Performance ratings are based on 80°F DB / 67°F WB EAT for cooling and 70°F DB EAT for heating.
- Three flow rates are shown for each unit. The lowest flow rate shown is used for geothermal open loop/well water systems with a minimum of 50°F EWT. The middle flow rate shown is the minimum geothermal closed loop flow rate. The highest flow rate shown is optimum for geothermal closed loop systems and the suggested flow rate for boiler/tower applications.
- The hot water generator numbers are based on a flow rate of 0.4 GPM/ton of rated capacity with an EWT of 90°F.
- Entering water temperatures below 40°F assumes 15% antifreeze solution.
- For non-standard EAT conditions, apply the appropriate correction factors on (Refer to Correction Factor Tables).
- Interpolation between EWT, GPM and CFM data is permissible.
- Pumping power is not included in the Performance Data tables nor are calculations for AHRI/ISO 13256-1.

Operating Limits

Operating Limits	Cooling		Heating	
	(°F)	(°C)	(°F)	(°C)
Air Limits				
Min. Ambient Air	45	7.2	45	7.2
Rated Ambient Air	80	26.7	70	21.1
Max. Ambient Air	100	37.8	85	29.4
Min. Entering Air	50	10.0	40	4.4
Rated Entering Air db/wb	80.6/66.2	27/19	68	20.0
Max. Entering Air db/wb	110/83	43/28.3	80	26.7
Water Limits				
Min. Entering Water	30	-1.1	20	-6.7
Normal Entering Water	50-110	10-43.3	30-70	-1.1
Max. Entering Water	120	48.9	90	32.2

NOTE: Minimum/maximum limits are only for start-up conditions, and are meant for bringing the space up to occupancy temperature. Units are not designed to operate at the minimum/maximum conditions on a regular basis. The operating limits are dependant upon three primary factors: 1) water temperature, 2) return air temperature, and 3) ambient temperature. When any of the factors are at the minimum or maximum levels, the other two factors must be at the normal level for proper and reliable unit operation.

Correction Factor Tables

Cooling Capacity Corrections

Entering Air WB °F	Total Clg Cap	Sensible Cooling Capacity Multipliers - Entering DB °F										Power Input	Heat of Rejection
		60	65	70	75	80	80.6	85	90	95	100		
55	0.898	0.723	0.866	1.048	1.185	*	*	*	*	*	*	0.985	0.913
60	0.912		0.632	0.880	1.078	1.244	1.260	*	*	*	*	0.994	0.927
65	0.967			0.694	0.881	1.079	1.085	1.270	*	*	*	0.997	0.972
66.2	0.983			0.655	0.842	1.040	1.060	1.232	*	*	*	0.999	0.986
67	1.000			0.616	0.806	1.000	1.023	1.193	1.330	*	*	1.000	1.000
70	1.053				0.693	0.879	0.900	1.075	1.250	1.404	*	1.003	1.044
75	1.168					0.687	0.715	0.875	1.040	1.261	1.476	1.007	1.141

NOTE: * Sensible capacity equals total capacity at conditions shown.

11/10/09

Heating Corrections

Ent Air DB °F	Htg Cap	Power	Heat of Ext
45	1.062	0.739	1.158
50	1.050	0.790	1.130
55	1.037	0.842	1.096
60	1.025	0.893	1.064
65	1.012	0.945	1.030
68	1.005	0.976	1.012
70	1.000	1.000	1.000
75	0.987	1.048	0.970
80	0.975	1.099	0.930

11/10/09

Air Flow Corrections

Airflow		Cooling				Heating		
CFM Per Ton of Clg	% of Nominal	Total Cap	Sens Cap	Power	Heat of Rej	Htg Cap	Power	Heat of Ext
240	60	0.922	0.786	0.910	0.920	0.943	1.150	0.893
275	69	0.944	0.827	0.924	0.940	0.958	1.105	0.922
300	75	0.959	0.860	0.937	0.955	0.968	1.078	0.942
325	81	0.971	0.894	0.950	0.967	0.977	1.053	0.959
350	88	0.982	0.929	0.964	0.978	0.985	1.031	0.973
375	94	0.992	0.965	0.982	0.990	0.993	1.014	0.988
400	100	1.000	1.000	1.000	1.000	1.000	1.000	1.000
425	106	1.007	1.034	1.020	1.010	1.007	0.990	1.011
450	113	1.012	1.065	1.042	1.018	1.013	0.983	1.020
475	119	1.017	1.093	1.066	1.026	1.018	0.980	1.028
500	125	1.019	1.117	1.092	1.033	1.023	0.978	1.034
520	130	1.020	1.132	1.113	1.038	1.026	0.975	1.038

11/10/09

Pressure Drop

Model	GPM	Pressure Drop (psi)				
		30°F	50°F	70°F	90°F	110°F
024	3.0	1.1	1.0	0.9	0.8	0.6
	4.5	2.4	2.2	2.1	2.0	1.9
	6.0	4.5	4.4	4.3	4.1	4.0
	8.0	6.7	6.6	6.5	6.3	6.2
030	4.0	0.9	0.8	0.7	0.6	0.5
	6.0	1.9	1.8	1.7	1.6	1.5
	8.0	3.7	3.6	3.5	3.4	3.3
	10.0	4.8	4.7	4.6	4.5	4.4
036	5.0	1.4	1.1	0.9	0.7	0.5
	7.0	2.5	2.3	2.1	1.8	1.6
	9.0	6.0	5.8	5.5	5.3	5.1
	12.0	6.6	6.4	6.2	6.0	5.7
042	5.0	1.5	1.2	0.9	0.5	0.4
	8.0	3.4	3.1	2.8	2.5	2.1
	11.0	7.9	7.5	7.2	6.9	6.6
	14.0	9.1	8.8	8.5	8.2	7.9
048	6.0	2.8	2.6	2.4	2.2	2.0
	9.0	6.5	6.3	6.0	5.8	5.5
	12.0	10.2	9.9	9.6	9.3	9.0
	16.0	12.9	12.6	12.2	11.8	11.4
060	9.0	4.1	3.8	3.6	3.4	3.1
	12.0	7.1	6.7	6.3	5.9	5.6
	15.0	9.6	9.2	8.9	8.6	8.3
	20.0	15.5	14.5	13.3	12.0	10.7
070	12.0	4.0	3.6	3.2	3.0	2.7
	15.0	6.4	6.0	5.6	5.2	4.8
	18.0	8.8	8.4	7.9	7.5	7.1
	24.0	13.6	13.2	12.6	12.0	11.5

4/22/11

YS024 - Performance Data

Single Speed PSC (800 CFM)

EWT °F	Flow gpm	WPD		HEATING - EAT 70°F						COOLING - EAT 80/67°F						
		PSI	FT	HC kBtuh	Power kW	HE kBtuh	LAT °F	COP	HWC kBtuh	TC kBtuh	SC kBtuh	S/T Ratio	Power kW	HR kBtuh	EER	HWC kBtuh
20	3.0	1.2	2.8	Operation not recommended						Operation not recommended						
	4.5	2.4	5.6	Operation not recommended						Operation not recommended						
	6.0	4.6	10.6	15.6	1.68	9.8	86.0	2.72	1.6							
30	3.0	1.1	2.6	Operation not recommended						Operation not recommended						
	4.5	2.4	5.5	18.7	1.74	12.7	89.6	3.14	1.7	27.5	17.4	0.63	1.11	31.2	24.8	---
	6.0	4.5	10.5	19.0	1.76	13.0	90.0	3.16	1.7	27.8	17.7	0.64	1.04	31.4	26.8	---
40	3.0	1.1	2.5	Operation not recommended						Operation not recommended						
	4.5	2.3	5.3	20.5	1.78	14.4	91.7	3.38	1.9	27.6	17.7	0.64	1.20	31.7	22.9	---
	6.0	4.5	10.3	21.1	1.80	15.0	92.4	3.44	1.9	27.9	18.0	0.64	1.14	31.8	24.6	---
50	3.0	1.0	2.3	21.7	1.79	15.6	93.2	3.56	2.1	27.5	18.0	0.65	1.37	32.2	20.1	1.3
	4.5	2.2	5.2	22.5	1.82	16.3	94.0	3.63	2.1	27.8	18.1	0.65	1.30	32.2	21.4	1.2
	6.0	4.4	10.2	23.2	1.84	16.9	94.9	3.70	2.2	28.0	18.2	0.65	1.23	32.2	22.7	1.2
60	3.0	1.0	2.2	24.0	1.83	17.7	95.7	3.84	2.3	26.8	17.7	0.66	1.52	32.0	17.6	1.5
	4.5	2.2	5.0	24.8	1.85	18.5	96.7	3.92	2.4	27.0	17.8	0.66	1.44	32.0	18.8	1.4
	6.0	4.3	10.0	25.6	1.88	19.2	97.6	4.00	2.4	27.3	17.9	0.66	1.36	31.9	20.1	1.4
70	3.0	0.9	2.0	26.2	1.87	19.8	98.3	4.10	2.6	26.1	17.4	0.67	1.67	31.8	15.6	1.8
	4.5	2.1	4.9	27.1	1.89	20.6	99.4	4.20	2.6	26.3	17.5	0.66	1.58	31.7	16.7	1.8
	6.0	4.3	9.9	28.0	1.91	21.5	100.4	4.30	2.7	26.6	17.6	0.66	1.49	31.6	17.8	1.7
80	3.0	0.8	1.9	29.0	1.88	22.6	101.5	4.53	2.9	24.9	16.8	0.68	1.81	31.1	13.7	2.3
	4.5	2.1	4.7	29.7	1.90	23.2	102.4	4.58	2.9	25.2	17.0	0.68	1.73	31.1	14.5	2.2
	6.0	4.2	9.7	30.4	1.92	23.8	103.2	4.64	3.0	25.5	17.1	0.67	1.68	31.2	15.2	2.1
90	3.0	0.8	1.7	31.8	1.88	25.4	104.8	4.95	3.3	23.6	16.2	0.69	2.01	30.5	11.7	2.8
	4.5	2.0	4.6	32.3	1.91	25.8	105.4	4.96	3.4	24.0	16.5	0.69	1.92	30.6	12.5	2.7
	6.0	4.1	9.6	32.8	1.93	26.2	105.9	4.98	3.5	24.5	16.7	0.68	1.86	30.8	13.2	2.5
100	3.0	0.7	1.6	Operation not recommended						Operation not recommended						
	4.5	1.9	4.4	Operation not recommended						22.7	16.0	0.71	2.20	30.2	10.3	3.4
	6.0	4.1	9.4	Operation not recommended						23.0	16.2	0.70	2.13	30.3	10.8	3.2
110	3.0	0.6	1.4	Operation not recommended						Operation not recommended						
	4.5	1.9	4.3	Operation not recommended						21.1	15.4	0.73	2.46	29.5	8.6	4.1
	6.0	4.0	9.3	Operation not recommended						21.5	15.6	0.73	2.39	29.7	9.0	3.9
120	3.0	0.6	1.3	Operation not recommended						Operation not recommended						
	4.5	1.8	4.1	Operation not recommended						19.1	14.8	0.77	2.85	28.9	6.7	4.9
	6.0	3.9	9.1	Operation not recommended						19.6	15.0	0.77	2.77	29.0	7.1	4.6

11/10/09

YS030 - Performance Data

Single Speed PSC (1000 CFM)

EWT °F	Flow gpm	WPD		HEATING - EAT 70°F						COOLING - EAT 80/67°F						
		PSI	FT	HC kBtuh	Power kW	HE kBtuh	LAT °F	COP	HWC kBtuh	TC kBtuh	SC kBtuh	S/T Ratio	Power kW	HR kBtuh	EER	HWC kBtuh
20	4.0	1.0	2.2	Operation not recommended						Operation not recommended						
	6.0	1.9	4.5	Operation not recommended						Operation not recommended						
	8.0	3.8	8.7	20.0	1.90	13.5	86.5	3.09	1.9							
30	4.0	0.9	2.1	Operation not recommended						Operation not recommended						
	6.0	1.9	4.4	21.2	1.96	14.5	87.6	3.16	2.1	30.4	19.3	0.64	1.38	35.1	21.9	---
	8.0	3.7	8.5	22.0	1.98	15.2	88.4	3.26	2.1	30.8	19.7	0.64	1.30	35.2	23.7	---
40	4.0	0.9	2.0	Operation not recommended						Operation not recommended						
	6.0	1.8	4.3	23.9	2.00	17.1	90.1	3.50	2.3	31.3	20.2	0.64	1.41	36.1	22.1	---
	8.0	3.7	8.4	25.0	2.02	18.1	91.1	3.62	2.4	32.4	20.9	0.65	1.40	37.2	23.1	---
50	4.0	0.8	1.9	25.8	2.01	18.9	91.9	3.76	2.5	30.5	19.9	0.65	1.39	35.2	21.9	1.4
	6.0	1.8	4.1	26.9	2.04	19.9	92.9	3.87	2.6	32.3	21.0	0.65	1.45	37.2	22.3	1.3
	8.0	3.6	8.3	27.9	2.06	20.9	93.8	3.97	2.7	34.0	22.1	0.65	1.50	39.1	22.7	1.3
60	4.0	0.8	1.8	29.4	2.05	22.4	95.2	4.20	2.9	30.1	19.7	0.66	1.54	35.3	19.5	1.6
	6.0	1.7	4.0	30.5	2.07	23.4	96.2	4.31	2.9	31.9	20.9	0.66	1.60	37.4	20.0	1.5
	8.0	3.6	8.2	31.6	2.10	24.5	97.3	4.42	3.0	33.8	22.1	0.66	1.65	39.4	20.5	1.4
70	4.0	0.7	1.6	33.0	2.09	25.9	98.6	4.63	3.2	29.6	19.5	0.66	1.69	35.4	17.5	2.0
	6.0	1.7	3.9	34.2	2.11	27.0	99.6	4.74	3.3	31.6	20.8	0.66	1.75	37.6	18.1	1.9
	8.0	3.5	8.1	35.3	2.13	28.0	100.7	4.86	3.4	33.6	22.2	0.66	1.80	39.7	18.7	1.8
80	4.0	0.7	1.5	36.9	2.19	29.4	102.1	4.93	3.6	29.3	19.3	0.66	2.16	36.6	13.6	2.5
	6.0	1.6	3.8	37.8	2.22	30.2	103.0	4.99	3.7	30.7	20.4	0.66	2.06	37.8	15.0	2.4
	8.0	3.5	8.0	38.7	2.24	31.0	103.8	5.06	3.8	32.1	21.5	0.67	1.99	38.8	16.1	2.3
90	4.0	0.6	1.4	40.7	2.29	32.9	105.7	5.21	4.1	29.0	19.0	0.66	2.36	37.0	12.3	3.3
	6.0	1.6	3.7	41.4	2.32	33.4	106.3	5.22	4.2	29.9	20.0	0.67	2.25	37.6	13.3	3.1
	8.0	3.4	7.9	42.0	2.35	34.0	106.9	5.24	4.3	30.5	20.7	0.68	2.18	37.9	14.0	3.0
100	4.0	0.6	1.3	Operation not recommended						Operation not recommended						
	6.0	1.6	3.6	Operation not recommended						27.5	19.7	0.72	2.58	36.3	10.7	3.9
	8.0	3.4	7.8	Operation not recommended						28.0	19.9	0.71	2.50	36.5	11.2	3.7
110	4.0	0.5	1.2	Operation not recommended						Operation not recommended						
	6.0	1.5	3.5	Operation not recommended						24.9	18.7	0.75	2.89	34.7	8.6	4.9
	8.0	3.3	7.6	Operation not recommended						25.4	19.0	0.75	2.81	35.0	9.0	4.5
120	4.0	0.5	1.1	Operation not recommended						Operation not recommended						
	6.0	1.5	3.3	Operation not recommended						21.1	17.2	0.82	3.09	31.7	6.8	5.7
	8.0	3.3	7.5	Operation not recommended						21.6	17.5	0.81	3.00	31.8	7.2	5.4

11/10/09

YS036 - Performance Data

Single Speed PSC (1250 CFM)

EWT °F	Flow gpm	WPD		HEATING - EAT 70°F						COOLING - EAT 80/67°F						
		PSI	FT	HC kBtuh	Power kW	HE kBtuh	LAT °F	COP	HWC kBtuh	TC kBtuh	SC kBtuh	S/T Ratio	Power kW	HR kBtuh	EER	HWC kBtuh
20	5.0	1.5	3.4	Operation not recommended						Operation not recommended						
	7.0	2.6	6.0	Operation not recommended						Operation not recommended						
	9.0	6.1	14.1	23.4	2.43	15.1	86.9	2.83	2.3							
30	5.0	1.4	3.1	Operation not recommended						Operation not recommended						
	7.0	2.5	5.8	27.4	2.46	19.0	90.1	3.27	2.5	35.9	25.1	0.70	1.64	41.5	21.9	---
	9.0	6.0	13.8	28.2	2.51	19.6	90.7	3.29	2.6	36.4	25.6	0.70	1.54	41.7	23.6	---
40	5.0	1.3	2.9	Operation not recommended						Operation not recommended						
	7.0	2.4	5.5	30.8	2.52	22.2	92.8	3.58	2.9	38.7	27.2	0.70	1.74	44.6	22.2	---
	9.0	5.9	13.6	31.9	2.57	23.2	93.7	3.65	2.9	39.2	27.5	0.70	1.66	44.9	23.6	---
50	5.0	1.1	2.6	33.3	2.53	24.6	94.8	3.85	3.1	40.9	29.1	0.71	1.90	47.4	21.5	1.6
	7.0	2.3	5.2	34.5	2.58	25.7	95.8	3.92	3.2	41.5	29.2	0.70	1.84	47.7	22.5	1.5
	9.0	5.8	13.3	35.7	2.62	26.8	96.7	3.99	3.3	42.0	29.4	0.70	1.78	48.1	23.6	1.5
60	5.0	1.0	2.4	37.7	2.60	28.8	98.3	4.25	3.5	39.2	28.5	0.73	2.09	46.4	18.8	2.0
	7.0	2.2	5.0	39.0	2.64	30.0	99.4	4.33	3.6	39.9	28.7	0.72	2.02	46.8	19.7	1.9
	9.0	5.7	13.1	40.2	2.67	31.1	100.4	4.42	3.6	40.5	28.9	0.71	1.96	47.2	20.7	1.8
70	5.0	0.9	2.1	42.1	2.67	33.0	101.9	4.62	3.9	37.6	27.9	0.74	2.28	45.3	16.5	2.5
	7.0	2.1	4.7	43.5	2.70	34.3	103.0	4.73	4.0	38.3	28.2	0.74	2.21	45.8	17.4	2.4
	9.0	5.5	12.8	44.8	2.72	35.5	104.1	4.83	4.1	39.0	28.5	0.73	2.13	46.3	18.3	2.3
80	5.0	0.8	1.8	46.7	2.73	37.4	105.6	5.01	4.4	36.1	27.1	0.75	2.55	44.8	14.1	3.2
	7.0	1.9	4.5	47.7	2.76	38.3	106.4	5.07	4.5	36.7	27.6	0.75	2.43	45.0	15.1	3.0
	9.0	5.4	12.5	48.8	2.79	39.3	107.3	5.13	4.6	37.4	28.0	0.75	2.36	45.4	15.9	2.9
90	5.0	0.7	1.6	51.2	2.79	41.7	109.3	5.39	4.9	34.5	26.3	0.76	2.79	44.1	12.4	3.9
	7.0	1.8	4.2	52.0	2.83	42.4	109.9	5.40	5.1	35.1	27.0	0.77	2.67	44.2	13.2	3.7
	9.0	5.3	12.3	52.8	2.86	43.1	110.5	5.41	5.2	35.8	27.5	0.77	2.58	44.6	13.9	3.6
100	5.0	0.6	1.3	Operation not recommended						Operation not recommended						
	7.0	1.7	4.0	Operation not recommended						33.3	26.4	0.79	2.98	43.5	11.2	4.6
	9.0	5.2	12.0	Operation not recommended						33.8	26.6	0.79	2.89	43.6	11.7	4.4
110	5.0	0.5	1.1	Operation not recommended						Operation not recommended						
	7.0	1.6	3.7	Operation not recommended						31.2	25.3	0.81	3.28	42.4	9.5	5.7
	9.0	5.1	11.8	Operation not recommended						31.8	25.7	0.81	3.19	42.7	10.0	5.4
120	5.0	0.4	0.8	Operation not recommended						Operation not recommended						
	7.0	1.5	3.5	Operation not recommended						26.5	22.7	0.85	3.61	38.8	7.4	6.8
	9.0	5.0	11.5	Operation not recommended						27.1	23.0	0.85	3.50	39.0	7.7	6.4

11/10/09

YS042 - Performance Data

Single Speed PSC (1400 CFM)

EWT °F	Flow gpm	WPD		HEATING - EAT 70°F						COOLING - EAT 80/67°F						
		PSI	FT	HC kBtuh	Power kW	HE kBtuh	LAT °F	COP	HWC kBtuh	TC kBtuh	SC kBtuh	S/T Ratio	Power kW	HR kBtuh	EER	HWC kBtuh
20	5.0	1.6	3.8	Operation not recommended						Operation not recommended						
	8.0	3.6	8.2	Operation not recommended						Operation not recommended						
	11.0	8.0	18.5	27.0	2.81	17.4	85.9	2.82	3.5							
30	5.0	1.5	3.4	Operation not recommended						Operation not recommended						
	8.0	3.4	7.8	30.0	2.82	20.4	87.8	3.12	3.7	43.6	31.7	0.73	1.93	50.2	22.6	---
	11.0	7.9	18.1	31.0	2.86	21.2	88.5	3.18	3.8	44.2	32.3	0.73	1.81	50.4	24.4	---
40	5.0	1.3	3.0	Operation not recommended						Operation not recommended						
	8.0	3.2	7.5	33.4	2.88	23.5	90.1	3.40	4.0	45.7	32.7	0.72	2.06	52.7	22.1	---
	11.0	7.7	17.8	34.8	2.91	24.8	91.0	3.50	4.1	46.3	33.2	0.72	1.95	53.0	23.7	---
50	5.0	1.2	2.7	35.5	2.92	25.5	91.5	3.56	4.4	47.1	33.4	0.71	2.31	55.0	20.4	2.4
	8.0	3.1	7.1	37.0	2.94	27.0	92.5	3.69	4.5	47.8	33.8	0.71	2.20	55.3	21.7	2.4
	11.0	7.5	17.4	38.5	2.96	28.4	93.5	3.81	4.7	48.4	34.1	0.70	2.09	55.5	23.2	2.3
60	5.0	1.0	2.3	39.9	2.99	29.7	94.4	3.91	5.0	46.0	32.8	0.71	2.57	54.8	17.9	3.0
	8.0	2.9	6.7	41.4	3.01	31.1	95.3	4.03	5.1	47.0	33.1	0.70	2.43	55.3	19.3	2.8
	11.0	7.4	17.0	42.9	3.03	32.5	96.3	4.15	5.3	48.0	33.5	0.70	2.30	55.8	20.9	2.7
70	5.0	0.9	2.0	44.2	3.05	33.8	97.2	4.25	5.6	44.9	32.2	0.72	2.82	54.5	15.9	3.8
	8.0	2.8	6.4	45.7	3.07	35.2	98.2	4.36	5.7	46.3	32.5	0.70	2.66	55.3	17.4	3.6
	11.0	7.2	16.7	47.2	3.09	36.7	99.2	4.48	5.9	47.6	32.8	0.69	2.50	56.1	19.0	3.4
80	5.0	0.7	1.6	49.4	3.11	38.8	100.7	4.65	6.3	43.4	31.6	0.73	3.02	53.8	14.4	4.8
	8.0	2.6	6.0	50.6	3.15	39.8	101.5	4.71	6.5	44.4	31.9	0.72	2.88	54.3	15.4	4.5
	11.0	7.1	16.3	51.8	3.18	40.9	102.2	4.78	6.7	45.6	32.1	0.70	2.79	55.1	16.3	4.3
90	5.0	0.5	1.2	54.6	3.18	43.8	104.1	5.04	7.1	42.0	31.0	0.74	3.34	53.4	12.6	6.0
	8.0	2.5	5.7	55.5	3.22	44.5	104.7	5.05	7.3	42.6	31.2	0.73	3.18	53.5	13.4	5.7
	11.0	6.9	16.0	56.3	3.26	45.2	105.2	5.06	7.5	43.5	31.4	0.72	3.08	54.0	14.1	5.5
100	5.0	0.4	0.9	Operation not recommended						Operation not recommended						
	8.0	2.3	5.3	Operation not recommended						39.8	30.2	0.76	3.55	52.0	11.2	7.1
	11.0	6.8	15.6	Operation not recommended						40.5	30.5	0.75	3.44	52.2	11.8	6.8
110	5.0	0.4	0.9	Operation not recommended						Operation not recommended						
	8.0	2.1	4.9	Operation not recommended						36.7	29.1	0.79	3.91	50.0	9.4	8.6
	11.0	6.6	15.2	Operation not recommended						37.4	29.5	0.79	3.80	50.4	9.8	8.3
120	5.0	0.4	0.9	Operation not recommended						Operation not recommended						
	8.0	2.0	4.6	Operation not recommended						33.2	28.2	0.85	4.55	48.7	7.3	10.4
	11.0	6.5	14.9	Operation not recommended						33.9	28.6	0.84	4.42	49.0	7.7	10.0

11/10/09

YS048 - Performance Data

Single Speed PSC (1600 CFM)

EWT °F	Flow gpm	WPD		HEATING - EAT 70°F						COOLING - EAT 80/67°F						
		PSI	FT	HC kBtuh	Power kW	HE kBtuh	LAT °F	COP	HWC kBtuh	TC kBtuh	SC kBtuh	S/T Ratio	Power kW	HR kBtuh	EER	HWC kBtuh
20	6.0	2.2	5.1	Operation not recommended						Operation not recommended						
	9.0	4.4	10.0	Operation not recommended						Operation not recommended						
	12.0	6.8	15.8	30.8	3.32	19.5	87.0	2.72	4.6	Operation not recommended						
30	6.0	2.0	4.7	Operation not recommended						Operation not recommended						
	9.0	4.2	9.6	35.3	3.31	24.0	89.8	3.12	4.9	50.3	31.3	0.62	2.33	58.3	21.6	---
	12.0	6.7	15.5	35.8	3.35	24.4	90.1	3.13	5.0	51.0	31.9	0.63	2.19	58.5	23.3	---
40	6.0	1.9	4.3	Operation not recommended						Operation not recommended						
	9.0	4.0	9.2	40.1	3.44	28.4	92.8	3.41	5.4	53.1	34.8	0.65	2.52	61.7	21.1	---
	12.0	6.5	15.0	41.9	3.51	30.0	93.9	3.51	5.5	54.0	35.5	0.66	2.39	62.2	22.6	---
50	6.0	1.7	3.9	42.9	3.50	31.0	94.5	3.60	5.9	54.9	37.4	0.68	2.84	64.6	19.3	2.9
	9.0	3.8	8.8	45.5	3.58	33.3	96.1	3.73	6.1	56.0	38.3	0.68	2.72	65.2	20.6	2.8
	12.0	6.3	14.6	48.1	3.66	35.6	97.7	3.85	6.2	57.0	39.1	0.69	2.59	65.8	22.0	2.7
60	6.0	1.5	3.5	49.5	3.67	37.0	98.6	3.96	6.7	54.5	37.4	0.69	3.14	65.2	17.4	3.5
	9.0	3.6	8.4	52.2	3.73	39.5	100.2	4.11	6.8	55.4	38.0	0.69	2.99	65.6	18.5	3.4
	12.0	6.1	14.1	54.9	3.79	42.0	101.9	4.25	7.0	56.2	38.6	0.69	2.85	65.9	19.8	3.2
70	6.0	1.3	3.0	56.1	3.83	43.0	102.6	4.29	7.5	54.1	37.3	0.69	3.43	65.8	15.8	4.5
	9.0	3.5	8.0	58.9	3.87	45.7	104.4	4.46	7.7	54.8	37.7	0.69	3.27	65.9	16.8	4.3
	12.0	5.9	13.7	61.7	3.91	48.4	106.1	4.63	7.9	55.4	38.2	0.69	3.10	66.0	17.9	4.0
80	6.0	1.1	2.6	61.3	3.91	47.9	105.8	4.59	8.4	51.4	35.8	0.70	3.71	64.0	13.9	5.6
	9.0	3.3	7.6	63.2	3.96	49.7	107.0	4.68	8.6	52.1	36.4	0.70	3.54	64.2	14.7	5.3
	12.0	5.8	13.3	65.2	4.01	51.5	108.2	4.77	8.9	52.9	36.9	0.70	3.43	64.6	15.5	5.1
90	6.0	1.0	2.2	66.5	4.00	52.9	109.1	4.88	9.4	48.7	34.3	0.70	4.06	62.5	12.0	7.0
	9.0	3.1	7.1	67.5	4.05	53.7	109.7	4.89	9.7	49.4	35.0	0.71	3.87	62.7	12.8	6.7
	12.0	5.6	12.9	68.6	4.10	54.6	110.3	4.90	10.1	50.4	35.6	0.70	3.75	63.2	13.5	6.4
100	6.0	0.8	1.8	Operation not recommended						Operation not recommended						
	9.0	2.9	6.7	Operation not recommended						46.7	34.3	0.74	4.37	61.6	10.7	8.4
	12.0	5.4	12.5	Operation not recommended						47.4	34.6	0.73	4.23	61.8	11.2	8.0
110	6.0	0.6	1.4	Operation not recommended						Operation not recommended						
	9.0	2.7	6.3	Operation not recommended						43.4	33.2	0.76	4.83	59.9	9.0	10.3
	12.0	5.2	12.1	Operation not recommended						44.3	33.7	0.76	4.70	60.4	9.4	9.7
120	6.0	0.4	1.0	Operation not recommended						Operation not recommended						
	9.0	2.6	5.9	Operation not recommended						40.1	32.0	0.80	5.40	58.5	7.4	12.4
	12.0	5.0	11.6	Operation not recommended						41.0	32.5	0.79	5.24	58.8	7.8	11.8

4/22/11

YS060 - Performance Data

Single Speed PSC (2000 CFM)

EWT °F	Flow gpm	WPD		HEATING - EAT 70°F						COOLING - EAT 80/67°F						
		PSI	FT	HC kBtuh	Power kW	HE kBtuh	LAT °F	COP	HWC kBtuh	TC kBtuh	SC kBtuh	S/T Ratio	Power kW	HR kBtuh	EER	HWC kBtuh
20	9.0	3.8	8.7	Operation not recommended						Operation not recommended						
	12.0	6.3	14.5	Operation not recommended						Operation not recommended						
	15.0	9.7	22.5	41.9	4.06	28.0	87.4	3.02	5.5							
30	9.0	3.6	8.4	Operation not recommended						Operation not recommended						
	12.0	6.1	14.1	43.8	3.99	30.2	88.3	3.22	5.9	72.0	49.1	0.68	2.96	82.1	24.3	---
	15.0	9.6	22.2	46.5	4.11	32.5	89.5	3.31	6.1	73.0	50.0	0.68	2.78	82.5	26.3	---
40	9.0	3.5	8.0	Operation not recommended						Operation not recommended						
	12.0	6.0	13.7	49.7	4.12	35.6	91.0	3.53	6.6	70.8	48.8	0.69	3.11	81.4	22.8	---
	15.0	9.4	21.7	52.2	4.22	37.8	92.2	3.63	6.7	71.8	49.5	0.69	2.97	81.9	24.2	---
50	9.0	3.3	7.6	54.6	4.20	40.3	93.3	3.81	7.1	68.5	48.0	0.70	3.34	79.9	20.5	3.9
	12.0	5.8	13.4	56.2	4.26	41.7	94.0	3.87	7.3	69.5	48.5	0.70	3.25	80.6	21.4	3.7
	15.0	9.2	21.3	57.8	4.32	43.1	94.8	3.92	7.5	70.5	48.9	0.69	3.16	81.3	22.3	3.5
60	9.0	3.1	7.3	62.2	4.35	47.3	96.8	4.19	8.0	67.3	47.0	0.70	3.64	79.7	18.5	4.8
	12.0	5.6	13.0	64.3	4.41	49.3	97.8	4.28	8.3	68.2	47.6	0.70	3.54	80.3	19.3	4.6
	15.0	9.1	21.0	66.4	4.46	51.2	98.8	4.36	8.5	69.1	48.3	0.70	3.45	80.9	20.1	4.4
70	9.0	3.0	6.9	69.8	4.50	54.4	100.3	4.54	9.0	66.0	46.0	0.70	3.93	79.4	16.8	6.0
	12.0	5.5	12.6	72.4	4.55	56.9	101.5	4.66	9.3	66.9	46.8	0.70	3.83	79.9	17.5	5.7
	15.0	8.9	20.6	75.0	4.60	59.3	102.7	4.78	9.5	67.7	47.6	0.70	3.73	80.4	18.2	5.4
80	9.0	2.8	6.5	76.2	4.59	60.6	103.3	4.87	10.2	62.2	45.0	0.72	4.45	77.4	14.0	7.6
	12.0	5.3	12.3	78.2	4.65	62.3	104.2	4.93	10.5	63.1	45.7	0.72	4.25	77.6	14.9	7.2
	15.0	8.8	20.2	80.1	4.70	64.1	105.1	5.00	10.7	64.1	46.3	0.72	4.11	78.1	15.6	6.8
90	9.0	2.7	6.1	82.7	4.68	66.8	106.3	5.18	11.4	58.4	43.9	0.75	4.86	75.0	12.0	9.5
	12.0	5.2	11.9	84.0	4.74	67.8	106.9	5.19	11.8	59.3	44.6	0.75	4.64	75.2	12.8	9.0
	15.0	8.6	19.9	85.3	4.80	68.9	107.5	5.21	12.2	60.5	45.0	0.74	4.49	75.9	13.5	8.6
100	9.0	2.5	5.8	Operation not recommended						Operation not recommended						
	12.0	5.0	11.5	Operation not recommended						56.1	43.4	0.77	5.15	73.7	10.9	11.2
	15.0	8.4	19.5	Operation not recommended						57.0	43.7	0.77	4.99	74.0	11.4	10.6
110	9.0	2.3	5.4	Operation not recommended						Operation not recommended						
	12.0	4.8	11.2	Operation not recommended						52.3	41.8	0.80	5.63	71.6	9.3	13.8
	15.0	8.3	19.1	Operation not recommended						53.4	42.4	0.79	5.48	72.1	9.7	13.1
120	9.0	2.2	5.0	Operation not recommended						Operation not recommended						
	12.0	4.7	10.8	Operation not recommended						48.0	39.9	0.83	6.25	69.3	7.7	16.6
	15.0	8.1	18.8	Operation not recommended						49.0	40.5	0.83	6.07	69.7	8.1	15.9

YS070 - Performance Data

Single Speed PSC (2200 CFM)

EWT °F	Flow gpm	WPD		HEATING - EAT 70°F						COOLING - EAT 80/67°F						
		PSI	FT	HC kBtuh	Power kW	HE kBtuh	LAT °F	COP	HWC kBtuh	TC kBtuh	SC kBtuh	S/T Ratio	Power kW	HR kBtuh	EER	HWC kBtuh
20	12.0	4.3	9.8	Operation not recommended						Operation not recommended						
	15.0	5.6	13.0	Operation not recommended						Operation not recommended						
	18.0	9.0	20.8	46.0	4.98	29.0	87.4	2.71	6.5	Operation not recommended						
30	12.0	4.1	9.4	Operation not recommended						Operation not recommended						
	15.0	5.9	13.6	52.0	4.92	35.2	89.9	3.09	7.0	73.0	46.1	0.63	3.30	84.3	22.1	---
	18.0	8.8	20.3	53.7	5.06	36.4	90.6	3.11	7.3	74.0	47.0	0.64	3.10	84.6	23.9	---
40	12.0	3.8	8.8	Operation not recommended						Operation not recommended						
	15.0	5.2	12.0	58.4	5.10	41.0	92.6	3.35	7.8	74.6	49.3	0.66	3.49	86.5	21.4	---
	18.0	8.6	19.8	60.9	5.20	43.1	93.6	3.43	8.0	76.1	50.5	0.66	3.36	87.5	22.7	---
50	12.0	3.6	8.4	62.8	5.25	44.9	94.4	3.51	8.5	74.2	51.0	0.69	3.74	87.0	19.8	4.3
	15.0	5.0	11.5	65.4	5.29	47.4	95.5	3.62	8.7	76.2	52.5	0.69	3.68	88.7	20.7	4.1
	18.0	8.4	19.3	68.0	5.33	49.8	96.6	3.74	8.9	78.2	54.0	0.69	3.61	90.5	21.7	3.9
60	12.0	3.4	7.9	71.9	5.46	53.3	98.3	3.86	9.5	71.6	50.0	0.70	4.08	85.5	17.6	5.2
	15.0	4.8	11.0	73.9	5.49	55.2	99.1	3.95	9.8	73.3	51.3	0.70	4.00	87.0	18.3	4.9
	18.0	8.2	18.8	76.0	5.52	57.2	100.0	4.03	10.1	75.1	52.5	0.70	3.92	88.4	19.1	4.8
70	12.0	3.2	7.4	81.0	5.66	61.7	102.1	4.19	10.7	69.0	49.0	0.71	4.41	84.0	15.6	6.6
	15.0	4.6	10.5	82.5	5.69	63.1	102.7	4.25	11.0	70.5	50.0	0.71	4.32	85.2	16.3	6.3
	18.0	7.9	18.3	84.0	5.71	64.5	103.3	4.31	11.3	71.9	51.0	0.71	4.23	86.4	17.0	6.0
80	12.0	3.0	6.9	89.7	5.82	69.8	105.8	4.52	12.1	65.3	47.4	0.73	5.04	82.5	12.9	8.3
	15.0	4.4	10.0	91.2	5.88	71.2	106.4	4.55	12.4	66.5	48.3	0.73	4.81	82.9	13.8	7.9
	18.0	7.7	17.9	92.7	5.93	72.5	107.0	4.59	12.8	67.9	49.0	0.72	4.66	83.8	14.6	7.5
90	12.0	2.8	6.4	98.4	5.99	78.0	109.4	4.82	13.6	61.6	45.8	0.74	5.50	80.4	11.2	10.4
	15.0	4.1	9.5	99.9	6.07	79.2	110.1	4.83	14.0	62.5	46.6	0.75	5.25	80.4	11.9	9.9
	18.0	7.5	17.3	101.5	6.14	80.5	110.7	4.84	14.4	63.8	47.0	0.74	5.08	81.1	12.6	9.4
100	12.0	2.5	5.9	Operation not recommended						Operation not recommended						
	15.0	3.9	9.1	Operation not recommended						59.7	44.9	0.75	5.83	79.6	10.2	12.4
	18.0	7.3	16.9	Operation not recommended						60.6	45.3	0.75	5.65	79.8	10.7	11.7
110	12.0	2.3	5.4	Operation not recommended						Operation not recommended						
	15.0	3.7	8.5	Operation not recommended						56.2	42.9	0.76	6.38	78.0	8.8	15.1
	18.0	7.1	16.4	Operation not recommended						57.4	43.5	0.76	6.21	78.5	9.2	14.3
120	12.0	2.1	4.9	Operation not recommended						Operation not recommended						
	15.0	3.5	8.1	Operation not recommended						51.9	41.4	0.80	7.09	76.0	7.3	18.2
	18.0	6.9	15.9	Operation not recommended						53.0	42.0	0.79	6.88	76.4	7.7	17.3

4/22/11

YS024 - Performance Data

Single Speed X13 ECM (800 CFM)

EWT °F	Flow gpm	WPD		HEATING - EAT 70°F						COOLING - EAT 80/67°F						
		PSI	FT	HC kBtuh	Power kW	HE kBtuh	LAT °F	COP	HWC kBtuh	TC kBtuh	SC kBtuh	S/T Ratio	Power kW	HR kBtuh	EER	HWC kBtuh
20	3.0	1.2	2.8	Operation not recommended						Operation not recommended						
	4.5	2.4	5.6	Operation not recommended						Operation not recommended						
	6.0	4.6	10.6	15.6	1.53	10.3	86.0	2.98	1.6							
30	3.0	1.1	2.6	Operation not recommended						Operation not recommended						
	4.5	2.4	5.5	18.7	1.59	13.2	89.6	3.44	1.7	27.5	17.4	0.63	0.94	30.7	29.1	---
	6.0	4.5	10.5	19.0	1.61	13.5	90.0	3.46	1.7	27.8	17.7	0.64	0.89	30.9	31.5	---
40	3.0	1.1	2.5	Operation not recommended						Operation not recommended						
	4.5	2.3	5.3	20.5	1.63	14.9	91.7	3.69	1.9	27.6	17.7	0.64	1.04	31.2	26.4	---
	6.0	4.5	10.3	21.1	1.65	15.5	92.4	3.75	1.9	27.9	18.0	0.64	0.98	31.3	28.5	---
50	3.0	1.0	2.3	21.7	1.64	16.1	93.2	3.88	2.1	27.5	18.0	0.65	1.22	31.7	22.6	1.3
	4.5	2.2	5.2	22.5	1.66	16.8	94.0	3.96	2.1	27.8	18.1	0.65	1.15	31.7	24.2	1.2
	6.0	4.4	10.2	23.2	1.69	17.4	94.9	4.03	2.2	28.0	18.2	0.65	1.08	31.6	26.0	1.2
60	3.0	1.0	2.2	24.0	1.68	18.2	95.7	4.17	2.3	26.8	17.7	0.66	1.37	31.5	19.6	1.5
	4.5	2.2	5.0	24.8	1.70	19.0	96.7	4.26	2.4	27.0	17.8	0.66	1.29	31.4	21.0	1.4
	6.0	4.3	10.0	25.6	1.72	19.7	97.6	4.35	2.4	27.3	17.9	0.66	1.21	31.4	22.6	1.4
70	3.0	0.9	2.0	26.2	1.72	20.3	98.3	4.45	2.6	26.1	17.4	0.67	1.52	31.3	17.2	1.8
	4.5	2.1	4.9	27.1	1.74	21.1	99.4	4.56	2.6	26.3	17.5	0.66	1.43	31.2	18.4	1.8
	6.0	4.3	9.9	28.0	1.76	22.0	100.4	4.66	2.7	26.6	17.6	0.66	1.34	31.1	19.8	1.7
80	3.0	0.8	1.9	29.0	1.73	23.1	101.5	4.91	2.9	24.9	16.8	0.68	1.65	30.5	15.0	2.3
	4.5	2.1	4.7	29.7	1.75	23.7	102.4	4.97	2.9	25.2	17.0	0.68	1.58	30.5	16.0	2.2
	6.0	4.2	9.7	30.4	1.77	24.3	103.2	5.03	3.0	25.5	17.1	0.67	1.53	30.7	16.7	2.1
90	3.0	0.8	1.7	31.8	1.74	25.9	104.8	5.37	3.3	23.6	16.2	0.69	1.85	29.9	12.8	2.8
	4.5	2.0	4.6	32.3	1.76	26.3	105.4	5.38	3.4	24.0	16.5	0.69	1.77	30.0	13.6	2.7
	6.0	4.1	9.6	32.8	1.78	26.7	105.9	5.40	3.5	24.5	16.7	0.68	1.71	30.3	14.3	2.5
100	3.0	0.7	1.6	Operation not recommended						Operation not recommended						
	4.5	1.9	4.4	Operation not recommended						22.7	16.0	0.71	2.04	29.6	11.1	3.4
	6.0	4.1	9.4	Operation not recommended						23.0	16.2	0.70	1.97	29.7	11.7	3.2
110	3.0	0.6	1.4	Operation not recommended						Operation not recommended						
	4.5	1.9	4.3	Operation not recommended						21.1	15.4	0.73	2.30	29.0	9.2	4.1
	6.0	4.0	9.3	Operation not recommended						21.5	15.6	0.73	2.24	29.2	9.6	3.9
120	3.0	0.6	1.3	Operation not recommended						Operation not recommended						
	4.5	1.8	4.1	Operation not recommended						19.1	14.8	0.77	2.70	28.4	7.1	4.9
	6.0	3.9	9.1	Operation not recommended						19.6	15.0	0.77	2.63	28.5	7.4	4.6

YS030 - Performance Data

Single Speed X13 ECM (1000 CFM)

EWT °F	Flow gpm	WPD		HEATING - EAT 70°F						COOLING - EAT 80/67°F						
		PSI	FT	HC kBtuh	Power kW	HE kBtuh	LAT °F	COP	HWC kBtuh	TC kBtuh	SC kBtuh	S/T Ratio	Power kW	HR kBtuh	EER	HWC kBtuh
20	4.0	1.0	2.2	Operation not recommended						Operation not recommended						
	6.0	1.9	4.5	Operation not recommended						Operation not recommended						
	8.0	3.8	8.7	20.0	1.70	14.2	86.5	3.45	1.9							
30	4.0	0.9	2.1	Operation not recommended						Operation not recommended						
	6.0	1.9	4.4	21.2	1.76	15.1	87.6	3.52	2.1	30.4	19.3	0.64	1.17	34.4	25.9	---
	8.0	3.7	8.5	22.0	1.78	15.9	88.4	3.62	2.1	30.8	19.7	0.64	1.10	34.6	28.0	---
40	4.0	0.9	2.0	Operation not recommended						Operation not recommended						
	6.0	1.8	4.3	23.9	1.80	17.7	90.1	3.89	2.3	31.3	20.2	0.64	1.21	35.4	25.9	---
	8.0	3.7	8.4	25.0	1.82	18.7	91.1	4.02	2.4	32.4	20.9	0.65	1.20	36.5	27.0	---
50	4.0	0.8	1.9	25.8	1.81	19.6	91.9	4.18	2.5	30.5	19.9	0.65	1.19	34.6	25.6	1.4
	6.0	1.8	4.1	26.9	1.84	20.6	92.9	4.29	2.6	32.3	21.0	0.65	1.25	36.5	25.9	1.3
	8.0	3.6	8.3	27.9	1.86	21.6	93.8	4.40	2.7	34.0	22.1	0.65	1.30	38.4	26.2	1.3
60	4.0	0.8	1.8	29.4	1.85	23.1	95.2	4.66	2.9	30.1	19.7	0.66	1.34	34.6	22.4	1.6
	6.0	1.7	4.0	30.5	1.87	24.1	96.2	4.77	2.9	31.9	20.9	0.66	1.40	36.7	22.9	1.5
	8.0	3.6	8.2	31.6	1.90	25.1	97.3	4.89	3.0	33.8	22.1	0.66	1.45	38.7	23.3	1.4
70	4.0	0.7	1.6	33.0	1.89	26.6	98.6	5.12	3.2	29.6	19.5	0.66	1.49	34.7	19.9	2.0
	6.0	1.7	3.9	34.2	1.91	27.6	99.6	5.24	3.3	31.6	20.8	0.66	1.55	36.9	20.5	1.9
	8.0	3.5	8.1	35.3	1.93	28.7	100.7	5.36	3.4	33.6	22.2	0.66	1.60	39.1	21.0	1.8
80	4.0	0.7	1.5	36.9	1.99	30.1	102.1	5.42	3.6	29.3	19.3	0.66	1.94	35.9	15.1	2.5
	6.0	1.6	3.8	37.8	2.02	30.9	103.0	5.49	3.7	30.7	20.4	0.66	1.85	37.1	16.6	2.4
	8.0	3.5	8.0	38.7	2.04	31.7	103.8	5.55	3.8	32.1	21.5	0.67	1.79	38.2	17.9	2.3
90	4.0	0.6	1.4	40.7	2.10	33.6	105.7	5.70	4.1	29.0	19.0	0.66	2.14	36.3	13.5	3.3
	6.0	1.6	3.7	41.4	2.12	34.1	106.3	5.71	4.2	29.9	20.0	0.67	2.05	36.9	14.6	3.1
	8.0	3.4	7.9	42.0	2.15	34.7	106.9	5.73	4.3	30.5	20.7	0.68	1.98	37.3	15.4	3.0
100	4.0	0.6	1.3	Operation not recommended						Operation not recommended						
	6.0	1.6	3.6	Operation not recommended						27.5	19.7	0.72	2.37	35.6	11.6	3.9
	8.0	3.4	7.8	Operation not recommended						28.0	19.9	0.71	2.30	35.8	12.2	3.7
110	4.0	0.5	1.2	Operation not recommended						Operation not recommended						
	6.0	1.5	3.5	Operation not recommended						24.9	18.7	0.75	2.68	34.0	9.3	4.9
	8.0	3.3	7.6	Operation not recommended						25.4	19.0	0.75	2.61	34.3	9.7	4.5
120	4.0	0.5	1.1	Operation not recommended						Operation not recommended						
	6.0	1.5	3.3	Operation not recommended						21.1	17.2	0.82	2.88	31.0	7.3	5.7
	8.0	3.3	7.5	Operation not recommended						21.6	17.5	0.81	2.80	31.2	7.7	5.4

11/10/09

YS036 - Performance Data

Single Speed X13 ECM (1150 CFM)

EWT °F	Flow gpm	WPD		HEATING - EAT 70°F						COOLING - EAT 80/67°F						
		PSI	FT	HC kBtuh	Power kW	HE kBtuh	LAT °F	COP	HWC kBtuh	TC kBtuh	SC kBtuh	S/T Ratio	Power kW	HR kBtuh	EER	HWC kBtuh
20	5.0	1.5	3.4	Operation not recommended						Operation not recommended						
	7.0	2.6	6.0	Operation not recommended						Operation not recommended						
	9.0	6.1	14.1	23.4	2.31	15.6	86.9	2.97	2.3							
30	5.0	1.4	3.1	Operation not recommended						Operation not recommended						
	7.0	2.5	5.8	27.4	2.34	19.4	90.1	3.43	2.5	35.9	25.1	0.70	1.51	41.1	23.7	---
	9.0	6.0	13.8	28.2	2.38	20.1	90.7	3.47	2.6	36.4	25.6	0.70	1.42	41.2	25.6	---
40	5.0	1.3	2.9	Operation not recommended						Operation not recommended						
	7.0	2.4	5.5	30.8	2.40	22.6	92.8	3.76	2.9	38.7	27.2	0.70	1.62	44.2	23.9	---
	9.0	5.9	13.6	31.9	2.44	23.6	93.7	3.84	2.9	39.2	27.5	0.70	1.54	44.5	25.5	---
50	5.0	1.1	2.6	33.3	2.41	25.0	94.8	4.05	3.1	40.9	29.1	0.71	1.78	47.0	23.0	1.6
	7.0	2.3	5.2	34.5	2.46	26.1	95.8	4.12	3.2	41.5	29.2	0.70	1.72	47.3	24.1	1.5
	9.0	5.8	13.3	35.7	2.50	27.2	96.7	4.18	3.3	42.0	29.4	0.70	1.66	47.7	25.3	1.5
60	5.0	1.0	2.4	37.7	2.48	29.2	98.3	4.45	3.5	39.2	28.5	0.73	1.97	46.0	19.9	2.0
	7.0	2.2	5.0	39.0	2.52	30.4	99.4	4.54	3.6	39.9	28.7	0.72	1.90	46.4	21.0	1.9
	9.0	5.7	13.1	40.2	2.55	31.5	100.4	4.62	3.6	40.5	28.9	0.71	1.84	46.8	22.1	1.8
70	5.0	0.9	2.1	42.1	2.55	33.4	101.9	4.84	3.9	37.6	27.9	0.74	2.16	44.9	17.4	2.5
	7.0	2.1	4.7	43.5	2.58	34.7	103.0	4.95	4.0	38.3	28.2	0.74	2.09	45.4	18.4	2.4
	9.0	5.5	12.8	44.8	2.60	35.9	104.1	5.05	4.1	39.0	28.5	0.73	2.01	45.9	19.4	2.3
80	5.0	0.8	1.8	46.7	2.62	37.8	105.6	5.23	4.4	36.1	27.1	0.75	2.42	44.3	14.9	3.2
	7.0	1.9	4.5	47.7	2.65	38.7	106.4	5.29	4.5	36.7	27.6	0.75	2.31	44.6	15.9	3.0
	9.0	5.4	12.5	48.8	2.68	39.7	107.3	5.35	4.6	37.4	28.0	0.75	2.24	45.0	16.7	2.9
90	5.0	0.7	1.6	51.2	2.68	42.1	109.3	5.60	4.9	34.5	26.3	0.76	2.66	43.6	13.0	3.9
	7.0	1.8	4.2	52.0	2.72	42.8	109.9	5.61	5.1	35.1	27.0	0.77	2.54	43.8	13.8	3.7
	9.0	5.3	12.3	52.8	2.75	43.5	110.5	5.63	5.2	35.8	27.5	0.77	2.46	44.2	14.6	3.6
100	5.0	0.6	1.3	Operation not recommended						Operation not recommended						
	7.0	1.7	4.0	Operation not recommended						33.3	26.4	0.79	2.86	43.0	11.7	4.6
	9.0	5.2	12.0	Operation not recommended						33.8	26.6	0.79	2.77	43.2	12.2	4.4
110	5.0	0.5	1.1	Operation not recommended						Operation not recommended						
	7.0	1.6	3.7	Operation not recommended						31.2	25.3	0.81	3.16	41.9	9.9	5.7
	9.0	5.1	11.8	Operation not recommended						31.8	25.7	0.81	3.07	42.3	10.4	5.4
120	5.0	0.4	0.8	Operation not recommended						Operation not recommended						
	7.0	1.5	3.5	Operation not recommended						26.5	22.7	0.85	3.53	38.6	7.5	6.8
	9.0	5.0	11.5	Operation not recommended						27.1	23.0	0.85	3.43	38.8	7.9	6.4

11/10/09

YS042 - Performance Data

Single Speed X13 ECM (1400 CFM)

EWT °F	Flow gpm	WPD		HEATING - EAT 70°F						COOLING - EAT 80/67°F						
		PSI	FT	HC kBtuh	Power kW	HE kBtuh	LAT °F	COP	HWC kBtuh	TC kBtuh	SC kBtuh	S/T Ratio	Power kW	HR kBtuh	EER	HWC kBtuh
20	5.0	1.6	3.8	Operation not recommended						Operation not recommended						
	8.0	3.6	8.2	Operation not recommended						Operation not recommended						
	11.0	8.0	18.5	27.0	2.61	18.1	85.9	3.04	3.5							
30	5.0	1.5	3.4	Operation not recommended						Operation not recommended						
	8.0	3.4	7.8	30.0	2.61	21.1	87.8	3.37	3.7	43.6	31.7	0.73	1.71	49.4	25.5	---
	11.0	7.9	18.1	31.0	2.66	21.9	88.5	3.42	3.8	44.2	32.3	0.73	1.61	49.7	27.5	---
40	5.0	1.3	3.0	Operation not recommended						Operation not recommended						
	8.0	3.2	7.5	33.4	2.67	24.2	90.1	3.66	4.0	45.7	32.7	0.72	1.85	52.0	24.7	---
	11.0	7.7	17.8	34.8	2.71	25.5	91.0	3.77	4.1	46.3	33.2	0.72	1.75	52.3	26.5	---
50	5.0	1.2	2.7	35.5	2.72	26.2	91.5	3.83	4.4	47.1	33.4	0.71	2.11	54.3	22.4	2.4
	8.0	3.1	7.1	37.0	2.74	27.7	92.5	3.96	4.5	47.8	33.8	0.71	2.00	54.6	23.9	2.4
	11.0	7.5	17.4	38.5	2.76	29.1	93.5	4.10	4.7	48.4	34.1	0.70	1.89	54.8	25.7	2.3
60	5.0	1.0	2.3	39.9	2.78	30.4	94.4	4.20	5.0	46.0	32.8	0.71	2.36	54.1	19.5	3.0
	8.0	2.9	6.7	41.4	2.80	31.8	95.3	4.33	5.1	47.0	33.1	0.70	2.23	54.6	21.1	2.8
	11.0	7.4	17.0	42.9	2.82	33.2	96.3	4.45	5.3	48.0	33.5	0.70	2.09	55.1	23.0	2.7
70	5.0	0.9	2.0	44.2	2.85	34.5	97.2	4.55	5.6	44.9	32.2	0.72	2.62	53.8	17.2	3.8
	8.0	2.8	6.4	45.7	2.87	35.9	98.2	4.68	5.7	46.3	32.5	0.70	2.46	54.6	18.8	3.6
	11.0	7.2	16.7	47.2	2.89	37.4	99.2	4.79	5.9	47.6	32.8	0.69	2.30	55.4	20.7	3.4
80	5.0	0.7	1.6	49.4	2.91	39.5	100.7	4.97	6.3	43.4	31.6	0.73	2.80	53.0	15.5	4.8
	8.0	2.6	6.0	50.6	2.94	40.5	101.5	5.04	6.5	44.4	31.9	0.72	2.67	53.6	16.6	4.5
	11.0	7.1	16.3	51.8	2.97	41.6	102.2	5.11	6.7	45.6	32.1	0.70	2.59	54.4	17.6	4.3
90	5.0	0.5	1.2	54.6	2.98	44.4	104.1	5.37	7.1	42.0	31.0	0.74	3.11	52.6	13.5	6.0
	8.0	2.5	5.7	55.5	3.02	45.2	104.7	5.39	7.3	42.6	31.2	0.73	2.97	52.8	14.3	5.7
	11.0	6.9	16.0	56.3	3.06	45.9	105.2	5.40	7.5	43.5	31.4	0.72	2.88	53.3	15.1	5.5
100	5.0	0.4	0.9	Operation not recommended						Operation not recommended						
	8.0	2.3	5.3	Operation not recommended						39.8	30.2	0.76	3.34	51.2	11.9	7.1
	11.0	6.8	15.6	Operation not recommended						40.5	30.5	0.75	3.24	51.5	12.5	6.8
110	5.0	0.4	0.9	Operation not recommended						Operation not recommended						
	8.0	2.1	4.9	Operation not recommended						36.7	29.1	0.79	3.70	49.3	9.9	8.6
	11.0	6.6	15.2	Operation not recommended						37.4	29.5	0.79	3.60	49.7	10.4	8.3
120	5.0	0.4	0.9	Operation not recommended						Operation not recommended						
	8.0	2.0	4.6	Operation not recommended						33.2	28.2	0.85	4.34	48.0	7.6	10.4
	11.0	6.5	14.9	Operation not recommended						33.9	28.6	0.84	4.22	48.3	8.0	10.0

11/10/09

YS048 - Performance Data

Single Speed X13 ECM (1600 CFM)

EWT °F	Flow gpm	WPD		HEATING - EAT 70°F						COOLING - EAT 80/67°F						
		PSI	FT	HC kBtuh	Power kW	HE kBtuh	LAT °F	COP	HWC kBtuh	TC kBtuh	SC kBtuh	S/T Ratio	Power kW	HR kBtuh	EER	HWC kBtuh
20	6.0	2.2	5.1	Operation not recommended						Operation not recommended						
	9.0	4.4	10.0	Operation not recommended						Operation not recommended						
	12.0	6.8	15.8	30.8	3.09	20.2	87.0	2.92	4.6							
30	6.0	2.0	4.7	Operation not recommended						Operation not recommended						
	9.0	4.2	9.6	35.3	3.12	24.6	89.8	3.31	4.9	50.3	31.3	0.62	2.09	57.4	24.1	---
	12.0	6.7	15.5	35.8	3.15	25.1	90.1	3.33	5.0	51.0	31.9	0.63	1.96	57.7	26.0	---
40	6.0	1.9	4.3	Operation not recommended						Operation not recommended						
	9.0	4.0	9.2	40.1	3.25	29.0	92.8	3.62	5.4	53.1	34.8	0.65	2.29	60.9	23.2	---
	12.0	6.5	15.0	41.9	3.29	30.7	93.9	3.74	5.5	54.0	35.5	0.66	2.16	61.4	25.0	---
50	6.0	1.7	3.9	42.9	3.32	31.6	94.5	3.79	5.9	54.9	37.4	0.68	2.61	63.8	21.0	2.9
	9.0	3.8	8.8	45.5	3.38	34.0	96.1	3.95	6.1	56.0	38.3	0.68	2.49	64.4	22.5	2.8
	12.0	6.3	14.6	48.1	3.43	36.4	97.7	4.11	6.2	57.0	39.1	0.69	2.36	65.1	24.1	2.7
60	6.0	1.5	3.5	49.5	3.47	37.7	98.6	4.18	6.7	54.5	37.4	0.69	2.91	64.4	18.7	3.5
	9.0	3.6	8.4	52.2	3.52	40.2	100.2	4.35	6.8	55.4	38.0	0.69	2.76	64.8	20.0	3.4
	12.0	6.1	14.1	54.9	3.56	42.8	101.9	4.52	7.0	56.2	38.6	0.69	2.62	65.1	21.5	3.2
70	6.0	1.3	3.0	56.1	3.62	43.7	102.6	4.54	7.5	54.1	37.3	0.69	3.20	65.0	16.9	4.5
	9.0	3.5	8.0	58.9	3.65	46.5	104.4	4.73	7.7	54.8	37.7	0.69	3.04	65.1	18.0	4.3
	12.0	5.9	13.7	61.7	3.68	49.2	106.1	4.91	7.9	55.4	38.2	0.69	2.87	65.2	19.3	4.0
80	6.0	1.1	2.6	61.3	3.70	48.7	105.8	4.86	8.4	51.4	35.8	0.70	3.48	63.2	14.8	5.6
	9.0	3.3	7.6	63.2	3.74	50.5	107.0	4.96	8.6	52.1	36.4	0.70	3.31	63.4	15.7	5.3
	12.0	5.8	13.3	65.2	3.78	52.3	108.2	5.05	8.9	52.9	36.9	0.70	3.21	63.9	16.5	5.1
90	6.0	1.0	2.2	66.5	3.78	53.6	109.1	5.16	9.4	48.7	34.3	0.70	3.84	61.8	12.7	7.0
	9.0	3.1	7.1	67.5	3.83	54.5	109.7	5.17	9.7	49.4	35.0	0.71	3.66	61.9	13.5	6.7
	12.0	5.6	12.9	68.6	3.87	55.4	110.3	5.19	10.1	50.4	35.6	0.70	3.54	62.5	14.2	6.4
100	6.0	0.8	1.8	Operation not recommended						Operation not recommended						
	9.0	2.9	6.7	Operation not recommended						46.7	34.3	0.74	4.14	60.8	11.3	8.4
	12.0	5.4	12.5	Operation not recommended						47.4	34.6	0.73	4.00	61.0	11.8	8.0
110	6.0	0.6	1.4	Operation not recommended						Operation not recommended						
	9.0	2.7	6.3	Operation not recommended						43.4	33.2	0.76	4.59	59.1	9.5	10.3
	12.0	5.2	12.1	Operation not recommended						44.3	33.7	0.76	4.46	59.5	9.9	9.7
120	6.0	0.4	1.0	Operation not recommended						Operation not recommended						
	9.0	2.6	5.9	Operation not recommended						40.1	32.0	0.80	5.16	57.7	7.8	12.4
	12.0	5.0	11.6	Operation not recommended						41.0	32.5	0.79	5.01	58.1	8.2	11.8

4/22/11

YS060 - Performance Data

Single Speed X13 ECM (2000 CFM)

EWT °F	Flow gpm	WPD		HEATING - EAT 70°F						COOLING - EAT 80/67°F						
		PSI	FT	HC kBtuh	Power kW	HE kBtuh	LAT °F	COP	HWC kBtuh	TC kBtuh	SC kBtuh	S/T Ratio	Power kW	HR kBtuh	EER	HWC kBtuh
20	9.0	3.8	8.7	Operation not recommended						Operation not recommended						
	12.0	6.3	14.5	Operation not recommended						Operation not recommended						
	15.0	9.7	22.5	41.9	3.96	28.4	87.4	3.10	5.5	Operation not recommended						
30	9.0	3.6	8.4	Operation not recommended						Operation not recommended						
	12.0	6.1	14.1	43.8	3.89	30.5	88.3	3.30	5.9	72.0	49.1	0.68	2.86	81.8	25.2	---
	15.0	9.6	22.2	46.5	4.01	32.8	89.5	3.39	6.1	73.0	50.0	0.68	2.68	82.2	27.2	---
40	9.0	3.5	8.0	Operation not recommended						Operation not recommended						
	12.0	6.0	13.7	49.7	4.03	35.9	91.0	3.62	6.6	70.8	48.8	0.69	3.01	81.0	23.5	---
	15.0	9.4	21.7	52.2	4.12	38.1	92.2	3.71	6.7	71.8	49.5	0.69	2.87	81.6	25.0	---
50	9.0	3.3	7.6	54.6	4.10	40.6	93.3	3.90	7.1	68.5	48.0	0.70	3.24	79.6	21.1	3.9
	12.0	5.8	13.4	56.2	4.16	42.0	94.0	3.96	7.3	69.5	48.5	0.70	3.15	80.3	22.0	3.7
	15.0	9.2	21.3	57.8	4.22	43.4	94.8	4.01	7.5	70.5	48.9	0.69	3.06	81.0	23.0	3.5
60	9.0	3.1	7.3	62.2	4.25	47.7	96.8	4.28	8.0	67.3	47.0	0.70	3.54	79.3	19.0	4.8
	12.0	5.6	13.0	64.3	4.31	49.6	97.8	4.37	8.3	68.2	47.6	0.70	3.44	79.9	19.8	4.6
	15.0	9.1	21.0	66.4	4.36	51.5	98.8	4.46	8.5	69.1	48.3	0.70	3.35	80.5	20.6	4.4
70	9.0	3.0	6.9	69.8	4.40	54.8	100.3	4.64	9.0	66.0	46.0	0.70	3.83	79.1	17.2	6.0
	12.0	5.5	12.6	72.4	4.45	57.2	101.5	4.76	9.3	66.9	46.8	0.70	3.73	79.6	17.9	5.7
	15.0	8.9	20.6	75.0	4.50	59.6	102.7	4.88	9.5	67.7	47.6	0.70	3.63	80.1	18.6	5.4
80	9.0	2.8	6.5	76.2	4.50	60.9	103.3	4.97	10.2	62.2	45.0	0.72	4.35	77.0	14.3	7.6
	12.0	5.3	12.3	78.2	4.55	62.7	104.2	5.04	10.5	63.1	45.7	0.72	4.15	77.2	15.2	7.2
	15.0	8.8	20.2	80.1	4.60	64.4	105.1	5.10	10.7	64.1	46.3	0.72	4.01	77.8	16.0	6.8
90	9.0	2.7	6.1	82.7	4.59	67.1	106.3	5.29	11.4	58.4	43.9	0.75	4.76	74.7	12.3	9.5
	12.0	5.2	11.9	84.0	4.65	68.1	106.9	5.30	11.8	59.3	44.6	0.75	4.54	74.8	13.1	9.0
	15.0	8.6	19.9	85.3	4.70	69.2	107.5	5.31	12.2	60.5	45.0	0.74	4.39	75.5	13.8	8.6
100	9.0	2.5	5.8	Operation not recommended						Operation not recommended						
	12.0	5.0	11.5	Operation not recommended						56.1	43.4	0.77	5.05	73.4	11.1	11.2
	15.0	8.4	19.5	Operation not recommended						57.0	43.7	0.77	4.89	73.7	11.7	10.6
110	9.0	2.3	5.4	Operation not recommended						Operation not recommended						
	12.0	4.8	11.2	Operation not recommended						52.3	41.8	0.80	5.53	71.2	9.5	13.8
	15.0	8.3	19.1	Operation not recommended						53.4	42.4	0.79	5.38	71.8	9.9	13.1
120	9.0	2.2	5.0	Operation not recommended						Operation not recommended						
	12.0	4.7	10.8	Operation not recommended						48.0	39.9	0.83	6.15	69.0	7.8	16.6
	15.0	8.1	18.8	Operation not recommended						49.0	40.5	0.83	5.97	69.4	8.2	15.9

YS070 - Performance Data

Single Speed X13 ECM (2200 CFM)

EWT °F	Flow gpm	WPD		HEATING - EAT 70°F						COOLING - EAT 80/67°F						
		PSI	FT	HC kBTuh	Power kW	HE kBTuh	LAT °F	COP	HWC kBTuh	TC kBTuh	SC kBTuh	S/T Ratio	Power kW	HR kBTuh	EER	HWC kBTuh
20	12.0	4.3	9.8	Operation not recommended						Operation not recommended						
	15.0	5.6	13.0	Operation not recommended						Operation not recommended						
	18.0	9.0	20.8	46.0	4.88	29.3	87.4	2.76	6.5							
30	12.0	4.1	9.4	Operation not recommended						Operation not recommended						
	15.0	5.9	13.6	52.0	4.82	35.5	89.9	3.16	7.0	73.0	46.1	0.63	3.18	83.9	22.9	---
	18.0	8.8	20.3	53.7	4.96	36.8	90.6	3.17	7.3	74.0	47.0	0.64	2.99	84.2	24.7	---
40	12.0	3.8	8.8	Operation not recommended						Operation not recommended						
	15.0	5.2	12.0	58.4	5.00	41.3	92.6	3.42	7.8	74.6	49.3	0.66	3.38	86.1	22.1	---
	18.0	8.6	19.8	60.9	5.10	43.5	93.6	3.50	8.0	76.1	50.5	0.66	3.25	87.2	23.4	---
50	12.0	3.6	8.4	62.8	5.15	45.2	94.4	3.57	8.5	74.2	51.0	0.69	3.64	86.6	20.4	4.3
	15.0	5.0	11.5	65.4	5.19	47.7	95.5	3.69	8.7	76.2	52.5	0.69	3.58	88.4	21.3	4.1
	18.0	8.4	19.3	68.0	5.23	50.2	96.6	3.81	8.9	78.2	54.0	0.69	3.51	90.2	22.3	3.9
60	12.0	3.4	7.9	71.9	5.36	53.6	98.3	3.94	9.5	71.6	50.0	0.70	3.98	85.2	18.0	5.2
	15.0	4.8	11.0	73.9	5.39	55.6	99.1	4.02	9.8	73.3	51.3	0.70	3.90	86.6	18.8	4.9
	18.0	8.2	18.8	76.0	5.42	57.5	100.0	4.11	10.1	75.1	52.5	0.70	3.82	88.1	19.7	4.8
70	12.0	3.2	7.4	81.0	5.56	62.0	102.1	4.27	10.7	69.0	49.0	0.71	4.31	83.7	16.0	6.6
	15.0	4.6	10.5	82.5	5.59	63.4	102.7	4.33	11.0	70.5	50.0	0.71	4.22	84.9	16.7	6.3
	18.0	7.9	18.3	84.0	5.61	64.8	103.3	4.39	11.3	71.9	51.0	0.71	4.13	86.0	17.4	6.0
80	12.0	3.0	6.9	89.7	5.72	70.2	105.8	4.59	12.1	65.3	47.4	0.73	4.93	82.1	13.2	8.3
	15.0	4.4	10.0	91.2	5.78	71.5	106.4	4.63	12.4	66.5	48.3	0.73	4.71	82.6	14.1	7.9
	18.0	7.7	17.9	92.7	5.83	72.9	107.0	4.67	12.8	67.9	49.0	0.72	4.56	83.4	14.9	7.5
90	12.0	2.8	6.4	98.4	5.89	78.3	109.4	4.90	13.6	61.6	45.8	0.74	5.39	80.0	11.4	10.4
	15.0	4.1	9.5	99.9	5.97	79.6	110.1	4.91	14.0	62.5	46.6	0.75	5.15	80.1	12.2	9.9
	18.0	7.5	17.3	101.5	6.04	80.9	110.7	4.92	14.4	63.8	47.0	0.74	4.98	80.8	12.8	9.4
100	12.0	2.5	5.9	Operation not recommended						Operation not recommended						
	15.0	3.9	9.1	Operation not recommended						59.7	44.9	0.75	5.73	79.2	10.4	12.4
	18.0	7.3	16.9	Operation not recommended						60.6	45.3	0.75	5.55	79.5	10.9	11.7
110	12.0	2.3	5.4	Operation not recommended						Operation not recommended						
	15.0	3.7	8.5	Operation not recommended						56.2	42.9	0.76	6.28	77.6	8.9	15.1
	18.0	7.1	16.4	Operation not recommended						57.4	43.5	0.76	6.11	78.2	9.4	14.3
120	12.0	2.1	4.9	Operation not recommended						Operation not recommended						
	15.0	3.5	8.1	Operation not recommended						51.9	41.4	0.80	6.98	75.7	7.4	18.2
	18.0	6.9	15.9	Operation not recommended						53.0	42.0	0.79	6.78	76.1	7.8	17.3

4/22/11

Wiring Schematics

208-230/60/1 PSC

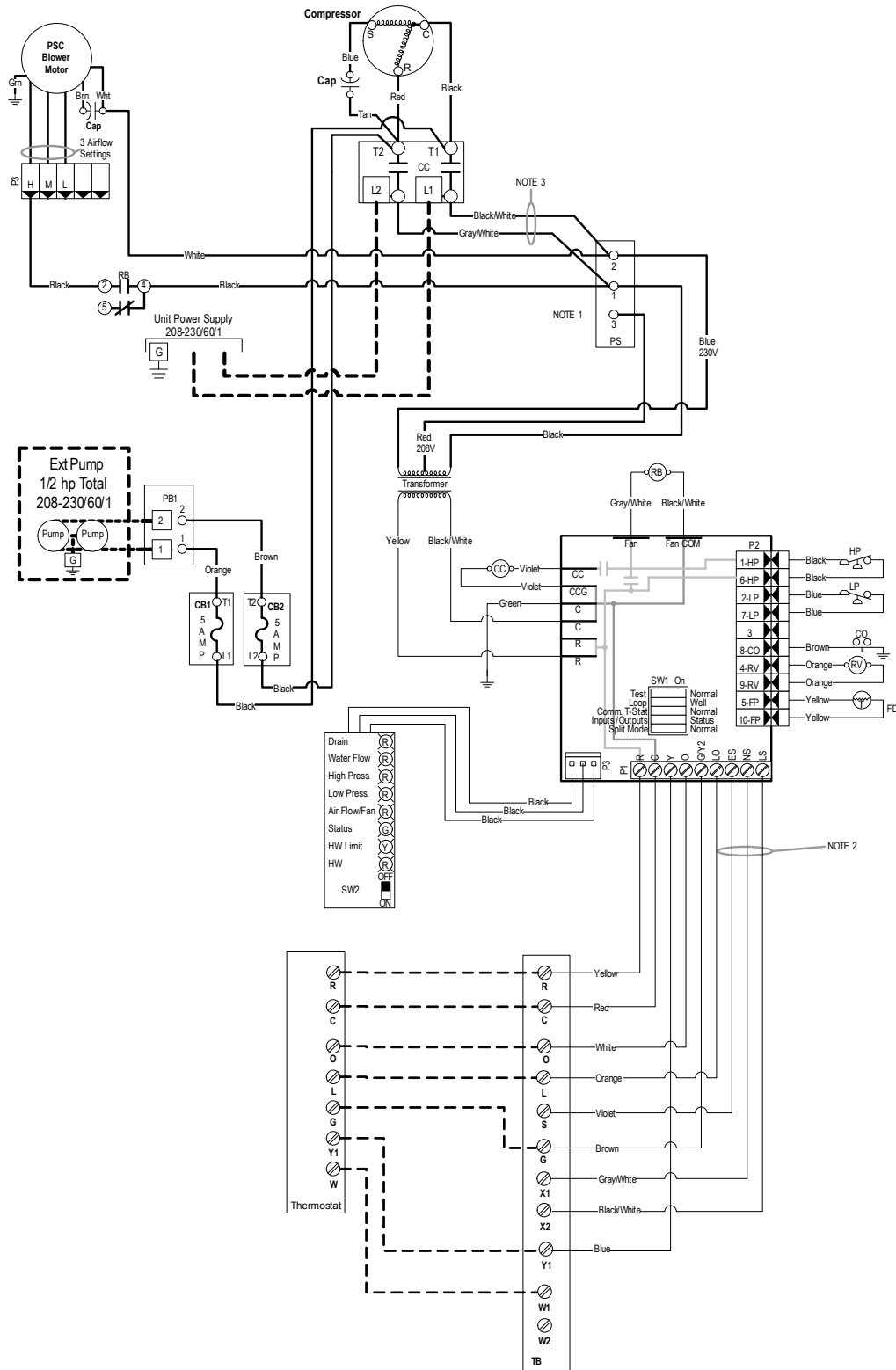

Wiring Schematics cont.

208-230/60/1 PSC cont.

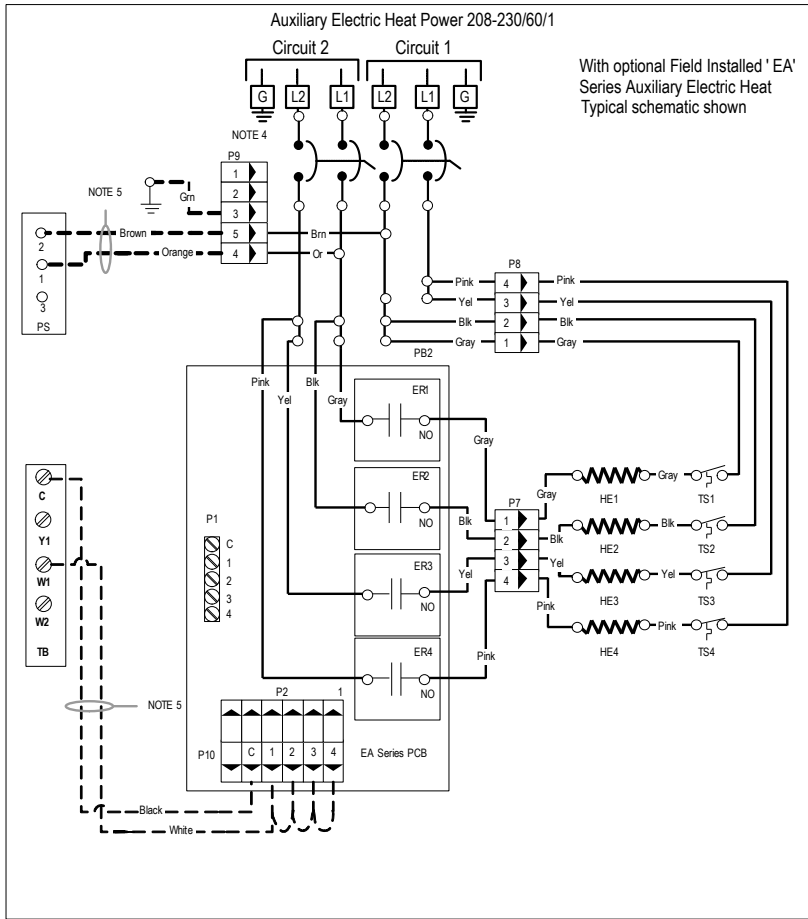

Event	Normal Mode	Test Mode
Power On Delay	5 minutes	15 seconds
Compressor On Delay	10 seconds	2 seconds
Compressor Minimum On Time	2 minutes	5 seconds
Compressor Short Cycle Delay	5 minutes	15 seconds
Blower Off Delay	30 seconds	5 seconds
Fault Recognition Delay - High Pressure	Less than 1 second	Less than 1 second
Start-Up Bypass - Low Pressure	2 minutes	0 seconds
Fault Recognition Delay - Low Pressure	30 seconds	30 seconds
Start-Up Bypass - Freeze Detection Limit	2 minutes	0 seconds
Fault Recognition Delay - Freeze Detection Limit	30 seconds	30 seconds
Fault Recognition Delay - Condensate Overflow	30 seconds	30 seconds

DIP Switch Number	Description	"OFF" Position	"ON" Position
SW1-1	Service Test Mode On the control, allows field selection of "NORMAL" or "TEST" operational modes. Test mode accelerates most timing functions. 16 times to allow faster troubleshooting. Test mode also allows viewing the "CURRENT" status of the fault inputs on the LED display.	Test Mode	Normal Speed Operation
SW1-2	Freeze Detection Setting This DIP switch allows field selection of low source water thermostat fault sensing for "WELL" water(30°F) or "LOOP" (15°F) for antifreeze protected earth loops.	"LOOP" (15°F)	"WELL" (30°F)
SW1-3	Not Available	N/A	Normal Operation
SW1-4	I/O Display Mode This DIP switch enables Input/Output Display or Status/Current Fault on LED Board. Refer to SW2 for operation and positioning.	Input/Output Display Mode	Status/Current Fault Display Mode
SW1-5	Not Available	N/A	Normal Operation
SW2	LED Display (On LED Board) This DIP switch enables Normal Status or Input display mode in the "OFF" position and Current Fault or Output display mode in the "ON" position.	Status or Inputs Display Mode	Current Fault or Output Display Mode

LED	SW1-4 On, SW2 Off	SW1-4 Off, SW2 On	SW1-4 Off, SW2 On
Drain	Drain Pan Overflow Lockout	Y	Compressor
Water Flow	Freeze Detection Lockout (Loop <= 15°F, Well <= 30°F)	G	Fan
High Press	High Pressure Lockout	O	Reversing Valve
Low Press	Low Pressure Lockout	ES	ES
Air Flow	Not Used	NS	NS
Status	Not Used	LS	LS
HW Limit	Not Used	Not Used	Not Used
HW	SW2 Status (Off-Down Position, On-Up Position)	SW2 = Off	SW2 = On

* Flashing Status Light Indicates the Board is Functioning Properly A Solid "On" Indicates a Board Malfunction.

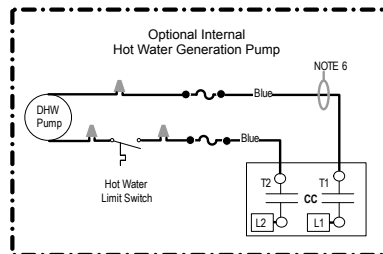

Mode	Inputs	Fan	Comp	RV
Htg	Y	Auto	ON	OFF
Clg	Y, O	Auto	ON	ON
Fan Only	G/Y2	ON	OFF	OFF

Model	Vertical	Horizontal
024	Med	Med
030	Med	Med
036	High	High
042	Med	Med
048	High	High
060	Med	Med
070	High	High

Notes :

- 1 - Swap blue and red leads for 208V operation
- 2 - Requires common connection or 24 VAC for activation
- 3 - Wires are removed when Auxiliary Heat is installed.
- 4 - Field supplied Square D part number QOU141100JBAF (jumper bar assembly) should be used for single source power.
- 5 - Wires are provided with the unit but not connected.
- 6 - Wire not connected at factory, connect to T1 for HW pump operation.

Legend

<ul style="list-style-type: none"> Factory Low Voltage Wiring Factory Line Voltage Wiring Field Low Voltage Wiring Field Line Voltage Wiring Optional Block DC Voltage PCB Traces Field Zone Sensor Wiring Internal Junction Quick Connect Terminal Field Wiring Lug Ground Relay Contacts- N.O., N.C. 	<ul style="list-style-type: none"> Thermistor Relay Coil Switch - Condensate Overflow Switch - High pressure Switch - Low pressure Polarized connector Capacitor Circuit Breaker Jumper Wire
--	--

CB - Circuit Breaker
 CC - Compressor Contactor
 CO - Condensate Overflow Sensor
 ES - Emergency Shutdown
 HP - High Pressure Switch
 LP - Low Pressure Switch
 FD - Freeze Detection Sensor
 RB - Blower Relay
 RV - Reversing Valve Coil

Wiring Schematics cont.

208-230/60/1 X13 ECM

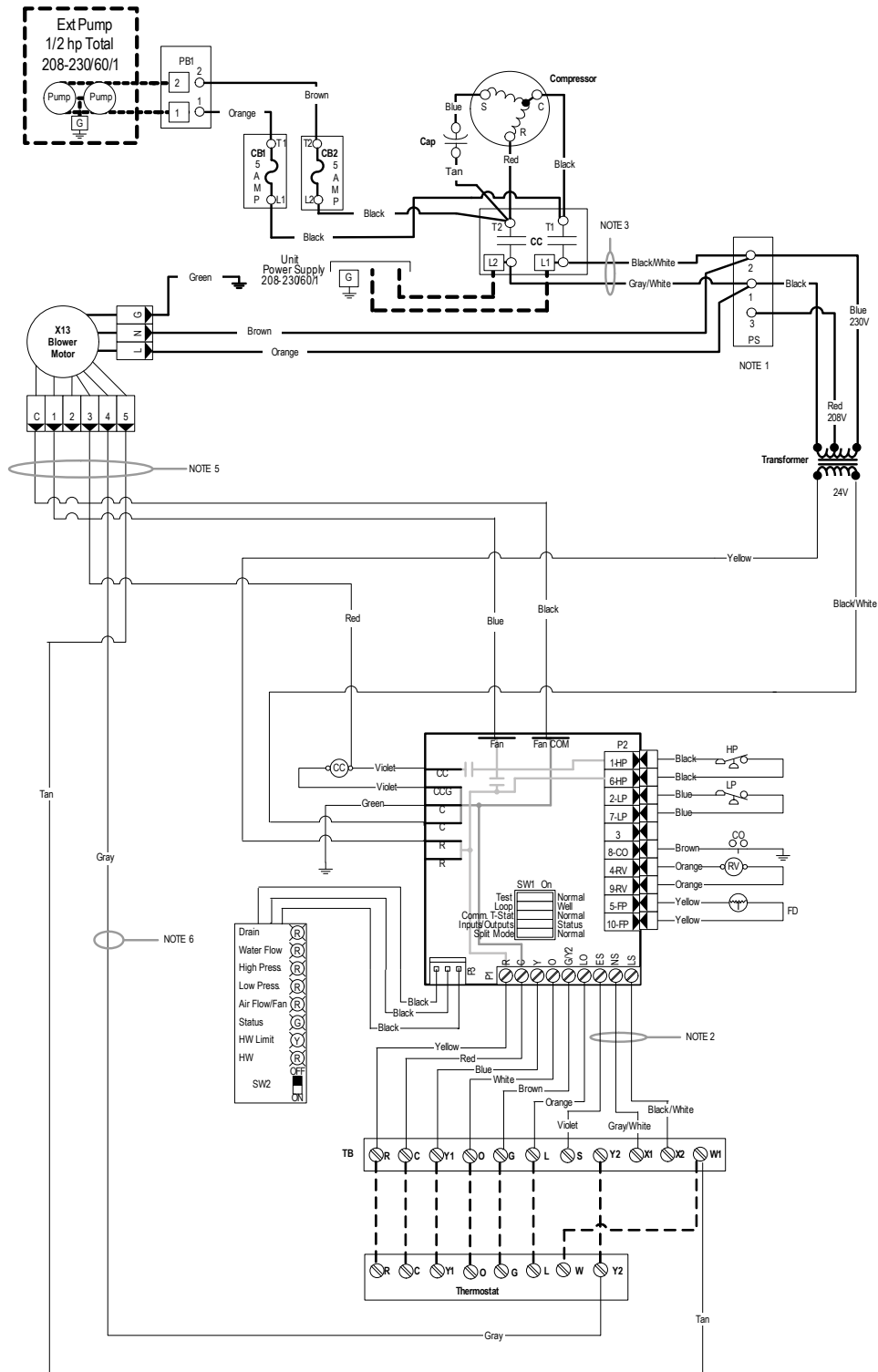

Wiring Schematics cont.

208-230/60/1 X13 ECM cont.

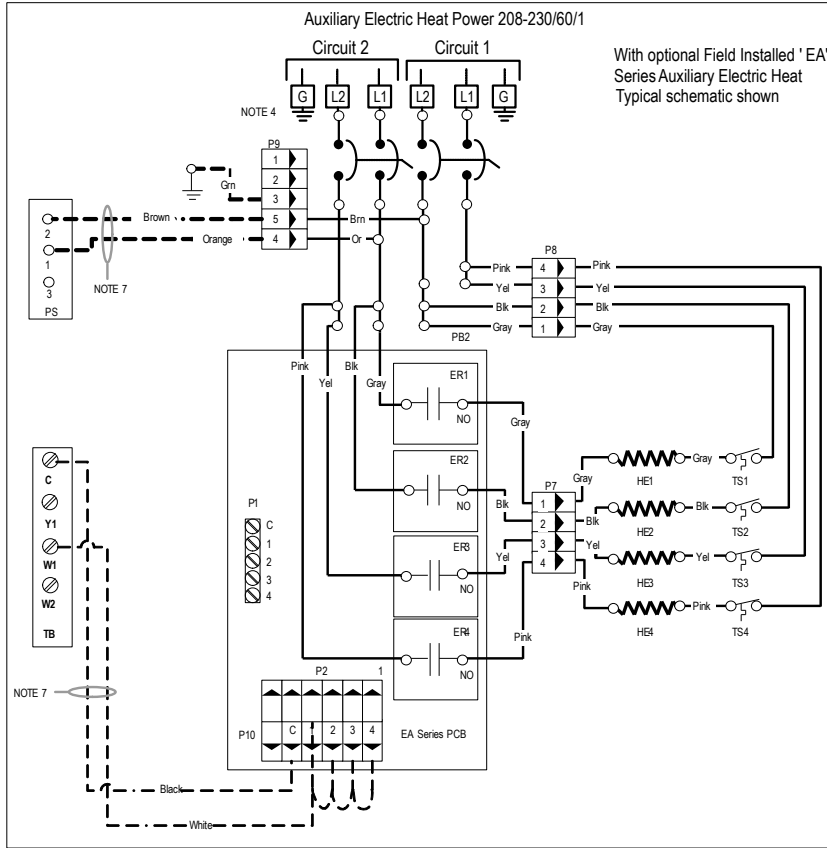

X13 MOTOR LOW VOLTAGE CONNECTIONS					
Model	TAP-1	TAP-2	TAP-3	TAP-4	TAP-5
024	BLUE	Med. Low	Medium	Med. Hi	High
030	BLUE			RED	TAN
036	BLUE			RED	TAN
042	BLUE		RED		TAN
048	BLUE		RED		TAN
060	BLUE		RED		TAN
070	BLUE		RED		TAN

WIRE COLOR	CALL	DESCRIPTION
BLUE	G	FAN
RED	Y1	1ST STAGE H/C
GRAY	Y2	2ND STAGE H/C
TAN	W	AUXILIARY HEAT

Factory Setup DIP Switches(SW1)				
DIP Switch Number	Description	"OFF" Position	"ON" Position	
SW1-1	Service Test Mode On the control allows field selection of "NORMAL" or "TEST" operational modes. Test mode accelerates most timing functions 16 times to allow faster troubleshooting. Test mode also allows viewing the "CURRENT" status of the fault inputs on the LED display.	Test Mode	Normal Speed Operation	
SW1-2	Freeze Detection Setting This DIP switch allows field selection of low source water thermostat fault sensing for "WELL" water (30°F) or "LOOP" (15°F) for antifreeze protected earth loops	"LOOP" (15°F)	"WELL" (30°F)	
SW1-3	Not Available	N/A	Normal Operation	
SW1-4	I/O Display Mode This DIP switch enables Input/Output Display or Status/Current Fault on LED Board. Refer to SW2 for operation and positioning	Input/Output Display Mode	Status/Current Fault Display Mode	
SW1-5	Not Available	N/A	Normal Operation	
SW2	LED Display (On LED Board) This DIP switch enables Normal Status or Input display mode in the "OFF" position and Current Fault or Output display mode in the "ON" position.	Status or Input Display Mode	Current Fault or Output Display Mode	

Operational Logic Table				
Mode	Inputs	Fan	Comp	RV
Htg	Y	Auto	ON	OFF
Clg	Y, O	Auto	ON	ON
Fan Only	G/Y2	ON	OFF	OFF

- Notes:**
- 1 - Swap blue and red leads for 208V operation
 - 2 - Requires common connection or 24 VAC for activation
 - 3 - Wires are removed when Auxiliary Heat is installed.
 - 4 - Field supplied Square D part number QJG141100JBAF (jumper bar assembly) should be used for single source power.
 - 5 - Refer to the X13 Motor Low Voltage Connection Table.
 - 6 - Wire is provided with the unit but not connected to the X13 motor.
 - 7 - Wires are provided with the unit but not connected.
 - 8 - Wire not connected at factory, connect to T1 for HW pump operation.

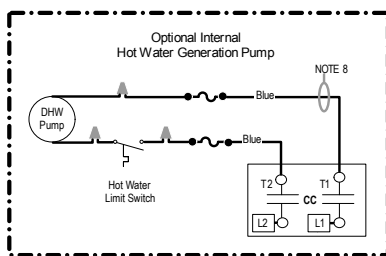

Normal Mode Control Timing Table		
Event	Normal Mode	Test Mode
Power On Delay	5 minutes	15 seconds
Compressor On Delay	10 seconds	2 seconds
Compressor Minimum On Time	2 minutes	5 seconds
Compressor Short Cycle Delay	5 minutes	15 seconds
Blower Off Delay	30 seconds	5 seconds
Fault Recognition Delay - High Pressure	Less than 1 second	Less than 1 second
Start-Up Bypass - Low Pressure	2 minutes	0 seconds
Fault Recognition Delay - Low Pressure	30 seconds	30 seconds
Start-Up Bypass - Low Water Coil Limit	2 minutes	0 seconds
Fault Recognition Delay - Low Water Coil Limit	30 seconds	30 seconds
Fault Recognition Delay - Condensate Overflow	30 seconds	30 seconds

X13 MOTOR BLOWER TABLE						
MODEL	ESP	TAP-1 Low (cfm)	TAP-2 Med. Low (cfm)	TAP-3 Medium (cfm)	TAP-4 Med. Hi (cfm)	TAP-5 High (cfm)
024	0.3	480	670	740	800	890
030	0.3	680	870	920	1040	1140
036	0.3	720	1020	1070	1150	1190
042	0.5	1100	1310	1410	1520	1640
048	0.5	1190	1450	1580	1690	1870
060	0.5	1540	1750	1880	2010	2210
070	0.5	1560	1790	1900	2030	2230

LED Display Mode Table			
Status Display Mode			
LED	SW1-4 On, SW2 Off		
Drain	Drain Pan Overflow Lockout		
Water Flow	Freeze Detection (Loop <= 15°F, Well <= 30°F)		
High Press	High Pressure Lockout		
Low Press	Low Pressure Lockout		
Air Flow	Not Used		
Status	Microprocessor Malfunction*		
HW Limit	Not Used		
HW	SW2 Status/Off-Down Position, One Up Position		

Diagnostic Display Modes			
	Current Fault Display Mode	Inputs Display Mode	Outputs Display Mode
LED	SW1-4 On, SW2 On	SW1-4 Off, SW2 Off	SW1-4 Off, SW2 On
Drain	Drain Pan Overflow Lockout	Y	Compressor
Water Flow	Low Water Coil Limit Lockout	G	Fan
High Press	High Pressure Lockout	O	Reversing Valve
Low Press	Low Pressure Lockout	ES	ES
Air Flow	Not Used	NS	NS
Status	Not Used	LS	LS
HW Limit	Not Used	Not Used	Not Used
HW	SW2 = On	SW2 = Off	SW2 = On

*Flashing Status Light Indicates the Board is Functioning Properly A Solid "On" Indicates a Board Malfunction

Legend

- Factory Low Voltage Wiring
- Factory Line Voltage Wiring
- Field Low Voltage Wiring
- Field Line Voltage Wiring
- Optional Block
- DC Voltage PCB Traces
- Field Zone Sensor Wiring
- Internal Junction
- Quick Connect Terminal
- Field Wiring Lug
- Ground
- Relay Contacts - NO...NC
- Thermistor
- Relay Coil
- Switch-Condensate Overflow
- Switch-High pressure
- Switch-Low pressure
- Polarized connector
- Capacitor
- Circuit Breaker
- Jumper Wire
- ES - Emergency Shutdown
- HP - High Pressure Switch
- LP - Low Pressure Switch
- FD - Freeze Detection Sensor
- RB - Blower Relay
- RV - Reversing Valve Coil
- NS - Night Setback
- LS - Loadshed

Engineering Guide Specifications

General

Furnish and install water source heat pumps as indicated on the plans. Equipment shall be completely assembled, piped and internally wired. Capacities and characteristics as listed in the schedule and the specifications that follow. The reverse cycle heating/cooling units shall be either suspended type with horizontal air inlet and discharge or floor mounted type with horizontal air inlet and vertical upflow air discharge. Units shall be AHRI/ISO 13256-1 certified and listed by a nationally recognized safety-testing laboratory or agency, such as ETL Testing Laboratory. Each unit shall be computer run-tested at the factory with conditioned water and operation verified to catalog data. Each unit shall be mounted on a pallet and shipped in a corrugated box or stretch-wrapped. The units shall be designed to operate with entering liquid temperature between 20°F and 120°F [-6.7°C and 48.9°C].

Casing and Cabinet

The cabinet shall be fabricated from heavy-gauge galvanized steel and finished with corrosion-resistant powder coating. This corrosion protection system shall meet the stringent 1000 hour salt spray test per ASTM B117. The interior shall be insulated with 1/2 in. thick, multi-density, cleanable aluminum foil coated glass fiber with edges sealed or tucked under flanges to prevent the introduction of glass fibers into the discharge air. Standard cabinet panel insulation must meet NFPA 90A requirements, air erosion and mold growth limits of UL-181, stringent fungal resistance test per ASTM-C1071 and ASTM G21, and shall meet zero level bacteria growth per ASTM G22. Unit insulation must meet these stringent requirements or unit(s) will not be accepted.

One (horizontal) to two (vertical) blower and three compressor compartment access panels shall be 'lift-out' removable with supply and return ductwork in place.

A duct collar shall be provided on the supply air opening. Standard size 1 in. [2.54 cm] MERV 8 filters shall be provided with each unit. Units shall have a return air filter rack that is field convertible from 1 in. [2.54 cm] to 2 in. [5.1 cm]. The vertical units shall have a removable insulated divider panel between the air handling section and the compressor section to minimize the transmission of compressor noise and to permit operational service testing without air bypass. Vertical units shall be supplied with left or right horizontal air inlet and top vertical air discharge. Horizontal units shall be supplied with left or right air inlet and side or end air discharge.

Refrigerant Circuit

All units shall utilize the non-ozone depleting and low global warming potential refrigerant R410A. All units shall contain a sealed refrigerant circuit including a hermetic motor-compressor, bidirectional thermostatic expansion valve, finned tube air-to-refrigerant heat exchanger, reversing valve, coaxial tube water-to-refrigerant heat exchanger, optional hot water generator coil, and service ports.

Compressors shall be high-efficiency single speed scroll type designed for heat pump duty and mounted on vibration isolators. The compressor shall be double isolation mounted using selected durometer grommets to provide vibration free compressor mounting. Compressor motors shall be single-phase PSC with overload protection.

The air coil shall be sized for low-face velocity and constructed of lanced aluminum fins bonded to rifled copper tubes in a staggered pattern not less than three rows deep for enhanced performance. The coil will be electro-coated for maximum protection against formicary corrosion.

The coaxial water-to-refrigerant heat exchanger shall be designed for low water pressure drop, constructed of a convoluted copper (cupronickel option) inner tube and a steel outer tube, and foam insulated to prevent condensation at low liquid temperatures. Refrigerant to air heat exchangers shall utilize enhanced corrugated lanced aluminum fins and rifled copper tube construction rated to withstand 600 PSIG (4135 kPa) refrigerant working pressure. Refrigerant to water heat exchangers shall be of copper inner water tube and steel refrigerant outer tube design, rated to withstand 600 PSIG (4135 kPa) working refrigerant pressure and 450 PSIG (3101 kPa) working water pressure. The thermostatic expansion valve shall provide proper superheat over the entire liquid temperature range with minimal "hunting." The valve shall operate bidirectionally without the use of check valves.

Option: Cupronickel refrigerant to water heat exchanger shall be of copper-nickel inner water tube and steel refrigerant outer tube design, rated to withstand 600 PSIG (4135 kPa) working refrigerant pressure and 450 PSIG (3101 kPa) working water pressure. Heat exchanger shall be foam insulated.

Blower Motor and Assembly

The blower shall be a direct drive centrifugal type with a dynamically balanced wheel. The housing and wheel shall be designed for quiet low outlet velocity operation. The blower housing shall be removable from the unit without disconnecting the supply air ductwork for servicing of the blower motor. The blower motor shall be a 5 speed X13 ECM type. The X13 ECM blower motor shall be soft starting, shall maintain constant torque over its operating static range, and shall provide 5 speed settings. The blower motor shall be isolated from the housing by rubber grommets. The motor shall be permanently lubricated and have thermostatic overload protection. X13 ECM motors shall be long-life ball bearing type.

Option: PSC blower motor shall be a three-speed PSC type.

Option: High static blower motors shall be available on certain PSC models.

Engineering Guide Specifications cont.

Electrical

A control box shall be located within the unit compressor compartment and shall contain a 75VA transformer, 24 volt activated, 2 pole compressor contactor, terminal block for thermostat wiring and solid-state controller for complete unit operation. Electromechanical operation WILL NOT be accepted. Units shall be name-plated for use with time delay fuses or HACR circuit breakers. Unit controls shall be 24 volt and provide heating or cooling as required by the remote thermostat/sensor.

A microprocessor-based controller that interfaces with a multi-stage electronic thermostat to monitor and control unit operation shall be provided. The control shall provide operational sequencing, blower control, high and low pressure switch monitoring, freeze detection, condensate overflow sensing, lockout mode control, LED status and fault indicators, fault memory, and field selectable options. The control shall provide fault retry three times before locking out to limit nuisance trips.

A terminal block with screw terminals will be provided for field control wiring. All units shall have knockouts for entrance of low and line voltage wiring. The blower motor and control box shall be harness plug wired for easy removal.

Optional GeoStart™ (compressor Soft Starter) shall be factory installed for use in applications that require low starting amps, reduced compressor start-up noise, off-grid, and improved start-up behavior. GeoStart shall reduce normal starting current by 60% on 208/60/1 units.

Piping

Supply and return water connections shall be 1 in. [2.54 cm] FPT brass swivel fittings, which provide a union and eliminate the need for pipe wrenches and sealants when making field connections. The optional hot water generator shall have sweat type fittings. All water piping shall be insulated to prevent condensation at low liquid temperatures, on the vertical units, the condensate connection shall be a 3/4 in. [1.91 cm] PVC socket with internally-trapped hose that can be routed to front or side locations.

Hanger Kit

(included with horizontal units only - field installed)

The hanger kit shall consist of galvanized steel brackets, bolts, lock washers, and isolators and shall be designed to fasten to the unit bottom panel for suspension from 3/8 in. threaded rods. Unit sizes 024-036 shall include four (4) brackets and the 042-070 shall include six (6) hanger brackets. Brackets shall not inhibit filter removal in any way.

Accessories

Thermostat (field-installed)

A multi-stage auto-changeover electronic digital thermostat shall be provided. The thermostat shall offer two heating stages and one cooling stage with precise temperature control. An OFF-HEAT-AUTO-COOL-EMERG system switch, OFF-AUTO blower switch, and indicating LEDs shall be provided. The thermostat shall display in °F or °C.

AlpinePure MERV 13 Filter

A 2 in. [51 mm] MERV 13 filter can help fulfill a credit under the LEED Rating System. Its low initial resistance promotes low energy consumption (0.21 in. w.g. @ 300 FPM) and provides nearly twice the life of a standard filter (300 fpm vs. standard 500 fpm application).

Hot Water Generation

An optional heat reclaiming hot water generator coil of vented double-wall copper construction suitable for potable water shall be provided. The coil and hot water circulating pump shall be factory mounted inside the unit with integral electronic high limit temperature monitoring.

Earth Loop Flow Center (field-installed)

A self-contained module shall provide all liquid flow, fill and connection requirements for ground source closed loop systems up to 20 GPM. The pumps shall be wired to a power block located in the nearest unit.

Auxiliary Heater (field-installed)

An electric resistance heater shall provide supplemental and/or emergency heating capability. Vertical units shall have the control and resistance heater coil assembly mounted internally. For horizontal units, the control box shall be mounted internally while the resistance heater coil assembly shall be mounted externally. The heater shall feed line voltage power to the unit blower and transformer to provide emergency heat capability in the event of an open compressor circuit breaker.

AlpinePure HRV/ERV (field installed)

A self-contained unit shall provide removal of stale air while replenishing the structure with an equal amount of fresh, clean air. The incoming and exhaust air streams shall be completely separate through the exchanger. The Heat Recovery Ventilator (HRV) shall transfer sensible heat from the stale exhaust air to the fresh incoming air with a Sensible Efficiency up to 79%. The HRV shall be equipped with a Defrost Mode. The Energy Recovery Ventilator (ERV) shall transfer sensible heat as well as latent heat with a Total Efficiency of 50%. The ERV shall be designed for use in warm humid areas with heavy air conditioning use. The ERV shall not be recommended for use in areas where the temperature drops below 25°F (-4°C) for more than five days. The ERV shall not be equipped with a Defrost Mode.

Engineering Guide Specifications cont.

Electronic Air Cleaner (field-installed)

A 1 in. [25 mm] electronic air cleaner, cleanable 97% efficiency at 0.3 microns and larger, shall be provided in lieu of the standard throwaway filter. The initial pressure drop across the filter shall not exceed 0.2 in. w.g. at 300 fpm force velocity.

Electrostatic Air Cleaner (field-installed)

A 1 in. [25 mm] electrostatic air cleaner, cleanable 90% efficiency, shall be provided in lieu of the standard throwaway filter. The initial pressure drop across the filter shall not exceed 0.15 in. w.g. at 300 fpm force velocity.



Product: **Magnolia Series**
Type: Geothermal Heat Pumps
Size: 2-6 Tons

Document Type: Specification Catalog
Part Number: SC1100AY
Release Date: 07/11