



SPECIFICATION CATALOG

GEOHERMAL HEAT PUMPS



AFFORDABLE RENEWABLE CLEAN



ASTON SERIES INDOOR SPLIT

Table of Contents

General Introduction	4
Model Nomenclature	5
AHRI Data	6-7
Design Features	8
Indoor Split Features	9
Physical Data	9
Dimensional Data	10
Electrical Data	10
Model Nomenclature - Air Handler	11
Air Handler Compatibility	11
Physical Data - Air Handler	12
Line Set Sizes	12
Model Nomenclature - Coil	13
Refrigerant Coil Compatibility	13
Reference Calculations	14
Legend and Notes	14
Operating Limits	14
Pressure Drop	15
Performance Data	16-32
Wiring Schematics	33-34
Microprocessor Control	35-37
Engineering Guide Specifications	38

GSZ/GTZ Series Indoor Split



GSZ/GTZ Series splits are designed for indoor installations, and are connected to an indoor air handler via refrigerant lines and control wiring. G Series units utilize the ozone-safe R-410A refrigerant to meet the most stringent EPA requirements now and for many years to come. Easily accessible controls and connections for refrigerant piping and water piping make this unit simple to install in a wide variety of applications. Heavy gauge metal cabinets are coated with durable polyester powder coat paint for long lasting beauty and protection. The GSZ/GTZ Series split will provide exceptional performance and comfort for many years. And because there is no outdoor blower like ordinary air conditioners or heat pumps, the GSZ/GTZ Series is “whisper quiet”.

GSZ/GTZ Series units are performance-certified to AHRI ISO 13256-1 standards, are ETL safety listed, and are ENERGYSTAR® qualified.

As a leader in the industry, we are dedicated to innovation, quality and customer satisfaction. In fact, every unit built is exposed to a wide range of quality control procedures throughout the assembly process and is then subjected to a rigorous battery of computerized run tests to certify that it meets or exceeds performance standards for efficiency and safety, and will perform flawlessly at startup. As further affirmation of our quality standards, each unit carries our exclusive Quality Assurance emblem, signed by the final test technician.

Model Nomenclature

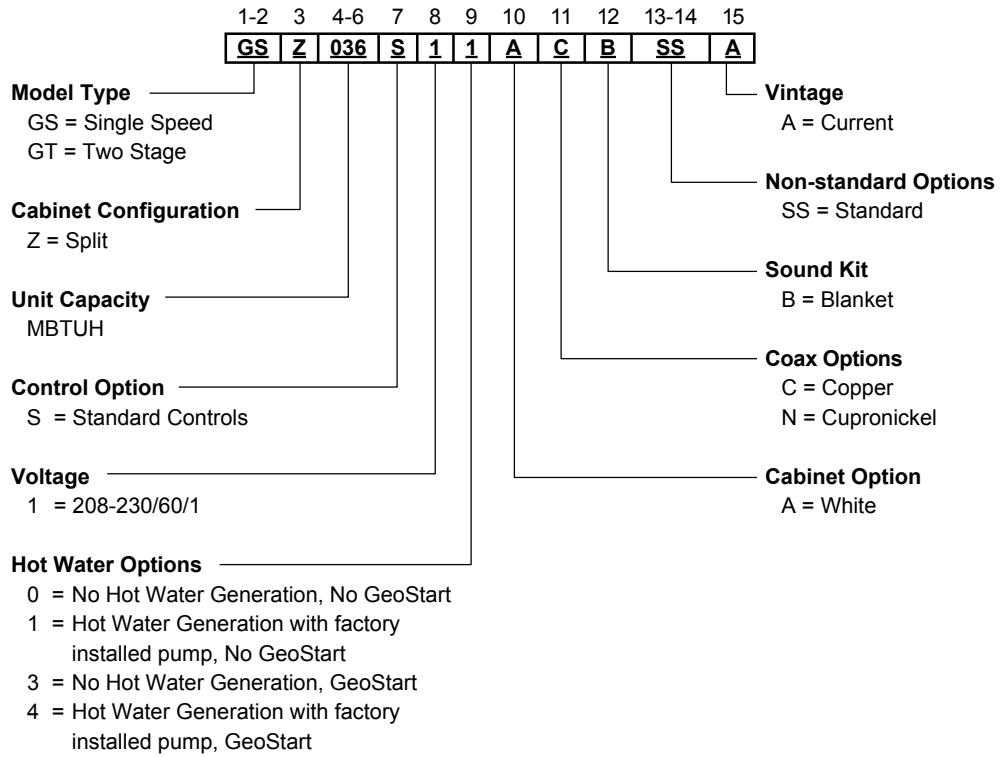

AHRI Data

AHRI/ASHRAE/ISO 13256-1
English (IP) Units

Model	Capacity Modulation	Flow Rate		Water Loop Heat Pump				Ground Water Heat Pump				Ground Loop Heat Pump			
				Cooling Brine EWT 86°F		Heating Brine EWT 68°F		Cooling EWT 59°F		Heating EWT 50°F		Cooling Brine Full Load 77°F Part Load 68°F		Heating Brine Full Load 32°F Part Load 41°F	
		gpm	cfm	Capacity Btuh	EER Btuh/W	Capacity Btuh	COP	Capacity Btuh	EER Btuh/W	Capacity Btuh	COP	Capacity Btuh	EER Btuh/W	Capacity Btuh	COP
026	Full	8	900	25,000	14.6	30,500	5.1	27,800	21.8	25,000	4.6	26,200	17.0	19,500	3.9
	Part	7	700	18,500	16.6	22,000	5.6	21,300	28.4	17,700	4.8	21,000	24.5	16,200	4.4
038	Full	9	1200	34,000	14.6	40,100	5.0	34,300	20.4	33,100	4.5	35,000	17.1	25,700	3.8
	Part	8	800	25,000	16.6	30,000	5.3	25,200	27.0	24,400	4.4	27,000	25.3	22,100	4.2
049	Full	12	1500	45,900	14.0	56,800	4.7	50,500	20.2	46,700	4.4	47,700	16.1	37,000	3.8
	Part	11	1300	35,000	16.2	43,000	5.5	37,300	25.8	33,000	4.7	38,000	22.9	30,500	4.3
064	Full	16	1800	56,300	14.7	67,100	4.6	63,800	19.2	55,800	4.3	59,100	15.5	43,200	3.6
	Part	14	1500	42,900	15.7	49,500	5.1	50,000	24.9	41,000	4.3	47,900	22.2	36,800	3.9
072	Full	18	1800	60,400	13.3	80,600	4.6	67,900	17.8	63,100	3.9	62,700	15.0	50,300	3.4
	Part	16	1600	49,700	14.6	60,200	4.8	57,200	22.8	48,400	4.0	53,800	20.0	42,800	3.8
022	Single	8	800	19,700	16.3	23,500	5.3	23,300	27.9	18,900	4.5	21,800	19.5	14,000	3.7
030	Single	8	1000	25,800	17.3	32,000	5.5	28,500	24.9	25,300	4.9	26,800	19.8	19,700	4.0
036	Single	9	1200	31,400	17.6	37,600	5.5	33,900	27.0	30,000	4.7	31,900	19.8	24,000	4.0
042	Single	10	1400	39,000	17.3	41,400	5.3	42,900	25.3	33,000	4.5	39,900	19.9	25,300	3.7
048	Single	12	1500	44,200	15.5	55,400	5.2	48,900	23.8	45,100	4.5	46,200	18.1	35,300	3.8
060	Single	15	1800	54,600	14.4	66,300	4.6	62,300	21.1	52,900	4.1	57,000	17.0	44,500	3.6
070	Single	18	1800	60,200	13.2	76,000	4.2	68,500	19.2	63,000	3.7	63,200	15.1	50,800	3.3

Cooling capacities based upon 80.6°F DB, 66.2°F WB entering air temperature
 Heating capacities based upon 68°F DB, 59°F WB entering air temperature
 All ratings based upon operation at the lower voltage of dual voltage rated models.
 Refer to the air handler compatibility table for matching air handler.

11/12/10

Energy Star Compliance Table

Model	Tier 1		Tier 2	
	Ground Water	Ground Loop	Ground Water	Ground Loop
026	Yes	Yes	Yes	Yes
038	Yes	Yes	Yes	Yes
049	Yes	Yes	Yes	Yes
064	Yes	Yes	Yes	Yes
072	Yes	Yes	Yes	Yes
022	Yes	Yes	Yes	Yes
030	Yes	Yes	Yes	Yes
036	Yes	Yes	Yes	Yes
042	Yes	Yes	Yes	Yes
048	Yes	Yes	Yes	Yes
060	Yes	Yes	Yes	Yes
070	Yes	No	Yes	No

11/12/10

Energy Star Rating Criteria

In order for water-source heat pumps to be Energy Star rated they must meet or exceed the minimum efficiency requirements listed below. Please note there are 3 Tier levels that dictate minimum efficiency for water source pumps. Only one tier level is active at a given moment.

Tier 1: 12/1/2009 – 12/31/2010

	EER	COP
Closed loop water-to-air	14.1	3.3
Open loop water-to-air	16.2	3.6
Closed loop water-to-water	15.1	3.0
Open loop water-to-water	19.1	3.4

Tier 2: 1/1/2011 – 12/31/2011

	EER	COP
Closed loop water-to-air	16.1	3.5
Open loop water-to-air	18.2	3.8
Closed loop water-to-water	15.1	3.0
Open loop water-to-water	19.1	3.4

Tier 3: 1/1/2012 – No Effective End Date Published

	EER	COP
Closed loop water-to-air	17.1	3.6
Open loop water-to-air	21.1	4.1
Closed loop water-to-water	16.1	3.1
Open loop water-to-water	20.1	3.5



AHRI Data cont.

The performance standard AHRI/ASHRAE/ISO 13256-1 became effective January 1, 2000 and replaces AHRI Standards 320, 325, and 330. This new standard has three major categories: Water Loop (comparable to ARI 320), Ground Water (ARI 325), and Ground Loop (ARI 330). Although these standards are similar there are some differences:

Unit of Measure: The Cooling COP

The cooling efficiency is measured in EER (US version measured in Btuh per Watt. The Metric version is measured in a cooling COP (Watt per Watt) similar to the traditional COP measurement.

Water Conditions Differences

Entering water temperatures have changed to reflect the centigrade temperature scale. For instance the water loop heating test is performed with 68°F (20°C) water rounded down from the old 70°F (21.1°C).

Air Conditions Differences

Entering air temperatures have also changed (rounded down) to reflect the centigrade temperature scale. For instance the cooling tests are performed with 80.6°F (27°C) dry bulb and 66.2°F (19°C) wet bulb entering air instead of the traditional 80°F (26.7°C) DB and 67°F (19.4°C) WB entering air temperatures. 80.6/66.2 data may be converted to 80/67 using the entering air correction table. This represents a significantly lower relative humidity than the old 80/67 of 50% and will result in lower latent capacities.

Pump Power Correction Calculation

Within each model, only one water flow rate is specified for all three groups and pumping Watts are calculated using the following formula. This additional power is added onto the existing power consumption.

- Pump power correction = (gpm x 0.0631) x (Press Drop x 2990) / 300

Where 'gpm' is waterflow in gpm and 'Press Drop' is the pressure drop through the unit heat exchanger at rated water flow in feet of head.

Blower Power Correction Calculation

Blower power is corrected to zero external static pressure using the following equation. The nominal airflow is rated at a specific external static pressure. This effectively reduces the power consumption of the unit and increases cooling capacity but decreases heating capacity. These Watts are significant enough in most cases to increase EER and COPs fairly dramatically over ARI 320, 325, and 330 ratings.

- Blower Power Correction = (cfm x 0.472) x (esp x 249) / 300

Where 'cfm' is airflow in cfm and 'esp' is the external static pressure at rated airflow in inches of water gauge.

ISO Capacity and Efficiency Calculations

The following equations illustrate cooling calculations:

- ISO Cooling Capacity = Cooling Capacity (Btuh) + (Blower Power Correction (Watts) x 3.412)
- ISO EER Efficiency (W/W) = ISO Cooling Capacity (Btuh) x 3.412 / [Power Input (Watts) - Blower Power Correction (Watts) + Pump Power Correction (Watt)]

The following equations illustrate heating calculations:

- ISO Heating Capacity = Heating Capacity (Btuh) - (Blower Power Correction (Watts) x 3.412)
- ISO COP Efficiency (W/W) = ISO Heating Capacity (Btuh) x 3.412 / [Power Input (Watts) - Blower Power Correction (Watts) + Pump Power Correction (Watt)]

Comparison of Test Conditions

	ARI 320	ISO/AHRI 13256-1 WLHP	ARI 325	ISO/AHRI 13256-1 GWHP	ARI 330	ISO/AHRI 13256-1 GLHP
Cooling						
Entering Air - DB/WB °F	80/67	80.6/66.2	80/67	80.6/66.2	80/67	80.6/66.2
Entering Water - °F	85	86	50/70	59	77	77
Fluid Flow Rate	*	**	**	**	**	**
Heating						
Entering Air - DB/WB °F	70	68	70	68	70	68
Entering Water - °F	70	68	50/70	50	32	32
Fluid Flow Rate	*	**	**	**	**	**

Note *: Flow rate is set by 10°F rise in standard cooling test Part load entering water conditions not shown.

Note **: Flow rate is specified by the manufacturer

WLHP = Water Loop Heat Pump; GWHP = Ground Water Heat Pump; GLHP = Ground Loop Heat Pump

Conversions:

Airflow (lps) = CFM x 0.472;

ESP (Pascals) = ESP (in wg) x 249;

Water Flow (lps) = GPM x 0.0631;

Press Drop (Pascals) = Press Drop (ft hd) x 2990

Design Features

Application Flexibility

- Safe, efficient operation in a wide range of liquid temperatures (25°F to 110°F) and flow rates (as low as 1.5 GPM/ton in open loop applications when EWT >50°F).
- Easily accessible loop pump wiring.

Operating Efficiencies

- Environmentally friendly R-410A refrigerant.
- LED fault and status lights with memory for easy diagnostics.
- Accumulator on all models for compressor reliability.
- AHRI 13256-1 rating for heating COPs, cooling EERs and low water flow requirements.
- Optional hot water generator creates hot water at considerable savings while improving overall system efficiency.
- High-stability expansion valve delivers optimum refrigerant flow over a wide range of conditions.
- Efficient Copeland scroll compressors in all units.
- Oversized coaxial tube water-to-refrigerant heat exchanger operates at low liquid pressure drops.
- Optional convoluted copper water tube functions efficiently at low flow rates, and provides freeze-damage resistance.

Service Advantages

- Easily removable top, front and side access panels.
- Easily accessible thermal expansion valve.
- Brass, swivel-type water connections for ease of installation.
- High- and low-pressure service ports in refrigerant circuit.

Factory Quality

- All units are manufactured on an automated testing assembly line. This assembly line features monitoring and assembly processes that lead the industry such as:
 - Component verification through bar codes.
 - Multiple automatic leak and pressure tests.
 - Performance of a water-based run test measuring both functionality and performance of the unit.
 - Database management of all run test parameters for service analysis.
 - Integrated fail safe system that prevents packaging of a failed unit.
- Heavy-gauge steel cabinets are painted with durable polyester powder coat paint for long lasting beauty and service.
- All refrigerant brazing is performed in a nitrogen atmosphere.
- All units are deep evacuated to less than 150 microns prior to refrigerant charging.
- All joints are helium leak-tested to ensure an annual leak rate of less than 1/4 ounce.
- Refrigerant suction lines, hot water generator coil, and all water pipes are fully insulated to reduce condensation problems in low temperature operation.
- Noise reduction features: Double isolation mounted compressors, insulated cabinet using 1/2-inch coated glass fiber.
- Compressor sound blanket.
- Safety features include high- and low-pressure refrigerant controls to protect the compressor.
- Coaxial heat exchanger and optional hot water generator are ThermaShield coated.

Options and Accessories

- Optional ThermaShield coated hot water generator with internally mounted pump and water heater plumbing connector
- Electronic auto-changeover thermostat with 3-stage heat/2-stage cool and indicator LEDs
- Closed loop flow center and loop circulating kits
- Hose kits
- Additional accessory relay
- Mounting pad
- Well water kits
- GeoStart soft starter

Indoor Split Features

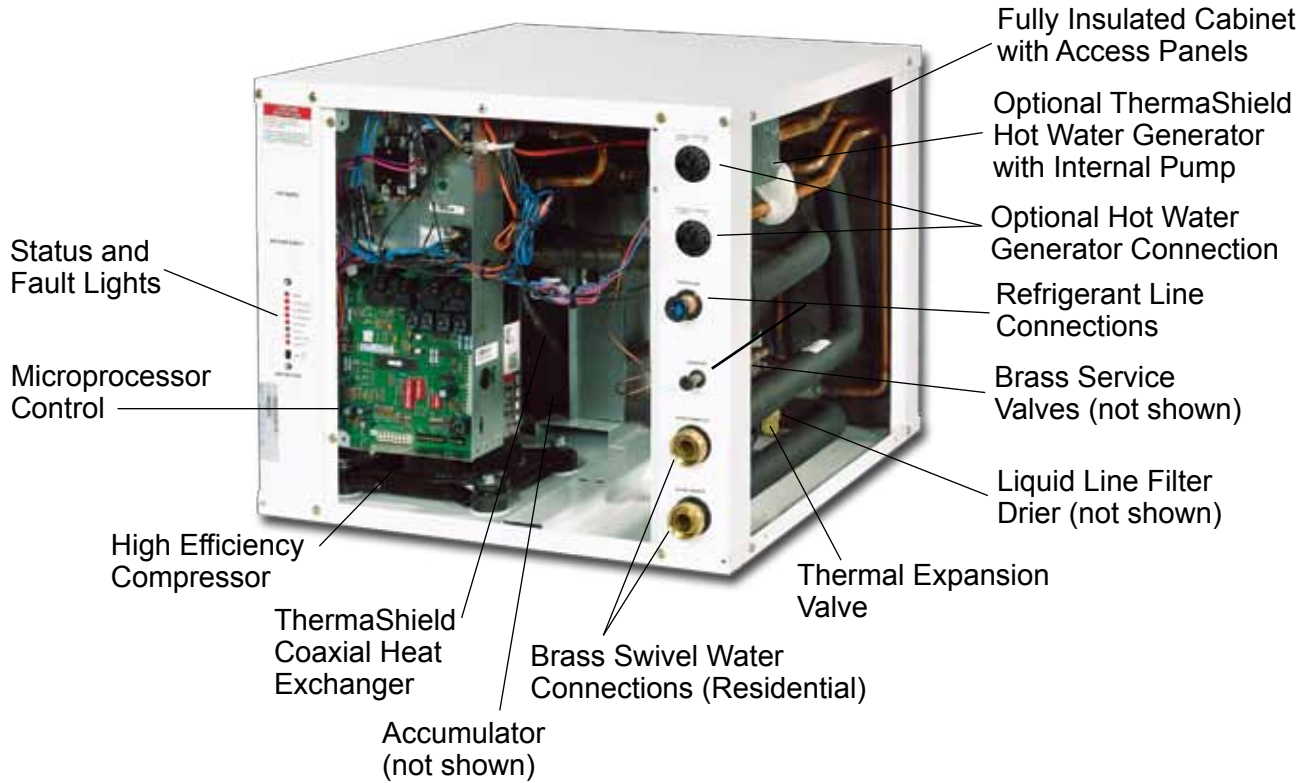

Physical Data

Model	022	030	036	042	048	060	070	026	038	049	064	72
Compressor (1 each)	Single Speed Scroll							Dual Capacity Scroll				
Factory Charge R410a, oz [kg]	56 [1.59]	56 [1.59]	56 [1.59]	74 [2.1]	90 [2.55]	92 [2.61]	108 [3.06]	52 [1.47]	56 [1.59]	90 [2.55]	92 [2.61]	104 [2.95]
Coax and Water Piping												
Water Connections Size - Swivel- in [mm]	1 [25.4]							1 [25.4]				
HWG Connection Size - Sweat (I.D.) - in [mm]	1/2 [12.7]							1/2 [12.7]				
Brass Service Valve - Liquid Line - in [mm]	3/8" [9.525]				1/2" [12.7]			3/8" [9.525]			1/2" [12.7]	
Brass Service Valve - Suction Line - in [mm]	5/8" [15.875]			3/4" [19.05]		7/8" [22.225]		5/8" [15.875]	3/4" [19.05]		7/8" [22.225]	
Coax & Piping Water Volume - gal [l]	0.7 [2.6]	1.0 [3.8]	1.3 [4.9]	1.3 [4.9]	1.6 [6.1]	1.6 [6.1]	2.3 [8.7]	0.7 [2.6]	1.3 [4.9]	1.6 [6.1]	1.6 [6.1]	2.3 [8.7]
Weight - Operating, lb [kg]	164 [74]	174 [79]	212 [96]	213 [97]	246 [112]	251 [114]	292 [132]	189 [186]	236 [107]	250 [113]	271 [123]	290 [132]
Weight - Packaged, lb [kg]	184 [83]	194 [88]	232 [105]	233 [106]	266 [121]	271 [123]	312 [142]	209 [95]	256 [116]	270 [122]	291 [132]	310 [141]

NOTES: All units have TXV expansion devices, and 1/2 in. [12.2 mm] and 3/4 in. [19.1 mm] electrical knockouts.
Brass service valves are sweat type valves.

1/19/11

Dimensional Data

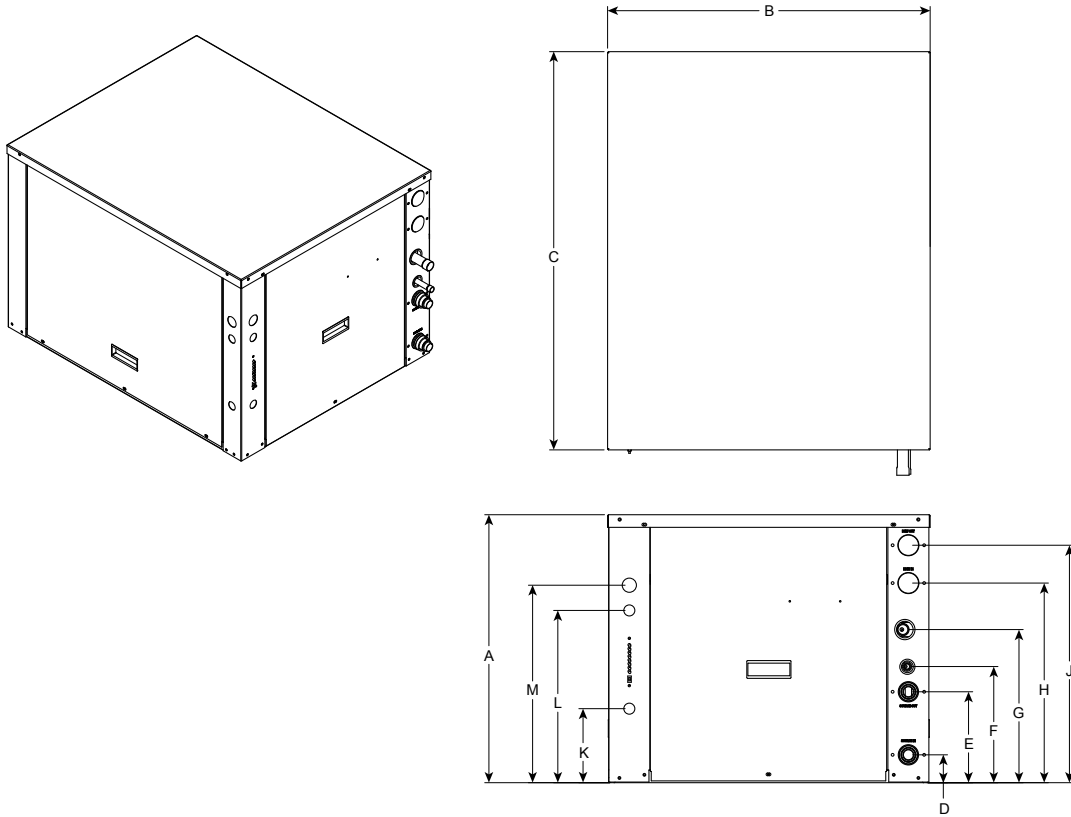

Models	Height	Width	Depth	Water In	Water Out	Service Valve		HWG In	HWG Out	Low Voltage	External Pump	Line Voltage	
						Liquid	Gas						
	A	B	C	D	E	F	G	H	J	K	L	M	
022-030	in.	19.50	22.50	26.50	1.93	6.93	8.44	11.55	13.43	16.43	5.87	13.66	15.66
	cm.	48.90	57.15	67.31	4.90	17.60	21.44	29.34	34.11	41.73	14.91	34.70	39.78
038-072	in.	21.25	25.50	31.50	2.21	7.21	9.21	12.14	15.83	18.83	5.87	13.66	15.66
	cm.	54.00	57.15	80.01	5.61	18.31	23.39	30.84	40.21	47.83	14.91	34.70	39.78

Dimensions are in inches.

7/27/10

Refrigerant line connections extend 2 in. [50.8 mm] beyond the front of the cabinet.

Water lines extend 1.2 in. [30.5 mm] beyond the front of the cabinet.

Electrical Data

Model	Rated Voltage	Voltage Min/Max	Compressor				HWA Pump FLA	Ext Loop FLA	Total Unit FLA	Min Circ Amp	Max Fuse/HACR
			MCC	RLA	LRA	LRA*					
022	208-230/60/1	197/253	14.0	9.0	48.0	17.0	0.4	5.4	14.8	17.1	25
030	208-230/60/1	197/253	20.0	12.8	58.3	21.0	0.4	5.4	18.6	21.8	30
036	208-230/60/1	197/253	22.0	14.1	73.0	26.0	0.4	5.4	19.9	23.4	35
042	208-230/60/1	197/253	26.0	16.6	79.0	28.0	0.4	5.4	22.4	26.6	40
048	208-230/60/1	197/253	31.0	19.8	109.0	38.0	0.4	5.4	25.6	30.6	50
060	208-230/60/1	197/253	41.2	26.4	134.0	47.0	0.4	5.4	32.2	38.8	60
070	208-230/60/1	197/253	47.0	30.1	158.0	55.0	0.4	5.4	35.9	43.4	70
026	208-230/60/1	197/253	16.0	10.2	52.0	18.0	0.4	5.4	16.0	18.6	25
038	208-230/60/1	197/253	26.0	16.6	82.0	29.0	0.4	5.4	22.4	26.6	40
049	208-230/60/1	197/253	33.0	21.1	96.0	34.0	0.4	5.4	26.9	32.2	50
064	208-230/60/1	197/253	40.0	25.6	118.0	41.0	0.4	5.4	31.4	37.8	60
072	208-230/60/1	197/253	42.5	27.2	150.0	53.0	0.4	5.4	33.0	39.8	60

Rated voltage of 208-230/60/1

HACR circuit breaker in USA only

Min/Max Voltage of 197/253

All fuses Class RK-5

* With optional GeoStart

5/6/09

Model Nomenclature - Air Handler

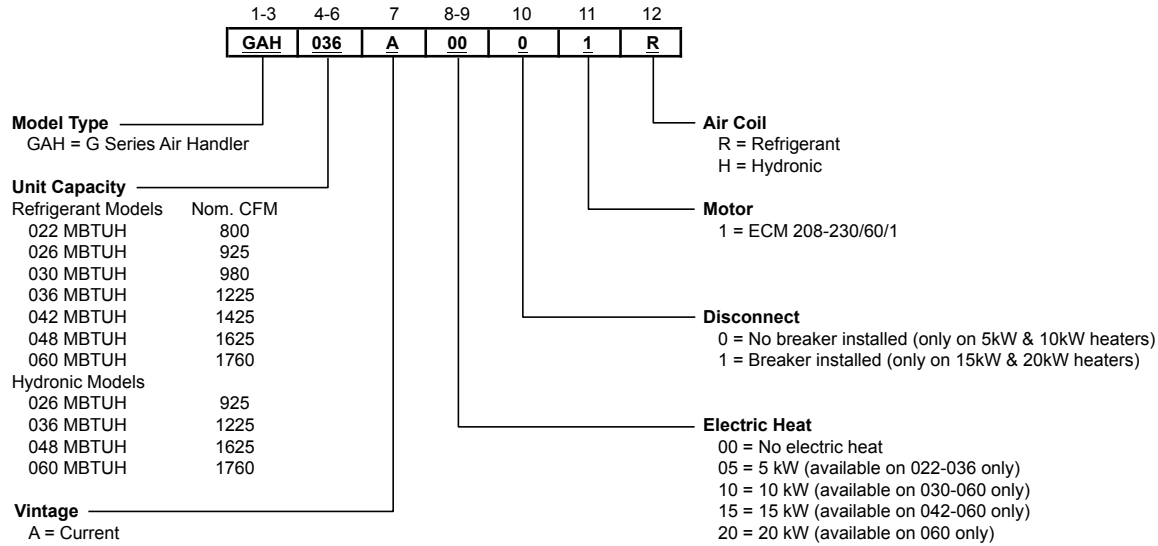

NOTE: Kit GAHBC must be ordered to field convert the GAH042-060 to bottomflow air discharge.

Air Handler Compatibility

Air Handler Sizing Selection

The G Series Air Handlers are designed for R-410A refrigerant and should be matched with the G Series Split compressor section according to the table below.

Air Handler	Indoor Split Model (Single)	Indoor Split Model (Dual Capacity)	Outdoor Split Model (Dual Capacity)	Airflow (CFM)	Electric Heat (kW)
GAH022A***1R	GSZ022	-	-	800	5
GAH026A***1R	-	GTZ026	GTS026	925	5
GAH030A***1R	GSZ030	-	-	980	5, 10
GAH036A***1R	GSZ036	-	-	1225	5, 10
GAH036A***1R	-	GTZ038	GTS038	1225	5, 10
GAH042A***1R	GSZ042	-	-	1425	10, 15
GAH048A***1R	GSZ048	-	-	1625	10, 15
GAH048A***1R	-	GTZ049	GTS049	1625	10, 15
GAH060A***1R	GSZ060	-	-	1760	10, 15, 20
GAH060A***1R	-	GTZ064	GTS064	1760	10, 15, 20
GAH060A***1R	GSZ070	-	-	1760	10, 15, 20
GAH060A***1R	-	GTZ072	GTS072	1760	10, 15, 20

6/9/08

Physical Data - Air Handler

Air Handler Model Number (Refrigerant)		GAH022	GAH026	GAH030	GAH036	GAH042	GAH048	GAH060	
Evaporator Coil	Air Coil Total Face Area, ft2 [m2]	5.83 [0.54]							
	Tube outside diameter - in. [mm]	3/8 [9.52]							
	Number of rows	2				3			
	Fins per inch	12							
	Suction line connection - in. [mm] sweat	5/8 [15.87]				7/8 [22.22]			
	Liquid line connection - in. [mm] sweat	3/8 [9.52]							
Refrigerant		R-410a							
Nominal cooling capacity - tons [kW]		1.8 [6.44]	2.1 [7.59]	2.5 [8.79]	3 [10.55]	3.5 [12.30]	4 [14.06]	5 [17.58]	
Condensate drain connection - (FPT) in. [mm]		3/4 [19.05]							
Blower Wheel Size (Dia x W), in. [mm]		11 x 10 [279 x 254]							
Blower motor type/speeds		ECM variable speed							
Blower motor output - hp [W]		1/2 [373]				1 [746]			
Filter Standard - 1" [51mm] MERV3 disposable, in. [mm]		20 x 24 [508 x 635]							
Electrical characteristics (60hz)		208/230 - 1ph							
Shipping weight - lbs. [kg]		205				210			
Operating weight - lbs. [kg]		195 [88.45]				200 [90.71]			

Line Set Sizes

Unit Size	Air Handler	20 feet		40 feet		60 feet		Factory Charge (oz.)	*Charge Amount with GAH Air Handler (oz.)
		Suction	Liquid	Suction	Liquid	Suction	Liquid		
022	GAH022	5/8" OD	3/8" OD	5/8" OD	3/8" OD	3/4" OD	3/8" OD	56	78
030	GAH030	5/8" OD	3/8" OD	3/4" OD	3/8" OD	3/4" OD	3/8" OD	56	78
036	GAH036	5/8" OD	3/8" OD	3/4" OD	3/8" OD	3/4" OD	1/2" OD	56	86
042	GAH042	3/4" OD	3/8" OD	3/4" OD	3/8" OD	7/8" OD	1/2" OD	74	99
048	GAH048	3/4" OD	3/8" OD	7/8" OD	3/8" OD	7/8" OD	1/2" OD	90	115
060	GAH060	7/8" OD	1/2" OD	7/8" OD	1/2" OD	1-1/8" OD	1/2" OD	92	112
070	GAH060	7/8" OD	1/2" OD	7/8" OD	1/2" OD	1-1/8" OD	1/2" OD	108	132
026	GAH026	5/8" OD	3/8" OD	3/4" OD	3/8" OD	3/4" OD	1/2" OD	52	74
038	GAH036	3/4" OD	3/8" OD	3/4" OD	3/8" OD	3/4" OD	1/2" OD	56	86
049	GAH048	3/4" OD	3/8" OD	7/8" OD	3/8" OD	7/8" OD	1/2" OD	90	115
064	GAH060	7/8" OD	1/2" OD	7/8" OD	1/2" OD	1-1/8" OD	1/2" OD	92	112
072	GAH060	7/8" OD	1/2" OD	7/8" OD	1/2" OD	1-1/8" OD	1/2" OD	104	132

NOTES: * The "Charge Amount with GAH Air Handler" column is based on the charge amount for a GAH Air Handler+Compressor Section/Split. Additional charge will have to be added accordingly for line set length. After Charge is added adjustments can be made to get appropriate subcooling and superheat. Additional charge for R-410A is 0.50 oz. per ft. for 3/8 in. and 1.0 oz. per ft. for 1/2 in. tube. Longer line sets will reduce capacity and efficiency of the system as well as adversely effect system reliability due to poor oil return.

4/6/10

Model Nomenclature - Coil

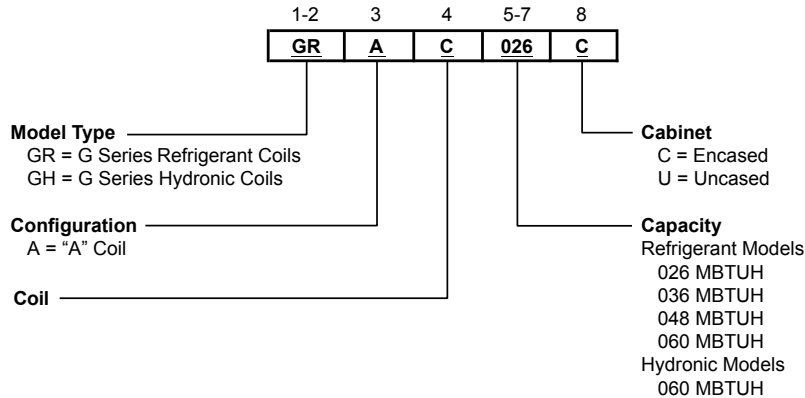

NOTE: All Refrigerant Coils include TXV.

Refrigerant Coil Compatibility

Encased/Uncased Coil	Indoor Split Model (Single)	Indoor Split Model (Dual Capacity)	Outdoor Split Model (Dual Capacity)	Recommended Airflow (CFM)
GRAC026*	GSZ022	-		800
GRAC026*	-	GTZ026	GTS026	925
GRAC026*	GSZ030	-	-	980
GRAC036*	GSZ036	-	-	1225
GRAC036*	-	GTZ038	GTS038	1225
GRAC048*	GSZ042	-	-	1425
GRAC048*	GSZ048	-	-	1625
GRAC048*	-	GTZ049	GTS049	1625
GRAC060*	GSZ060	-	-	1760
GRAC060*	-	GTZ064	GTS064	1760
GRAC060*	GSZ070	-	-	1760
GRAC060*	-	GTZ072	GTS072	1760

7/14/08

Reference Calculations

Heating Calculations:	Cooling Calculations:
$LWT = EWT - \frac{HE}{GPM \times 500}$	$LWT = EWT + \frac{HR}{GPM \times 500}$
$LAT = EAT + \frac{HC}{CFM \times 1.08}$	$LAT (DB) = EAT (DB) - \frac{SC}{CFM \times 1.08}$
$TH = HC + HW$	$LC = TC - SC$
	$S/T = \frac{SC}{TC}$

Legend and Notes

ABBREVIATIONS AND DEFINITIONS:

CFM = airflow, cubic feet/minute	HE = total heat of extraction, MBTUH
EWT = entering water temperature, Fahrenheit	HWC = hot water generator capacity, MBTUH
GPM = water flow in gallons/minute	EER = Energy Efficient Ratio
WPD = water pressure drop, PSI and feet of water	= BTU output/Watt input
EAT = entering air temperature, Fahrenheit (dry bulb/wet bulb)	COP = Coefficient of Performance
HC = air heating capacity, MBTUH	= BTU output/BTU input
TC = total cooling capacity, MBTUH	LWT = leaving water temperature, °F
SC = sensible cooling capacity, MBTUH	LAT = leaving air temperature, °F
kW = total power unit input, kilowatts	TH = total heating capacity, MBTUH
HR = total heat of rejection, MBTUH	LC = latent cooling capacity, MBTUH
	S/T = sensible to total cooling ratio

Hot water generator performance based on 0.4 GPM flow per nominal unit ton at 90°F entering hot water temperature. Performance data does not include water pumping watts and are based upon 15% (by volume) methanol antifreeze solution. Multiple Flow Rates (for EWT) are shown in the capacity data tables. The lowest flow rate shown is used for geothermal open loop/well water systems with a minimum 50°F. The second flow rate shown is the minimum geothermal closed loop flow rate. The third flow rate shown is optimum for geothermal closed loop and the suggested flow rate for boiler tower applications. Interpolation between EWT, GPM and CFM data is permissible. Extrapolation for heating data down to 25°F is permissible. Catalog illustrations cover the general appearance of products at time of publication. We reserve the right to make changes in design and construction at any time without notice.

Operating Limits

Operating Limits	Cooling		Heating	
	(°F)	(°C)	(°F)	(°C)
Air Limits				
Min. Ambient Air	45	7.2	45	7.2
Rated Ambient Air	80	26.7	70	21.1
Max. Ambient Air	100	37.8	85	29.4
Min. Entering Air	50	10.0	40	4.4
Rated Entering Air db/wb	80.6/66.2	27/19	68	20.0
Max. Entering Air db/wb	110/83	43/28.3	80	26.7
Water Limits				
Min. Entering Water	30	-1.1	20	-6.7
Normal Entering Water	50-110	10-43.3	30-70	-1.1
Max. Entering Water	120	48.9	90	32.2

NOTE: Minimum/maximum limits are only for start-up conditions, and are meant for bringing the space up to occupancy temperature. Units are not designed to operate at the minimum/maximum conditions on a regular basis. The operating limits are dependent upon three primary factors: 1) water temperature, 2) return air temperature, and 3) ambient temperature. When any of the factors are at the minimum or maximum levels, the other two factors must be at the normal level for proper and reliable unit operation.

Pressure Drop

Single Speed

Model	GPM	Pressure Drop (psi)				
		30°F	50°F	70°F	90°F	110°F
022	3	0.9	0.9	0.8	0.7	0.7
	4.5	1.7	1.6	1.5	1.4	1.3
	6	2.8	2.7	2.5	2.3	2.2
	8	4.7	4.4	4.1	3.9	3.6
030	4	1.5	1.4	1.3	1.2	1.1
	6	3.0	2.8	2.7	2.5	2.3
	8	5.1	4.8	4.5	4.2	3.9
	10	7.7	7.2	6.8	6.3	5.8
036	5	1.0	1.0	0.9	0.8	0.8
	7	2.1	1.9	1.8	1.7	1.6
	9	3.6	3.3	3.0	2.8	2.6
	12	6.3	5.9	5.5	5.1	4.8
042	5	0.8	0.7	0.7	0.7	0.6
	8	2.1	2.1	1.9	1.8	1.7
	11	4.2	4.1	3.8	3.5	3.3
	14	7.6	6.7	6.3	5.8	5.4
048	6	1.1	1.0	1.0	0.9	0.8
	9	2.3	2.1	2.0	1.9	1.7
	12	3.9	3.7	3.4	3.2	3.0
	16	6.7	6.3	5.9	5.5	5.1
060	9	2.4	2.2	2.1	2.0	1.8
	12	3.9	3.6	3.4	3.2	2.9
	15	5.7	5.3	5.0	4.7	4.3
	20	9.5	8.9	8.3	7.8	7.2
070	12	3.0	2.8	2.6	2.4	2.2
	15	4.4	4.0	3.8	3.5	3.3
	18	6.0	5.5	5.1	4.8	4.4
	24	9.7	9.1	8.5	7.9	7.3

5/30/06

Dual Capacity

Model	GPM	Pressure Drop (psi)				
		30°F	50°F	70°F	90°F	110°F
026 full load	4	1.4	1.3	1.2	1.1	1.0
	6	2.8	2.6	2.4	2.3	2.1
	8	4.7	4.4	4.1	3.8	3.5
	10	7.0	6.6	6.2	5.8	5.3
026 part load	3	0.8	0.7	0.7	0.7	0.6
	5	2.0	1.8	1.7	1.6	1.5
	7	3.6	3.4	3.2	3.0	2.8
	9	5.8	5.5	5.1	4.8	4.4
038 full load	5	1.2	1.2	1.1	1.0	1.0
	7	2.2	2.1	1.9	1.8	1.7
	9	3.4	3.2	3.0	2.8	2.6
	11	4.9	4.6	4.3	4	3.7
038 part load	4	0.9	0.8	0.8	0.7	0.7
	6	1.7	1.6	1.5	1.4	1.3
	8	2.8	2.6	2.5	2.3	2.1
	10	4.2	3.9	3.7	3.4	3.2
049 full load	6	1.2	1.2	1.1	1.0	1.0
	9	2.4	2.2	2.1	2.0	1.8
	12	3.9	3.6	3.4	3.2	2.9
	15	5.7	5.3	5	4.7	4.3
049 part load	5	0.9	0.9	0.8	0.8	0.7
	8	2.0	1.8	1.7	1.6	1.5
	11	3.4	3.1	2.9	2.8	2.5
	14	5.0	4.7	4.4	4.1	3.8
064 full load	8	1.8	1.7	1.6	1.4	1.3
	12	3.8	3.5	3.3	3.0	2.8
	16	6.5	6.0	5.6	5.2	4.8
	20	9.7	9.1	8.5	8.0	7.4
064 part load	6	1.0	0.9	0.9	0.8	0.8
	10	2.6	2.5	2.3	2.1	2.0
	14	5.0	4.7	4.4	4.1	3.8
	18	8.1	7.6	7.1	6.6	6.1
072 full load	12	3.2	3.0	2.8	2.6	2.4
	15	4.5	4.2	4.0	3.7	3.4
	18	6.0	5.7	5.3	4.9	4.6
	21	7.8	7.3	6.8	6.4	5.9
072 part load	10	2.3	2.1	2.0	1.9	1.7
	13	3.6	3.3	3.0	2.8	2.6
	16	5.0	4.6	4.3	4.0	3.7
	19	6.5	6.2	5.8	5.4	5.0

5/30/06

GSZ022 - Performance Data

700 CFM Rated Airflow

EWT °F	Flow gpm	WPD		HEATING - EAT 70°F							COOLING - EAT 80/67 °F																
		PSI	FT	Airflow cfm	HC kBtuh	Power kW	HE kBtuh	LAT °F	COP	HWC kBtuh	Airflow cfm	TC kBtuh	SC kBtuh	S/T Ratio	Power kW	HR kBtuh	EER	HWC kBtuh									
20	3.0	0.9	2.2	Operation not recommended							Operation not recommended																
	4.5	1.8	4.2	Operation not recommended							Operation not recommended																
	6.0	2.9	6.8	600	12.0	1.17	8.0	88.5	2.99	1.6	700	12.1	1.18	8.1	86.1	3.00	1.5										
30	3.0	0.9	2.1	Operation not recommended							Operation not recommended																
	4.5	1.7	4.0	600	14.1	1.17	10.0	91.7	3.51	1.7	700	14.3	1.18	10.3	92.1	3.55	1.8	600	21.2	14.3	0.68	0.63	23.3	33.8	-		
	6.0	2.8	6.6	600	14.3	1.18	10.3	92.1	3.55	1.8	700	14.5	1.19	10.5	89.2	3.57	1.6	600	21.3	14.3	0.67	0.61	23.4	35.0	-		
				700	21.8	15.6	0.72	0.64	24.0	34.1	-																
40	3.0	0.9	2.0	Operation not recommended							Operation not recommended																
	4.5	1.7	3.9	600	16.6	1.19	12.5	95.6	4.07	1.9	700	16.9	1.20	12.8	92.3	4.14	1.8	600	21.9	14.3	0.65	0.7	24.2	31.9	-		
	6.0	2.8	6.4	600	16.8	1.21	12.7	96.0	4.09	2.0	700	17.2	1.21	13.1	92.7	4.17	1.8	600	22.1	14.3	0.65	0.7	24.3	33.2	-		
				700	17.2	1.21	13.1	92.7	4.17	1.8	700	22.5	15.6	0.69	0.7	24.9	32.4	-									
50	3.0	0.9	2.0	600	18.0	1.21	13.9	97.8	4.37	2.1	700	18.4	1.21	14.2	94.3	4.45	1.9	600	22.3	14.0	0.63	0.8	25.1	27.8	1.0		
	4.5	1.6	3.8	600	18.9	1.23	14.7	99.2	4.49	2.2	700	19.3	1.23	15.1	95.5	4.57	2.0	600	22.5	14.2	0.63	0.8	25.2	29.5	0.9		
	6.0	2.7	6.2	600	19.2	1.25	14.9	99.6	4.49	2.2	700	19.6	1.24	15.4	96.0	4.63	2.0	600	22.8	14.2	0.62	0.7	25.3	30.8	0.9		
				700	19.6	1.24	15.4	96.0	4.63	2.0	700	23.2	15.5	0.67	0.8	25.9	30.1	1.0									
60	3.0	0.8	1.9	600	20.3	1.24	16.1	101.3	4.78	2.3	700	20.8	1.23	16.6	97.5	4.94	2.2	600	21.6	14.0	0.65	0.9	24.7	23.9	1.2		
	4.5	1.6	3.7	600	21.3	1.27	16.9	102.8	4.90	2.4	700	21.8	1.26	17.5	98.8	5.06	2.2	600	21.8	14.1	0.65	0.9	24.7	25.5	1.1		
	6.0	2.6	6.0	600	21.6	1.29	17.2	103.4	4.92	2.5	700	22.2	1.27	17.8	99.3	5.11	2.3	600	22.0	14.1	0.64	0.8	24.9	26.5	1.0		
				700	22.2	1.27	17.8	99.3	5.11	2.3	700	22.5	15.3	0.68	0.9	25.4	26.1	1.1									
70	3.0	0.8	1.8	600	22.7	1.31	18.2	105.0	5.09	2.6	700	23.2	1.28	18.8	100.7	5.31	2.4	600	21.3	13.9	0.65	1.0	24.8	20.9	1.5		
	4.5	1.5	3.6	600	23.7	1.33	19.1	106.5	5.21	2.7	700	24.4	1.31	19.9	102.2	5.44	2.5	600	21.5	13.9	0.65	1.0	24.8	22.3	1.4		
	6.0	2.5	5.8	600	24.1	1.35	19.5	107.2	5.24	2.8	700	24.7	1.32	20.2	102.7	5.48	2.6	600	21.7	13.9	0.64	0.9	24.9	23.1	1.3		
				700	24.7	1.32	20.2	102.7	5.48	2.6	700	22.2	15.2	0.69	1.0	25.5	22.8	1.4									
80	3.0	0.8	1.8	600	24.7	1.35	20.0	108.0	5.35	2.9	700	25.4	1.31	20.9	103.6	5.65	2.7	600	20.4	13.5	0.66	1.2	24.4	17.6	1.8		
	4.5	1.5	3.4	600	25.7	1.38	21.0	109.7	5.47	3.0	700	26.6	1.34	22.0	105.2	5.79	2.8	600	20.6	13.6	0.66	1.1	24.3	18.8	1.7		
	6.0	2.4	5.6	600	26.2	1.40	21.4	110.4	5.50	3.1	700	27.0	1.36	22.4	105.7	5.83	2.9	600	20.8	13.6	0.65	1.1	24.5	19.6	1.6		
				700	27.0	1.36	22.4	105.7	5.83	2.9	700	21.2	14.8	0.70	1.1	25.0	19.3	1.8									
90	3.0	0.7	1.7	600	26.7	1.42	21.8	111.2	5.50	3.3	700	27.6	1.38	22.9	106.5	5.86	3.0	600	18.9	13.2	0.70	1.3	23.3	14.3	2.3		
	4.5	1.4	3.3	600	27.8	1.46	22.9	113.0	5.61	3.4	700	28.8	1.40	24.0	108.1	6.02	3.1	600	19.3	14.3	0.74	1.4	23.9	14.2	2.4		
	6.0	2.3	5.4	600	28.3	1.47	23.3	113.6	5.63	3.5	700	29.4	1.42	24.5	108.8	6.05	3.2	600	19.0	13.3	0.70	1.2	23.3	15.2	2.1		
				700	28.8	1.40	24.0	108.1	6.02	3.1	700	19.5	14.5	0.74	1.3	23.8	15.2	2.3	600	19.3	13.3	0.69	1.2	23.4	16.0	2.0	
				700	19.6	14.5	0.74	1.2	23.9	15.7	2.2																
100	3.0	0.7	1.7	Operation not recommended							Operation not recommended																
	4.5	1.4	3.2	Operation not recommended							Operation not recommended																
	6.0	2.2	5.2	Operation not recommended							Operation not recommended																
				600	18.3	13.0	0.71	1.41	23.1	12.9	2.6	700	18.6	14.1	0.76	1.45	23.6	12.8	2.9								
				600	18.5	13.0	0.70	1.37	23.1	13.5	2.5	700	18.8	14.1	0.75	1.41	23.6	13.3	2.7								
110	3.0	0.7	1.6	Operation not recommended							Operation not recommended																
	4.5	1.3	3.1	Operation not recommended							Operation not recommended																
	6.0	2.2	5.0	Operation not recommended							Operation not recommended																
				600	16.4	12.5	0.76	1.59	21.8	10.3	3.2	700	16.7	13.6	0.81	1.64	22.3	10.2	3.5								
				600	16.6	12.5	0.75	1.54	21.8	10.7	3.0	700	16.9	13.6	0.80	1.59	22.3	10.6	3.3								
120	3.0	0.7	1.5	Operation not recommended							Operation not recommended																
	4.5	1.3	2.9	Operation not recommended							Operation not recommended																
	6.0	2.1	4.8	Operation not recommended							Operation not recommended																
				600	15.2	12.1	0.80	1.80	21.3	8.4	3.9	700	15.5	13.1	0.85	1.85	21.8	8.4	4.2								
				600	15.3	12.1	0.79	1.75	21.3	8.8	3.6	700	15.6	13.1	0.84	1.80	21.8	8.7	4.0								

GSZ030 - Performance Data

900 CFM Rated Airflow

EWT °F	Flow gpm	WPD		HEATING - EAT 70°F							COOLING - EAT 80/67 °F														
		PSI	FT	Airflow cfm	HC kBtuh	Power kW	HE kBtuh	LAT °F	COP	HWC kBtuh	Airflow cfm	TC kBtuh	SC kBtuh	S/T Ratio	Power kW	HR kBtuh	EER	HWC kBtuh							
20	4.0	1.5	3.5	Operation not recommended							Operation not recommended														
	6.0	3.1	7.2	Operation not recommended							Operation not recommended														
	8.0	5.2	12.1	700	16.5	1.54	11.3	91.9	3.15	2.1	900	16.8	1.57	11.5	87.3	3.14	1.9								
30	4.0	1.5	3.4	Operation not recommended							Operation not recommended														
	6.0	3.0	7.0	700	19.0	1.53	13.7	95.1	3.64	2.3	900	19.4	1.56	14.1	89.9	3.64	2.1	700	23.6	15.1	0.64	0.83	26.5	28.6	-
	8.0	5.1	11.8	700	19.5	1.54	14.2	95.7	3.69	2.4	900	19.8	1.57	14.4	90.3	3.68	2.1	700	23.8	15.1	0.63	0.81	26.6	29.3	-
40	4.0	1.4	3.3	Operation not recommended							Operation not recommended														
	6.0	2.9	6.8	700	22.2	1.58	16.8	99.4	4.12	2.6	900	22.7	1.60	17.3	93.4	4.16	2.3	700	25.6	16.3	0.64	0.91	28.7	28.3	-
	8.0	4.9	11.4	700	22.7	1.60	17.3	100.1	4.17	2.6	900	23.2	1.62	17.7	93.9	4.21	2.4	700	25.8	16.3	0.63	0.89	28.9	29.1	-
50	4.0	1.4	3.2	700	24.3	1.62	18.8	102.2	4.39	2.8	900	24.9	1.64	19.3	95.6	4.45	2.6	700	27.4	17.5	0.64	1.05	30.9	26.1	1.3
	6.0	2.8	6.6	700	25.1	1.63	19.6	103.2	4.52	2.9	900	25.8	1.64	20.2	96.5	4.59	2.6	700	27.4	17.6	0.64	1.01	30.9	27.3	1.2
	8.0	4.8	11.1	700	25.7	1.65	20.1	104.0	4.56	3.0	900	26.3	1.66	20.7	97.1	4.65	2.7	700	27.7	17.6	0.64	0.99	31.1	28.1	1.1
60	4.0	1.4	3.1	700	27.3	1.69	21.5	106.1	4.73	3.1	900	28.0	1.69	22.2	98.8	4.85	2.9	700	26.7	17.2	0.64	1.15	30.6	23.3	1.5
	6.0	2.8	6.4	700	28.2	1.71	22.4	107.3	4.84	3.2	900	29.0	1.70	23.2	99.9	4.99	3.0	700	27.5	19.3	0.70	1.22	31.7	22.6	1.6
	8.0	4.6	10.7	700	28.8	1.73	22.9	108.1	4.87	3.3	900	29.6	1.72	23.7	100.4	5.03	3.0	700	26.8	17.3	0.65	1.11	30.5	24.2	1.4
70	4.0	1.3	3.0	700	30.4	1.78	24.3	110.2	5.01	3.5	900	31.2	1.77	25.2	102.1	5.17	3.2	700	27.6	19.3	0.70	1.17	31.6	23.6	1.6
	6.0	2.7	6.2	700	31.4	1.80	25.2	111.5	5.10	3.6	900	32.3	1.78	26.3	103.3	5.31	3.3	700	27.1	17.3	0.64	1.08	30.7	25.0	1.3
	8.0	4.5	10.4	700	31.9	1.83	25.7	112.3	5.13	3.7	900	32.9	1.80	26.7	103.9	5.34	3.4	700	27.9	19.4	0.69	1.14	31.8	24.4	1.5
80	4.0	1.3	2.9	700	32.8	1.86	26.5	113.4	5.17	3.9	900	33.9	1.83	27.6	104.9	5.42	3.6	700	27.2	17.5	0.64	1.21	31.4	22.5	1.7
	6.0	2.6	5.9	700	34.5	1.91	28.0	115.6	5.29	4.2	900	35.7	1.88	29.3	106.7	5.57	3.9	700	26.9	19.6	0.70	1.28	32.4	22.0	1.8
	8.0	4.3	10.0	700	35.1	1.85	28.8	106.2	5.55	3.7	900	35.7	1.88	29.3	106.7	5.57	3.9	700	25.7	17.2	0.67	1.43	30.6	18.0	2.4
90	4.0	1.2	2.8	700	35.3	1.96	28.7	116.7	5.28	4.4	900	36.6	1.91	30.1	107.7	5.60	4.1	700	25.9	17.3	0.67	1.38	30.6	18.7	2.2
	6.0	2.5	5.7	700	36.7	1.99	29.9	118.5	5.40	4.5	900	38.0	1.94	31.4	109.1	5.73	4.2	700	26.5	19.3	0.73	1.50	31.7	17.7	2.5
	8.0	4.2	9.6	700	37.1	2.02	30.3	119.1	5.39	4.7	900	38.6	1.97	31.9	109.7	5.75	4.3	700	25.0	18.3	0.73	1.57	30.3	15.9	2.9
100	4.0	1.2	2.7	Operation not recommended							Operation not recommended														
	6.0	2.4	5.5	Operation not recommended							Operation not recommended														
	8.0	4.0	9.3	700	32.8	1.86	26.5	113.4	5.17	3.9	900	33.9	1.83	27.6	104.9	5.42	3.6	700	23.1	16.4	0.71	1.70	28.9	13.6	3.2
110	4.0	1.1	2.6	Operation not recommended							Operation not recommended														
	6.0	2.3	5.3	Operation not recommended							Operation not recommended														
	8.0	3.9	8.9	700	19.5	1.53	13.7	95.1	3.64	2.3	900	20.1	1.56	14.1	89.9	3.64	2.1	700	19.6	15.4	0.78	1.90	26.1	10.4	3.9
120	4.0	1.1	2.5	Operation not recommended							Operation not recommended														
	6.0	2.2	5.1	Operation not recommended							Operation not recommended														
	8.0	3.7	8.6	700	18.9	1.48	12.8	92.8	3.58	2.2	900	19.4	1.51	13.3	88.8	3.61	2.1	700	20.3	17.1	0.84	1.95	26.9	10.4	4.3

GSZ036 - Performance Data

1250 CFM Rated Airflow

EWT °F	Flow gpm	WPD		HEATING - EAT 70°F							COOLING - EAT 80/67 °F														
		PSI	FT	Airflow cfm	HC kBTuh	Power kW	HE kBTuh	LAT °F	COP	HWC kBTuh	Airflow cfm	TC kBTuh	SC kBTuh	S/T Ratio	Power kW	HR kBTuh	EER	HWC kBTuh							
20	5.0	1.0	2.4	Operation not recommended							Operation not recommended														
	7.0	2.1	4.9	Operation not recommended							Operation not recommended														
	9.0	3.6	8.2	1050	20.1	1.81	14.0	87.7	3.27	2.6	1250	20.5	1.84	14.2	85.2	3.26	2.3								
30	5.0	1.0	2.3	Operation not recommended							Operation not recommended														
	7.0	2.1	4.7	1050	22.7	1.83	16.5	90.0	3.65	2.8	1250	23.2	1.86	16.9	87.2	3.65	2.5	1050	27.1	17.5	0.65	1.02	30.6	26.5	-
	9.0	3.5	8.0	1050	23.3	1.84	17.0	90.6	3.71	2.9	1250	23.7	1.88	17.3	87.6	3.69	2.6	1050	27.3	17.4	0.64	1.00	30.7	27.2	-
40	5.0	1.0	2.3	Operation not recommended							Operation not recommended														
	7.0	2.0	4.6	1050	28.7	1.91	22.2	95.3	4.41	3.4	1250	27.5	1.91	21.0	90.4	4.23	2.8	1050	29.7	19.5	0.66	1.12	33.5	26.5	-
	9.0	3.4	7.8	1050	27.5	1.90	21.0	94.3	4.24	3.2	1250	28.1	1.93	21.6	90.8	4.28	2.9	1050	30.0	19.4	0.65	1.10	33.7	27.3	-
50	5.0	1.0	2.2	1050	28.7	1.91	22.2	95.3	4.41	3.4	1250	29.4	1.93	22.8	91.8	4.47	3.1	1050	32.0	21.0	0.66	1.29	36.4	24.8	1.5
	7.0	1.9	4.5	1050	29.7	1.92	23.1	96.2	4.54	3.5	1250	30.4	1.93	23.8	92.5	4.61	3.2	1050	32.1	21.2	0.66	1.24	36.3	25.8	1.4
	9.0	3.3	7.5	1050	30.3	1.94	23.7	96.8	4.58	3.6	1250	31.1	1.95	24.4	93.0	4.67	3.3	1050	33.0	23.7	0.71	1.29	37.8	25.9	1.5
60	5.0	0.9	2.1	1050	32.9	1.98	26.1	99.0	4.86	3.8	1250	33.8	1.99	27.0	95.0	4.98	3.5	1050	31.7	21.5	0.68	1.41	36.5	22.5	1.8
	7.0	1.9	4.3	1050	34.0	2.00	27.2	100.0	4.97	3.9	1250	35.0	2.00	28.1	95.9	5.12	3.6	1050	32.7	24.2	0.74	1.49	37.8	21.9	1.9
	9.0	3.1	7.3	1050	35.0	2.00	28.1	95.9	5.12	3.6	1250	34.7	2.03	27.8	100.6	5.01	4.0	1050	31.8	21.6	0.68	1.36	36.4	23.5	1.7
70	5.0	0.9	2.1	1050	32.9	1.98	26.1	99.0	4.86	3.8	1250	33.8	1.99	27.0	95.0	4.98	3.5	1050	32.1	21.6	0.67	1.33	36.7	24.2	1.6
	7.0	1.8	4.2	1050	37.0	2.05	30.0	102.7	5.28	4.4	1250	38.2	2.03	31.2	98.3	5.51	4.0	1050	32.2	24.3	0.73	1.40	37.9	23.6	1.8
	9.0	3.0	7.0	1050	37.7	2.08	30.6	103.2	5.31	4.5	1250	35.6	2.02	28.7	96.4	5.17	3.7	1050	32.8	24.2	0.74	1.43	37.7	22.8	1.8
80	5.0	0.9	2.0	1050	35.8	2.01	30.0	97.3	5.36	3.9	1250	39.5	2.11	32.3	104.9	5.50	4.8	1050	32.2	22.4	0.69	1.56	37.5	20.6	2.3
	7.0	1.7	4.0	1050	37.0	2.05	30.0	102.7	5.28	4.4	1250	40.8	2.08	33.7	100.2	5.76	4.4	1050	33.2	25.1	0.76	1.65	38.8	20.1	2.4
	9.0	2.9	6.8	1050	41.0	2.14	33.7	106.1	5.61	4.9	1250	37.7	2.08	30.6	103.2	5.31	4.5	1050	32.3	22.5	0.70	1.50	37.4	21.5	2.1
90	5.0	0.8	1.9	1050	38.2	2.03	31.2	98.3	5.51	4.0	1250	42.3	2.10	35.2	101.4	5.90	4.5	1050	33.2	25.1	0.75	1.58	38.7	21.0	2.3
	7.0	1.7	3.9	1050	41.6	2.17	34.2	106.7	5.62	5.1	1250	43.0	2.13	35.7	101.9	5.93	4.7	1050	32.6	22.5	0.69	1.47	37.6	22.2	2.0
	9.0	2.8	6.6	1050	43.0	2.13	35.7	101.9	5.93	4.7	1250	41.6	2.17	34.2	106.7	5.62	5.1	1050	32.6	22.5	0.69	1.47	37.6	22.2	2.0
100	5.0	0.8	1.8	Operation not recommended							Operation not recommended														
	7.0	1.6	3.8	Operation not recommended							Operation not recommended														
	9.0	2.7	6.3	1050	43.9	2.22	36.3	108.7	5.80	5.7	1250	45.6	2.16	38.2	103.8	6.19	5.2	1050	29.9	21.8	0.73	1.94	36.5	15.4	3.0
110	5.0	0.8	1.8	Operation not recommended							Operation not recommended														
	7.0	1.6	3.6	Operation not recommended							Operation not recommended														
	9.0	2.6	6.1	1050	45.6	2.16	38.2	103.8	6.19	5.2	1250	29.9	21.8	0.73	1.94	36.5	15.4	3.0							
120	5.0	0.7	1.7	Operation not recommended							Operation not recommended														
	7.0	1.5	3.5	Operation not recommended							Operation not recommended														
	9.0	2.5	5.8	1050	24.3	19.8	0.81	2.56	33.1	9.5	5.9	1250	25.1	22.0	0.88	2.62	34.0	9.6	6.4						

GSZ042 - Performance Data

1350 CFM Rated Airflow

EWT °F	Flow gpm	WPD		HEATING - EAT 70°F							COOLING - EAT 80/67 °F														
		PSI	FT	Airflow cfm	HC kBtuh	Power kW	HE kBtuh	LAT °F	COP	HWC kBtuh	Airflow cfm	TC kBtuh	SC kBtuh	S/T Ratio	Power kW	HR kBtuh	EER	HWC kBtuh							
20	5.0	0.8	1.9	Operation not recommended							Operation not recommended														
	8.0	2.3	5.3	Operation not recommended							Operation not recommended														
	11.0	4.4	10.3	1150	23.3	2.22	15.8	88.8	3.08	3.9	1350	23.6	2.20	16.1	86.2	3.14	3.6								
30	5.0	0.8	1.8	Operation not recommended							Operation not recommended														
	8.0	2.2	5.1	1150	27.1	2.26	19.4	91.8	3.52	4.2	1350	27.4	2.24	19.8	88.8	3.59	3.8	1150	37.2	23.1	0.62	1.40	42.0	26.6	-
	11.0	4.3	10.0	1150	27.5	2.26	19.8	92.1	3.57	4.3	1350	27.8	2.24	20.2	89.1	3.64	3.9	1150	37.6	23.1	0.62	1.36	42.2	27.6	-
40	5.0	0.8	1.8	Operation not recommended							Operation not recommended														
	8.0	2.1	4.9	1150	30.9	2.35	22.9	94.9	3.85	4.6	1350	31.3	2.31	23.5	91.5	3.97	4.2	1150	38.8	24.7	0.64	1.49	43.9	26.0	-
	11.0	4.2	9.7	1150	31.4	2.36	23.4	95.3	3.90	4.7	1350	31.9	2.32	24.0	91.9	4.03	4.3	1150	39.2	24.7	0.63	1.45	44.2	27.1	-
50	5.0	0.7	1.7	1150	33.2	2.36	25.2	96.7	4.12	5.0	1350	33.8	2.32	25.9	93.2	4.27	4.6	1150	39.5	25.5	0.65	1.69	45.2	23.4	2.3
	8.0	2.1	4.8	1150	34.6	2.42	26.3	97.8	4.19	5.1	1350	35.2	2.36	27.1	94.1	4.36	4.7	1150	39.9	25.8	0.65	1.61	45.4	24.8	2.1
	11.0	4.1	9.4	1150	35.3	2.43	27.0	98.4	4.25	5.3	1350	35.9	2.38	27.8	94.6	4.43	4.8	1150	40.3	25.8	0.64	1.56	45.6	25.8	2.0
60	5.0	0.7	1.7	1150	36.4	2.43	28.1	99.3	4.39	5.6	1350	37.1	2.37	29.1	95.5	4.60	5.1	1150	39.4	26.2	0.66	1.86	45.7	21.2	2.8
	8.0	2.0	4.6	1150	38.0	2.50	29.5	100.6	4.45	5.7	1350	38.9	2.43	30.6	96.6	4.69	5.3	1150	39.9	26.4	0.66	1.77	45.9	22.5	2.6
	11.0	3.9	9.1	1150	38.9	2.53	30.3	101.4	4.51	5.9	1350	39.8	2.45	31.5	97.3	4.76	5.4	1150	40.3	26.4	0.66	1.72	46.1	23.5	2.4
70	5.0	0.7	1.6	1150	39.5	2.51	31.0	101.8	4.61	6.2	1350	40.4	2.43	32.1	97.7	4.88	5.8	1150	39.4	26.2	0.66	1.86	45.7	21.2	2.8
	8.0	1.9	4.5	1150	41.4	2.60	32.6	103.3	4.67	6.4	1350	42.4	2.50	33.9	99.1	4.96	5.9	1150	39.5	27.0	0.68	2.05	46.5	19.2	3.5
	11.0	3.8	8.8	1150	42.5	2.63	33.5	104.2	4.73	6.6	1350	43.6	2.53	34.9	99.9	5.05	6.1	1150	40.1	27.3	0.68	1.95	46.8	20.6	3.3
80	5.0	0.7	1.6	1150	42.5	2.55	33.8	104.2	4.88	7.0	1350	43.6	2.45	35.2	99.9	5.22	6.5	1150	40.5	27.3	0.67	1.89	47.0	21.4	3.0
	8.0	1.9	4.3	1150	44.7	2.66	35.6	106.0	4.93	7.2	1350	45.9	2.54	37.3	101.5	5.30	6.7	1150	40.3	26.4	0.66	1.72	46.1	23.5	2.4
	11.0	3.7	8.5	1150	45.9	2.69	36.8	107.0	5.00	7.5	1350	47.3	2.57	38.5	102.4	5.39	6.9	1150	39.9	26.7	0.68	2.10	46.3	18.6	3.8
90	5.0	0.7	1.5	1150	45.3	2.60	36.4	106.5	5.11	7.9	1350	46.6	2.48	38.2	102.0	5.51	7.3	1150	40.4	26.4	0.66	1.72	46.1	23.5	2.4
	8.0	1.8	4.2	1150	47.8	2.72	38.5	108.5	5.15	8.1	1350	49.3	2.58	40.5	103.8	5.59	7.5	1150	38.0	26.4	0.69	2.29	45.8	16.6	4.4
	11.0	3.5	8.2	1150	49.3	2.77	39.9	109.7	5.22	8.4	1350	50.9	2.62	42.0	104.9	5.69	7.8	1150	39.3	29.6	0.75	2.39	47.4	16.5	4.7
100	5.0	0.6	1.5	Operation not recommended							Operation not recommended														
	8.0	1.7	4.0	Operation not recommended							Operation not recommended														
	11.0	3.4	7.9	Operation not recommended							Operation not recommended														
110	5.0	0.6	1.4	Operation not recommended							Operation not recommended														
	8.0	1.7	3.9	Operation not recommended							Operation not recommended														
	11.0	3.3	7.6	Operation not recommended							Operation not recommended														
120	5.0	0.6	1.3	Operation not recommended							Operation not recommended														
	8.0	1.6	3.7	Operation not recommended							Operation not recommended														
	11.0	3.2	7.3	Operation not recommended							Operation not recommended														

GSZ048 - Performance Data

1500 CFM Rated Airflow

EWT °F	Flow gpm	WPD		HEATING - EAT 70°F							COOLING - EAT 80/67 °F																						
		PSI	FT	Airflow cfm	HC kBTuh	Power kW	HE kBTuh	LAT °F	COP	HWC kBTuh	Airflow cfm	TC kBTuh	SC kBTuh	S/T Ratio	Power kW	HR kBTuh	EER	HWC kBTuh															
20	6.0	1.1	2.6	Operation not recommended							Operation not recommended																						
	9.0	2.3	5.4	Operation not recommended							Operation not recommended																						
	12.0	4.0	9.2	1300	31.6	2.84	21.9	92.5	3.26	5.3	1500	32.0	2.82	22.4	89.7	3.33	4.8																
30	6.0	1.1	2.5	Operation not recommended							Operation not recommended																						
	9.0	2.3	5.3	1300	36.3	2.92	26.3	95.8	3.63	5.6	1500	36.7	2.90	26.8	92.6	3.71	5.2	1300	47.5	29.7	0.63	1.61	53.0	29.5	-	1500	49.7	33.4	0.67	1.71	55.6	29.2	-
	12.0	3.9	9.0	1300	36.8	2.93	26.8	96.2	3.68	5.8	1500	37.2	2.90	27.3	93.0	3.76	5.3	1300	48.0	29.7	0.62	1.57	53.3	30.7	-	1500	50.3	33.4	0.66	1.66	55.9	30.3	-
40	6.0	1.1	2.5	Operation not recommended							Operation not recommended																						
	9.0	2.2	5.1	1300	41.7	3.05	31.3	99.7	4.00	6.2	1500	42.2	3.00	32.0	96.1	4.13	5.7	1300	49.9	31.4	0.63	1.72	55.7	29.0	-	1500	51.6	35.3	0.68	1.87	57.9	27.6	-
	12.0	3.8	8.7	1300	42.4	3.06	31.9	100.2	4.06	6.4	1500	43.0	3.01	32.7	96.5	4.19	5.8	1300	49.9	31.4	0.63	1.72	55.7	29.0	-	1500	52.1	35.3	0.68	1.81	58.3	28.7	-
50	6.0	1.0	2.4	1300	44.7	3.09	34.1	101.8	4.24	6.7	1500	45.4	3.02	35.1	98.0	4.40	6.2	1300	50.4	32.6	0.65	2.06	57.5	24.5	2.8	1500	52.5	36.6	0.70	2.17	59.9	24.2	3.0
	9.0	2.1	4.9	1300	46.5	3.16	35.7	103.1	4.31	6.9	1500	47.3	3.08	36.7	99.2	4.49	6.4	1300	51.0	32.9	0.65	1.97	57.7	25.9	2.6	1500	53.1	37.0	0.70	2.07	60.1	25.7	2.9
	12.0	3.7	8.4	1300	47.4	3.18	36.6	103.8	4.37	7.2	1500	48.2	3.10	37.7	99.8	4.56	6.5	1300	51.5	32.9	0.64	1.91	58.0	27.0	2.5	1500	53.6	37.0	0.69	2.01	60.5	26.7	2.7
60	6.0	1.0	2.3	1300	49.1	3.18	38.2	105.0	4.52	7.6	1500	50.0	3.10	39.5	100.9	4.74	7.0	1300	49.2	32.2	0.65	2.29	57.0	21.5	3.5	1500	51.2	36.2	0.71	2.40	59.3	21.3	3.7
	9.0	2.1	4.8	1300	51.3	3.28	40.1	106.5	4.59	7.8	1500	52.3	3.18	41.5	102.3	4.83	7.2	1300	49.9	32.5	0.65	2.18	57.3	22.9	3.2	1500	51.8	36.6	0.71	2.28	59.6	22.7	3.5
	12.0	3.5	8.2	1300	52.5	3.31	41.2	107.4	4.65	8.0	1500	53.6	3.20	42.7	103.1	4.90	7.4	1300	50.4	32.5	0.65	2.11	57.6	23.8	3.0	1500	52.3	36.6	0.70	2.22	59.9	23.6	3.3
70	6.0	1.0	2.2	1300	53.6	3.29	42.4	108.2	4.78	8.5	1500	54.7	3.17	43.9	103.8	5.05	7.9	1300	49.0	32.6	0.66	2.56	57.8	19.1	4.3	1500	50.8	36.6	0.72	2.68	59.9	18.9	4.6
	9.0	2.0	4.6	1300	56.1	3.40	44.5	110.0	4.84	8.8	1500	57.4	3.27	46.3	105.5	5.14	8.1	1300	49.8	32.9	0.66	2.43	58.1	20.5	4.1	1500	51.6	37.0	0.72	2.55	60.3	20.3	4.4
	12.0	3.4	7.9	1300	57.6	3.44	45.8	111.0	4.90	9.0	1500	59.0	3.31	47.7	106.4	5.22	8.3	1300	50.3	32.9	0.65	2.36	58.3	21.3	3.8	1500	52.1	37.0	0.71	2.47	60.5	21.1	4.2
80	6.0	0.9	2.1	1300	57.1	3.37	45.6	110.7	4.97	9.6	1500	58.6	3.23	47.5	106.2	5.31	8.8	1300	47.0	31.9	0.68	2.87	56.8	16.4	5.5	1500	48.6	35.8	0.74	3.00	58.8	16.2	5.8
	9.0	1.9	4.5	1300	60.1	3.50	48.1	112.8	5.03	9.8	1500	61.7	3.35	50.3	108.1	5.40	9.1	1300	47.8	32.2	0.67	2.72	57.1	17.6	5.1	1500	49.4	36.2	0.73	2.84	59.1	17.4	5.5
	12.0	3.3	7.6	1300	61.8	3.55	49.7	114.0	5.10	10.1	1500	63.5	3.39	51.9	109.2	5.49	9.4	1300	48.3	32.2	0.67	2.64	57.3	18.3	4.8	1500	49.9	36.2	0.72	2.75	59.3	18.1	5.3
90	6.0	0.9	2.1	1300	60.7	3.45	48.9	113.2	5.15	10.7	1500	62.4	3.29	51.2	108.5	5.56	9.9	1300	43.8	30.4	0.69	3.21	54.8	13.7	6.9	1500	45.2	34.1	0.76	3.34	56.6	13.5	7.3
	9.0	1.9	4.3	1300	64.1	3.61	51.7	115.6	5.20	11.1	1500	66.0	3.43	54.3	110.7	5.64	10.2	1300	44.7	30.7	0.69	3.03	55.1	14.8	6.4	1500	46.1	34.5	0.75	3.16	56.9	14.6	7.0
	12.0	3.2	7.4	1300	66.1	3.67	53.5	117.0	5.27	11.4	1500	68.1	3.48	56.2	112.0	5.73	10.6	1300	45.2	30.7	0.68	2.94	55.2	15.4	6.0	1500	46.6	34.5	0.74	3.06	57.0	15.2	6.6
100	6.0	0.9	2.0	Operation not recommended							Operation not recommended																						
	9.0	1.8	4.2	Operation not recommended							Operation not recommended																						
	12.0	3.1	7.1	Operation not recommended							Operation not recommended																						
110	6.0	0.8	1.9	Operation not recommended							Operation not recommended																						
	9.0	1.7	4.0	Operation not recommended							Operation not recommended																						
	12.0	3.0	6.8	Operation not recommended							Operation not recommended																						
120	6.0	0.8	1.8	Operation not recommended							Operation not recommended																						
	9.0	1.7	3.8	Operation not recommended							Operation not recommended																						
	12.0	2.8	6.6	Operation not recommended							Operation not recommended																						

GSZ060 - Performance Data

2000 CFM Rated Airflow

EWT °F	Flow gpm	WPD		HEATING - EAT 70°F							COOLING - EAT 80/67 °F														
		PSI	FT	Airflow cfm	HC kBtuh	Power kW	HE kBtuh	LAT °F	COP	HWC kBtuh	Airflow cfm	TC kBtuh	SC kBtuh	S/T Ratio	Power kW	HR kBtuh	EER	HWC kBtuh							
20	9.0	2.5	5.7	Operation not recommended							Operation not recommended														
	12.0	4.0	9.2	Operation not recommended							Operation not recommended														
	15.0	5.9	13.5	1500	36.3	3.63	23.9	92.4	2.93	6.2	2000	37.0	3.69	24.4	87.1	2.93	5.7								
30	9.0	2.4	5.5	Operation not recommended							Operation not recommended														
	12.0	3.9	8.9	1500	40.9	3.63	28.5	95.2	3.30	6.7	2000	41.7	3.70	29.1	89.3	3.30	6.1	1500	62.7	41.1	0.66	2.09	69.8	30.0	-
	15.0	5.7	13.1	1500	42.1	3.72	29.4	96.0	3.31	6.9	2000	43.0	3.79	30.0	89.9	3.32	6.2	1500	63.4	41.2	0.65	2.09	70.5	30.3	-
40	9.0	2.3	5.3	Operation not recommended							Operation not recommended														
	12.0	3.7	8.7	1500	53.8	3.80	37.1	100.9	3.86	7.3	2000	51.3	3.88	38.0	93.7	3.87	6.7	1500	62.5	41.6	0.66	2.32	70.4	26.9	-
	15.0	5.5	12.7	1500	51.5	3.89	38.2	101.8	3.88	7.6	2000	52.5	3.95	39.0	94.3	3.89	6.9	1500	63.2	41.7	0.66	2.32	71.1	27.3	-
50	9.0	2.2	5.2	1500	53.8	3.94	40.4	103.2	4.00	7.9	2000	54.4	3.99	40.8	95.2	4.00	7.3	1500	62.7	42.4	0.68	2.72	72.0	23.0	3.3
	12.0	3.6	8.4	1500	54.4	3.93	41.0	103.6	4.05	8.2	2000	55.8	4.03	42.1	95.8	4.06	7.5	1500	62.9	44.0	0.70	3.05	73.3	20.7	3.5
	15.0	5.3	12.3	1500	55.8	4.01	42.1	104.4	4.07	8.4	2000	56.8	4.07	42.9	96.3	4.09	7.7	1500	62.9	44.5	0.71	2.99	73.1	21.1	3.1
60	9.0	2.2	5.0	1500	61.8	4.08	47.9	108.2	4.44	8.9	2000	62.8	4.11	48.8	99.1	4.48	8.2	1500	62.9	42.5	0.68	2.63	71.8	23.9	3.1
	12.0	3.5	8.1	1500	63.3	4.10	49.3	109.1	4.53	9.2	2000	64.2	4.15	50.0	99.7	4.53	8.5	1500	63.5	42.7	0.67	2.61	72.4	24.3	2.9
	15.0	5.2	11.9	1500	64.7	4.17	50.5	109.9	4.55	9.5	2000	66.0	4.22	51.6	100.6	4.59	8.7	1500	63.6	44.5	0.70	2.85	73.3	22.3	3.2
70	9.0	2.1	4.9	1500	65.1	4.24	50.7	110.2	4.50	10.0	2000	66.5	4.26	52.0	100.8	4.57	9.3	1500	59.5	40.5	0.68	2.95	69.6	20.2	4.0
	12.0	3.4	7.9	1500	67.4	4.28	52.8	111.6	4.61	10.3	2000	67.8	4.30	53.1	101.4	4.61	9.5	1500	60.9	43.0	0.71	3.23	71.9	18.9	4.3
	15.0	5.0	11.6	1500	68.7	4.35	53.9	112.4	4.63	10.6	2000	70.3	4.39	55.3	102.5	4.69	9.8	1500	59.7	40.7	0.68	2.84	69.4	21.0	3.8
80	9.0	2.0	4.7	1500	72.6	4.34	57.7	114.8	4.89	11.3	2000	73.9	4.35	59.0	104.2	4.98	10.4	1500	61.2	43.2	0.71	3.14	71.9	19.5	4.1
	12.0	3.3	7.6	1500	75.8	4.42	60.7	116.8	5.03	11.6	2000	76.5	4.37	61.6	105.4	5.12	10.7	1500	60.3	40.9	0.68	2.81	69.9	21.5	3.5
	15.0	4.8	11.2	1500	77.0	4.47	61.8	117.6	5.05	12.0	2000	78.6	4.51	63.2	106.4	5.11	11.0	1500	61.5	43.4	0.71	3.02	71.8	20.4	3.9
90	9.0	2.0	4.5	1500	74.6	4.50	59.3	116.1	4.85	12.7	2000	75.8	4.50	60.5	105.1	4.94	11.7	1500	57.3	39.6	0.69	3.31	68.5	17.3	5.1
	12.0	3.2	7.3	1500	78.6	4.61	62.9	118.5	5.00	13.0	2000	79.5	4.50	64.2	106.8	5.18	12.1	1500	57.5	39.9	0.69	3.18	68.4	18.1	4.7
	15.0	4.7	10.8	1500	79.6	4.66	63.8	119.2	5.01	13.4	2000	81.0	4.69	65.1	107.5	5.07	12.5	1500	60.4	43.0	0.71	3.43	72.1	17.6	5.1
100	9.0	1.9	4.4	Operation not recommended							Operation not recommended														
	12.0	3.1	7.1	Operation not recommended							Operation not recommended														
	15.0	4.5	10.4	Operation not recommended							Operation not recommended														
110	9.0	1.8	4.2	Operation not recommended							Operation not recommended														
	12.0	2.9	6.8	Operation not recommended							Operation not recommended														
	15.0	4.3	10.0	Operation not recommended							Operation not recommended														
120	9.0	1.7	4.0	Operation not recommended							Operation not recommended														
	12.0	2.8	6.5	Operation not recommended							Operation not recommended														
	15.0	4.2	9.6	Operation not recommended							Operation not recommended														

GSZ070 - Performance Data

2200 CFM Rated Airflow

EWT °F	Flow gpm	WPD		HEATING - EAT 70°F							COOLING - EAT 80/67 °F												
		PSI	FT	Airflow cfm	HC kBTuh	Power kW	HE kBTuh	LAT °F	COP	HWC kBTuh	Airflow cfm	TC kBTuh	SC kBTuh	S/T Ratio	Power kW	HR kBTuh	EER	HWC kBTuh					
20	12.0	3.0	7.0	Operation not recommended							Operation not recommended												
	15.0	4.4	10.2	Operation not recommended							Operation not recommended												
	18.0	6.0	13.9	1700	43.8	4.87	27.1	93.8	2.63	7.5	2200	44.8	4.97	27.9	88.9	2.64	6.8						
30	12.0	3.0	6.8	Operation not recommended							Operation not recommended												
	15.0	4.3	9.9	1700	50.5	4.98	33.5	97.5	2.97	7.9	1700	58.6	36.7	0.63	2.41	66.8	24.4	-					
	18.0	5.8	13.5	1700	50.7	5.00	33.6	97.6	2.97	8.2	1700	58.9	36.2	0.62	2.40	67.1	24.5	-					
40	12.0	2.9	6.6	Operation not recommended							Operation not recommended												
	15.0	4.1	9.6	1700	58.9	5.20	41.1	102.1	3.32	8.8	1700	61.8	38.9	0.63	2.64	70.8	23.4	-					
	18.0	5.7	13.1	1700	59.3	5.23	41.4	102.3	3.32	9.0	1700	62.3	38.8	0.62	2.63	71.2	23.7	-					
50	12.0	2.8	6.4	1700	64.9	5.36	46.6	105.4	3.55	9.5	1700	64.8	40.9	0.63	3.03	75.1	21.4	3.6					
	15.0	4.0	9.3	1700	66.2	5.41	47.8	106.1	3.59	9.8	1700	65.1	41.1	0.63	2.94	75.1	22.1	3.4					
	18.0	5.5	12.7	1700	66.8	5.45	48.2	106.4	3.59	10.1	1700	65.7	41.3	0.63	2.91	75.7	22.6	3.1					
60	12.0	2.7	6.2	1700	71.9	5.57	52.9	109.2	3.78	10.6	1700	62.3	39.6	0.64	3.33	73.6	18.7	4.4					
	15.0	3.9	9.0	1700	74.0	5.65	54.8	110.3	3.84	11.0	1700	62.6	39.7	0.63	3.24	73.6	19.3	4.1					
	18.0	5.3	12.3	1700	74.9	5.70	55.5	110.8	3.85	11.3	1700	63.3	40.2	0.64	3.19	74.2	19.8	3.8					
70	12.0	2.6	6.0	1700	79.3	5.80	59.5	113.2	4.00	12.0	1700	62.1	40.2	0.65	3.72	74.7	16.7	5.5					
	15.0	3.8	8.7	1700	82.2	5.91	62.1	114.8	4.08	12.3	1700	62.3	40.2	0.65	3.61	74.6	17.3	5.1					
	18.0	5.1	11.9	1700	83.4	5.96	63.0	115.4	4.10	12.7	1700	63.3	41.1	0.65	3.55	75.3	17.8	4.8					
80	12.0	2.5	5.8	1700	84.7	6.03	64.2	116.2	4.12	13.4	1700	59.5	38.4	0.65	4.15	73.7	14.4	6.9					
	15.0	3.6	8.4	1700	88.6	6.16	67.6	118.3	4.21	13.9	1700	59.7	38.4	0.64	4.03	73.5	14.8	6.5					
	18.0	5.0	11.5	1700	90.0	6.22	68.8	119.0	4.24	14.3	1700	60.8	39.6	0.65	3.95	74.2	15.4	6.0					
90	12.0	2.4	5.6	1700	90.5	6.26	69.2	119.3	4.23	15.1	1700	54.7	35.7	0.65	4.60	70.4	11.9	8.7					
	15.0	3.5	8.1	1700	93.2	6.06	72.5	109.2	4.51	14.0	1700	56.9	40.9	0.72	5.01	73.9	11.4	9.2					
	18.0	4.8	11.1	1700	95.3	6.43	73.4	121.9	4.35	15.6	1700	54.8	35.6	0.65	4.48	70.1	12.2	8.1					
100	12.0	2.3	5.4	Operation not recommended							Operation not recommended												
	15.0	3.4	7.8	Operation not recommended							Operation not recommended												
	18.0	4.6	10.7	1700	100.1	6.26	78.8	112.1	4.69	14.9	1700	53.2	35.2	0.66	5.05	70.4	10.5	10.1					
110	12.0	2.2	5.2	Operation not recommended							Operation not recommended												
	15.0	3.3	7.5	Operation not recommended							Operation not recommended												
	18.0	4.4	10.2	1700	47.2	31.2	0.66	5.62	66.4	8.4	12.4	1700	48.4	33.1	0.68	5.45	66.9	8.9	11.5				
120	12.0	2.2	5.0	Operation not recommended							Operation not recommended												
	15.0	3.1	7.2	Operation not recommended							Operation not recommended												
	18.0	4.3	9.8	1700	44.8	31.6	0.71	6.31	66.3	7.1	14.9	1700	46.0	33.8	0.73	6.10	66.8	7.5	13.9				

GTZ026 High Speed - Performance Data

900 CFM Rated Airflow

EWT °F	Flow gpm	WPD		HEATING - EAT 70°F								COOLING - EAT 80/67 °F													
		PSI	FT	Airflow cfm	HC kBtuh	Power kW	HE kBtuh	LAT °F	COP	HWC kBtuh	Airflow cfm	TC kBtuh	SC kBtuh	S/T Ratio	Power kW	HR kBtuh	EER	HWC kBtuh							
20	4.0	1.4	3.2	Operation not recommended								Operation not recommended													
	6.0	2.9	6.6	Operation not recommended								Operation not recommended													
	8.0	4.8	11.1	700	15.4	1.38	10.7	90.3	3.25	2.0	900	15.6	1.40	10.8	86.0	3.27	1.8								
30	4.0	1.4	3.2	Operation not recommended								Operation not recommended													
	6.0	2.8	6.4	700	17.6	1.42	12.8	93.3	3.63	2.1	900	18.0	1.44	13.1	88.5	3.67	2.0	700	25.6	16.9	0.66	0.93	28.7	27.5	-
	8.0	4.7	10.8	700	18.0	1.44	13.1	93.8	3.67	2.2	900	18.2	1.45	13.3	88.8	3.69	2.0	700	25.7	16.9	0.66	0.90	28.8	28.5	-
	900	26.3	18.4	0.70	0.94	29.5	27.9	-																	
40	4.0	1.3	3.1	Operation not recommended								Operation not recommended													
	6.0	2.7	6.2	700	20.5	1.48	15.5	97.1	4.06	2.4	900	20.9	1.49	15.9	91.5	4.12	2.2	700	25.9	17.3	0.67	1.01	29.4	25.7	-
	8.0	4.5	10.4	700	20.9	1.50	15.8	97.6	4.08	2.4	900	21.3	1.50	16.2	91.9	4.16	2.2	700	26.1	17.3	0.66	0.98	29.5	26.7	-
	900	26.7	18.9	0.71	1.02	30.2	26.1	-																	
50	4.0	1.3	3.0	700	22.1	1.52	17.0	99.3	4.27	2.6	900	22.6	1.52	17.4	93.2	4.36	2.4	700	25.7	17.5	0.68	1.18	29.8	21.9	1.2
	6.0	2.6	6.0	700	23.3	1.55	18.0	100.8	4.39	2.7	900	23.7	1.55	18.4	94.4	4.48	2.4	700	26.0	17.7	0.68	1.12	29.8	23.3	1.1
	8.0	4.4	10.1	700	23.6	1.57	18.2	101.2	4.40	2.7	900	24.2	1.56	18.8	94.8	4.53	2.5	700	26.3	17.7	0.67	1.08	30.0	24.3	1.0
	900	26.8	19.3	0.72	1.13	30.7	23.8	1.1																	
60	4.0	1.2	2.9	700	24.9	1.60	19.5	103.0	4.57	2.9	900	25.5	1.58	20.1	96.2	4.72	2.7	700	25.4	17.4	0.68	1.28	29.8	19.9	1.4
	6.0	2.5	5.8	700	26.1	1.63	20.5	104.5	4.69	3.0	900	26.7	1.62	21.2	97.5	4.84	2.7	700	25.7	17.6	0.68	1.21	29.8	21.2	1.3
	8.0	4.2	9.8	700	26.5	1.65	20.9	105.1	4.70	3.1	900	27.2	1.63	21.6	98.0	4.89	2.8	700	26.0	17.6	0.68	1.18	30.0	22.1	1.2
	900	26.5	19.2	0.72	1.22	30.6	21.7	1.4																	
70	4.0	1.2	2.8	700	27.8	1.68	22.1	106.8	4.84	3.3	900	28.5	1.65	22.8	99.3	5.05	3.0	700	25.1	17.4	0.69	1.42	30.0	17.7	1.8
	6.0	2.4	5.6	700	29.0	1.72	23.2	108.4	4.95	3.4	900	29.9	1.69	24.1	100.8	5.17	3.1	700	25.3	17.5	0.69	1.34	29.9	18.9	1.6
	8.0	4.1	9.5	700	29.6	1.74	23.6	109.1	4.99	3.5	900	30.3	1.71	24.5	101.2	5.22	3.2	700	25.6	17.5	0.68	1.31	30.1	19.6	1.5
	900	26.1	19.1	0.73	1.35	30.7	19.3	1.7																	
80	4.0	1.2	2.7	700	30.3	1.78	24.2	110.1	4.98	3.6	900	31.2	1.74	25.3	102.1	5.25	3.4	700	24.1	17.0	0.71	1.57	29.5	15.3	2.2
	6.0	2.4	5.4	700	31.7	1.82	25.4	111.9	5.08	3.8	900	32.7	1.78	26.6	103.6	5.38	3.5	700	24.3	17.2	0.71	1.49	29.4	16.3	2.0
	8.0	4.0	9.2	700	32.2	1.85	25.9	112.6	5.11	3.9	900	33.2	1.80	27.1	104.2	5.42	3.6	700	24.6	17.2	0.70	1.44	29.6	17.1	1.9
	900	25.1	18.7	0.75	1.49	30.2	16.8	2.1																	
90	4.0	1.1	2.6	700	33.0	1.89	26.5	113.6	5.10	4.1	900	34.1	1.84	27.8	105.0	5.44	3.8	700	22.9	16.5	0.72	1.74	28.8	13.2	2.7
	6.0	2.3	5.2	700	34.4	1.94	27.8	115.5	5.20	4.2	900	35.6	1.87	29.2	106.6	5.58	3.9	700	23.4	17.9	0.76	1.79	29.5	13.0	2.9
	8.0	3.8	8.8	700	34.9	1.96	28.3	116.2	5.22	4.3	900	36.3	1.89	29.8	107.3	5.61	4.0	700	23.1	16.7	0.72	1.65	28.7	14.0	2.5
	900	23.4	16.7	0.71	1.59	28.8	14.7	2.4	700	23.6	18.1	0.77	1.69	29.4	13.9	2.8	700	23.4	16.7	0.71	1.59	28.8	14.7	2.4	
	900	23.8	18.1	0.76	1.65	29.4	14.4	2.6																	
100	4.0	1.1	2.5	Operation not recommended								Operation not recommended													
	6.0	2.2	5.1	Operation not recommended								Operation not recommended													
	8.0	3.7	8.5	700	21.9	1.62	17.4	93.2	4.36	2.4	900	22.4	1.62	17.6	93.2	4.36	2.4	700	22.2	16.2	0.73	1.79	28.3	12.4	2.9
	900	22.6	17.6	0.78	1.84	28.9	12.2	3.2																	
110	4.0	1.0	2.4	Operation not recommended								Operation not recommended													
	6.0	2.1	4.9	Operation not recommended								Operation not recommended													
	8.0	3.5	8.2	700	20.1	1.52	15.2	91.9	4.16	2.2	900	20.5	1.52	15.4	91.9	4.16	2.2	700	20.3	15.2	0.75	1.98	27.1	10.3	3.6
	900	20.7	16.6	0.80	2.04	27.7	10.2	3.9																	
120	4.0	1.0	2.3	Operation not recommended								Operation not recommended													
	6.0	2.0	4.7	Operation not recommended								Operation not recommended													
	8.0	3.4	7.9	700	18.6	1.46	13.1	88.5	3.67	2.0	900	18.9	1.46	13.3	88.5	3.67	2.0	700	18.7	14.6	0.78	2.21	26.3	8.5	4.3
	900	19.1	15.9	0.83	2.28	26.9	8.4	4.8																	

GTZ026 Low Speed - Performance Data

700 CFM Rated Airflow

EWT °F	Flow gpm	WPD		HEATING - EAT 70°F							COOLING - EAT 80/67 °F																														
		PSI	FT	Airflow cfm	HC kBtuh	Power kW	HE kBtuh	LAT °F	COP	HWC kBtuh	Airflow cfm	TC kBtuh	SC kBtuh	S/T Ratio	Power kW	HR kBtuh	EER	HWC kBtuh																							
20	3.0	0.8	1.9	Operation not recommended							Operation not recommended																														
	5.0	2.0	4.7	Operation not recommended							Operation not recommended																														
	7.0	3.7	8.7	500	11.0	1.08	7.3	90.4	2.98	1.7	700	11.2	1.09	7.4	84.8	2.99	1.5	Operation not recommended																							
30	3.0	0.8	1.8	Operation not recommended							Operation not recommended																														
	5.0	2.0	4.5	500	12.7	1.10	8.9	93.5	3.38	1.6	500	18.9	12.6	0.66	0.56	20.8	33.9	-	700	12.9	1.11	9.2	87.1	3.42	1.5	700	19.2	13.7	0.71	0.59	21.2	32.7	-								
	7.0	3.6	8.4	500	12.9	1.11	9.2	93.9	3.42	1.7	500	19.0	12.6	0.66	0.54	20.9	35.1	-	700	13.1	1.12	9.3	87.3	3.44	1.5	700	19.5	13.7	0.70	0.57	21.4	34.3	-								
40	3.0	0.8	1.8	Operation not recommended							Operation not recommended																														
	5.0	1.9	4.4	500	14.9	1.11	11.2	97.7	3.95	1.7	500	21.8	14.3	0.65	0.68	24.1	32.0	-	700	15.2	1.11	11.4	90.2	4.01	1.5	700	22.2	15.6	0.70	0.71	24.7	31.1	-								
	7.0	3.5	8.2	500	15.2	1.12	11.4	98.1	3.97	1.7	500	22.0	14.3	0.65	0.66	24.3	33.3	-	700	15.5	1.12	11.7	90.5	4.05	1.6	700	22.5	15.6	0.69	0.69	24.8	32.5	-								
50	3.0	0.7	1.7	500	16.2	1.10	12.4	99.9	4.29	1.7	500	23.2	14.6	0.63	0.87	26.2	26.7	1.1	700	16.5	1.10	12.7	91.8	4.37	1.6	700	23.7	15.9	0.67	0.90	26.8	26.2	1.1								
	5.0	1.8	4.3	500	17.0	1.13	13.1	101.4	4.41	1.8	500	23.4	14.8	0.63	0.83	26.3	28.4	1.0	700	17.3	1.13	13.5	92.9	4.49	1.7	700	23.9	16.1	0.67	0.86	26.9	27.8	1.1								
	7.0	3.4	7.9	500	17.2	1.14	13.3	101.9	4.41	1.9	500	23.7	14.8	0.62	0.80	26.4	29.6	0.9	700	17.6	1.14	13.8	93.3	4.55	1.7	700	24.2	16.1	0.67	0.83	27.0	29.0	1.0								
60	3.0	0.7	1.7	500	18.3	1.12	14.5	103.9	4.77	1.9	500	21.5	13.9	0.65	0.89	24.6	24.2	1.3	700	18.7	1.11	14.9	94.7	4.93	1.8	700	22.0	15.2	0.69	0.92	25.1	23.8	1.4								
	5.0	1.8	4.1	500	19.1	1.15	15.2	105.4	4.89	2.0	500	21.7	14.1	0.65	0.84	24.6	25.8	1.2	700	19.6	1.14	15.7	96.0	5.05	1.8	700	22.2	15.3	0.69	0.88	25.2	25.3	1.3								
	7.0	3.3	7.6	500	19.5	1.16	15.5	106.0	4.91	2.0	500	22.0	14.1	0.64	0.82	24.8	26.8	1.1	700	19.9	1.15	16.0	96.4	5.10	1.9	700	22.4	15.3	0.68	0.85	25.3	26.3	1.2								
70	3.0	0.7	1.6	500	20.5	1.14	16.6	108.0	5.28	2.1	500	22.2	14.4	0.65	1.10	26.0	20.2	1.6	700	21.0	1.11	17.2	97.8	5.52	2.0	700	22.7	15.6	0.69	1.15	26.6	19.8	1.7								
	5.0	1.7	4.0	500	21.4	1.16	17.4	109.6	5.41	2.2	500	22.4	14.5	0.65	1.04	26.0	21.5	1.5	700	22.1	1.14	18.2	99.2	5.65	2.0	700	22.9	15.8	0.69	1.08	26.6	21.1	1.6								
	7.0	3.2	7.4	500	21.8	1.17	17.8	110.4	5.44	2.2	500	22.7	14.5	0.64	1.02	26.1	22.3	1.4	700	22.4	1.15	18.5	99.6	5.69	2.1	700	23.1	15.8	0.68	1.05	26.7	22.0	1.5								
80	3.0	0.7	1.6	500	22.3	1.17	18.3	111.2	5.59	2.4	500	20.4	13.5	0.66	1.15	24.3	17.7	2.0	700	22.9	1.14	19.0	100.3	5.90	2.2	700	20.8	14.7	0.70	1.19	24.8	17.5	2.1								
	5.0	1.7	3.9	500	23.2	1.19	19.2	113.0	5.70	2.4	500	20.5	13.6	0.66	1.09	24.2	18.9	1.9	700	24.0	1.16	20.0	101.7	6.04	2.3	700	21.0	14.8	0.71	1.12	24.8	18.7	2.0								
	7.0	3.1	7.1	500	23.6	1.21	19.5	113.8	5.73	2.5	500	20.8	13.6	0.66	1.06	24.4	19.7	1.7	700	24.4	1.18	20.4	102.3	6.08	2.3	700	21.2	14.8	0.70	1.09	24.9	19.4	1.9								
90	3.0	0.7	1.5	500	24.1	1.19	20.1	114.7	5.92	2.7	500	19.7	13.7	0.70	1.42	24.5	13.8	2.5	700	24.9	1.16	21.0	103.0	6.31	2.5	700	20.1	14.9	0.74	1.47	25.1	13.7	2.6								
	5.0	1.6	3.7	500	25.2	1.22	21.0	116.6	6.03	2.8	500	19.8	13.9	0.70	1.35	24.4	14.7	2.3	700	26.1	1.18	22.0	104.5	6.47	2.6	700	20.3	15.1	0.74	1.39	25.0	14.6	2.5								
	7.0	3.0	6.9	500	25.6	1.24	21.4	117.4	6.06	2.8	500	20.1	13.9	0.69	1.30	24.6	15.4	2.1	700	26.5	1.19	22.5	105.1	6.51	2.6	700	20.5	15.1	0.74	1.35	25.1	15.2	2.4								
100	3.0	0.6	1.5	Operation not recommended							Operation not recommended																														
	5.0	1.6	3.6	Operation not recommended							Operation not recommended																														
	7.0	2.9	6.6	Operation not recommended							500	18.2	13.0	0.71	1.42	23.0	12.9	2.8	500	18.6	14.1	0.76	1.46	23.6	12.8	3.1	700	18.4	13.0	0.70	1.37	23.1	13.4	2.6	700	18.8	14.1	0.75	1.42	23.6	13.3
110	3.0	0.6	1.4	Operation not recommended							Operation not recommended																														
	5.0	1.5	3.4	Operation not recommended							Operation not recommended																														
	7.0	2.8	6.4	Operation not recommended							500	17.0	13.0	0.76	1.72	22.9	9.9	3.5	500	17.4	14.1	0.81	1.77	23.4	9.8	3.8	500	17.2	13.0	0.75	1.67	22.9	10.3	3.2	500	17.6	14.1	0.80	1.72	23.4	10.2
120	3.0	0.6	1.3	Operation not recommended							Operation not recommended																														
	5.0	1.4	3.3	Operation not recommended							Operation not recommended																														
	7.0	2.7	6.1	Operation not recommended							500	15.8	12.6	0.79	1.95	22.5	8.1	4.2	500	16.1	13.6	0.85	2.00	22.9	8.1	4.5	500	16.0	12.6	0.79	1.89	22.4	8.5	3.9	500	16.3	13.6	0.84	1.95	22.9	8.4

GTZ038 High Speed - Performance Data

1250 CFM Rated Airflow

EWT °F	Flow gpm	WPD		HEATING - EAT 70°F							COOLING - EAT 80/67 °F												
		PSI	FT	Airflow cfm	HC kBtuh	Power kW	HE kBtuh	LAT °F	COP	HWC kBtuh	Airflow cfm	TC kBtuh	SC kBtuh	S/T Ratio	Power kW	HR kBtuh	EER	HWC kBtuh					
20	5.0	1.3	3.0	Operation not recommended							Operation not recommended												
	7.0	2.3	5.2	Operation not recommended							Operation not recommended												
	9.0	3.5	8.1	1050	21.9	2.12	14.7	89.3	3.03	2.8	1250	22.6	2.18	15.2	86.7	3.04	2.5						
30	5.0	1.2	2.9	Operation not recommended							Operation not recommended												
	7.0	2.2	5.1	1050	25.2	2.16	17.9	92.2	3.43	3.0	1050	33.9	20.1	0.59	1.45	38.9	23.4	-					
				1250	25.9	2.22	18.4	89.2	3.42	2.7	1250	35.9	22.4	0.63	1.54	41.1	23.3	-					
	9.0	3.4	7.9	1050	25.6	2.18	18.2	92.6	3.45	3.1	1050	34.2	22.2	0.65	1.41	39.0	24.3	-					
			1250	26.5	2.24	18.8	89.6	3.45	2.8	1250	36.2	24.6	0.68	1.50	41.3	24.1	-						
40	5.0	1.2	2.8	Operation not recommended							Operation not recommended												
	7.0	2.1	4.9	1050	29.4	2.28	21.7	96.0	3.78	3.3	1050	35.3	21.6	0.61	1.60	40.7	22.0	-					
				1250	30.3	2.33	22.4	92.5	3.81	3.0	1250	37.2	24.0	0.65	1.69	42.9	22.0	-					
	9.0	3.3	7.6	1050	30.0	2.31	22.2	96.5	3.81	3.4	1050	35.5	23.4	0.66	1.56	40.9	22.8	-					
			1250	31.0	2.36	23.0	92.9	3.85	3.1	1250	37.6	26.0	0.69	1.65	43.2	22.7	-						
50	5.0	1.2	2.7	1050	31.9	2.34	23.9	98.1	3.99	3.6	1050	35.5	22.5	0.63	1.90	41.9	18.6	1.7					
				1250	32.9	2.37	24.8	94.3	4.05	3.3	1250	37.3	25.0	0.67	2.00	44.1	18.6	1.8					
	7.0	2.1	4.8	1050	33.1	2.40	24.9	99.2	4.04	3.7	1050	36.2	22.7	0.63	1.79	42.3	20.2	1.6					
				1250	34.1	2.43	25.9	95.3	4.12	3.4	1250	38.1	25.2	0.66	1.88	44.5	20.2	1.7					
	9.0	3.2	7.4	1050	33.8	2.42	25.6	99.8	4.10	3.8	1050	36.6	24.3	0.66	1.75	42.5	20.9	1.5					
				1250	34.9	2.45	26.5	95.8	4.17	3.5	1250	38.5	27.0	0.70	1.84	44.8	21.0	1.7					
60	5.0	1.1	2.6	1050	35.2	2.46	26.8	101.0	4.19	4.1	1050	35.1	23.0	0.66	2.03	42.0	17.3	2.1					
				1250	36.3	2.47	27.9	96.9	4.30	3.7	1250	36.8	25.6	0.70	2.12	44.0	17.4	2.2					
	7.0	2.0	4.6	1050	36.8	2.53	28.2	102.4	4.26	4.2	1050	35.9	23.3	0.65	1.93	42.5	18.6	1.9					
				1250	38.0	2.54	29.3	98.1	4.37	3.8	1250	37.6	25.8	0.69	2.01	44.5	18.8	2.1					
	9.0	3.1	7.2	1050	37.7	2.55	29.0	103.2	4.32	4.3	1050	36.3	24.5	0.68	1.88	42.7	19.3	1.8					
				1250	38.9	2.56	30.2	98.8	4.44	3.9	1250	38.1	27.2	0.71	1.96	44.7	19.4	2.0					
70	5.0	1.1	2.5	1050	38.5	2.59	29.7	104.0	4.36	4.5	1050	35.0	23.8	0.68	2.22	42.6	15.8	2.6					
				1250	39.9	2.59	31.0	99.5	4.51	4.2	1250	36.6	26.5	0.72	2.31	44.5	15.9	2.7					
	7.0	1.9	4.5	1050	40.5	2.68	31.4	105.7	4.44	4.7	1050	36.0	24.1	0.67	2.13	43.2	16.9	2.4					
				1250	41.8	2.68	32.7	101.0	4.58	4.3	1250	37.5	26.7	0.71	2.20	45.0	17.0	2.6					
	9.0	3.0	6.9	1050	41.6	2.71	32.3	106.6	4.50	4.8	1050	36.3	25.0	0.69	2.08	43.4	17.5	2.2					
				1250	43.0	2.70	33.8	101.8	4.67	4.4	1250	38.0	27.7	0.73	2.16	45.3	17.6	2.5					
80	5.0	1.1	2.5	1050	41.0	2.70	31.8	106.1	4.46	5.1	1050	33.8	23.5	0.69	2.42	42.0	14.0	3.2					
				1250	42.4	2.67	33.3	101.4	4.65	4.7	1250	35.2	26.1	0.74	2.49	43.7	14.1	3.4					
	7.0	1.9	4.3	1050	43.4	2.80	33.8	108.2	4.53	5.3	1050	34.7	23.7	0.68	2.33	42.7	14.9	3.0					
				1250	44.8	2.78	35.4	103.2	4.73	4.9	1250	36.1	26.3	0.73	2.40	44.3	15.0	3.2					
	9.0	2.9	6.7	1050	44.6	2.84	34.9	109.3	4.60	5.4	1050	35.1	24.3	0.69	2.28	42.9	15.4	2.8					
				1250	46.1	2.80	36.6	104.2	4.83	5.0	1250	36.6	27.0	0.74	2.35	44.6	15.5	3.1					
90	5.0	1.0	2.4	1050	43.5	2.82	33.9	108.4	4.52	5.7	1050	31.9	22.8	0.71	2.61	40.8	12.2	4.0					
				1250	45.1	2.78	35.6	103.4	4.76	5.3	1250	33.1	25.4	0.77	2.67	42.2	12.4	4.2					
	7.0	1.8	4.2	1050	46.2	2.94	36.2	110.8	4.60	5.9	1050	32.9	23.1	0.70	2.54	41.5	13.0	3.7					
				1250	47.9	2.89	38.0	105.5	4.85	5.4	1250	34.1	25.7	0.75	2.60	43.0	13.1	4.0					
	9.0	2.8	6.5	1050	47.7	2.99	37.5	112.1	4.68	6.1	1050	33.3	23.3	0.70	2.49	41.8	13.3	3.4					
				1250	49.3	2.91	39.4	106.5	4.96	5.6	1250	34.5	25.8	0.75	2.55	43.2	13.5	3.8					
100	5.0	1.0	2.3	Operation not recommended							Operation not recommended												
	7.0	1.7	4.0	Operation not recommended							1050	31.7	22.9	0.72	2.83	41.3	11.2	4.6					
				Operation not recommended							1250	32.7	25.4	0.78	2.87	42.5	11.4	5.0					
	9.0	2.7	6.2	Operation not recommended							1050	32.0	22.9	0.71	2.78	41.5	11.5	4.2					
				Operation not recommended							1250	33.1	25.3	0.76	2.82	42.7	11.7	4.7					
110	5.0	1.0	2.2	Operation not recommended							Operation not recommended												
	7.0	1.7	3.9	Operation not recommended							1050	29.0	21.5	0.74	3.09	39.5	9.4	5.6					
				Operation not recommended							1250	29.8	23.9	0.80	3.11	40.4	9.6	6.0					
	9.0	2.6	6.0	Operation not recommended							1050	29.3	21.2	0.73	3.03	39.6	9.7	5.2					
				Operation not recommended							1250	30.1	23.4	0.78	3.07	40.5	9.8	5.8					
120	5.0	0.9	2.1	Operation not recommended							Operation not recommended												
	7.0	1.6	3.7	Operation not recommended							1050	27.2	21.1	0.77	3.45	39.0	7.9	6.7					
				Operation not recommended							1250	27.9	23.5	0.84	3.45	39.6	8.1	7.3					
	9.0	2.5	5.8	Operation not recommended							1050	27.5	20.5	0.75	3.39	39.1	8.1	6.2					
				Operation not recommended							1250	28.1	22.6	0.81	3.40	39.7	8.3	6.9					

GTZ038 Low Speed - Performance Data

1050 CFM Rated Airflow

EWT °F	Flow gpm	WPD		HEATING - EAT 70°F							COOLING - EAT 80/67 °F															
		PSI	FT	Airflow cfm	HC kBTuh	Power kW	HE kBTuh	LAT °F	COP	HWC kBTuh	Airflow cfm	TC kBTuh	SC kBTuh	S/T Ratio	Power kW	HR kBTuh	EER	HWC kBTuh								
20	4.0	0.9	2.1	Operation not recommended							Operation not recommended															
	6.0	1.7	4.0	Operation not recommended							Operation not recommended															
	8.0	2.9	6.7	900	15.3	1.47	10.3	85.8	3.05	2.4	1050	16.0	1.51	10.8	84.1	3.09	2.2									
30	4.0	0.9	2.0	Operation not recommended							Operation not recommended															
	6.0	1.7	3.9	900	17.0	1.46	12.1	87.5	3.42	2.4	1050	17.7	1.50	12.6	85.6	3.47	2.2	900	26.1	16.6	0.63	0.75	28.7	34.8	-	
	8.0	2.8	6.5	900	18.1	1.50	13.0	88.6	3.55	2.5	1050	18.9	1.53	13.6	86.6	3.60	2.2	900	26.6	17.0	0.64	0.74	29.1	35.7	-	
				1050	18.9	1.53	13.6	86.6	3.60	2.2	1050	27.3	18.8	0.69	0.76	29.9	36.0	-								
40	4.0	0.8	1.9	Operation not recommended							Operation not recommended															
	6.0	1.6	3.8	900	20.1	1.49	15.1	90.7	3.97	2.5	1050	20.8	1.51	15.7	88.4	4.03	2.3	900	21.8	14.3	0.65	0.68	24.1	32.0	-	
	8.0	2.7	6.3	900	21.2	1.52	16.0	91.8	4.08	2.5	1050	21.9	1.55	16.6	89.3	4.14	2.3	900	22.0	14.3	0.65	0.66	24.3	33.3	-	
				1050	21.9	1.55	16.6	89.3	4.14	2.3	1050	22.5	15.6	0.69	0.69	24.8	32.5	-								
50	4.0	0.8	1.9	900	22.2	1.51	17.0	92.8	4.29	2.6	1050	22.8	1.53	17.6	90.1	4.36	2.4	900	23.2	14.6	0.63	0.87	26.2	26.7	1.1	
	6.0	1.6	3.7	900	22.9	1.51	17.8	93.6	4.44	2.6	1050	23.6	1.53	18.4	90.8	4.52	2.4	900	23.4	14.8	0.63	0.83	26.3	28.4	1.0	
	8.0	2.6	6.1	900	24.0	1.55	18.7	94.7	4.54	2.7	1050	24.7	1.57	19.4	91.8	4.62	2.5	900	23.7	14.8	0.62	0.80	26.4	29.6	0.9	
				1050	24.0	1.57	19.4	91.8	4.62	2.5	1050	24.2	16.1	0.67	0.83	27.0	29.0	1.0								
60	4.0	0.8	1.8	900	25.0	1.54	19.7	95.7	4.75	2.8	1050	25.6	1.55	20.3	92.6	4.83	2.6	900	21.5	13.9	0.65	0.89	24.6	24.2	1.3	
	6.0	1.5	3.6	900	26.0	1.54	20.7	96.7	4.95	2.9	1050	26.6	1.55	21.3	93.5	5.03	2.6	900	21.7	14.1	0.65	0.84	24.6	25.8	1.2	
	8.0	2.5	5.9	900	26.9	1.57	21.5	97.7	5.01	3.0	1050	27.5	1.58	22.1	94.2	5.09	2.7	900	22.0	14.1	0.64	0.82	24.8	26.8	1.1	
				1050	27.5	1.58	22.1	94.2	5.09	2.7	1050	22.4	15.3	0.68	0.85	25.3	26.3	1.2								
70	4.0	0.8	1.8	900	27.7	1.57	22.4	98.5	5.18	3.1	1050	28.3	1.57	23.0	95.0	5.28	2.9	900	22.2	14.4	0.65	1.10	26.0	20.2	1.6	
	6.0	1.5	3.5	900	29.0	1.56	23.6	99.8	5.43	3.2	1050	29.5	1.56	24.2	96.0	5.54	2.9	900	22.4	14.5	0.65	1.04	26.0	21.5	1.5	
	8.0	2.5	5.7	900	29.7	1.60	24.3	100.6	5.46	3.3	1050	30.2	1.59	24.8	96.7	5.56	3.0	900	22.7	14.5	0.64	1.02	26.1	22.3	1.4	
				1050	30.2	1.59	24.8	96.7	5.56	3.0	1050	23.1	15.8	0.68	1.05	26.7	22.0	1.5								
80	4.0	0.7	1.7	900	30.4	1.60	24.9	101.2	5.57	3.5	1050	30.8	1.59	25.4	97.1	5.68	3.2	900	20.4	13.5	0.66	1.15	24.3	17.7	2.0	
	6.0	1.4	3.3	900	31.8	1.59	26.4	102.7	5.87	3.6	1050	32.2	1.58	26.8	98.4	5.99	3.3	900	20.5	13.6	0.66	1.09	24.2	18.9	1.9	
	8.0	2.4	5.5	900	32.3	1.62	26.8	103.2	5.84	3.7	1050	32.6	1.61	27.1	98.8	5.95	3.4	900	20.8	13.6	0.66	1.06	24.4	19.7	1.7	
				1050	32.6	1.61	27.1	98.8	5.95	3.4	1050	21.2	14.8	0.70	1.09	24.9	19.4	1.9								
90	4.0	0.7	1.6	900	32.9	1.62	27.4	103.9	5.94	3.9	1050	33.2	1.60	27.7	99.3	6.06	3.6	900	19.7	13.7	0.70	1.42	24.5	13.8	2.5	
	6.0	1.4	3.2	900	34.6	1.61	29.1	105.6	6.30	4.0	1050	34.9	1.59	29.4	100.7	6.43	3.7	900	20.1	14.9	0.74	1.47	25.1	13.7	2.6	
	8.0	2.3	5.3	900	34.8	1.64	29.2	105.8	6.21	4.2	1050	34.9	1.62	29.4	100.8	6.33	3.9	900	19.8	13.9	0.70	1.35	24.4	14.7	2.3	
				1050	34.9	1.62	29.4	100.8	6.33	3.9	1050	20.3	15.1	0.74	1.39	25.0	14.6	2.5	900	20.1	13.9	0.69	1.30	24.6	15.4	2.1
											1050	20.5	15.1	0.74	1.35	25.1	15.2	2.4								
100	4.0	0.7	1.6	Operation not recommended							Operation not recommended															
	6.0	1.3	3.1	Operation not recommended							Operation not recommended															
	8.0	2.2	5.1	900	18.1	1.50	13.0	88.6	3.55	2.5	1050	18.8	1.53	13.6	86.6	3.60	2.2	900	18.2	13.0	0.71	1.42	23.0	12.9	2.8	
				1050	18.8	1.53	13.6	86.6	3.60	2.2	1050	18.6	14.1	0.76	1.46	23.6	12.8	3.1	900	18.4	13.0	0.70	1.37	23.1	13.4	2.6
											1050	18.8	14.1	0.75	1.42	23.6	13.3	2.9								
110	4.0	0.7	1.5	Operation not recommended							Operation not recommended															
	6.0	1.3	3.0	Operation not recommended							Operation not recommended															
	8.0	2.1	4.9	900	17.0	1.46	12.1	87.5	3.42	2.4	1050	17.4	14.1	0.81	1.77	23.4	9.8	3.8								
				1050	17.4	14.1	0.81	1.77	23.4	9.8	3.8	900	17.2	13.0	0.75	1.67	22.9	10.3	3.2							
											1050	17.6	14.1	0.80	1.72	23.4	10.2	3.6								
120	4.0	0.6	1.5	Operation not recommended							Operation not recommended															
	6.0	1.2	2.9	Operation not recommended							Operation not recommended															
	8.0	2.0	4.7	900	15.8	1.47	10.3	85.8	3.05	2.4	1050	16.1	1.51	10.8	84.1	3.09	2.2	900	15.8	12.6	0.79	1.95	22.5	8.1	4.2	
				1050	16.1	1.51	10.8	84.1	3.09	2.2	1050	16.0	12.6	0.79	1.89	22.4	8.5	3.9								
											1050	16.3	13.6	0.84	1.95	22.9	8.4	4.3								

GTZ049 High Speed - Performance Data

1550 CFM Rated Airflow

EWT °F	Flow gpm	WPD		HEATING - EAT 70°F							COOLING - EAT 80/67 °F														
		PSI	FT	Airflow cfm	HC kBtuh	Power kW	HE kBtuh	LAT °F	COP	HWC kBtuh	Airflow cfm	TC kBtuh	SC kBtuh	S/T Ratio	Power kW	HR kBtuh	EER	HWC kBtuh							
20	6.0	1.3	3.0	Operation not recommended							Operation not recommended														
	9.0	2.5	5.7	Operation not recommended							Operation not recommended														
	12.0	4.0	9.2	1350	31.3	2.72	22.1	91.5	3.38	5.3	1550	32.4	2.80	22.8	89.3	3.38	4.8								
30	6.0	1.2	2.9	Operation not recommended							Operation not recommended														
	9.0	2.4	5.5	1350	35.8	2.85	26.1	94.5	3.68	5.6	1550	36.9	2.94	26.8	92.0	3.68	5.2	1350	47.5	29.3	0.62	1.89	54.0	25.1	-
	12.0	3.9	8.9	1350	36.3	2.88	26.5	94.9	3.70	5.8	1550	37.5	2.97	27.4	92.4	3.71	5.3	1350	50.4	32.6	0.65	2.02	57.3	25.0	-
40	6.0	1.2	2.8	Operation not recommended							Operation not recommended														
	9.0	2.3	5.3	1350	40.8	2.97	30.6	98.0	4.02	6.2	1550	42.0	3.04	31.6	95.1	4.04	5.7	1350	49.3	31.0	0.63	2.09	56.4	23.6	-
	12.0	3.7	8.7	1350	41.5	3.01	31.2	98.5	4.04	6.4	1550	42.9	3.07	32.4	95.6	4.09	5.8	1350	49.8	31.0	0.62	2.00	56.7	24.9	-
50	6.0	1.2	2.7	1350	43.6	3.08	33.1	99.9	4.15	6.7	1550	45.0	3.12	34.4	96.9	4.23	6.2	1350	49.9	31.8	0.64	2.50	58.4	20.0	3.0
	9.0	2.2	5.2	1350	45.3	3.14	34.6	101.1	4.23	6.9	1550	46.6	3.19	35.8	97.9	4.29	6.4	1350	50.5	32.2	0.64	2.34	58.4	21.6	2.8
	12.0	3.6	8.4	1350	46.2	3.18	35.4	101.7	4.27	7.2	1550	47.8	3.22	36.8	98.5	4.35	6.5	1350	51.0	32.3	0.63	2.25	58.7	22.7	2.6
60	6.0	1.1	2.6	1350	47.6	3.21	36.7	102.7	4.35	7.6	1550	49.1	3.22	38.1	99.3	4.47	7.0	1350	49.3	32.1	0.65	2.65	58.4	18.6	3.6
	9.0	2.2	5.0	1350	49.8	3.29	38.6	104.1	4.44	7.8	1550	51.3	3.30	40.0	100.6	4.55	7.2	1350	51.7	32.5	0.65	2.50	58.7	20.0	3.4
	12.0	3.5	8.1	1350	50.9	3.33	39.6	104.9	4.48	8.0	1550	52.6	3.34	41.2	101.4	4.62	7.4	1350	52.6	36.1	0.69	2.61	61.5	20.1	3.7
70	6.0	1.1	2.5	1350	51.5	3.32	40.2	105.4	4.55	8.5	1550	53.1	3.31	41.8	101.7	4.70	7.9	1350	49.0	32.7	0.67	2.90	58.9	16.9	4.6
	9.0	2.1	4.9	1350	54.1	3.42	42.4	107.1	4.63	8.8	1550	55.8	3.41	44.1	103.3	4.79	8.1	1350	51.2	33.1	0.66	2.76	59.5	18.2	4.3
	12.0	3.4	7.9	1350	55.5	3.47	43.7	108.1	4.69	9.0	1550	57.3	3.45	45.5	104.2	4.87	8.3	1350	52.3	36.7	0.70	2.86	62.1	18.3	4.6
80	6.0	1.1	2.5	1350	54.7	3.49	42.7	107.5	4.58	9.6	1550	56.4	3.45	44.7	103.7	4.79	8.8	1350	50.6	33.3	0.66	2.68	59.8	18.9	4.0
	9.0	2.0	4.7	1350	57.7	3.62	45.4	109.6	4.67	9.8	1550	59.6	3.58	47.4	105.6	4.88	9.1	1350	48.7	32.6	0.67	2.95	58.8	16.5	5.0
	12.0	3.3	7.6	1350	59.4	3.66	46.9	110.7	4.75	10.1	1550	61.3	3.62	49.0	106.6	4.97	9.4	1350	50.7	36.2	0.71	3.03	61.0	16.7	5.6
90	6.0	1.0	2.4	1350	57.7	3.66	45.2	109.6	4.62	10.7	1550	59.7	3.58	47.4	105.6	4.88	9.9	1350	44.2	30.7	0.70	3.37	55.7	13.1	7.3
	9.0	2.0	4.5	1350	61.3	3.81	48.3	112.0	4.71	11.1	1550	63.3	3.73	50.6	107.8	4.97	10.2	1350	45.8	34.0	0.74	3.45	57.5	13.3	7.7
	12.0	3.2	7.3	1350	63.1	3.85	50.0	113.3	4.81	11.4	1550	65.3	3.78	52.4	109.0	5.07	10.6	1350	47.2	34.4	0.73	3.34	58.6	14.1	7.3
100	6.0	1.0	2.3	Operation not recommended							Operation not recommended														
	9.0	1.9	4.4	Operation not recommended							Operation not recommended														
	12.0	3.1	7.1	1350	43.4	30.4	0.70	3.64	55.8	11.9	8.4	1550	44.8	33.6	0.75	3.69	57.4	12.2	9.1						
110	6.0	1.0	2.2	Operation not recommended							Operation not recommended														
	9.0	1.8	4.2	Operation not recommended							Operation not recommended														
	12.0	2.9	6.8	1350	39.2	28.3	0.72	3.96	52.7	9.9	10.3	1550	40.3	31.3	0.78	3.99	53.9	10.1	11.2						
120	6.0	0.9	2.1	Operation not recommended							Operation not recommended														
	9.0	1.7	4.0	Operation not recommended							Operation not recommended														
	12.0	2.8	6.5	1350	36.4	27.1	0.74	4.41	51.4	8.3	12.5	1550	37.3	29.9	0.80	4.40	52.3	8.5	13.5						

GTZ049 Low Speed - Performance Data

1350 CFM Rated Airflow

EWT °F	Flow gpm	WPD		HEATING - EAT 70°F							COOLING - EAT 80/67 °F																							
		PSI	FT	Airflow cfm	HC kBtuh	Power kW	HE kBtuh	LAT °F	COP	HWC kBtuh	Airflow cfm	TC kBtuh	SC kBtuh	S/T Ratio	Power kW	HR kBtuh	EER	HWC kBtuh																
20	5.0	0.9	2.2	Operation not recommended							Operation not recommended																							
	8.0	2.0	4.6	Operation not recommended							Operation not recommended																							
	11.0	3.4	7.8	1150	22.5	2.07	15.4	88.1	3.18	4.2	1350	23.3	2.10	16.2	86.0	3.25	3.8																	
30	5.0	0.9	2.1	Operation not recommended							Operation not recommended																							
	8.0	1.9	4.4	1150	25.9	2.11	18.7	90.9	3.60	4.3	1350	35.9	21.1	0.59	1.19	40.0	30.2	-	1150	26.7	2.13	19.5	88.3	3.68	3.9	1350	37.2	24.9	0.67	1.27	41.5	29.4	-	
	11.0	3.3	7.6	1150	26.6	2.13	19.3	91.4	3.66	4.4	1350	36.0	21.0	0.58	1.11	39.8	32.4	-	1150	36.0	21.0	0.58	1.11	39.8	32.4	-	1350	37.0	24.8	0.67	1.18	41.0	31.3	-
40	5.0	0.9	2.0	Operation not recommended							Operation not recommended																							
	8.0	1.9	4.3	1150	29.8	2.19	22.3	94.0	3.99	4.5	1350	38.0	23.0	0.61	1.31	42.4	28.9	-	1150	30.8	2.19	23.4	91.1	4.13	4.2	1350	39.2	27.1	0.69	1.38	44.0	28.3	-	
	11.0	3.2	7.4	1150	30.8	2.20	23.2	94.8	4.09	4.7	1350	38.1	23.0	0.60	1.23	42.3	31.0	-	1150	38.1	23.0	0.60	1.23	42.3	31.0	-	1350	39.2	27.1	0.69	1.30	43.6	30.2	-
50	5.0	0.9	2.0	1150	30.8	2.18	23.4	94.8	4.14	4.8	1350	38.7	24.6	0.64	1.69	44.5	22.9	1.6	1150	33.2	2.25	25.6	96.8	4.32	4.9	1350	39.9	29.0	0.73	1.76	45.9	22.6	1.7	
	8.0	1.8	4.2	1150	33.2	2.25	25.6	96.8	4.32	4.9	1350	39.6	24.7	0.62	1.47	44.6	27.0	1.5	1150	34.5	2.24	26.9	93.7	4.52	4.5	1350	40.8	29.1	0.71	1.54	46.0	26.5	1.6	
	11.0	3.1	7.2	1150	34.5	2.27	26.8	97.8	4.46	5.1	1350	39.8	24.7	0.62	1.38	44.5	28.8	1.4	1150	35.7	2.27	27.9	94.5	4.61	4.6	1350	41.0	29.1	0.71	1.45	46.0	28.2	1.5	
60	5.0	0.8	1.9	1150	33.7	2.27	26.0	97.1	4.36	5.2	1350	38.5	24.6	0.64	1.82	44.8	21.1	2.2	1150	36.5	2.32	28.6	99.4	4.60	5.4	1350	39.7	28.9	0.73	1.91	46.2	20.9	2.4	
	8.0	1.8	4.0	1150	36.5	2.32	28.6	99.4	4.60	5.4	1350	39.2	24.7	0.63	1.62	44.7	24.2	2.1	1150	37.9	2.29	30.1	96.0	4.84	5.0	1350	40.4	29.1	0.72	1.69	46.1	23.8	2.3	
	11.0	3.0	6.9	1150	38.0	2.34	30.0	100.6	4.76	5.5	1350	39.6	24.8	0.63	1.54	44.9	25.8	1.9	1150	39.4	2.31	31.5	97.0	4.98	5.1	1350	40.8	29.2	0.72	1.61	46.3	25.4	2.2	
70	5.0	0.8	1.8	1150	36.4	2.34	28.4	99.3	4.55	5.8	1350	38.7	25.8	0.67	2.01	45.6	19.3	3.2	1150	39.6	2.39	31.4	101.8	4.86	6.0	1350	39.9	30.4	0.76	2.10	47.1	19.0	3.4	
	8.0	1.7	3.9	1150	39.6	2.39	31.4	101.8	4.86	6.0	1350	39.1	26.1	0.67	1.82	45.3	21.5	3.0	1150	41.1	2.34	33.1	98.2	5.14	5.5	1350	40.4	30.6	0.76	1.90	46.8	21.2	3.2	
	11.0	2.9	6.7	1150	41.4	2.41	33.1	103.3	5.02	6.1	1350	39.8	26.2	0.66	1.74	45.7	22.9	2.7	1150	42.9	2.36	34.9	99.4	5.33	5.7	1350	41.0	30.8	0.75	1.81	47.2	22.7	3.0	
80	5.0	0.8	1.8	1150	38.7	2.40	30.5	101.2	4.72	6.5	1350	37.5	24.7	0.66	2.19	45.0	17.1	4.4	1150	42.0	2.43	33.8	103.8	5.07	6.7	1350	38.7	29.0	0.75	2.29	46.5	16.9	4.6	
	8.0	1.6	3.8	1150	42.0	2.43	33.8	103.8	5.07	6.7	1350	37.7	25.0	0.66	2.04	44.7	18.5	4.1	1150	43.7	2.37	35.7	100.0	5.41	6.1	1350	38.8	29.4	0.76	2.12	46.1	18.3	4.4	
	11.0	2.8	6.5	1150	44.2	2.46	35.8	105.6	5.27	6.9	1350	38.6	25.2	0.65	1.95	45.2	19.8	3.8	1150	45.9	2.39	37.8	101.5	5.64	6.3	1350	39.7	29.6	0.74	2.03	46.7	19.6	4.2	
90	5.0	0.7	1.7	1150	40.8	2.46	32.5	102.9	4.87	7.2	1350	35.4	22.8	0.64	2.40	43.6	14.8	5.8	1150	44.4	2.47	36.0	105.7	5.27	7.4	1350	36.5	26.7	0.73	2.49	45.0	14.6	6.2	
	8.0	1.6	3.6	1150	44.4	2.47	36.0	105.7	5.27	7.4	1350	35.4	23.0	0.65	2.27	43.1	15.6	5.5	1150	46.2	2.39	38.1	101.7	5.67	6.9	1350	36.4	27.1	0.75	2.35	44.4	15.4	5.9	
	11.0	2.7	6.2	1150	46.8	2.50	38.3	107.7	5.50	7.7	1350	36.4	23.3	0.64	2.18	43.8	16.7	5.1	1150	48.8	2.42	40.6	103.5	5.92	7.1	1350	37.5	27.4	0.73	2.27	45.2	16.5	5.6	
100	5.0	0.7	1.7	Operation not recommended							Operation not recommended																							
	8.0	1.5	3.5	Operation not recommended							Operation not recommended																							
	11.0	2.6	6.0	1150	33.7	2.37	26.0	97.1	4.36	5.2	1350	33.7	23.7	0.70	2.55	42.4	13.2	7.1	1150	34.8	2.37	27.9	98.0	4.65	5.4	1350	34.8	27.9	0.80	2.65	43.8	13.1	7.7	
110	5.0	0.7	1.6	Operation not recommended							Operation not recommended																							
	8.0	1.5	3.4	Operation not recommended							Operation not recommended																							
	11.0	2.5	5.8	1150	30.2	2.23	0.74	2.84	39.9	10.6	9.0	1350	31.3	26.3	0.84	2.96	41.4	10.6	9.7	1150	31.7	22.8	0.72	2.76	41.1	11.5	8.3	1350	32.6	26.7	0.82	2.87	42.4	11.3
120	5.0	0.7	1.5	Operation not recommended							Operation not recommended																							
	8.0	1.4	3.3	Operation not recommended							Operation not recommended																							
	11.0	2.4	5.6	1150	27.9	2.17	0.78	3.18	38.7	8.8	11.1	1350	28.9	25.6	0.89	3.31	40.2	8.7	12.0	1150	29.5	22.2	0.75	3.08	40.0	9.6	10.3	1350	30.3	26.0	0.86	3.23	41.3	9.4

GTZ064 High Speed - Performance Data

1800 CFM Rated Airflow

EWT °F	Flow gpm	WPD		HEATING - EAT 70°F							COOLING - EAT 80/67 °F														
		PSI	FT	Airflow cfm	HC kBtuh	Power kW	HE kBtuh	LAT °F	COP	HWC kBtuh	Airflow cfm	TC kBtuh	SC kBtuh	S/T Ratio	Power kW	HR kBtuh	EER	HWC kBtuh							
20	8.0	1.8	4.2	Operation not recommended							Operation not recommended														
	12.0	3.8	8.8	Operation not recommended							Operation not recommended														
	16.0	6.5	15.1	1500	38.6	3.49	26.7	93.8	3.24	6.0	1800	39.5	3.65	27.1	90.3	3.17	5.5								
30	8.0	1.8	4.1	Operation not recommended							Operation not recommended														
	12.0	3.7	8.6	1500	44.5	3.50	32.6	97.5	3.72	6.4	1800	45.7	3.73	33.0	93.5	3.59	5.8	1500	66.4	42.5	0.64	2.35	74.4	28.3	-
	16.0	6.4	14.7	1500	45.1	3.59	32.9	97.8	3.68	6.6	1800	46.2	3.76	33.4	93.8	3.60	6.0	1500	67.1	42.9	0.64	2.31	75.0	29.1	-
1800	67.6	46.6	0.69	2.45	76.0	27.5	-																		
40	8.0	1.7	4.0	Operation not recommended							Operation not recommended														
	12.0	3.6	8.3	1500	51.2	3.74	38.5	101.6	4.02	7.0	1800	52.4	3.90	39.1	96.9	3.94	6.5	1500	69.0	43.6	0.63	2.70	78.2	25.6	-
	16.0	6.2	14.2	1500	52.0	3.80	39.0	102.1	4.01	7.3	1800	53.2	3.93	39.7	97.4	3.96	6.6	1500	69.7	44.1	0.63	2.65	78.8	26.3	-
1800	70.7	47.5	0.68	2.87	79.8	24.4	-																		
50	8.0	1.7	3.8	1500	54.6	3.89	41.3	103.7	4.11	7.6	1800	55.8	4.01	42.1	98.7	4.08	7.0	1500	70.2	44.0	0.63	3.16	80.9	22.2	3.9
	12.0	3.5	8.1	1500	57.8	3.97	44.2	105.7	4.27	7.8	1800	58.9	4.06	45.1	100.3	4.25	7.2	1500	70.9	44.4	0.63	3.09	81.4	22.9	3.7
	16.0	6.0	13.8	1500	58.7	4.01	45.1	106.3	4.29	8.1	1800	60.0	4.11	46.0	100.9	4.28	7.4	1500	71.6	44.9	0.63	3.04	82.0	23.6	3.4
1800	73.0	48.7	0.67	3.23	84.0	22.6	3.8																		
60	8.0	1.6	3.7	1500	61.3	4.15	47.1	107.8	4.32	8.5	1800	62.6	4.22	48.2	102.2	4.34	7.9	1500	68.6	43.6	0.64	3.41	80.2	20.1	4.8
	12.0	3.4	7.8	1500	64.1	4.22	49.7	109.6	4.44	8.8	1800	65.5	4.28	50.9	103.7	4.48	8.1	1500	69.2	44.0	0.64	3.34	80.6	20.7	4.5
	16.0	5.8	13.4	1500	65.5	4.27	50.9	110.4	4.49	9.1	1800	66.9	4.32	52.2	104.4	4.54	8.3	1500	69.9	44.5	0.64	3.28	81.1	21.3	4.1
1800	71.7	48.3	0.67	3.49	83.6	20.6	4.6																		
70	8.0	1.6	3.6	1500	68.0	4.45	52.8	112.0	4.47	9.6	1800	69.5	4.47	54.2	105.7	4.55	8.9	1500	69.1	44.0	0.64	3.79	82.1	18.3	6.0
	12.0	3.3	7.5	1500	70.5	4.51	55.1	113.5	4.57	9.9	1800	72.1	4.52	56.6	107.1	4.67	9.1	1500	71.3	47.8	0.67	4.03	85.0	17.7	6.4
	16.0	5.6	12.9	1500	72.3	4.57	56.7	114.6	4.64	10.2	1800	73.9	4.57	58.4	108.0	4.74	9.4	1500	70.5	44.8	0.64	3.65	82.9	19.3	5.2
1800	72.7	48.7	0.67	3.88	86.0	18.7	5.8																		
80	8.0	1.5	3.5	1500	74.7	4.74	58.5	116.1	4.62	10.8	1800	76.4	4.71	60.3	109.3	4.75	10.0	1500	65.1	42.5	0.65	4.11	79.1	15.8	7.6
	12.0	3.2	7.3	1500	76.5	4.80	60.1	117.2	4.67	11.1	1800	78.3	4.75	62.1	110.3	4.83	10.3	1500	67.5	46.2	0.68	4.38	82.5	15.4	8.0
	16.0	5.4	12.5	1500	78.8	4.86	62.2	118.6	4.75	11.5	1800	80.7	4.80	64.4	111.5	4.93	10.6	1500	65.8	42.9	0.65	4.03	79.6	16.3	7.1
1800	68.2	46.6	0.68	4.28	82.8	15.9	7.7																		
90	8.0	1.4	3.3	1500	81.5	5.06	64.2	120.3	4.71	12.1	1800	83.4	4.99	66.4	112.9	4.90	11.2	1500	59.9	40.9	0.68	4.40	74.9	13.6	9.5
	12.0	3.0	7.0	1500	82.5	5.12	65.1	120.9	4.72	12.5	1800	84.6	5.01	67.5	113.5	4.95	11.6	1500	62.6	44.5	0.71	4.69	78.6	13.3	10.1
	16.0	5.2	12.0	1500	85.4	5.18	67.7	122.7	4.83	12.9	1800	87.6	5.06	70.3	115.1	5.07	11.9	1500	60.6	41.3	0.68	4.32	75.3	14.0	8.9
1800	63.1	44.9	0.71	4.59	78.8	13.7	9.6																		
100	8.0	1.4	3.2	Operation not recommended							Operation not recommended														
	12.0	2.9	6.8	Operation not recommended							Operation not recommended														
	16.0	5.0	11.6	1500	58.9	40.2	0.68	4.77	75.2	12.3	11.0	1800	61.7	43.7	0.71	5.08	79.0	12.1	12.0						
1500	59.4	40.7	0.68	4.68	75.4	12.7	10.2																		
110	8.0	1.3	3.1	Operation not recommended							Operation not recommended														
	12.0	2.8	6.5	Operation not recommended							Operation not recommended														
	16.0	4.8	11.2	1500	52.1	36.8	0.71	5.10	69.5	10.2	13.5	1800	54.9	39.9	0.73	5.44	73.4	10.1	14.6						
1500	52.6	37.2	0.71	5.01	69.6	10.5	12.5																		
120	8.0	1.3	3.0	Operation not recommended							Operation not recommended														
	12.0	2.7	6.3	Operation not recommended							Operation not recommended														
	16.0	4.6	10.7	1500	50.7	37.4	0.74	5.63	69.9	9.0	16.3	1800	53.6	40.7	0.76	6.01	74.1	8.9	17.7						
1500	51.1	37.8	0.74	5.52	70.0	9.3	15.2																		
1800	54.1	41.1	0.76	5.91	74.3	9.2	16.8																		

GTZ064 Low Speed - Performance Data

1500 CFM Rated Airflow

EWT °F	Flow gpm	WPD		HEATING - EAT 70°F							COOLING - EAT 80/67 °F														
		PSI	FT	Airflow cfm	HC kBtuh	Power kW	HE kBtuh	LAT °F	COP	HWC kBtuh	Airflow cfm	TC kBtuh	SC kBtuh	S/T Ratio	Power kW	HR kBtuh	EER	HWC kBtuh							
20	6.0	1.0	2.4	Operation not recommended							Operation not recommended														
	10.0	2.7	6.2	Operation not recommended							Operation not recommended														
	14.0	5.1	11.8	1250	25.6	2.55	16.9	89.0	2.95	4.8	1500	26.5	2.58	17.7	86.4	3.01	4.4								
30	6.0	1.0	2.3	Operation not recommended							Operation not recommended														
	10.0	2.6	6.0	1250	29.7	2.63	20.8	92.0	3.32	4.9	1500	30.8	2.66	21.7	89.0	3.39	4.5	1250	50.7	29.8	0.59	1.43	55.6	35.4	-
	14.0	5.0	11.5	1250	30.8	2.63	21.8	92.8	3.44	5.0	1500	31.9	2.66	22.8	89.7	3.51	4.6	1250	50.8	29.7	0.59	1.40	55.6	36.4	-
1500	52.1	33.9	0.65	1.47	57.1	35.4	-																		
40	6.0	1.0	2.3	Operation not recommended							Operation not recommended														
	10.0	2.5	5.9	1250	35.1	2.72	25.8	96.0	3.78	5.2	1500	36.1	2.73	26.8	92.3	3.87	4.8	1250	52.2	30.5	0.59	1.57	57.5	33.2	-
	14.0	4.8	11.1	1250	36.2	2.73	26.9	96.8	3.89	5.3	1500	37.2	2.74	27.9	93.0	3.98	4.9	1250	52.3	30.5	0.58	1.54	57.6	34.1	-
1500	53.7	34.7	0.65	1.62	59.2	33.3	-																		
50	6.0	0.9	2.2	1250	39.5	2.76	30.1	99.3	4.19	5.4	1500	40.6	2.76	31.1	95.0	4.30	5.0	1250	53.4	31.0	0.58	1.82	59.6	29.4	2.0
	10.0	2.5	5.7	1250	40.1	2.81	30.5	99.7	4.18	5.6	1500	41.0	2.79	31.5	95.3	4.30	5.2	1250	53.6	31.2	0.58	1.75	59.6	30.6	1.8
	14.0	4.7	10.8	1250	41.3	2.83	31.7	100.6	4.28	5.8	1500	42.2	2.81	32.6	96.1	4.40	5.3	1250	53.7	31.2	0.58	1.72	59.6	31.2	1.7
1500	55.3	35.4	0.64	1.80	61.4	30.7	1.9																		
60	6.0	0.9	2.1	1250	44.0	2.85	34.2	102.6	4.52	6.0	1500	44.9	2.83	35.2	97.7	4.65	5.5	1250	51.5	30.3	0.59	2.03	58.5	25.4	2.8
	10.0	2.4	5.5	1250	45.3	2.90	35.4	103.6	4.58	6.2	1500	46.0	2.86	36.3	98.4	4.72	5.7	1250	51.7	30.6	0.59	1.97	58.5	26.3	2.6
	14.0	4.5	10.4	1250	46.4	2.93	36.4	104.4	4.64	6.4	1500	47.1	2.89	37.3	99.1	4.78	5.8	1250	52.0	30.6	0.59	1.93	58.5	27.0	2.4
1500	53.5	34.6	0.65	2.01	60.4	26.6	2.7																		
70	6.0	0.9	2.0	1250	48.3	2.94	38.3	105.8	4.81	6.6	1500	49.1	2.89	39.2	100.3	4.98	6.1	1250	50.6	30.6	0.61	2.29	58.5	22.1	3.9
	10.0	2.3	5.3	1250	50.3	2.99	40.1	107.3	4.93	6.8	1500	50.9	2.93	40.9	101.4	5.10	6.3	1250	50.9	30.9	0.61	2.23	58.5	22.8	3.7
	14.0	4.4	10.1	1250	51.3	3.02	41.0	108.0	4.97	7.0	1500	51.9	2.96	41.8	102.0	5.14	6.5	1250	51.3	31.0	0.61	2.18	58.7	23.5	3.4
1500	52.8	34.9	0.66	2.28	60.6	23.2	3.8																		
80	6.0	0.9	2.0	1250	52.4	3.03	42.0	108.8	5.06	7.4	1500	52.9	2.97	42.7	102.6	5.22	6.8	1250	48.4	29.6	0.61	2.59	57.3	18.7	5.4
	10.0	2.2	5.1	1250	55.3	3.08	44.8	111.0	5.26	7.6	1500	55.6	2.99	45.4	104.3	5.45	7.0	1250	48.8	29.9	0.61	2.53	57.5	19.3	5.1
	14.0	4.2	9.8	1250	56.0	3.12	45.3	111.5	5.25	7.9	1500	56.2	3.03	45.8	104.7	5.43	7.3	1250	49.2	30.1	0.61	2.49	57.6	19.7	4.7
1500	50.7	33.6	0.66	2.58	59.5	19.7	5.2																		
90	6.0	0.8	1.9	1250	56.3	3.12	45.7	111.7	5.29	8.3	1500	56.5	3.04	46.1	104.8	5.44	7.6	1250	44.9	28.1	0.63	2.93	54.9	15.3	7.2
	10.0	2.1	5.0	1250	60.1	3.17	49.3	114.5	5.55	8.5	1500	60.1	3.06	49.7	107.1	5.76	7.9	1250	46.2	31.2	0.67	3.01	56.5	15.3	7.7
	14.0	4.1	9.4	1250	60.5	3.22	49.5	114.8	5.51	8.8	1500	60.4	3.11	49.8	107.3	5.70	8.1	1250	45.4	28.3	0.62	2.86	55.1	15.8	6.8
1500	46.7	31.6	0.68	2.96	56.8	15.8	7.3																		
100	6.0	0.8	1.8	Operation not recommended							Operation not recommended														
	10.0	2.1	4.8	Operation not recommended							Operation not recommended														
	14.0	3.9	9.1	Operation not recommended							Operation not recommended														
1250	43.5	28.4	0.65	3.27	54.6	13.3	8.8																		
1500	44.8	31.4	0.70	3.36	56.2	13.3	9.5																		
1250	43.9	28.8	0.66	3.23	54.9	13.6	8.2																		
1500	45.3	31.8	0.70	3.31	56.6	13.7	9.1																		
110	6.0	0.8	1.8	Operation not recommended							Operation not recommended														
	10.0	2.0	4.6	Operation not recommended							Operation not recommended														
	14.0	3.8	8.7	Operation not recommended							Operation not recommended														
1250	39.1	26.8	0.69	3.71	51.8	10.6	11.1																		
1500	40.4	29.5	0.73	3.78	53.3	10.7	12.1																		
1250	39.7	27.3	0.69	3.65	52.1	10.9	10.3																		
1500	40.9	29.9	0.73	3.73	53.6	11.0	11.5																		
120	6.0	0.7	1.7	Operation not recommended							Operation not recommended														
	10.0	1.9	4.4	Operation not recommended							Operation not recommended														
	14.0	3.6	8.4	Operation not recommended							Operation not recommended														
1250	36.6	27.0	0.74	4.20	50.9	8.7	13.8																		
1500	37.7	29.4	0.78	4.25	52.2	8.9	14.9																		
1250	37.1	27.5	0.74	4.15	51.3	8.9	12.8																		
1500	38.3	29.9	0.78	4.20	52.6	9.1	14.2																		

GTZ072 High Speed - Performance Data

2200 CFM Rated Airflow

EWT °F	Flow gpm	WPD		HEATING - EAT 70°F							COOLING - EAT 80/67 °F															
		PSI	FT	Airflow cfm	HC kBtuh	Power kW	HE kBtuh	LAT °F	COP	HWC kBtuh	Airflow cfm	TC kBtuh	SC kBtuh	S/T Ratio	Power kW	HR kBtuh	EER	HWC kBtuh								
20	12.0	3.3	7.6	Operation not recommended							Operation not recommended															
	15.0	4.6	10.7	Operation not recommended							Operation not recommended															
	18.0	6.2	14.3	1850	44.9	4.15	30.8	92.5	3.17	7.8	2200	46.6	4.42	31.5	89.6	3.09	7.1									
30	12.0	3.2	7.4	Operation not recommended							Operation not recommended															
	15.0	4.5	10.4	1850	52.1	4.31	37.4	96.1	3.54	8.2	2200	53.9	4.59	38.3	92.7	3.44	7.6	1850	71.7	43.7	0.61	2.55	80.4	28.1	-	
	18.0	6.0	13.9	1850	52.5	4.35	37.7	96.3	3.54	8.5	2200	54.5	4.63	38.7	92.9	3.45	7.7	1850	72.4	44.5	0.61	2.51	81.0	28.9	-	
				2200	54.5	4.63	38.7	92.9	3.45	7.7	2200	73.8	47.9	0.65	2.66	82.8	27.7	-								
40	12.0	3.1	7.1	Operation not recommended							Operation not recommended															
	15.0	4.4	10.1	1850	60.4	4.58	44.8	100.2	3.87	9.1	2200	62.5	4.79	46.1	96.3	3.82	8.4	1850	74.6	46.6	0.62	3.08	85.1	24.2	-	
	18.0	5.8	13.5	1850	61.2	4.63	45.4	100.7	3.88	9.4	2200	63.4	4.84	46.8	96.7	3.84	8.5	1850	75.3	47.4	0.63	3.02	85.6	24.9	-	
				2200	63.4	4.84	46.8	96.7	3.84	8.5	2200	76.8	51.0	0.66	3.22	87.7	23.9	-								
50	12.0	3.0	6.9	1850	64.3	4.77	48.0	102.2	3.95	9.8	2200	66.5	4.94	49.6	98.0	3.94	9.1	1850	75.9	48.4	0.64	3.74	88.7	20.3	4.3	
	15.0	4.2	9.8	1850	67.9	4.86	51.3	104.0	4.09	10.1	2200	70.2	5.02	53.0	99.5	4.10	9.3	1850	76.7	48.9	0.64	3.66	89.2	21.0	4.0	
	18.0	5.7	13.1	1850	69.1	4.92	52.3	104.6	4.12	10.5	2200	71.4	5.07	54.1	100.0	4.13	9.6	1850	77.5	49.9	0.64	3.60	89.8	21.5	3.7	
				2200	71.4	5.07	54.1	100.0	4.13	9.6	2200	79.0	53.7	0.68	3.83	92.1	20.6	4.1								
60	12.0	2.9	6.7	1850	72.3	5.08	54.9	106.2	4.17	11.0	2200	74.6	5.18	56.9	101.4	4.22	10.2	1850	74.6	48.5	0.65	3.97	88.1	18.8	5.3	
	15.0	4.1	9.5	1850	75.5	5.17	57.8	107.8	4.28	11.4	2200	77.9	5.25	60.0	102.8	4.35	10.5	1850	75.3	49.0	0.65	3.89	88.6	19.4	4.9	
	18.0	5.5	12.7	1850	77.2	5.23	59.3	108.6	4.32	11.7	2200	79.7	5.31	61.6	103.5	4.40	10.8	1850	76.1	49.8	0.65	3.82	89.2	19.9	4.5	
				2200	79.7	5.31	61.6	103.5	4.40	10.8	2200	77.7	53.6	0.69	4.07	91.6	19.1	5.1								
70	12.0	2.8	6.5	1850	80.3	5.40	61.9	110.2	4.36	12.4	2200	82.9	5.44	64.3	104.9	4.47	11.5	1850	74.5	49.5	0.66	4.42	89.6	16.9	6.6	
	15.0	4.0	9.1	1850	83.2	5.48	64.5	111.6	4.44	12.8	2200	85.8	5.49	67.1	106.1	4.58	11.8	1850	75.3	50.0	0.66	4.33	90.0	17.4	6.1	
	18.0	5.3	12.2	1850	85.3	5.55	66.4	112.7	4.50	13.2	2200	88.1	5.55	69.2	107.1	4.65	12.1	1850	76.1	50.5	0.66	4.25	90.6	17.9	5.7	
				2200	88.1	5.55	69.2	107.1	4.65	12.1	2200	77.6	54.4	0.70	4.53	93.1	17.1	6.3								
80	12.0	2.7	6.3	1850	87.5	5.76	67.8	113.8	4.45	14.0	2200	90.3	5.72	70.8	108.0	4.63	12.9	1850	71.3	48.2	0.68	4.75	87.5	15.0	8.3	
	15.0	3.8	8.8	1850	89.5	5.83	69.6	114.8	4.50	14.4	2200	92.4	5.76	72.7	108.9	4.70	13.3	1850	72.0	48.6	0.68	4.65	87.9	15.5	7.8	
	18.0	5.1	11.8	1850	92.2	5.91	72.1	116.2	4.57	14.8	2200	95.3	5.82	75.4	110.1	4.80	13.7	1850	72.8	49.4	0.68	4.57	88.4	15.9	7.2	
				2200	95.3	5.82	75.4	110.1	4.80	13.7	2200	74.3	53.1	0.71	4.87	90.9	15.3	8.0								
90	12.0	2.6	6.0	1850	94.7	6.13	73.8	117.4	4.53	15.7	2200	97.8	6.00	77.3	111.2	4.77	14.5	1850	66.7	45.8	0.69	4.96	83.6	13.4	10.5	
	15.0	3.7	8.5	1850	96.0	6.19	74.9	118.0	4.54	16.2	2200	99.1	6.03	78.5	111.7	4.81	15.0	1850	68.0	49.7	0.73	5.28	86.1	12.9	11.1	
	18.0	4.9	11.4	1850	99.3	6.28	77.9	119.7	4.63	16.7	2200	102.6	6.10	81.8	113.2	4.93	15.4	1850	67.3	46.2	0.69	4.86	83.9	13.9	9.8	
				2200	99.3	6.28	77.9	119.7	4.63	16.7	2200	68.7	50.2	0.73	5.18	86.3	13.3	10.6	1850	68.0	47.1	0.69	4.78	84.4	14.2	9.1
				2200	102.6	6.10	81.8	113.2	4.93	15.4	2200	69.4	50.7	0.73	5.09	86.8	13.6	10.1								
100	12.0	2.5	5.8	Operation not recommended							Operation not recommended															
	15.0	3.6	8.2	Operation not recommended							Operation not recommended															
	18.0	4.8	11.0	Operation not recommended							Operation not recommended															
				Operation not recommended							Operation not recommended															
110	12.0	2.4	5.6	Operation not recommended							Operation not recommended															
	15.0	3.4	7.9	Operation not recommended							Operation not recommended															
	18.0	4.6	10.6	Operation not recommended							Operation not recommended															
				Operation not recommended							Operation not recommended															
120	12.0	2.3	5.4	Operation not recommended							Operation not recommended															
	15.0	3.3	7.6	Operation not recommended							Operation not recommended															
	18.0	4.4	10.2	Operation not recommended							Operation not recommended															
				Operation not recommended							Operation not recommended															

Wiring Schematics

Single Speed Split - 208-230/60/1

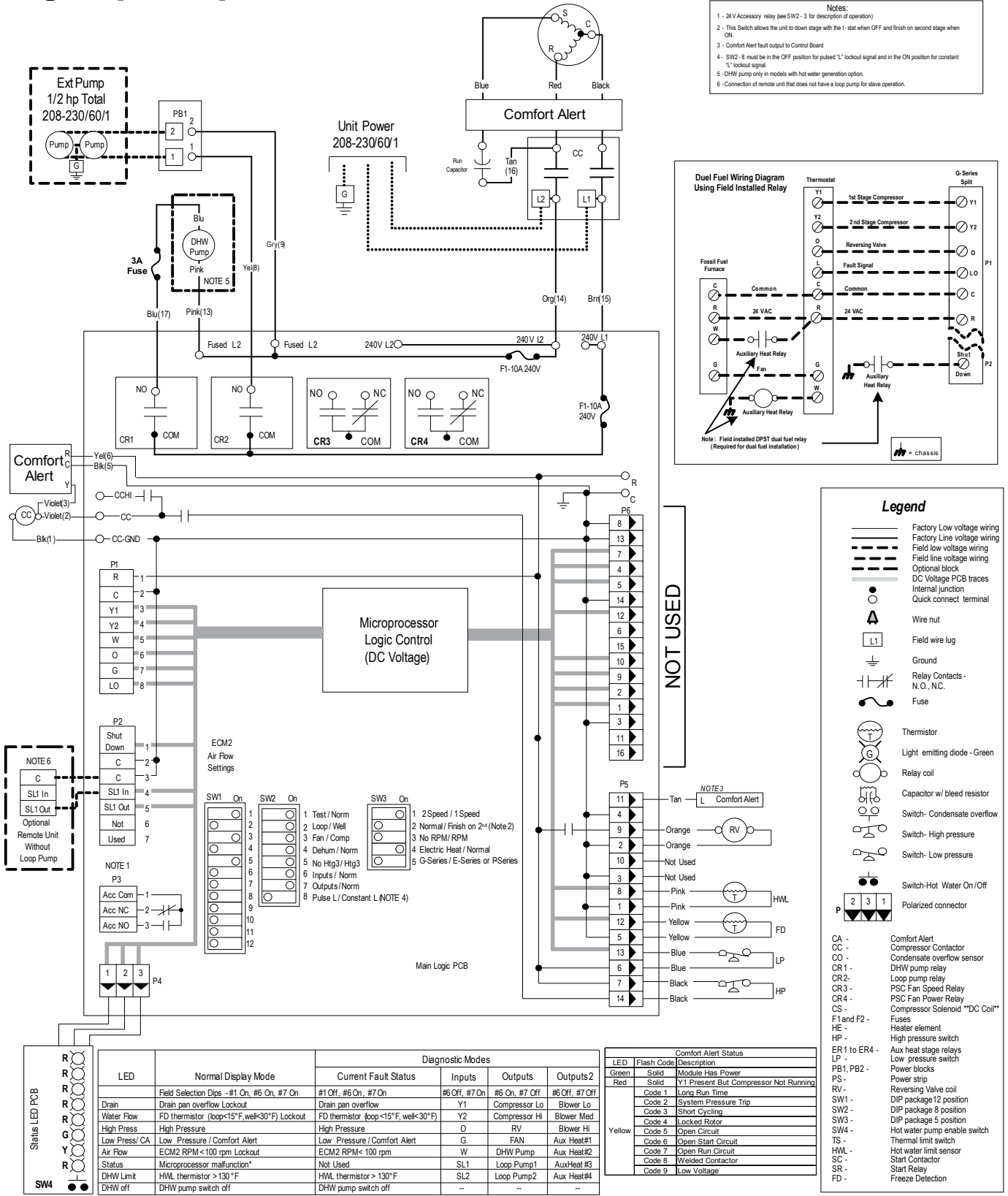

Wiring Schematics cont.

Dual Capacity Split - 208-230/60/1

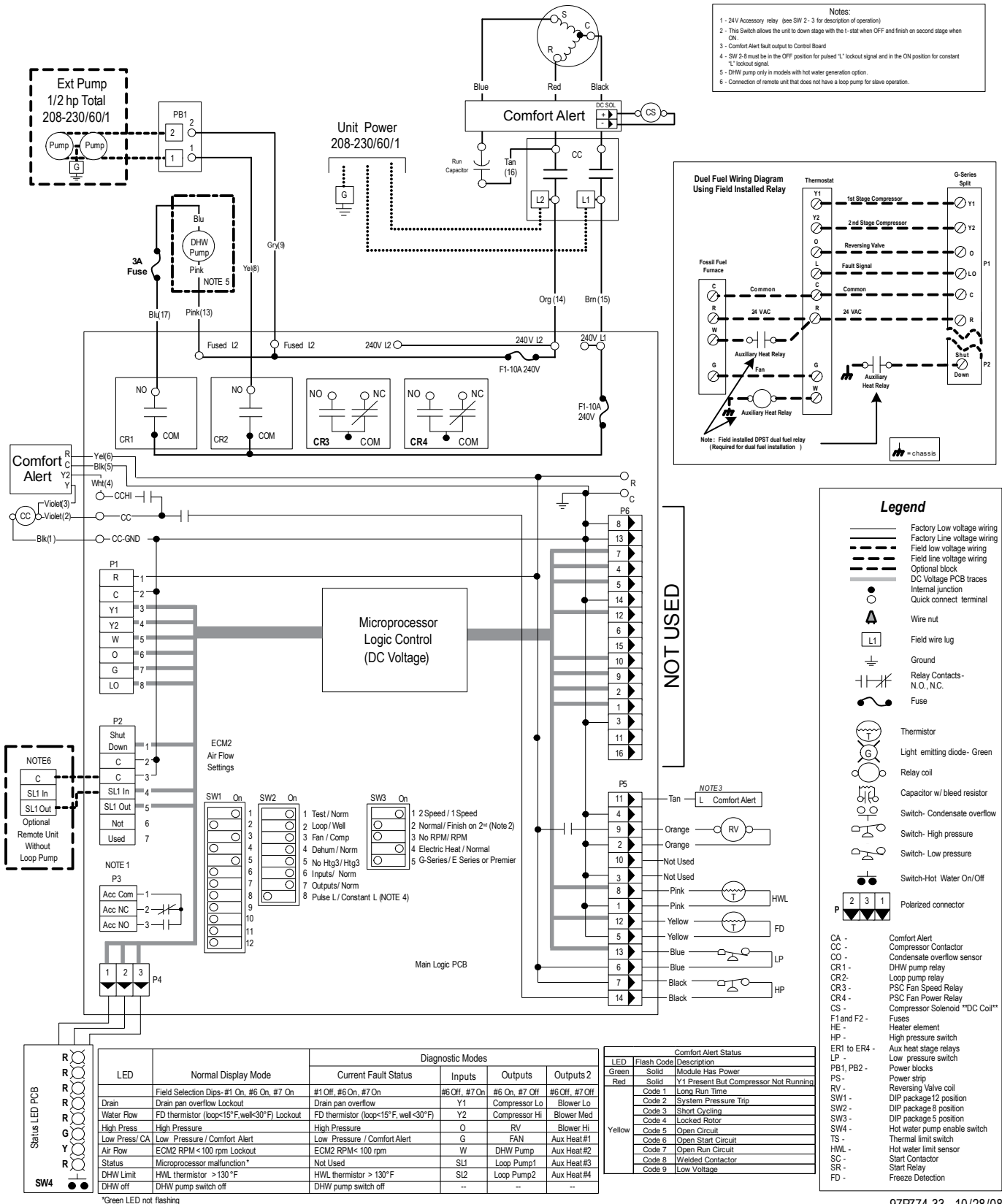

Microprocessor Control

Startup

The unit will not operate until all the inputs and safety controls are checked for normal conditions. At first power-up, a four minute delay is employed before the compressor is energized.

Component Sequencing Delays

Components are sequenced and delayed for optimum space conditioning performance.

Accessory Relay

An accessory relay on the control board allows for field connection of solenoid valves, electronic air cleaners, etc. The accessory relay has a normally open output and a normally closed output.

Short Cycle Protection

The control employs a minimum "off" time of four minutes to provide for short cycle protection of the compressor.

Shutdown Mode

A 24VAC common signal to the "shutdown" input on the control board puts the unit into shutdown mode. Compressor, hot water pump and blower operation are suspended.

Safety Controls

The G Series control receives separate signals for a high pressure switch for safety, a low pressure switch to prevent loss of charge damage, and a low suction temperature thermistor for low source water temperature sensing. Upon a continuous 30-second measurement of the fault (immediate for high pressure), compressor operation is suspended, the appropriate lockout LED begins flashing. (Refer to the "Fault Retry" section below.)

Testing

The G Series control allows service personnel to shorten most timing delays for faster diagnostics.

Fault Retry

All faults are retried twice before finally locking the unit out. An output signal is made available for a fault LED at the thermostat. The "fault retry" feature is designed to prevent nuisance service calls.

Diagnostics

The G Series control board allows all inputs and outputs to be displayed on the LEDs for fast and simple control board diagnosis.

Hot Water High Limit (Domestic Hot Water Option)

This mode occurs when the hot water input temperature is at or above 130°F for 30 continuous seconds. The DHW limit status LED on the unit illuminates and the hot water pump de-energizes. Hot water pump operations resume on the next compressor cycle or after 15 minutes of continuous compressor operation during the current thermostat demand cycle.

Hot Water Justification

Since compressor hot gas temperature is dependant on loop temperature in cooling mode, loop temperatures may be too low to allow proper heating of water. The control will monitor water and refrigerant temperatures to determine if conditions are satisfactory for heating water. The DHW limit status LED on the unit illuminates when conditions are not favorable for heating water.

Heating Operation

Heat, 1st Stage (Y1)

The blower motor is started immediately, the loop pump is energized 5 seconds after the "Y1" input is received, and the compressor is energized on low capacity 10 seconds after the "Y1" input. The hot water pump is cycled 30 seconds after the "Y1" input.

Heat, 2nd Stage (Y1,Y2) Single-Speed Units

The hot water pump is de-energized, which directs all heat to satisfying the thermostat, and the blower changes to high speed 15 seconds after the "Y2" input (ECM only).

Heat, 2nd Stage (Y1,Y2) Dual Capacity Units

The second stage compressor will be activated 5 seconds after receiving a "Y2" input as long as the minimum first stage compressor run time of 1 minute has expired. The ECM blower changes from medium to high speed 15 seconds after the "Y2" input.

The Comfort Alert will delay the second stage compressor until 5 seconds after it receives a "Y2" from the board.

Heat, 3rd Stage (Y1,Y2,W) Single-Speed Units

The first stage of resistance heat is energized 10 seconds after "W" input, and with continuous 3rd stage demand, the additional stages of resistance heat engage 90 seconds after the first stage.

Heat, 3rd Stage (Y1,Y2,W) Dual Capacity Units

The hot water pump is de-energized which directs all heat to satisfy the thermostat. The 1st stage of resistance heat is energized 10 seconds after "W" input, and with continuous 3rd stage demand, the additional stages of resistance heat engage 90 seconds after the first stage.

Emergency Heat (W only)

The blower is started on high speed, and the first stage of resistance heat is energized 10 seconds after the "W" input. Continuing demand will engage the additional stages of resistance heat 90 seconds after the first stage.

Cooling Operation

In all cooling operations, the reversing valve directly tracks the "O" input. Thus, anytime the "O" input is present, the reversing valve will be energized.

Cool, 1st Stage (Y1,O)

The blower motor and hot water pump are started immediately, the loop pump(s) is energized 5 seconds after the

Microprocessor Control cont.

“Y1” input is received. The compressor will be energized (on low capacity for Dual Capacity units) 10 seconds after the “Y1” input. The ECM blower will operate at 85% of medium speed if in dehumidification mode.

Cool, 2nd Stage (Y1, Y2, O) Single Speed Units

The blower changes to high speed (85% of high speed if in dehumidification mode) 15 seconds after the “Y2” input (ECM only).

Cool, 2nd Stage (Y1, Y2, O) Dual Capacity Units

The second stage compressor will be activated 5 seconds after receiving a “Y2” input as long as the minimum first stage compressor run time of 1 minute has expired. The ECM blower changes to high speed 15 seconds after the “Y2” input (85% of high speed if in dehumidification mode). The Comfort Alert will delay the second stage compressor until 5 seconds after it receives a “Y2” from the board.

Blower (G only)

The blower starts and operates on low speed.

Lockout Conditions

During lockout mode, the appropriate unit and thermostat lockout LEDs will illuminate. The compressor, loop pump, hot water pump, and accessory outputs are de-energized. The blower will continue to run on low speed. If the thermostat calls for heating, emergency heat operation will occur.

Comfort Alert lockouts cannot be reset at the thermostat. All other lockout modes can be reset at the thermostat after turning the unit off, then on, which restores normal operation but keeps the unit lockout LED illuminated. Interruption of power to the unit will reset a lockout without a waiting period and clear all lockout LEDs.

High Pressure

This lockout mode occurs when the normally closed safety switch is opened momentarily (set at 600 PSI).

Low Pressure

This lockout mode occurs when the normally closed low pressure switch is opened for 30 continuous seconds (set at 40 PSI). A low pressure fault may also be indicated when a Comfort Alert lockout has occurred.

Freeze Detection (Water Flow)

This lockout mode occurs when the freeze detection thermistor temperature is at or below the selected point (well 30°F or loop 15°F) for 30 continuous seconds.

Microprocessor Control cont.

Thermostat Displays

Fault Flash

When using a TA32W02 or TP32W03 thermostat and SW2-8 is in the pulsing "L" position, FaultFlash will enable a user to view the thermostat and count the fault indicator flashes to determine the lockout condition the unit is experiencing.

ComforTalk

When using a TP32U03, 04 or 05 thermostat and SW2-8 is in the pulsing "L" position, ComforTalk will enable the user to view the thermostat and determine the fault. The thermostat can be configured to show either lockout text or lockout codes.

The LED board on the front of the unit will display all lockouts. The Low Pressure LED will flash for a low pressure condition or a Comfort Alert fault. If the low pressure lockout was caused by Comfort Alert codes 4, 6 or 7, then the Comfort Alert will be flashing. If no Comfort Alert code is visible, then it is a low pressure lockout.

The following tables show the codes that will be displayed on the different ComforTalk and FaultFlash thermostats.

FaultFlash Thermostats

TA32W02 and TP32W03 Thermostats	
Thermostat Display Lockout Code	Lockout Description
2 Flashes	High Pressure Fault
3 Flashes	Low Pressure Fault
4 Flashes	Not Applicable
5 Flashes	Water Flow Fault
6 Flashes	Not Applicable
7 Flashes	Condensate Fault
8 Flashes	Voltage out of Range
9 Flashes	RPM Fault
10 Flashes	Comfort Alert Compressor Module Fault

Lockout code 10 - see Comfort Alert module to determine the specific flash code for compressor abnormalities.

ComforTalk Thermostats

TP32U03, TP32U04 and TP32U05 Thermostats	
Thermostat Display Lockout Code	Lockout Description
"High Pressure" or "E2"	High Pressure Fault
"Low Pressure" or "E3"	Low Pressure Fault
"E4"	Not Applicable
"Water Flow" or "E5"	Water Flow Fault
"E6"	Not Applicable
"Condensate" or "E7"	Condensate Fault
"Voltage Range" or "E8"	Voltage out of Range
"RPM" or "E9"	RPM Fault
"Comfort Alert" or "E10"	Comfort Alert Compressor Module Fault

These thermostats can be configured to display the lockout condition "text" or error number. * A slow flash of 1 second on and off means the heat pump microprocessor SW2-1 is configured for "Test Mode" or thermostat is miswired.

Lockout code 10 - see Comfort Alert module to determine the specific flash code for compressor abnormalities.

Thermostat Wiring

Indoor Split Single and Dual Capacity Wiring Diagram

Field low voltage point to point wiring:

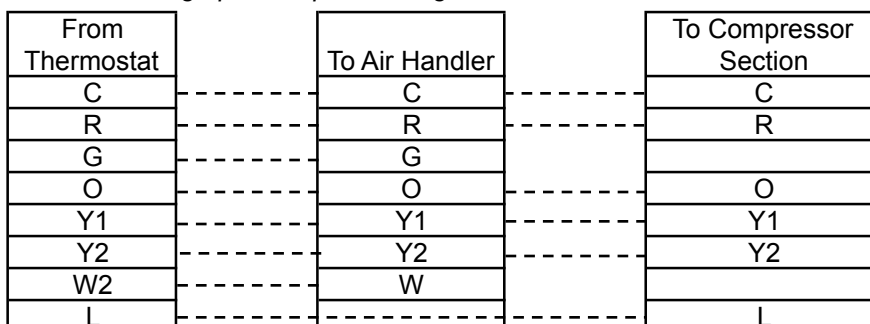

Air Handler transformer must be 75VA.

5/29/08

Engineering Guide Specifications

General

The geothermal heating/cooling units shall be reverse cycle split system configuration designed for use with DX heating and cooling coils. Units shall be AHRI/ISO Standard 13256-1 performance certified and listed by a nationally recognized safety-testing laboratory or agency, such as ETL Testing Laboratory. Each unit shall be computer run-tested at the factory using water and performance verified. Each unit shall be mounted on a pallet and stretch-wrapped for shipping protection. The geothermal units shall be designed to operate with entering liquid temperature between 25°F and 110°F as manufactured.

Casing and Cabinet

The cabinet shall be fabricated from heavy-gauge steel and finished with corrosion-resistant epoxy/polyester powder coating. The interior shall be insulated with 1/2-inch thick, multi-density, coated glass fiber. The cabinet shall have three access panels for ease of installation and servicing. The internal layout shall provide for major component servicing through front service panel in restricted access installations.

Refrigerant Circuit

All units shall contain an environmentally friendly R410A sealed refrigerant circuit including a hermetic motor-compressor, thermostatic expansion valve, reversing valve, coaxial tube water-to-refrigerant heat exchanger, and service ports. Compressors shall be high-efficiency scroll dual capacity or single speed type designed for heat pump duty and mounted on double, rubber vibration isolators on a metal core. Compressor motors shall be heat pump rated single-phase PSC with internal overload protection. The coaxial water-to-refrigerant heat exchanger shall be designed for low water pressure drop and constructed of a convoluted copper (cupronickel optional) inner tube and a steel outer tube. The bidirectional thermostatic expansion valve shall provide proper superheat over the entire liquid temperature range with minimal "hunting". The refrigerant suction lines shall be insulated to prevent condensation at low liquid temperatures. An optional ThermaShield coated hot water generator coil shall be provided with integral internal pump and limit controls. All units shall have the source coaxial tube refrigerant-to-water heat exchanger ThermaShield coated.

Electrical

The microprocessor control shall provide operational sequencing, high and low-pressure switch monitoring, thermistor based freeze detection temperature limit, current sensing compressor monitoring, compressor lockout mode control and hot water generator and loop pump control. A removable terminal connector with screw terminals shall be provided for field control wiring on the board. The control shall provide water valve control, test mode, diagnostic mode, short cycle protection, random startup, pump slaving, fault LEDs, status LEDs, and intelligent fault retry.

Quick attach wiring harnesses shall be employed throughout to aid in troubleshooting or parts replacement. Line voltage box lugs shall be provided for both field power wiring connections for unit and the fused external loop pumps. All units shall have knockouts for entrance of low and line voltage wiring.

Optional GeoStart™

GeoStart is a single phase soft starter which reduces the normal start current (LRA) by 60-70%. This allows the heat pump to more easily go "off grid." Using GeoStart will also provide a substantial reduction in light flicker, reduce start-up noise, and improve the compressor's start behavior. GeoStart is available as a factory option or field retrofit kit for all G Series split units.

Piping

Supply and return water as well as hot water generator connections shall be 1" FPT brass swivel fittings which provide a union and eliminate the need for backup wrenches or sealants when making field connections. All water piping shall be insulated to prevent condensation at low entering liquid temperatures.

Accessories and Options

Hot Water Generator

An optional hot water assist generator coil shall be provided with integral factory-mounted internal pump. The coil shall be of convoluted double construction and suitable for potable water. Limit controls shall monitor the compressor hot gas temperature and hot water temperature and disable operation during low compressor hot gas temperatures to prevent thermosiphoning from the water heater and limit high water temperatures to prevent scalding.

Thermostat (field-installed)

A multi-stage auto-changeover electronic digital thermostat shall be provided. The thermostat shall offer three heating and two cooling stages with precise temperature control. An OFF-HEAT-AUTO-COOL-EMERG system switch, OFF-AUTO blower switch, and indicating LEDs shall be provided. The thermostat shall display in °F or °C. An optional remote outdoor sensor shall be available.

Flow Center (field installed)

A self contained Flow Center shall provide all pumping, flushing and filling operations needed for residential geothermal earth loops up to 20 gpm. Two corrosion resistant composite 3-way valves shall be employed for loop valving. The flow center shall provide 1" FPT or special 'GL' composite union fittings for easy adaptation to connection options. The GL flow controller shall be encased in a corrosion proof polystyrene case (FPT case is powder coated metal) and fully insulated with urethane foam to prevent condensation.



Product: **Aston Series Indoor Split**
Type: Geothermal Heat Pumps
Size: 2 - 6 Tons Single Speed
2 - 6 Tons Dual Capacity

Document Type: Specification Catalog
Part Number: SC1003SG
Release Date: 02/11