



INSTALLATION MANUAL

GEO THERMAL HEAT PUMPS



AFFORDABLE RENEWABLE CLEAN



ASTON SERIES

Table of Contents

Model Nomenclature	4
General Installation Information	5
Closed Loop Ground Source Systems.....	9
Open Loop Ground Water Systems.....	11
Electrical Connections.....	12
Electronic Thermostat Installation.....	13
Auxiliary Heat Ratings.....	14
Auxiliary Heat Electrical Data	14
Electrical Data	15
Blower Performance Data.....	16
Dimensional Data.....	18
Physical Data.....	21
The Aurora™ Control System	22
Reference Calculations and Legend	31
Operating Limits.....	31
Wiring Schematics.....	32
Unit Startup.....	40
Antifreeze Corrections	42
Correction Factor Tables.....	43
Operating Parameters	44
Pressure Drop	45
Compressor and Thermistor Resistance.....	46
Refrigerant Circuit Guideline	46
Heat of Extraction/Rejection	47
Troubleshooting	48
Preventive Maintenance	52
Replacement Procedures	52
Service Parts List	53

Model Nomenclature

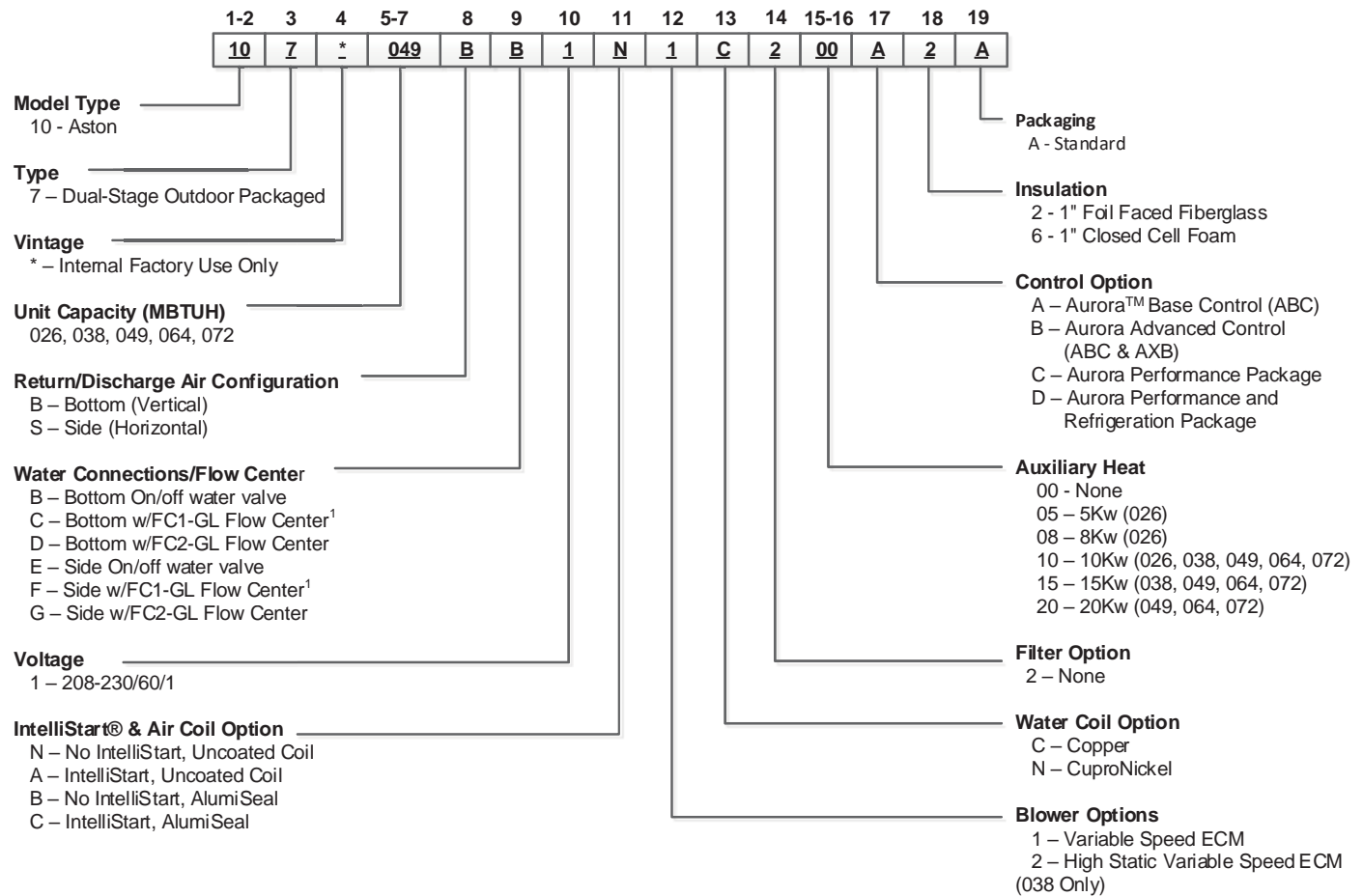

Rev.: 9/28/17C

Notes:
All Models include sound kits as std. equipment
¹FC1-GL not available in 064-072 units.

General Installation Information



WARNING: Before performing service or maintenance operations on a system, turn off main power switches to the unit. If applicable, turn off the accessory heater power switch. Electrical shock could cause personal injury.

Installing and servicing heating and air conditioning equipment can be hazardous due to system pressure and electrical components. Only trained and qualified service personnel should install, repair or service heating and air conditioning equipment. Untrained personnel can perform the basic maintenance functions of cleaning coils and cleaning and replacing filters. All other operations should be performed by trained service personnel. When working on heating and air conditioning equipment, observe precautions in the literature, tags and labels attached to the unit and other safety precautions that may apply.

Follow all safety codes. Wear safety glasses and work gloves. Use a quenching cloth for brazing operations and have a fire extinguisher available.

Moving and Storage

Move units in the normal “up” orientation. Do not stack more than two units in total height. Do not attempt to move units while stacked. When the equipment is received, all items should be carefully checked against the bill of lading to be sure all crates and cartons have been received. Examine units for shipping damage, removing the units from the packaging only if necessary. Units in question should also be internally inspected. If any damage is noted, the carrier should make the proper notation on the delivery receipt, acknowledging the damage.

Exercise care when moving the unit. Do not remove any packaging until the unit is near the place of installation. Rig the unit by attaching chain or cable slings to the lifting holes provided in the base rails. Spreader bars, whose length exceeds the largest dimension across the unit, **MUST** be used across the top of the unit.



If a unit is to be installed on a roof curb gasketing must be applied to all surfaces that come in contact with the unit underside.



Before lifting, make sure the unit weight is distributed equally on the rigging cables so it will lift evenly.

Units may be moved or lifted with a forklift. Slotted openings in the base rails are provided for this purpose. Fork must be at least 59 inches long.



All panels must be secured in place when the unit is lifted.

Unit Location

Locate the Packaged Heat Pump away from areas that may disturb the customer and in a way that allows easy removal of the access panels and the top of the cabinet. Provide sufficient room to make water and electrical connections, and allow space for service personnel to perform maintenance. The Packaged Heat Pump is approved for outdoor installation when properly installed. Open loop applications are to be installed in locations where the ambient temperature never drops below 32°F. Failure to do so will result in failure of the heat pump. Closed loop applications need to ensure that antifreeze is used to ensure the freeze protection is below the ambient temperature.

Fork Pocket Covers

There are eight fork pocket covers and mounting screws provided with the unit. Once the heat pump is set in place, secure the fork pocket covers to the base rails with provided screws to close off the base rail openings.



General Installation Information cont.

Slab Mounted Units

The unit should be set on a solid, level foundation, preferably a concrete slab. The slab is to be constructed to local building codes and support unit weight. Maintain level tolerance to 1/8" across width and length of unit. Any slab used as a unit's foundation should not adjoin the building as it is possible that sound and vibration may be transmitted to the structure. Slab should be at least 2" above grade. The slab should be surrounded by a gravel apron to allow for good drainage. The slab should extend 2" beyond the cabinet on all 4 sides of the unit. Do not secure the unit to the slab EXCEPT when required by local codes. If heat pump has bottom water connections provisions need to be made for piping connections.

After setting the unit in place, remove and discard the compressor hold down shipping bolt located at the front of the compressor mounting bracket.

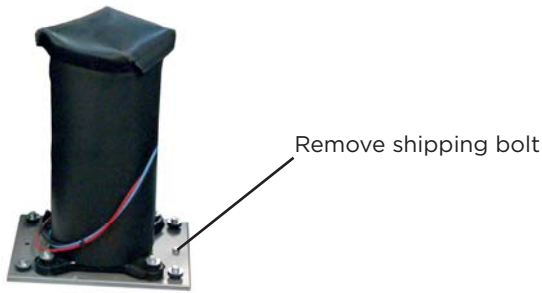
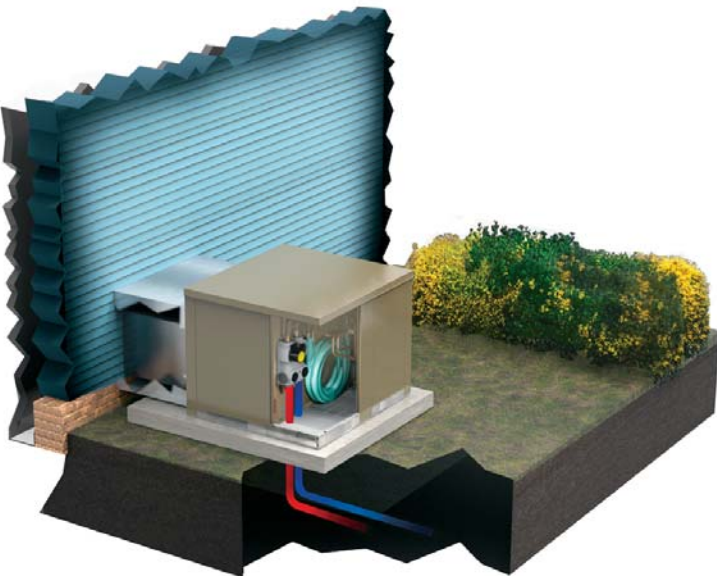

Figure 1: Slab Mounted Unit



Installing Roof (Curb) Mounted

Roof curb not provided by unit manufacturer and must be outsourced. Check building codes for weight distribution requirements (see operating weights table).

Follow all appropriate instructions to install the unit on a rooftop curb. See installation instructions provided with the roof curb and unit for more specific information.

Operating Weight

Model	LB/[KG]
026	502 [228]
038	545 [247]
049	580 [263]
064	596 [270]
072	606 [275]

Figure 2: Roof (Curb) Mounted Unit

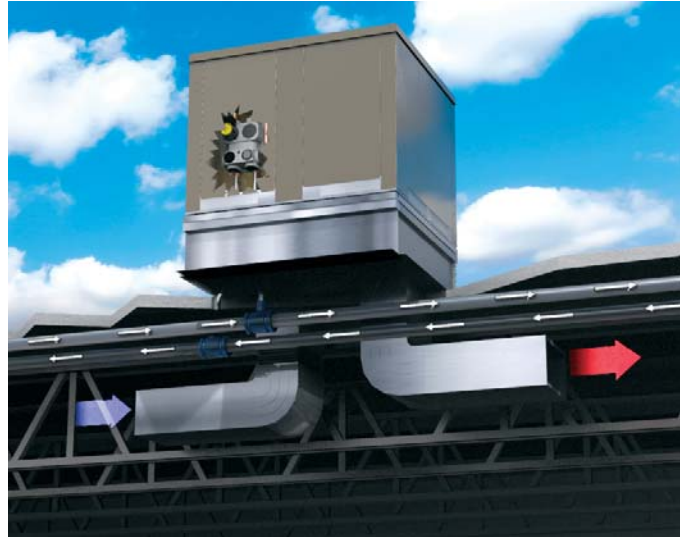

General Installation Information cont.

Duct System

Duct flanges are provided on side air discharge units to facilitate a duct connection. A flexible connector is recommended for discharge and return air duct connections on metal duct systems. Seal, insulate, and weatherproof all external ductwork. Seal, insulate and cover with a vapor barrier all ductwork passing through unconditioned spaces.

If the unit is to be connected to existing ductwork, check the duct system to ensure that it has the capacity to accommodate the air required for the unit application. If the duct is too small, as in the replacement of heating only systems, larger ductwork should be installed. All existing ductwork should be checked for leaks and repaired if necessary.

The duct system should be sized to handle the design airflow quietly and efficiently. To maximize sound attenuation of the unit blower, the supply and return plenums should include an internal duct liner of fiberglass or constructed of ductboard for the first few feet. On systems employing a sheet metal duct system, canvas connectors should be used between the unit and the ductwork. If air noise or excessive airflow is a problem, the blower speed can be changed.

Air Filter

Air filters are to be field installed either in the return air openings in the structure or in a filter rack before the unit. Unit should not be run without filters installed. The heat pump is not supplied with a filter rack.

NOTE: DO NOT OPERATE THE UNIT WITHOUT AN AIR FILTER.

Water Piping

The proper water flow must be provided to each unit whenever the unit operates. To assure proper flow, use pressure/temperature ports to determine the flow rate. Units with the flow center option have two P/T ports installed. Units with water valves do not come equipped with P/T ports and will have to be field installed. The ports should be located at the supply and return water connections on the unit. The proper flow rate cannot be accurately set without measuring the water pressure drop through the refrigerant-to-water heat exchanger. SCH80PVC, copper, flexible hose, or PE pipe are recommended for unit connections.

Never use flexible hoses smaller than 1-inch inside diameter on the unit. Limit hose length to 10 feet per connection. Check carefully for water leaks.

Water Quality

It is the responsibility of the system designer and installing contractor to ensure that acceptable water quality is present and that all applicable codes have been met in these installations. Failure to adhere to the guidelines in the water quality table could result in loss of warranty. In ground water situations where scaling could be heavy or where biological growth such as iron bacteria will be present, a closed loop system is recommended. The heat exchanger coils in ground water systems may, over a period of time, lose heat exchange capabilities due to a buildup of mineral deposits inside. These can be cleaned, but only by a qualified service mechanic, as special solutions and pumping equipment are required.

Heat pumps with cupronickel heat exchangers are recommended for open loop applications due to the increased resistance to build-up and corrosion, along with reduced wear caused by acid cleaning.

Water Treatment

Do not use untreated or improperly treated water. Equipment damage may occur. The use of improperly treated or untreated water in this equipment may result in scaling, erosion, corrosion, algae or slime. Purchase of a pre-mix antifreeze could significantly improve system reliability if the water quality is controlled and there are additives in the mixture to inhibit corrosion. There are many examples of such fluids on the market today such as Environol™ 1000 (pre-mix ethanol), and others. The services of a qualified water treatment specialist should be engaged to determine what treatment, if any, is required. The product warranty specifically excludes liability for corrosion, erosion or deterioration of equipment.

The heat exchangers and water lines in the units are copper or cupronickel tube. There may be other materials in the buildings piping system that the designer may need to take into consideration when deciding the parameters of the water quality. If antifreeze or water treatment solution is to be used, the designer should confirm it does not have a detrimental effect on the materials in the system.

General Installation Information cont.

Contaminated Water

In applications where the water quality cannot be held to prescribed limits, the use of a secondary or intermediate heat exchanger is recommended to separate the unit from the contaminated water. The table below outlines the water quality guidelines for unit heat exchangers. If these conditions are exceeded, a secondary heat exchanger is required. Failure to supply a secondary heat exchanger where needed will result in a warranty exclusion for primary heat exchanger corrosion or failure.

Low Water Coil Limit

Set the freeze sensing switch SW2-1 on the Aurora Base Control (ABC) printed circuit board for applications using a closed loop antifreeze solution to "LOOP" (15°F). On applications using an open loop/ground water system (or closed loop no antifreeze), set this dip switch to "WELL" (30°F), the factory default setting. (Refer to the DIP Switch Settings table in the Aurora Control section.)

Condensate Drain

To facilitate complete condensate removal, the outdoor package unit should be mounted level or slightly pitched towards drain. A PVC tube and coupler are provided with the unit. The coupler and tube need to be field installed to the drain pan using PVC primer and glue. An external trap is required (see figure 3) otherwise condensate will not drain during unit operation. If a vent is necessary, an open stand pipe may be applied to a tee in the field installed condensate piping. The vent must be installed on the outlet side of the condensate trap as shown in figure 3 or proper drainage will not occur. Mastic tape is provided to seal around the condensate opening.

Note: Do not operate the heat pump without a trap.

Figure 3: Condensate Drain Connection

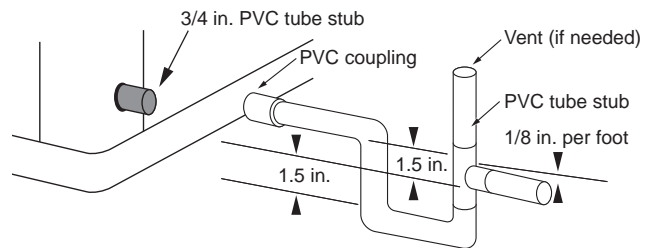

Material		Copper	90/10 Cupronickel	316 Stainless Steel
pH	Acidity/Alkalinity	7 - 9	7 - 9	7 - 9
Scaling	Calcium and Magnesium Carbonate	(Total Hardness) less than 350 ppm	(Total Hardness) less than 350 ppm	(Total Hardness) less than 350 ppm
Corrosion	Hydrogen Sulfide	Less than 0.5 ppm (rotten egg smell appears at 0.5 ppm)	10 - 50 ppm	Less than 1 ppm
	Sulfates	Less than 125 ppm	Less than 125 ppm	Less than 200 ppm
	Chlorine	Less than 0.5 ppm	Less than 0.5 ppm	Less than 0.5 ppm
	Chlorides	Less than 20 ppm	Less than 125 ppm	Less than 300 ppm
	Carbon Dioxide	Less than 50 ppm	10 - 50 ppm	10 - 50 ppm
	Ammonia	Less than 2 ppm	Less than 2 ppm	Less than 20 ppm
	Ammonia Chloride	Less than 0.5 ppm	Less than 0.5 ppm	Less than 0.5 ppm
	Ammonia Nitrate	Less than 0.5 ppm	Less than 0.5 ppm	Less than 0.5 ppm
	Ammonia Hydroxide	Less than 0.5 ppm	Less than 0.5 ppm	Less than 0.5 ppm
	Ammonia Sulfate	Less than 0.5 ppm	Less than 0.5 ppm	Less than 0.5 ppm
	Total Dissolved Solids (TDS)	Less than 1000 ppm	1000 - 1500 ppm	1000 - 1500 ppm
	LSI Index	+0.5 to -0.5	+0.5 to -0.5	+0.5 to -0.5
Iron Fouling (Biological Growth)	Iron, FE ²⁺ (Ferrous) Bacterial Iron Potential	< 0.2 ppm	< 0.2 ppm	< 0.2 ppm
	Iron Oxide	Less than 1 ppm, above this level deposition will occur	Less than 1 ppm, above this level deposition will occur	Less than 1 ppm, above this level deposition will occur
Erosion	Suspended Solids	Less than 10 ppm and filtered for max. of 600 micron size	Less than 10 ppm and filtered for max. of 600 micron size	Less than 10 ppm and filtered for max. of 600 micron size
	Threshold Velocity (Fresh Water)	< 6 ft/sec	< 6 ft/sec	< 6 ft/sec

NOTES: Grains = ppm divided by 17
mg/L is equivalent to ppm

2/22/12

Closed Loop Ground Source Systems



IMPORTANT: A secondary freeze detection thermostat is installed in the unit to automatically start loop circulator pump if the ambient temperature drops below 20°F. Loop freeze detection should also be maintained to the lowest temperature the insulated loop may encounter in the case of power failure.

NOTE: For closed loop systems with antifreeze protection, set SW2-1 to the “LOOP” (15°F) position. (Refer to the DIP Switch Settings table in the Aurora Control section.)

There are several options to attach the earth loop to the outdoor package unit, bottom connections with a flow center, side water connections, and bottom valve connection. The loop should be continued directly under the unit as shown in the Typical Outdoor Installations Using Closed Loop. Make the loop to bottom flow center connection with the supplied Geolink Fusion fittings for 1-1/4” PE pipe (Figure 4A). If the water connections are on the side of the unit the supply and return water fittings will be field installed 1” MPT fittings (Figure 4B). If the unit has the bottom water valve option the connection will be 1” hose. All PE pipe and hose should be insulated with a minimum of 1/2” closed cell foam from ground level to the unit connection. When mounting the unit to an existing concrete slab, holes must be bored through the slab to accommodate the 1-1/4” PE pipe with insulation. Ensure proper backfill to support the loop pipe and unit during settling. The loop pipe can also be installed at the back of the unit and ran thru the base pan structure to the loop circulators.

NOTE: Any loop pipe/hosing install outside the unit will need to be protected or damage may occur.

Once piping is completed between the unit, pumps and the ground loop, final purging and charging of the loop is required. A flush cart (or a 1.5 HP pump minimum) is needed to achieve adequate flow velocity in the loop to purge air and dirt particles from the loop itself. A filter **MUST** be used when flushing a loop. The standard 100 micron filter bag (LFC-F100M) is acceptable for capturing relatively large debris such as pipe shavings, gravel, and medium sand particles. In certain installation locations other smaller materials such as fine sand, silt, and clay can be less than 75 microns. For these smaller particles the use of the 1 micron filter bag is required (LFC-F1M). It is also recommended to run the flush cart with the 1 micron filter bag for at least 30 minutes. Antifreeze solution is used in most areas to prevent freezing. Flush the system adequately to remove as much air as possible then pressurize the loop to a static pressure of 40-50 psi (summer) or 50-75 psi (winter). This is normally adequate for good system operation. Loop static pressure will fluctuate with the seasons. Pressures will be higher in the winter months than during the cooling season. This fluctuation is normal and should be considered when initially charging the system.

After pressurization, be sure to turn the venting (burping) screw in the center of the pump two (2) turns open (water will drip out), wait until all air is purged from the pump, then tighten the plug. Ensure that the loop pumps provide adequate flow through the unit(s) by checking the pressure drop across the heat exchanger and comparing it to the Pressure Drop table in this catalog. 2.5 to 3 gpm of flow per ton of cooling capacity is recommended in earth loop applications.

Figure 4A: Bottom Closed Loop Ground Source Application

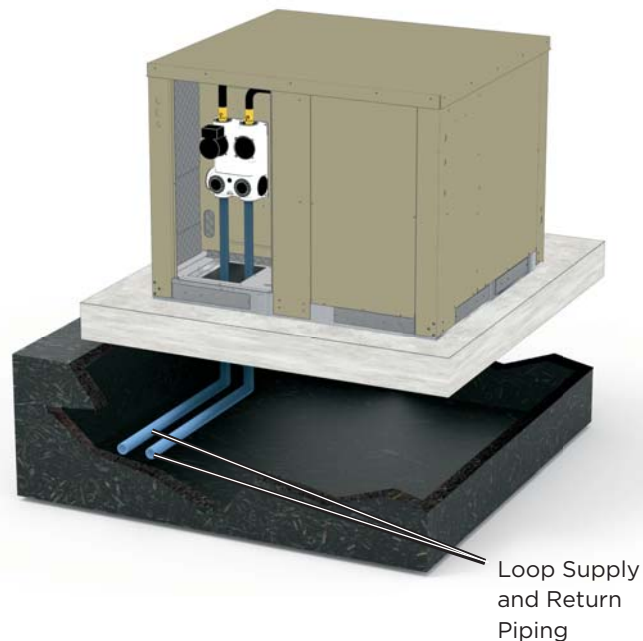

Figure 4B: Side Water Line Connections



NOTE: Additional information can be found in Flow Center installation manual and Flush Cart manual.

Closed Loop Ground Source Systems cont.

Multiple Units on One Flow Center

NOTE: This feature is only available in the Aurora Advanced Control package (AXB board), NOT the Aurora Base Control (ABC).

When two units are connected to one loop pumping system, pump control is automatically achieved by connecting the SL terminals on connector P2 in both units with 2-wire thermostat wire. These terminals are polarity dependant (see Figure 5b). The loop pump(s) may be powered from either unit, whichever is more convenient. If either unit calls, the loop pump(s) will automatically start. The use of two units on one flow center is generally limited to a total of 20 gpm capacity. It is recommended that water solenoid valves be installed on heat pumps that share a flow center. This is to allow water flow through only heat pump that has a demand. Circulating fluid through a heat exchanger of a system that is not operating could be detrimental to the long term reliability of the compressor.

NOTE: To achieve this same feature when heat pumps have only the Aurora Base Control, follow Figure 5a. Installer will be required to supply fuses, two relays, and wiring.

When equipment is ordered with factory installed internal flow center the flow center will be wired per Figure 6.

Figure 5a: Primary/Secondary Wiring with Aurora Base Control (no AXB Board)

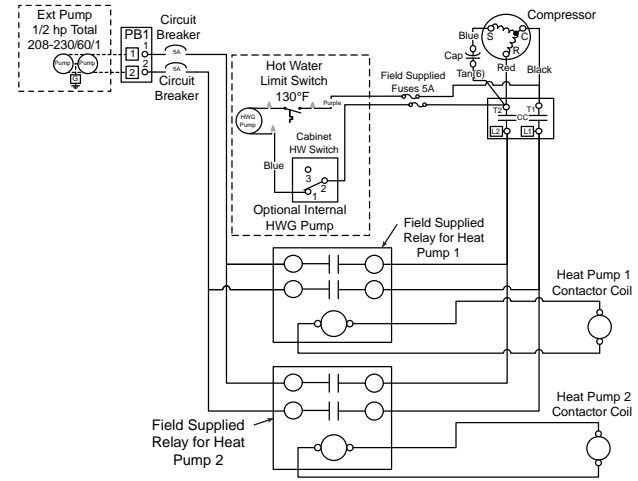

Figure 5b: Primary/Secondary Hook-up

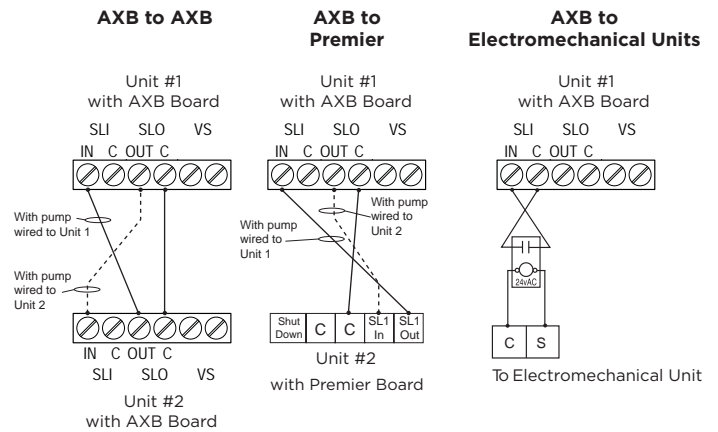
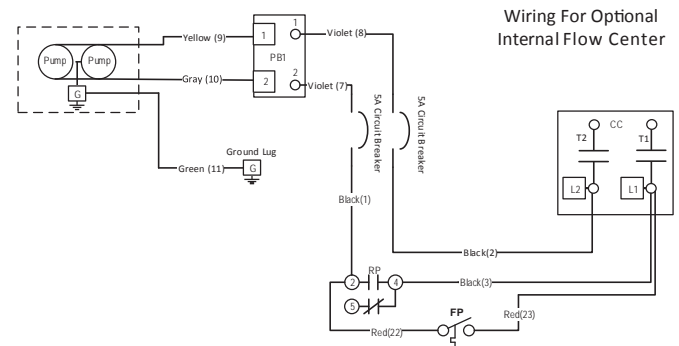

Figure 6: Loop Pump Wiring



Open Loop Ground Water Systems

Typical open loop piping is shown below. Always maintain water pressure in the heat exchanger by placing water control valves at the outlet of the unit to prevent mineral precipitation. Use a closed, bladder-type expansion tank to minimize mineral formation due to air exposure. Ensure proper water flow through the unit by checking pressure drop across the heat exchanger and comparing it to the figures in pressure drop table in this manual. 1.5-2 gpm of flow per ton of cooling capacity is recommended in open loop applications.

Discharge water from the unit is not contaminated in any manner and can be disposed of in various ways, depending on local codes, i.e. recharge well, storm sewer, drain field, adjacent stream or pond, etc. Most local codes forbid the use of sanitary sewer for disposal. Consult your local building and zoning departments to assure compliance in your area.

Figure 7: Open Loop Solenoid Valve Connection Option
Typical slow operating external 24V water solenoid valve (type V100FPT) wiring.

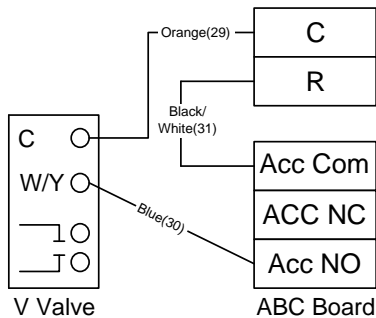

NOTE: SW2-4 should be “ON” and SW2-5 should be “OFF” when using a slow opening (V100FPT) water valve.

NOTE: For open loop/groundwater systems or systems that do not contain an antifreeze solution, set SW2-Switch #1 to the “WELL” (30°F) position. (Refer to the DIP Switch Settings table in the Aurora Control section.) Slow opening/closing solenoid valves (type V100FPT) are recommended to eliminate water hammer.

When equipment is ordered with factory installed ON/OFF water valve the slow operating water valve will be wired per Figure 7. DIP SW2-4 (ON) and SW2-5 (OFF) will be configured so as to delay compressor and blower ON for 90 seconds to allow sufficient time for valve opening.

Figure 8: Open System - Groundwater Application

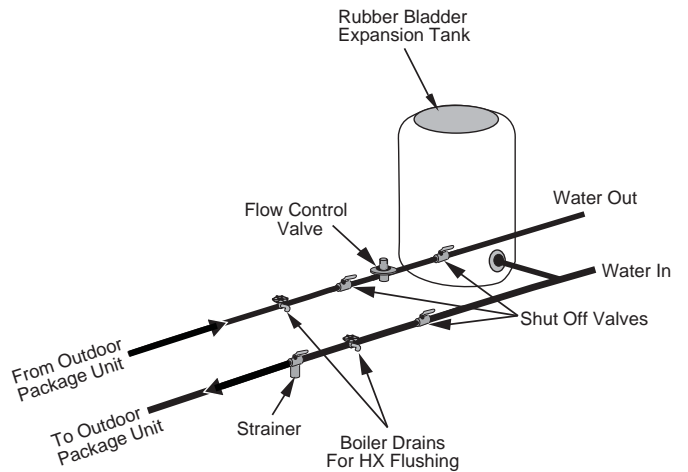

Electrical Connections

General

The heat pump, and if auxiliary heat is installed, must have a separate electrical service with a field-supplied, waterproof disconnect switch mounted at, or within sight of the heat pump.

Be sure the available power is the same voltage and phase as that shown on the unit serial plate. Line and low voltage wiring must be done in accordance with local codes or the National Electric Code, whichever is applicable.

Unit Power Connection

Connect the incoming line voltage wires to L1 and L2 of the contactor as shown in Figure 9B for single-phase unit. Consult the Unit Electrical Data in this manual for correct fuse sizes.

Open the front access panel. Insert power wires through knockouts in cabinet. Route wires through left side of control box and connect to contactor and ground (Figure 9A).

Accessory Relay

A set of “dry” contacts has been provided to control accessory devices, such as water solenoid valves on open loop installations, electronic air cleaners, humidifiers, etc. This relay contact should be used only with 24 volt signals and not line voltage power. The relay has both normally open and normally closed contacts and can operate with either the fan or the compressor. Use DIP switch SW2-4 and 5 to cycle the relay with blower, compressor, or control a slow opening water valve. The relay contacts are available on terminals #1 and #3 for normally closed, and #2 and #3 for normally open on P2.

A second configurable accessory relay is provided on the AXB board, if installed. When powering high VA draw components such as electronic air cleaners or V type open loop water valves, R should be taken ‘pre-fuse’ from the ‘R’ quick connect on the ABC board and not the ‘post-fuse’ ‘R’ terminal on the thermostat connection. If not, blown ABC fuses might result.

208 Volt Operation

All 208/230 units are factory wired for 230 volt operation. For 208 volt operation, the red and blue transformer wires must be switched on terminal strip PS.

Figure 9A:
Wire access (control box closed)

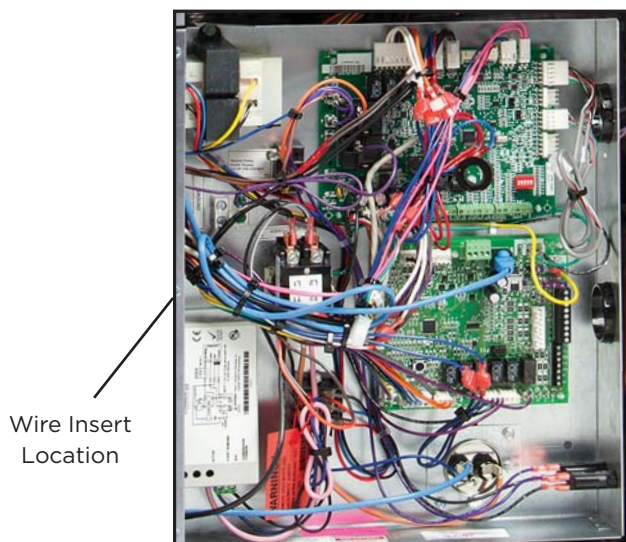
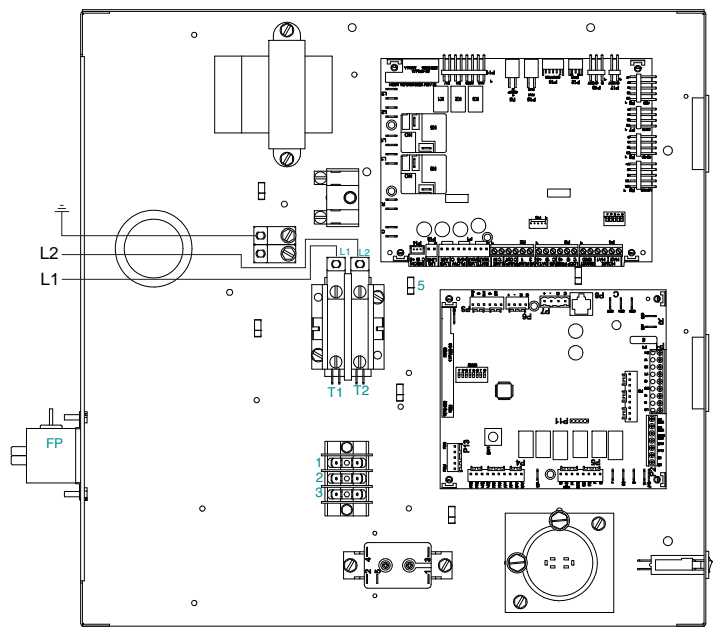

Figure 9B:
Line Voltage 208-230/60/1 control box



Electronic Thermostat Installation

Position the thermostat subbase against the wall so that it is level and the thermostat wires protrude through the middle of the subbase. Mark the position of the subbase mounting holes and drill holes with a 3/16-inch bit. Install supplied anchors and secure base to the wall. Thermostat wire must be 8-conductor (4 or 5 conductor for communicating thermostats), 20-AWG (minimum) wire. Strip the wires back 1/4-inch (longer strip lengths may cause shorts) and insert the thermostat wires into the connector as shown. Tighten the screws to ensure secure connections. The thermostat has the same type connectors, requiring the same wiring. See instructions enclosed in the thermostat for detailed installation and operation information. The W1 terminal on TPCM32U03A* and TPCM32U04A* communicating thermostats may be hard wired to provide aux/emergency heat in the event communication is lost between the thermostat and the ABC microprocessor.

NOTE: Aurora Base Control (ABC) DIP switch SW2-7 is required to be in the “OFF” position for the control to operate with FaultFlash or ComforTalk thermostats. SW2-7 in the “ON” position configures the control to operate with typical thermostats (continuous lockout signal). There must be a wire connecting Y2 on the Aurora controller to 2nd stage compressor on the thermostat for proper operation. SW2-7 DIP switch position is not relevant with communicating thermostats.

Figure 10: Thermostat Wiring (Y1 Style Signals)

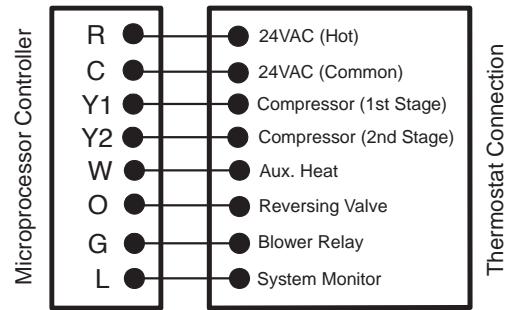
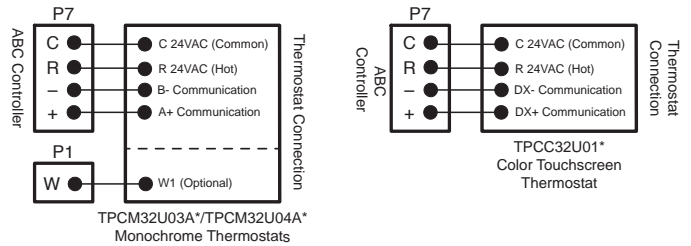

Figure 11: Thermostat Wiring (Communicating Style Signals)



Auxiliary Heat Ratings

Model	KW		Stages	BTU/HR		Min CFM	Model Size Compatibility		
	208V	230V		208V	230V		026	036 - 042	049 - 072
EAM5*	3.6	4.8	1	12,300	16,300	450	●		
EAM8*	5.7	7.6	2	19,400	25,900	550	●		
EAM10*	7.2	9.6	2	24,600	32,700	650	●		
EAL10*	7.2	9.6	2	24,600	32,700	1100		●	●
EAL15*	10.8	14.4	2	36,900	49,100	1250		●	●
EAL20*	14.4	19.2	2	49,200	65,500	1500			●

7/9/2017

Air flow level for auxiliary heat (Aux) must be equal to or above the minimum CFM in this table

Auxiliary Heat Electrical Data

Model	Supply Circuit	Heater Amps		Min Circuit Amp		Fuse (USA)		Fuse (CAN)		CKT BRK	
		208 V	240 V	208 V	240 V	208 V	240 V	208 V	240 V	208 V	240 V
EAM5*	Single	17.3	20.0	26.7	30.0	30	30	30	30	30	30
EAM8*	Single	27.5	31.7	39.3	44.6	40	45	40	45	40	45
EAM10*	Single	34.7	40.0	48.3	55.0	50	60	50	60	50	60
EAL10*	Single	34.7	40.0	53.3	60.0	60	60	60	60	60	60
EAL15*	Single	52.0	60.0	75.0	85.0	80	90	80	90	70	100
	L1/L2	34.7	40.0	53.3	60.0	60	60	60	60	60	60
	L3/L4	17.3	20.0	21.7	25.0	25	25	25	25	20	30
EAL20*	Single	69.3	80.0	96.7	110.0	100	110	100	110	100	100
	L1/L2	34.7	40.0	53.3	60.0	60	60	60	60	60	60
	L3/L4	34.7	40.0	43.3	50.0	45	50	45	50	40	50

All heaters rated single phase 60 cycle and include unit fan load

7/9/2017

All fuses type "D" time delay (or HACR circuit breaker in USA)

Supply wire size to be determined by local codes

Electrical Data

Dual Capacity Unit with Variable Speed ECM Motor

Model	Rated Voltage	Voltage Min/Max	Compressor				Ext Loop FLA	Blower Motor FLA	Total Unit FLA	Min Circ Amp	Max Fuse/HACR
			MCC	RLA	LRA	LRA**					
026	208-230/60/1	187/253	18.2	11.6	58.3	21.0	5.4	4.0	21.0	24.0	35
038	208-230/60/1	187/253	23.8	15.2	83.0	30.0	5.4	4.0	24.6	28.4	40
038*	208-230/60/1	187/253	23.8	15.2	83.0	30.0	5.4	7.0	27.6	31.4	50
049	208-230/60/1	187/253	33.0	21.1	104.0	37.0	5.4	7.0	33.5	38.8	60
064	208-230/60/1	187/253	42.3	27.1	152.9	54.0	5.4	7.0	39.5	46.2	70
072	208-230/60/1	187/253	46.3	29.6	179.2	63.0	5.4	7.0	42.0	49.4	70

*With optional 1 HP Variable Speed ECM motor

7/10/17

**With optional IntelliStart

Rated Voltage of 208/230/60/1

HACR circuit breaker in USA only

All fuses Class RK-5

Blower Performance Data

Dual Capacity ECM Blower Table without Zoning

MODEL	MAX ESP	AIR FLOW SPEED SETTINGS											
		1	2	3	4	5	6	7	8	9	10	11	12
026	0.50		400	475 G	625	725 L	775	850 H	950	1050	1175 Aux		
038	0.50	650	700 G	825	950	1075 L	1175	1275 H	1375	1450	1500 Aux		
038 W/1HP*	0.75	675	850 G	1025 L	1250 H	1425	1625	1750	1925	2075 Aux	2225		
049	0.75	675	850 G	1000	1200	1400 L	1600 H	1750	1900	2100	2150 Aux		
064	0.75	700	875 G	1025	1225	1425	1625 L	1775	1925 H	2125	2175 Aux		
072	0.75	700	875 G	1025 G	1225	1425	1625	1775 L	1925	2125 H	2175 Aux		

Factory settings are at recommended G-L-H-Aux speed settings

L-H settings MUST be located within boldface CFM range

"Aux" is factory setting for auxiliary heat and must be equal to or above the "H" setting as well as at least the minimum required for the auxiliary heat package

"G" may be located anywhere within the airflow table

CFM is controlled within +/-5% up to the maximum ESP

Max ESP includes allowance for wet coil

7/24/17

Dual Capacity ECM Blower Table with IntelliZone2

MODEL	MAX ESP	AIR FLOW SPEED SETTINGS											
		1	2	3	4	5	6	7	8	9	10	11	12
026	0.50		400 G	475	625 L 55%	725 70%	775 85%	850 H 100%	950	1050	1175 Aux		
038	0.50	650	700 G	825 L 55%	950 70%	1075	1175 85%	1275 H 100%	1375	1450	1500 Aux		
038 W/1HP*	0.75	675 G	850 L 55%	1025 70%	1250 85%	1425 H 100%	1625	1750	1925	2075 Aux	2225		
049	0.75	675	850 G	1000 L 55%	1200 70%	1400 85%	1600 H 100%	1750	1900	2100	2150 Aux		
064	0.75	700	875 G	1025	1225 L 55%	1425 70%	1625	1775 85%	1925 H 100%	2125	2175 Aux		
072	0.75	700	875	1025 G	1225	1425 L 55%	1625 70%	1775	1925 85%	2125 H 100%	2175 Aux		

Factory settings are at recommended G-L-H-Aux speed settings

L-H settings MUST be located within boldface CFM range

"Aux" is factory setting for auxiliary heat and must be equal to or above the "H" setting as well as at least the minimum required for the auxiliary heat package

"G" may be located anywhere within the airflow table

CFM is controlled within +/-5% up to the maximum ESP

Max ESP includes allowance for wet coil

9/18/17

Dual Capacity ECM Blower Table with IntelliZone2•24V

MODEL	MAX ESP	AIR FLOW SPEED SETTINGS											
		1	2	3	4	5	6	7	8	9	10	11	12
026	0.50		400	475 G	625	725 L	775	850 H	950	1050	1175 Aux		
038	0.50	650	700 G	825	950	1075 L	1175	1275 H	1375	1450	1500 Aux		
038 W/1HP*	0.75	675	850 G	1025 L	1250 H	1425	1625	1750	1925	2075 Aux	2225		
049	0.75	675	850 G	1000	1200	1400 L	1600 H	1750	1900	2100	2150 Aux		
064	0.75	700	875 G	1025	1225	1425	1625 L	1775	1925 H	2125	2175 Aux		
072	0.75	700	875	1025 G	1225	1425	1625	1775 L	1925	2125 H	2175 Aux		

Factory settings are at recommended G-L-H-Aux speed settings

L-H settings MUST be located within boldface CFM range or higher

"Aux" is factory setting for auxiliary heat and must be equal to or above the "H" setting as well as at least the minimum required for the auxiliary heat package

"G" may be located anywhere within the airflow table

CFM is controlled within +/-5% up to the maximum ESP

Max ESP includes allowance for wet coil

7/24/17

Blower Performance Data cont.

Setting Blower Speed - Variable Speed ECM

The ABC board's Yellow Config LED will flash the current ECM blower speed selections for "G", low, and high continuously with a short pause in between. The speeds can also be confirmed with the AID Tool under the Setup/ECM Setup screen. The Aux will not be flashed but can be viewed in the AID Tool. The ECM blower motor speeds can be field adjusted with or without using an AID Tool.

ECM Setup without an AID Tool

The blower speeds for "G", Low (Y1), High (Y2), and Aux can be adjusted directly at the Aurora ABC board which utilizes the push button (SW1) on the ABC board. This procedure is outlined in the ECM Configuration Mode portion of the Aurora 'Base' Control System section. The Aux cannot be set manually without an AID Tool.

ECM Setup with an AID Tool

A much easier method utilizes the AID Tool to change the airflow using the procedure below. First navigate to the Setup screen and then select ECM Setup. This screen displays the current ECM settings. It allows the technician to enter the setup screens to change the ECM settings. Change the highlighted item using the ◀ and ▶ buttons and then press the ◻ button to select the item.

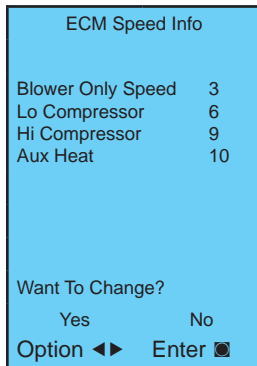

Selecting YES will enter ECM speed setup, while selecting NO will return to the previous screen.

ECM Speed Setup - These screens allow the technician to select the "G", low, high, and auxiliary heat blower speed for the ECM blower motor. Change the highlighted item using the ▲ and ▼ buttons. Press the ◻ button to select the speed.

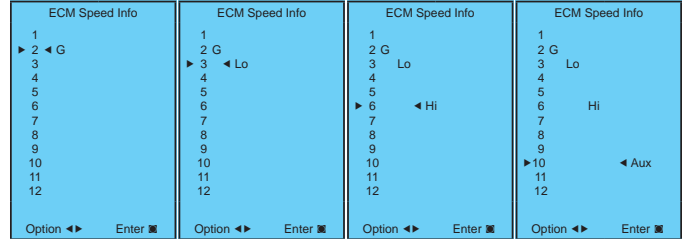

After the auxiliary heat speed setting is selected the AID Tool will automatically transfer back to the ECM Setup screen.

Cooling Airflow Setup - These screens allow the technician to select -15%, -10%, -5%, None or +5%. Change the adjustment percentage using the ▲ and ▼ buttons. Press the ◻ button to save the change.

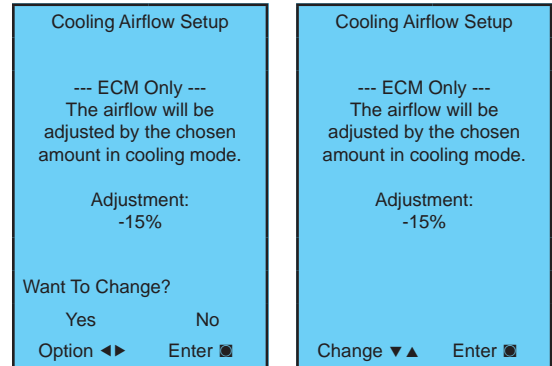

Dimensional Data

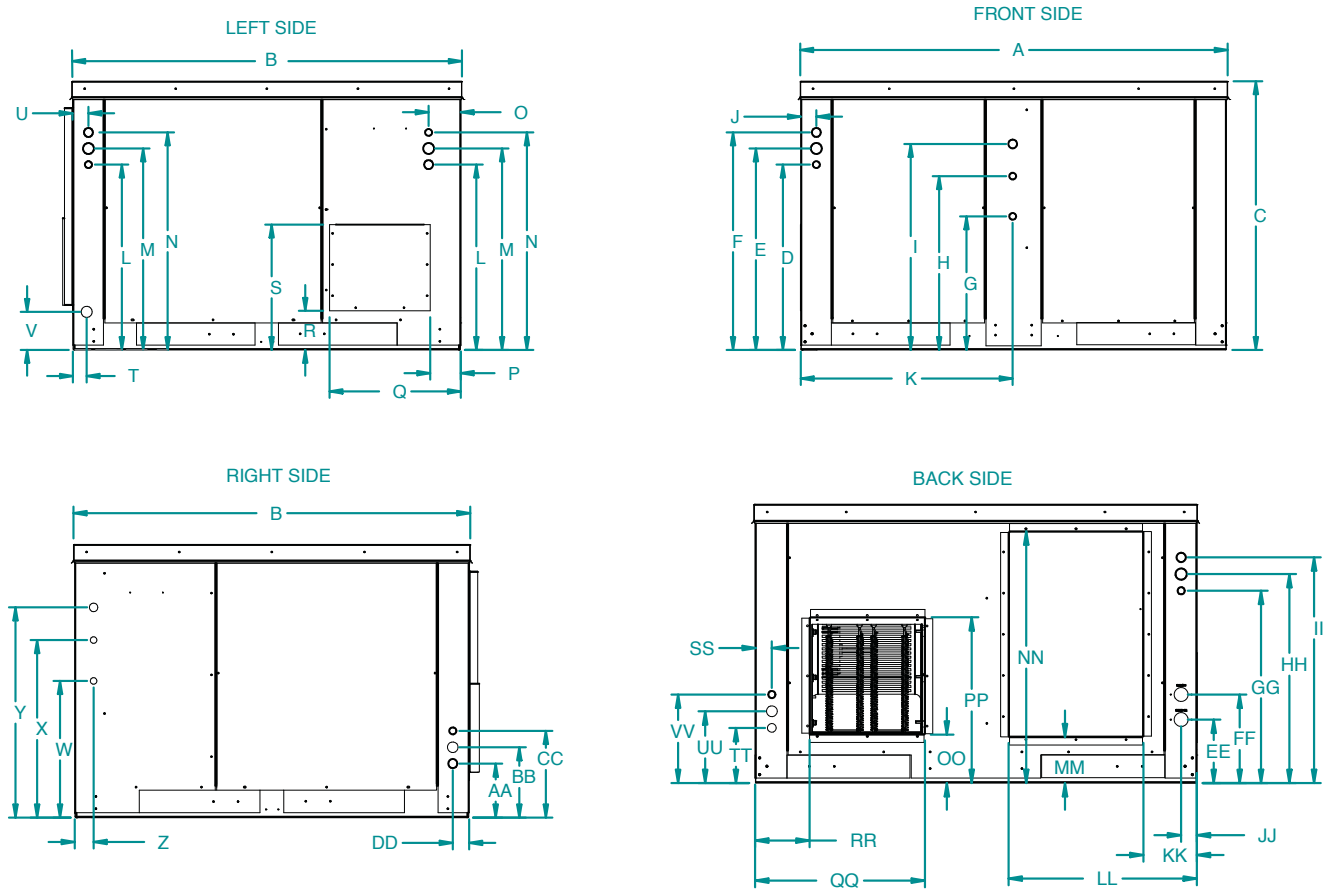

Side Discharge Configuraton	Overall Cabinet			Front Electrical Knockouts								Left Electrical Knockouts											
	A	B	C	D	E	F	G	H	I	J	K	L	M	N	O	P	Q	R	S	T	U	V	
	Width	Depth	Height	7/8"	1-3/8"	1-1/8"	7/8"	7/8"	1-1/8"	N/A	N/A	7/8"	1-3/8"	1-1/8"	N/A	Pump			N/A	N/A	Condensate		
026	in.	53.1	48.5	33.3	23.0	25.0	27.0	16.6	21.6	25.6	1.9	26.4	23.4	25.4	27.4	4.0	3.8	16.3	4.9	15.6	1.7	2.0	4.7
	cm.	134.9	123.2	84.6	58.4	63.5	68.6	42.2	54.9	65.0	4.8	67.1	59.4	64.5	69.6	10.2	9.7	41.4	12.4	39.6	4.3	5.1	11.9
038	in.	53.1	48.5	33.3	23.0	25.0	27.0	16.6	21.6	25.6	1.9	26.4	23.4	25.4	27.4	4.0	3.8	16.3	4.9	15.6	1.7	2.0	4.7
	cm.	134.9	123.2	84.6	58.4	63.5	68.6	42.2	54.9	65.0	4.8	67.1	59.4	64.5	69.6	10.2	9.7	41.4	12.4	39.6	4.3	5.1	11.9
049-072	in.	53.1	48.5	41.3	30.9	32.9	34.9	24.5	29.5	33.5	2.0	26.4	30.9	32.9	34.9	1.9	3.8	16.3	8.9	19.6	1.5	2.0	4.9
	cm.	134.9	123.2	104.9	78.5	83.6	88.6	62.2	74.9	85.1	5.1	67.1	78.5	83.6	88.6	4.8	9.7	41.4	22.6	49.8	3.8	5.1	11.9

Side Discharge Configuraton	Right Side Electrical Knockouts								Back Side Electrical Knockouts																		
	W	X	Y	Z	AA	BB	CC	DD	EE	FF	GG	HH	II	JJ	KK	LL	MM	NN	OO	PP	QQ	RR	SS	TT	UU	VV	
	7/8"	7/8"	1-1/8"	N/A	1-1/8"	1-3/8"	7/8"	N/A	WTR OUT	WTR IN	7/8"	1-3/8"	1-1/8"	N/A	Return			Discharge			N/A	1-1/8"	1-3/8"	7/8"			
026	in.	16.7	21.7	25.7	2.3	6.6	8.6	10.6	2.0	7.6	10.6	23.0	25.3	27.0	1.9	6.4	22.5	5.5	30.2	5.5	16.5	18.2	8.7	2.0	6.6	8.6	10.6
	cm.	42.4	55.1	65.3	5.8	16.8	21.8	26.9	5.1	19.3	26.9	58.4	64.3	68.6	4.8	16.3	57.2	14.0	76.7	14.0	41.9	46.2	22.1	5.1	16.8	21.8	26.9
038	in.	16.7	21.7	25.7	2.3	6.6	8.6	10.6	2.0	7.6	10.6	23.0	25.3	27.0	1.9	6.4	22.5	5.5	30.2	5.8	19.8	20.4	6.7	2.0	6.6	8.6	10.6
	cm.	42.4	55.1	65.3	5.8	16.8	21.8	26.9	5.1	19.3	26.9	58.4	64.3	68.6	4.8	16.3	57.2	14.0	76.7	14.7	50.3	51.8	17.0	5.1	16.8	21.8	26.9
049-072	in.	24.6	29.6	33.6	2.3	6.6	8.6	10.6	2.0	7.6	10.6	30.9	32.9	34.9	1.9	6.4	22.5	9.3	34.1	5.5	19.1	20.1	6.7	2.0	6.6	8.6	10.6
	cm.	62.5	75.2	85.3	5.8	16.8	21.8	26.9	5.1	19.3	26.9	78.5	83.6	88.6	4.8	16.3	57.2	23.6	86.6	14.0	48.5	51.1	17.0	5.1	16.8	21.8	26.9

Discharge/Return flanges are field installed and extend 1" (25.4 mm) from cabinet
 Fractional dimensions indicate knockout sizes.

Dimensional Data cont.

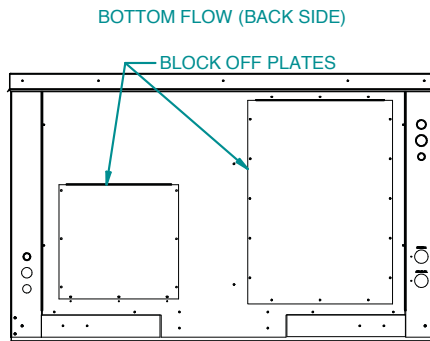
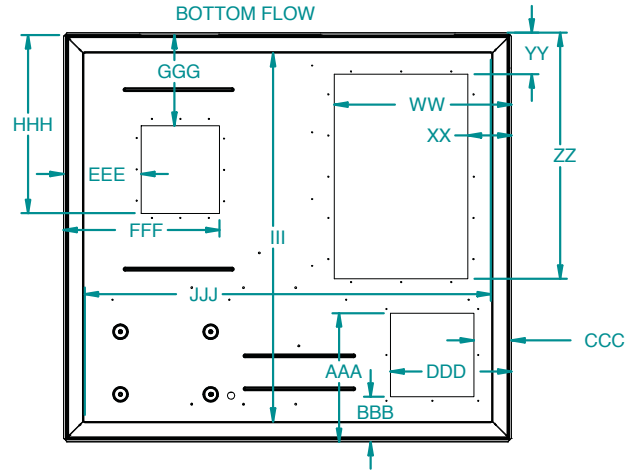

Bottom Flow Configuraton	Bottom Side Features														
	WW	XX	YY	ZZ	AAA	BBB	CCC	DDD	EEE	FFF	GGG	HHH	III	JJJ	
	Return				Loop				Discharge						
026	in.	21.3	5.3	5.0	29.5	15.4	5.4	4.5	14.5	9.3	18.7	10.9	21.3	44.2	48.8
	cm.	54.1	13.5	12.7	74.9	39.1	13.7	11.4	36.8	23.6	47.5	27.7	54.1	112.3	124.0
038	in.	21.3	5.3	5.0	29.5	15.4	5.4	4.5	14.5	7.2	20.4	12.3	25.7	44.2	48.8
	cm.	54.1	13.5	12.7	74.9	39.1	13.7	11.4	36.8	18.3	51.8	31.2	65.3	112.3	124.0
049-072	in.	21.3	5.3	5.0	29.5	15.4	5.4	4.5	14.5	7.2	20.4	12.3	25.7	44.2	48.8
	cm.	54.1	13.5	12.7	74.9	39.1	13.7	11.4	36.8	18.3	51.8	31.2	65.3	112.3	124.0

Dimensional Data cont.

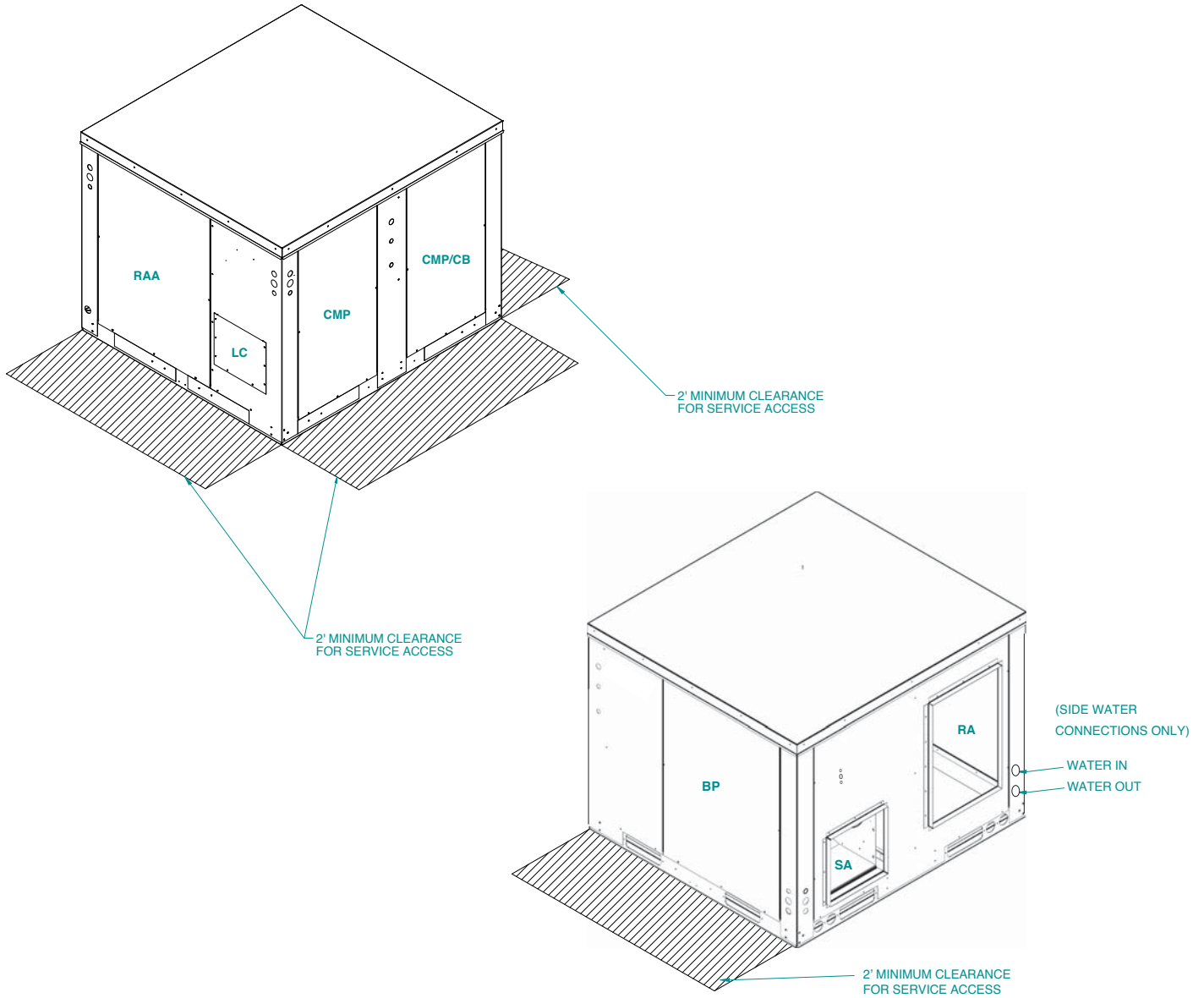

Legend	
RA	Return Air
RAA	Return Air Access
SA	Supply Air
CB	Control Access Panel
CMP	Compressor Access Panel
BP	Blower Access Panel
LC	Loop Connection Access

Physical Data

Model	DUAL CAPACITY					
	026	038	049	064	072	
Compressor (1 each)	Copeland UltraTech, Dual Capacity Scroll					
Factory Charge R410a, oz [kg] (Aluminum tube and fin air coil)	52 [1.47]	78 [2.21]	92 [2.61]	96 [2.72]	110 [3.12]	
ECM Blower Motor & Blower						
Blower Motor Type/Speeds	VS ECM	Variable Speed ECM				
Blower Motor- hp [W]	VS ECM	1/2 [373]	1/2 [373]	1 [746]	1 [746]	1 [746]
High Static Blower Motor - hp [W]	VS ECM	n/a	1 [746]	n/a	n/a	n/a
Blower Wheel Size (Dia x W), in. [mm]	VS ECM	9 x 7 [229 x 178]	11 x 10 [279 x 254]	11 x 10 [279 x 254]	11 x 10 [279 x 254]	11 x 10 [279 x 254]
High Static Blower Wheel Size - [Dia. x W], in. [mm]	VS ECM	n/a	11 x 10 [279 x 254]	n/a	n/a	n/a
Coax and Water Piping						
Water Connections Size (Side) - FPT - in [mm]	1" [25.4]	1" [25.4]	1" [25.4]	1" [25.4]	1" [25.4]	
Water Connections Size (Flow Center Bottom)	GeoLink Double O-ring Fitting					
Water Connections Size (Water Valve Bottom)	1" Hose					
Coax & Piping Water Volume - gal [l]	0.7 [2.6]	1.3 [4.9]	1.6 [6.1]	1.6 [6.1]	2.3 [8.7]	
Vertical						
Air Coil Dimensions (H x W), in. [mm]	24 x 20 [610 x 542]	28 x 25 [711 x 635]	32 x 25 [813 x 635]	36 x 25 [914 x 635]	36 x 25 [914 x 635]	
Air Coil Total Face Area, ft2 [m2]	3.3 [0.310]	4.9 [0.451]	5.6 [0.570]	6.3 [0.641]	6.3 [0.641]	
Air Coil Tube Size, in [mm]	3/8 [9.5]	3/8 [9.5]	3/8 [9.5]	3/8 [9.5]	3/8 [9.5]	
Air Coil Number of rows	3	3	3	4	4	
Weight - Operating, lb [kg]	502 [228]	545 [247]	580 [263]	596 [270]	606 [275]	
Weight - Packaged, lb [kg]	532 [241]	575 [261]	610 [277]	626 [284]	636 [289]	

8/7/2017

The Aurora™ Control System

Aurora ‘Base’ Control

The Aurora ‘Base’ Control (ABC) System is a complete residential and commercial comfort system that brings all aspects of the HVAC system into one cohesive module network. The ABC features microprocessor control and HP, LP, condensate and freeze detection, over/under voltage faults, along with communicating thermostat capability for complete fault detection text at the thermostat.



Aurora uses the Modbus communication protocol to communicate between modules. Each module contains the logic to control all features that are connected to the module. The Aurora ‘Base’ Control (ABC) has two Modbus channels. The first channel is configured as a master for connecting to devices such as a communicating thermostat, expansion board, or other slave devices. The second channel is configured as a slave for connecting the Aurora Interface Diagnostics Tool (AID Tool).

Aurora ‘Advanced’ Control

The Aurora ‘Advanced’ Control expands on the capability of the Aurora ‘Base’ Control (ABC) System by adding the Aurora Expansion Board (AXB). The additional features include compressor current monitoring, loop pump linking, and also allows for optional energy, refrigeration, and performance monitoring factory installed add-on sensor kits. The AXB also features a second field configurable accessory relay, and two home automation inputs that are AID configurable for different types of alarms from sump pumps to home security. The Smart Grid input is AID configurable with many options to react to Utility controlled relay operation for ON Peak optimization. The AXB also expands the communication capability for IntelliZone2 ready operation as well as other expansion with the ClimateTalk protocol.

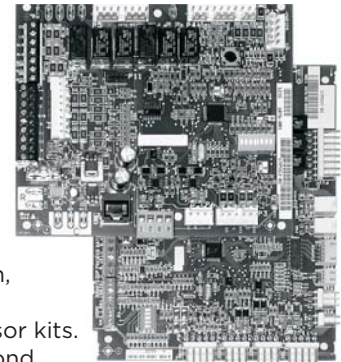





Aurora Control Features	Description	Aurora ‘Base’	Aurora ‘Advanced’
Microprocessor Compressor Control	Microprocessor control of compressor for timings with FP1, HP, LP, Condensate, assignable Acc relay	•	•
Advanced Microprocessor Features	Smart Grid, Home Automation Alarm Inputs, and Accessory2 Relay (HRV/ERV)	-	•
Base Loop Pump Control	Compressor Contactor powers Loop Pump with inline circuit breaker and no loop pump linking capability.	•	See below
Compressor Monitoring	Control monitors compressor starts for high current, missing leg etc.	-	•
Smart Grid/Utility Input	Allows simple input to externally enable of occupied/unoccupied mode for basic utility time of use programs.	-	Dry Contact x1
Home Automation Alarm Input	Allows simple input to signal sump, security, or smoke/CO sensor alarms from other home automation or security systems. The two inputs can be field configured to a number of options and logic.	-	Dry Contactx2
HAN/Smart Grid Com (AWL and Portal) Kit (If available)	Allows direct communication of the Aurora to Smart Meters, Home Automation Network and Internet.	-	Optional AWL (if available)
IntelliZone2® Compatibility	IntelliZone2 communicates Modbus to the heat pump via the AXB board.	With Optional AXB Kit and IntelliZone2	Optional IntelliZone2
IntelliZone2 • 24V Compatibility	Communicates to the heat pump via 24VAC (AXB not required)	•	-

The Aurora Control System cont.

Service Device	Description	Aurora 'Base'	Aurora 'Advanced'
 <p>Aurora Interface and Diagnostics (AID) Tool</p>	<p>Allows setup, monitoring and troubleshooting of any Aurora Control.</p> <p>NOTE: Although the ABC has basic compatibility with all Aurora, new product features may not be available on older AID Tools. To simplify the basic compatibility ensure the version of AID is at least the same or greater than the ABC software version.</p>	For Service (Ver. 1.xx or greater)	For Service (Ver. 2.xx or greater)

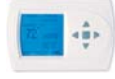
Add On Control Feature Kits (field or factory installed)	Description	Aurora 'Base'	Aurora 'Advanced'
Geo Energy Monitoring Kit	Monitors realtime power consumption of compressor, blower, aux heat and pump. Requires thermostat TPCM32UO3*, TPCM32UO4*, or TPCC32UO1*. AXB required.	-	Standard
Refrigeration Monitoring Kit	Monitors realtime pressures, temperatures, superheat, and subcooling. AXB required.	-	Optional Sensor Kit
Performance Monitoring Kit	Monitors air and water temperatures, and water flow rate and calculates heat of extraction/rejection. AXB required.	-	Optional Sensor Kit
Data Logging (AWL) Kit (if available)	Allows data logging of up to 12 months. AXB required. Can also be temporarily installed.	-	Optional
HAN/Smart Grid Com (AWL and Portal) Kit (If Available)	Allows direct communication of the Aurora to Smart Meters, HAN, and internet. AXB required.	-	Optional
AXB Kit for flow center linking, IntelliZone2	Added for key features of IntelliZone2 communication, Energy, Refrigeration, and Performance monitoring.	Optional (Field Kit)	Standard

Add On Thermostats and Zoning	Description	Aurora 'Base'	Aurora Advanced
 <p>TP32U03*/04* - MonoChrome Traditional Y1, Y2 Thermostat</p>	Elite Stat with full English fault codes and alerts, traditional Y1, Y2 thermostat. Not compatible with AWL (if available).	Optional	Optional
 <p>TP32S01*/02* - Traditional Y1, Y2 Thermostat</p>	Traditional Y1, Y2 thermostat. Not compatible with AWL (if available).	Optional	Optional
 <p>TPCM32U03A*/04A* - MonoChrome Communicating Thermostat</p>	Elite Stat with full English fault codes and alerts, communicating thermostat. Monochrome thermostat allows instantaneous energy measurement only. Compatible with AWL (if available).	Optional	Optional
 <p>TPCC32U01* - Color Touchscreen Communicating Thermostat</p>	4.3 in. color touchscreen communicating thermostat with full English fault codes and alerts. Color thermostat allows instantaneous energy measurement and 13 month energy usage history. Compatible with AWL (if available).	Optional	Optional
IntelliZone2 •24V Zoning Compatibility	IntelliZone2 •24V is a non-communicating zoning system requiring Y1, Y2 signals that controls up to 4 zones (dual capacity). For heat pumps without the optional AXB board.	-	Optional (IntelliZone2 Preferred)
 <p>IntelliZone2® Zoning</p>	IntelliZone2® is a communicating zoning system that includes color main thermostat and up to 6 zones (with variable speed, 4 zones (with dual capacity)). There are multiple thermostat options (MasterStat, TPCC32U01*, SensorStat, ZoneStat, SensorStat-Remote). Compatible with AWL (if available).	-	Optional (IntelliZone2 Preferred)

The Aurora ‘Base’ Control System cont.

Aurora ‘Base’ Control

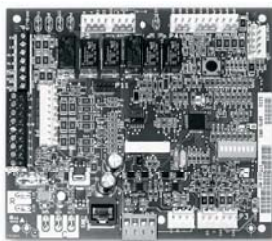

NOTE: Refer to the Aurora Base Control Application and Troubleshooting Guide and the Instruction Guide: Aurora Interface and Diagnostics (AID) Tool for additional information.

Control Features

Variable Speed ECM Blower Motor Option

A Variable Speed ECM blower motor can be driven directly using the onboard PWM output. Four blower speeds are available based upon the G, Y1, Y2, and W input signals to the board. The blower speeds can be changed either by the ECM manual configurations mode method or by using the Aurora AID Tool directly. All four blower speeds can be set to the same speed if desired.

Other Control Features

- Random start at power up
- Anti-short cycle protection
- High and low pressure cutouts
- Loss of charge
- Water coil freeze detection
- Air coil freeze detection
- Over/under voltage protection
- Condensate overflow sensor
- Load shed
- Dehumidification (where applicable)
- Emergency shutdown
- Hot gas reheat operation (where applicable)
- Diagnostic LED
- Test mode push button switch
- Two auxiliary electric heat outputs
- Alarm output
- Accessory output with N.O. and N.C.
- Two Modbus communication ports

Field Selectable Options via Hardware

DIP Switch (SW1) – Test/Configuration Button (See SW1 Operation Table)

Test Mode

The control is placed in the test mode by holding the push button switch SW1 for 2 - 5 seconds. In test mode most of the control timings will be shortened by a factor of sixteen (16). LED3 (green) will flash at 1 second on and 1 second off. Additionally, when entering test mode LED1 (red) will flash the last lockout one time. Test mode will automatically time out after 30 minutes. Test mode can be exited by pressing and holding the SW1 button for 2 to 5 seconds or by cycling the power. **NOTE:** Test mode will automatically be exited after 30 minutes.

Variable Speed ECM Configuration Mode

The control is placed in the ECM configuration mode by holding the pushbutton switch SW1 for 5 to 10 seconds, the high, low, and “G” ECM speeds can be selected by following the LED display lights. LED2 (yellow) will fast flash when entering the ECM configuration. When setting “G” speed LED3 (green) will be continuously lit, for low speed LED1 (red) will be continuously lit, and for high speed both LED3 (green) and LED1 (red) will be continuously lit. During the ECM configuration mode LED2 (yellow) will flash each of the 12 possible blower speeds 3 times. When the desired speed is flashed press SW1, LED2 will fast flash until SW1 is released. “G” speed has now been selected. Next select low speed, and high speed blower selections following the same process above. After third selection has been made, the control will exit the ECM configuration mode. Aux fan speed will remain at default or current setting and requires the AID Tool for adjustment.

Reset Configuration Mode

The control is placed in reset configuration mode by holding the push button switch SW1 for 50 to 60 seconds. This will reset all configuration settings and the EEPROM back to the factory default settings. LED3 (green) will turn off when entering reset configuration mode. Once LED3 (green) turns off, release SW1 and the control will reset.

DIP Switch (SW2)

SW2-1 FP1 Selection – Low water coil temperature limit setting for freeze detection. On = 30°F; Off = 15°F.

SW2-2 FP2 Selection – On = 30°F; Off = N/A

SW2-3 RV – O/B - thermostat type. Heat pump thermostats with “O” output in cooling or “B” output in Heating can be selected. On = O; Off = B.

SW2-4 and 2-5 Access Relay Operation (P2)

Access Relay Operation	SW2-4	SW2-5
Cycle with Blower	ON	ON
Cycle with Compressor	OFF	OFF
Water Valve Slow Opening	ON	OFF
Cycle with Comm. T-stat Hum Cmd	OFF	ON

The Aurora ‘Base’ Control System cont.

Cycle with Blower - The accessory relay will cycle with the blower output.

Cycle with Compressor - The accessory relay will cycle with the compressor output.

Water Valve Slow Opening - The accessory relay will cycle and delay both the blower and compressor output for 90 seconds.

SW2-6 CC Operation - selection of single or dual capacity compressor. On = Single Stage; Off = Dual Capacity

SW2-7 Lockout and Alarm Outputs (P2) - selection of a continuous or pulsed output for both the LO and ALM Outputs. On = Continuous; Off = Pulsed

SW2-8 Future Use - Must be in the on position.

Alarm Jumper Clip Selection

From the factory, ALM is connected to 24 VAC via JW2. By cutting JW2, ALM becomes a dry contact connected to ALG.

Variable Speed ECM Blower Speeds

The blower speeds can be changed either by using the ECM manual configurations mode method or by using the Aurora AID Tool directly (see Instruction Guide: Aurora Interface and Diagnostics (AID) Tool topic).

Field Selectable Options via Software

(Selectable via the Aurora AID Tool)

Variable Speed ECM Blower Speeds

An ECM blower motor can be driven directly using the onboard PWM output. Four blower speeds are available, based upon the “G”, Y1 (low), Y2 (high), and Aux input signals to the board. The blower speeds can be changed either by the ECM manual configurations mode method (see ECM Configuration Mode topic) or by using the Aurora AID Tool directly. All four blower speeds can be set to the same speed if desired. Aux blower speed will remain at default or current setting and requires the AID Tool for adjustment.

Safety Features

The following safety features are provided to protect the compressor, heat exchangers, wiring and other components from damage caused by operation outside of design conditions.

Fuse - a 3 amp automotive type plug-in fuse provides protection against short circuit or overload conditions.

Anti-Short Cycle Protection - 4 minute anti-short cycle protection for the compressor.

Random Start - 5 to 80 second random start upon power up.

Fault Retry - in the fault condition, the control will stage off the outputs and then “try again” to satisfy the thermostat Y input call. Once the thermostat input calls are satisfied, the control will continue on as if no fault occurred. If 3 consecutive faults occur without satisfying the thermostat Y input call, then the control will go to Lockout mode.

Lockout - when locked out, the blower will operate continuously in “G” speed. The Alarm output (ALM) and Lockout output (L) will be turned on. The fault type identification display LED1 (Red) shall flash the fault code. To reset lockout conditions with SW2-8 On, thermostat inputs “Y1”, “Y2”, and “W” must be removed for at least 3 seconds. To reset lockout conditions with SW2-8 Off, thermostat inputs “Y1”, “Y2”, “W”, and “DH” must be removed for at least 3 seconds. Lockout may also be reset by turning power off for at least 30 seconds or by enabling the emergency shutdown input for at least 3 seconds.

Lockout With Emergency Heat - if the control is locked out in the heating mode, and a Y2 or W input is received, the control will operate in the emergency heat mode while the compressor is locked out. The first emergency heat output will be energized 10 seconds after the W input is received, and the blower will shift to high speed. If the control remains locked out, and the W input is present, additional stage of emergency heat will stage on after 2 minutes. When the W input is removed, all of the emergency heat outputs will turn off, and the ECM blower will shift to “G” speed.

High Pressure - fault is recognized when the Normally Closed High Pressure Switch, P4-9/10 opens, no matter how momentarily. The High Pressure Switch is electrically in series with the Compressor Contactor and serves as a hard-wired limit switch if an overpressure condition should occur.

Low Pressure - fault is recognized when the Normally Closed Low Pressure Switch, P4-7/8 is continuously open for 30 seconds. Closure of the LPS any time during the 30 second recognition time restarts the 30 second continuous open requirement. A continuously open LPS shall not be recognized during the 2 minute startup bypass time.

Loss of Charge - fault is recognized when the Normally Closed Low Pressure Switch, P4-7/8 is open prior to the compressor starting.

Condensate Overflow - fault is recognized when the impedance between this line and 24 VAC common or chassis ground drops below 100K ohms for 30 seconds continuously.

Freeze Detection (Coax) - set points shall be either 30°F or 15°F. When the thermistor temperature drops below the selected set point, the control shall begin counting down the 30 seconds delay. If the thermistor value rises above the selected set point, then the count should reset. The resistance value must remain below the selected set point for the entire length of the appropriate delay to be recognized as a fault. This fault will be ignored for the initial 2 minutes of the compressor run time.

Freeze Detection (Air Coil) - uses the FP2 input to protect against ice formation on the air coil. The FP2 input will operate exactly like FP1 except that the set point is 30 degrees and is not field adjustable.

The Aurora 'Base' Control System cont.

Secondary Freeze Detection - A freeze detection thermostat is installed inside the cabinet to automatically start the loop pump if temperature drops below 20°F.

Over/Under Voltage Shutdown - An over/under voltage condition exists when the control voltage is outside the range of 18 VAC to 30 VAC. If the over/under voltage shutdown lasts for 15 minutes, the lockout and alarm relay will be energized. Over/under voltage shutdown is self-resetting in that if the voltage comes back within range of 18 VAC to 30 VAC for at least 0.5 seconds, then normal operation is restored.

Operation Description

Power Up - The unit will not operate until all the inputs and safety controls are checked for normal conditions. The unit has a 5 to 80 second random start delay at power up. Then the compressor has a 4 minute anti-short cycle delay after the random start delay.

Standby In standby mode, Y1, Y2, W, DH, and G are not active. Input O may be active. The blower and compressor will be off.

Heating Operation

Heating, 1st Stage (Y1) - The blower is started on "G" speed immediately and the compressor is energized 10 seconds after the Y1 input is received. The ECM blower motor is switched to low speed 15 seconds after the Y1 input.

Heating, 2nd Stage (Y1, Y2) - The compressor will be staged to full capacity 20 seconds after Y2 input is received. The ECM blower will shift to high speed 15 seconds after the Y2 input is received.

Heating, 3rd Stage (Y1, Y2, W) - First stage of electric heat is energized 10 seconds after the W command is received. If the demand continues the second stage of electric heat will be energized after 5 minutes.

Emergency Heat (W) - The blower will be started on "G" speed, 10 seconds later the first stage of electric heat will be turned on. 5 seconds after the first stage of electric heat is energized the blower will shift to Aux speed. If the emergency heat demand is not satisfied after 2 minutes the second electric heat stage will be energized.

Cooling Operation

In all cooling operations, the reversing valve directly tracks the O input. Thus, anytime the O input is present, the reversing valve will be energized.

Cooling, 1st Stage (Y1, O) - The blower is started on "G" speed immediately and the compressor is energized 10 seconds after the Y1 input is received. The ECM blower motor is switched to low speed 15 seconds after the Y1 input.

Cooling, 2nd Stage (Y1, Y2, O) - The compressor will be staged to full capacity 20 seconds after Y2 input is received. The ECM blower will shift to high speed 15 seconds after the Y2 input is received.

Blower (G) - The blower will start immediately upon receiving a thermostat G command. If there are no other commands from the thermostat the ECM will run on "G" speed until the G command is removed. Regardless of blower input (G) from the thermostat, the blower will remain on for 30 seconds at the end of each heating, cooling, and emergency heat cycle.

Dehumidification (Y1, O, DH or Y1, Y2, O, DH) - When a DH command is received from the thermostat during a compressor call for cooling the ECM blower speed will be reduced by 15% to increase dehumidification.

Emergency Shutdown - Four (4) seconds after a valid ES input, P2-7 is present, all control outputs will be turned off and remain off until the emergency shutdown input is no longer present. The first time that the compressor is started after the control exits the emergency shutdown mode, there will be an anti-short cycle delay followed by a random start delay. Input must be tied to common to activate.

Continuous Blower Operation - The blower output will be energized any time the control has a G input present, unless the control has an emergency shutdown input present. The blower output will be turned off when G input is removed.

Load Shed - The LS input disables all outputs with the exception of the blower output. When the LS input has been cleared, the anti-short cycle timer and random start timer will be initiated. Input must be tied to common to activate.

The Aurora 'Base' Control System cont.

Aurora 'Base' Control LED Displays

These three LEDs display the status, configuration, and fault codes for the control. These can also be read in plain English via the Aurora AID Tool.

Status LED (LED3, Green)

Description of Operation	Fault LED, Green
Normal Mode	ON
Control is Non-functional	OFF
Test Mode	Slow Flash
Lockout Active	Fast Flash
Dehumidification Mode	Flash Code 2
(Future Use)	Flash Code 3
(Future Use)	Flash Code 4
Load Shed	Flash Code 5
ESD	Flash Code 6
(Future Use)	Flash Code 7

Configuration LED (LED2, Yellow)

Description of Operation	Configuration LED, Yellow
No Software Overwritten	Flashing ECM Setting
DIP Switch was Overwritten	Slow Flash
ECM Configuration Mode	Fast Flash

Fault LED (LED1, Red)

Red Fault LED	LED Flash Code*	Lockout	Reset/Remove
Normal - No Faults	OFF	-	
Fault - Input	1	No	Auto
Fault - High Pressure	2	Yes	Hard or Soft
Fault - Low Pressure	3	Yes	Hard or Soft
Fault - Freeze Detection FP2	4	Yes	Hard or Soft
Fault - Freeze Detection FP1	5	Yes	Hard or Soft
Fault - Condensate Overflow	7	Yes	Hard or Soft
Fault - Over/Under Voltage	8	No	Auto
Fault - FP1 Sensor Error	11	Yes	Hard or Soft
Fault - CritComErr	19	NO	Auto

NOTE: All codes >11 use long flash for tens digit and short flash for the ones digit. 20, 30, 40, 50, etc. are skipped.

Aurora Interface and Diagnostics (AID) Tool

The Aurora Interface and Diagnostics (AID) Tool is a device that is a member of the Aurora network. The AID Tool is used to troubleshoot equipment which uses the Aurora control via Modbus RTU communication. The AID Tool provides diagnostics, fault management, variable speed ECM setup, and system configuration capabilities to the Aurora family of controls. An AID Tool is recommended, although not required, for ECM airflow settings. The AID Tool simply plugs into the RS485 net (P8) connector on the ABC control board.



ABC Control Board Layout

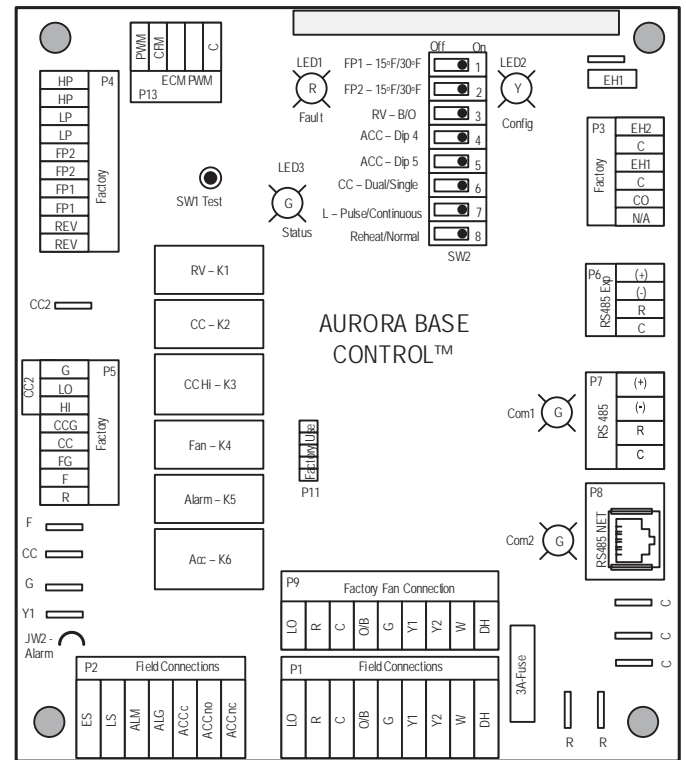

The Aurora ‘Advanced’ Control System

Aurora ‘Advanced’ Control Features

The Aurora ‘Advanced’ Control system expands on the capability of the Aurora ‘Base’ Control (ABC) by adding the Aurora Expansion Board (AXB). All of the preceding features of the Aurora ‘Base’ Control are included. The following control description is of the additional features and capability of the Aurora advanced control.

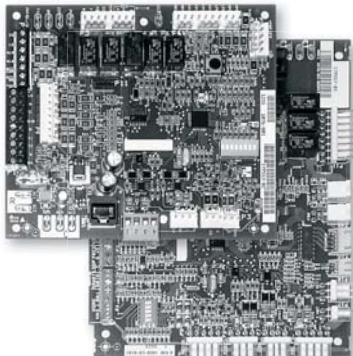

It is highly recommended the installing/servicing contractor obtain an Aurora Interface and Diagnostic Tool (AID) and specialized training before attempting to install or service an Aurora ‘Advanced’ control system.



The additional AXB features include the following:

AXB DIP Switch

DIP 1 - ID: This is the AXB ModBus ID and should always read On.

DIP 2 & 3 - Future Use

DIP 4 & 5 - Accessory Relay2: A second, DIP configurable, accessory relay is provided that can be cycled with the compressor 1 or 2, blower, or the Dehumidifier (DH) input. This is to complement the Accessory 1 Relay on the ABC board.

Position	DIP 4	DIP 5	Description
1	ON	ON	Cycles with Fan or ECM (or G)
2	OFF	ON	Cycles with CC1 first stage of compressor or compressor spd 1-6
3	ON	OFF	Cycles with CC2 second stage of compressor or compressor spd 7-12
4	OFF	OFF	Cycles with DH input from ABC board

Compressor Monitoring

The AXB includes two current transducers to monitor the compressor current and starting characteristics. Open circuits or welded contactor faults will be detected. A fault will produce an E10 code.

IntelliZone2 Zoning Compatibility (Optional IntelliZone2 Communicating Zoning)

A dedicated input to connect and communicate with the IntelliZone2 (IZ2) zoning system is provided on P7 on the AXB. There is a dedicated communication port using a proprietary ModBus protocol. An AXB is required. Consult the IntelliZone2 literature for more information. IntelliZone2 should be mounted indoors.

AWL - Aurora Weblink (if available) (optional accessory)

AWL is an add-on WiFi router that connects to the ABC and offers many features:

- Remote access to thermostat settings, schedules, etc. with your smartphone, tablet or laptop
- Receive Lockout/Fault info via text or e-mail
- View heat pump energy usage from the Internet for the day, week, month, year or real-time
- Internet AID Tool capability allows remote troubleshooting for the technician
- Remote AID Tool capability at the heat pump with smartphone, tablet or laptop for the technician
- Allows data acquisition of the heat pump through the Internet, see graphs of performance and chart historical data for the technician
- Stores historical data on SD card

NOTE: The AWL should be installed indoors and the Ethernet cable supplied with the AWL should be run inside conduit to the outdoor unit and connected to the ABC P8 (RS485 NET). Cable should not be in conduit that includes high voltage wires. If the cable supplied with the AWL is not long enough you may purchase standard Cat6 Ethernet cable locally or order our part number 11P951-01, 100’ Cat6 cable. The maximum Cat6 cable length should be kept to 150’ or less.

Advanced Communication Ports

Communication ports P6 and P8 will provide future expansion via dedicated protocols. These are for future use.

Smart Grid-On Peak (SG) Input

The ‘On Peak’ input was designed to allow utilities to utilize simple radio controlled switches to control the On Electric Peak behavior of the Heat Pump. With a closed contact signal, this input will limit the operation and thus the power consumption of the unit by one of the below selections. The AID Tool will allow configuration of this input for the action of:

- No Action
- Disable compressor operation until removed
- Go to On Peak thermostat settings until removed [Requires Com T-Stat] (Future Release)
- Compressor limited to low cap until removed (Future Release)
- Disable compressor operation for 1/2 hr (can be removed immediately) (Future Release)

Then Flash Code 7 on the Green LED for the ‘On Peak’ mode. And On Peak will display on communicating thermostats.

The Aurora ‘Advanced’ Control System cont.

Home Automation 1 and 2 Inputs

The Home automation inputs are simple closed contact inputs that will trigger an AID Tool and thermostat alert for the homeowner. These would require optional sensors and or equipment for connection to the AXB board. With two inputs two different sensors can be selected. The selected text will then be displayed on the AID Tool and communicating thermostats. These events will NOT alter functionality or operation of the heat pump/accessories and is for homeowner/ service notification only.

Home Automation 1 - E23 HA1

With a closed dry contact signal, this input will cause an alarm and Alert Code 23 to indicate on the stat or flash on ABC. The AID Tool will allow configuration of this input between the following selections:

- No Action
- Home Automation Fault [no lockout info only]
 - Output from home automation system
- Security Alarm [no lockout info only]
 - Output from home security
- Sump Alarm Fault [no lockout info only]
 - Switch output from sump sensor
- Smoke/CO Alarm Fault [no lockout info only]
 - Switch output from Smoke/CO sensor
- Dirty Filter Alarm [no lockout info only]
 - Output from dirty filter sensor

Home Automation 2 - E24 HA2

With a closed dry contact signal, this input will cause an alarm and Alert Code 24 to indicate on the stat or flash on ABC. The AID Tool will allow configuration of this input between the following selections:

- No Action
- Home Automation Fault [no lockout info only]
 - Output from home automation system
- Security Alarm [no lockout info only]
 - Output from home security
- Sump Alarm Fault [no lockout info only]
 - Switch output from sump sensor
- Smoke/CO Alarm Fault [no lockout info only]
 - Switch output from Smoke/CO sensor
- Dirty Filter Alarm [no lockout info only]
 - Output from dirty filter sensor

Monitoring Sensor Kits

Energy Monitoring (Standard Sensor Kit on ‘Advanced’ models)

The Energy Monitoring Kit includes two current transducers (blower and electric heat) added to the existing two compressor sensors so that the complete power usage of the heat pump can be measured. The AID Tool provides configuration detail for the type of blower motor, power adjustment and a line voltage calibration procedure to improve the accuracy, and a power adjustment setting that allows the compressor power to be adjusted to match the unit’s line voltage using the provided tables. This information can be displayed on the AID Tool, selected communicating thermostats or Symphony. The TPCM32U03A*/O4A* will display instantaneous energy use while the color touchscreen TPCC32U01* will in addition display a 13 month history in graph form. Refer to Unit Start Up Energy Monitoring for configuration details.

Dual Capacity Power Adjustment

Model	Unit Capacity	Voltage		
		208	230	250
026	Full Load	0.99	0.99	0.96
	Part Load	0.99	0.99	0.93
038	Full Load	0.99	0.97	0.91
	Part Load	0.99	0.94	0.83
049	Full Load	0.94	0.91	0.85
	Part Load	0.91	0.84	0.75
064	Full Load	0.95	0.9	0.79
	Part Load	0.92	0.83	0.71
072	Full Load	0.94	0.86	0.73
	Part Load	0.92	0.81	0.65

Refrigerant Monitoring (optional sensor kit)

The optional Refrigerant Monitoring Kit includes two pressure transducers, and three temperature sensors, heating liquid line, suction temperature and existing cooling liquid line (FP1). These sensors allow the measurement of discharge and suction pressures, suction and liquid line temperatures as well as superheat and subcooling. This information will only be displayed on the AID Tool or Symphony.

Performance Monitoring (optional sensor kit)

The optional Performance Monitoring Kit includes three temperature sensors, entering and leaving water, leaving air temperature and a water flow rate sensor. With this kit heat of extraction and rejection will be calculated. This requires configuration using the AID Tool for selection of water or antifreeze. This information can only be displayed on the AID tool or Symphony.

The Aurora ‘Advanced’ Control System cont.

Special Modes and Applications Communicating Digital Thermostats

The Aurora controls system also features either mono-chromatic or color touch screen graphic display thermostats for user interface. These displays not only feature easy to use graphical interface but display alerts and faults in plain English. Many of the features discussed here may not be applicable without these thermostats.

Dehumidification - Passive

In passive dehumidification mode with a Variable Speed ECM motor the airflow is reduced by 15% from the heating airflow setting. If cooling airflow is set to +5, -5 or -10% of heating airflow it will automatically be set to -15% of heating airflow whenever the dehumidification call is present in the communicating stat or from the thermostat input DH. If the airflow for cooling is already set to -15% no airflow change will be noticed from normal cooling. Dehumidification mode will be shown on the ABC and the communicating thermostats.

Aurora ‘Advanced’ Control LED Displays

These three LEDs display the status, configuration, and fault codes for the control. These can also be read in plain English via the Aurora AID Tool.

Status LED (LED3, Green)

Description of Operation	Fault LED, Green
Normal Mode	ON
Control is Non-functional	OFF
Test Mode	Slow Flash
Lockout Active	Fast Flash
Dehumidification Mode	Flash Code 2
Load Shed	Flash Code 5
Emergency Shutdown	Flash Code 6
On Peak Mode	Flash Code 7
(Future Use)	Flash Code 8
(Future Use)	Flash Code 9

Configuration LED (LED2, Yellow)

Description of Operation	Configuration LED, Yellow
No Software Overwritten	ECM Setting
DIP Switch Overwritten	Slow Flash
ECM Configuration Mode	Fast Flash
Reset Configuration Mode	OFF

Fault LED (LED1, Red)

Red Fault LED	LED Flash Code *	Lockout	Reset/ Remove	Fault Condition Summary
Normal - No Faults	Off	-		
ABC Basic Faults				
Fault-Input	1	No	Auto	Tstat input error. Autoreset upon condition removal.
Fault-High Pressure	2	Yes	Hard or Soft	HP switch has tripped (>600 psi)
Fault-Low Pressure	3	Yes	Hard or Soft	Low Pressure Switch has tripped (<40 psi for 30 continuous sec.)
Fault-Freeze Detection FP2	4	Yes	Hard or Soft	Freeze protection sensor has tripped (<15 or 30 degF for 30 continuous sec.)
Fault-Freeze Detection FP1	5	Yes	Hard or Soft	Freeze protection sensor has tripped (<15 or 30 degF for 30 continuous sec.)
Fault-Condensate Overflow	7	Yes	Hard or Soft	Condensate switch has shown continuity for 30 continuous sec.
Fault-Over/Under Voltage	8	No	Auto	Instantaneous voltage is out of range. **Controls shut down until resolved.
Fault-FP1 Sensor Error	11	Yes	Hard or Soft	FP1 Sensor Open or Shorted
ABC & AXB Advanced				
Fault-Compressor Monitor	10	Yes	Hard or Soft	Open Crkt, Run, Start or welded cont
Non-CriticAXB SnsrErr	13	No	Auto	Any Other Sensor Error
CriticAXBSnsrErr	14	Yes	Hard or Soft	Sensor Error for EEV or HW
Alert-HotWtr	15	No	Auto	HW over limit or logic lockout. HW pump deactivated.
Fault-VarSpdPump	16	No	Auto	Alert is read from PWM feedback.
Non-CritComErr	18	No	Auto	Any non-critical com error
Fault-CritComErr	19	No	Auto	Any critical com error. Auto reset upon condition removal
Alarm - Low Loop Pressure	21	No	Auto	Loop pressure is below 3 psi for more than 3 minutes
Alarm - Home Automation 1	23	No	Auto	Closed contact input is present on Dig 2 input - Text is configurable
Alarm - Home Automation 2	24	No	Auto	Closed contact input is present on Dig 3 input - Text is configurable

NOTES:

*All codes >11 use long flash for tens digit and short flash for the ones digit. 20, 30, 40, 50 etc. are skipped!
Alert' is a noncritical sensor or function that has failed. Normal operation of the heat pump is maintained but service is desired at some point.

Reference Calculations

Heating Calculations:	Cooling Calculations:
$LWT = EWT - \frac{HE}{gpm \times 500}$	$LWT = EWT + \frac{HR}{gpm \times 500}$
$LAT = EAT + \frac{HC}{cfm \times 1.08}$	$LAT (DB) = EAT (DB) - \frac{SC}{cfm \times 1.08}$
$TH = HC + HW$	$LC = TC - SC$
	$S/T = \frac{SC}{TC}$

Legend

Abbreviations and Definitions

cfm = airflow, cubic feet/minute	HWC = hot water generator capacity, MBtu/h
EWT = entering water temperature, Fahrenheit	EER = Energy Efficient Ratio
gpm = water flow in gallons/minute	= Btu output/Watt input
WPD = water pressure drop, psi and feet of water	COP = Coefficient of Performance
EAT = entering air temperature, Fahrenheit (dry bulb/wet bulb)	= Btu output/Btu input
HC = air heating capacity, MBtu/h	LWT = leaving water temperature, °F
TC = total cooling capacity, MBtu/h	LAT = leaving air temperature, °F
SC = sensible cooling capacity, MBtu/h	TH = total heating capacity, MBtu/h
kW = total power unit input, kilowatts	LC = latent cooling capacity, MBtu/h
HR = total heat of rejection, MBtu/h	S/T = sensible to total cooling ratio
HE = total heat of extraction, MBtu/h	

Operating Limits

Operating Limits	Cooling		Heating	
	(°F)	(°C)	(°F)	(°C)
Air Limits				
Min. Ambient Air	-10	-23.3	-10	-23.3
Rated Ambient Air	80	26.7	70	21.1
Max. Ambient Air	100	37.8	85	29.4
Min. Entering Air	50	10.0	40	4.4
Rated Entering Air db/wb	80.6/66.2	27/19	68	20.0
Max. Entering Air db/wb	110/83	43/28.3	80	26.7
Water Limits				
Min. Entering Water	30	-1.1	30	-1.1
Normal Entering Water	50-110	10-43.3	30-70	-1.1
Max. Entering Water	120	48.9	90	32.2
Nominal Water Flow	1.5 to 3.0 gpm per ton (1.6 to 3.2 l/m per kW)			

Notes:

Minimum/maximum limits are only for start-up conditions, and are meant for bringing the space up to occupancy temperature. Units are not designed to operate at the minimum/maximum conditions on a regular basis. The operating limits are dependent upon three primary factors: 1) water temperature, 2) return air temperature, and 3) ambient temperature. When any of the factors are at the minimum or maximum levels, the other two factors must be at the normal level for proper and reliable unit operation.

Wiring Schematics

Aurora Base Controls with ECM and IntelliStart

For optional Flow Center and Water Valve wiring schematics refer to the appropriate schematic.

For optional IntelliStart wiring schematics refer to the appropriate schematic.

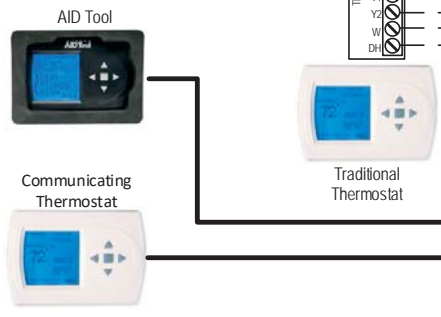
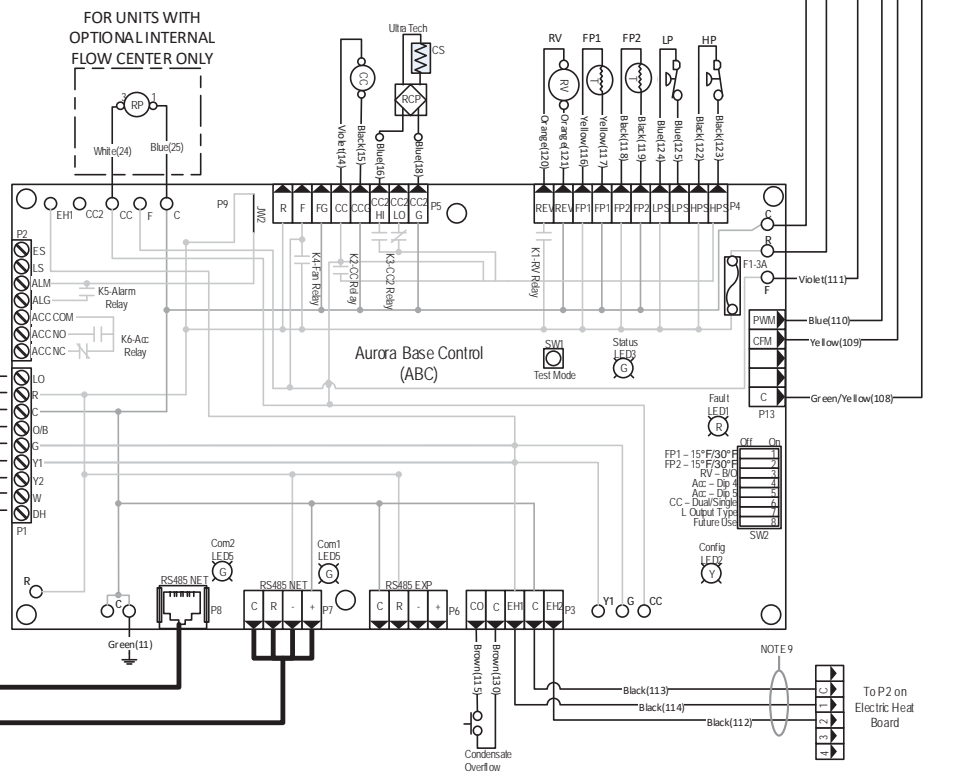
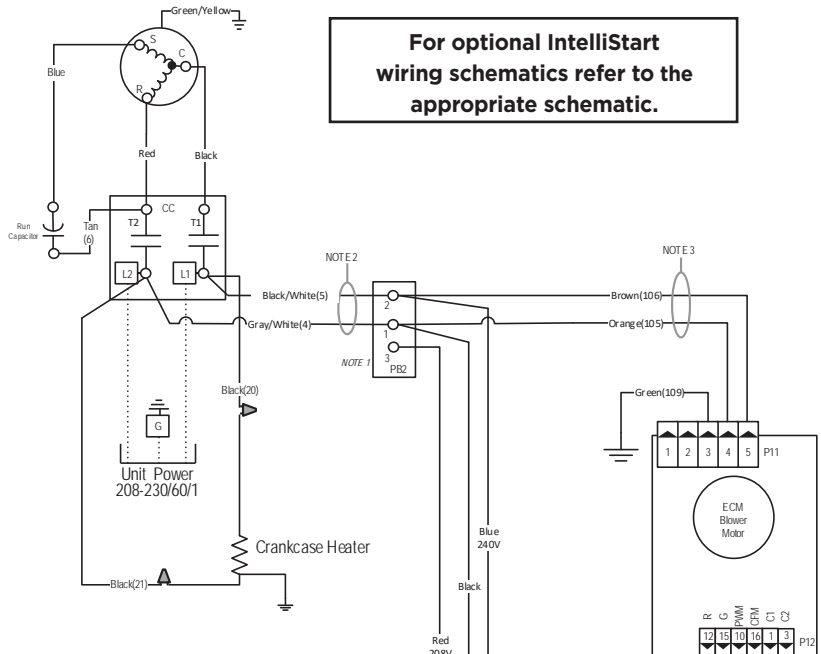

Wiring Schematics cont.

Aurora Base Controls with ECM and IntelliStart cont.

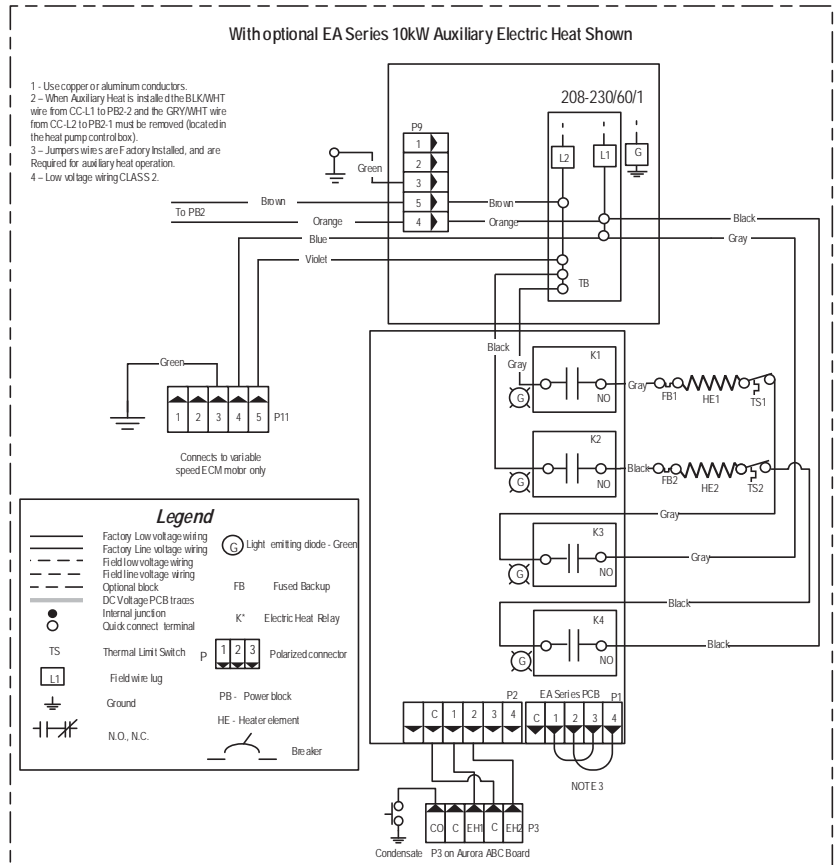

- Notes**
- 1 - Switch blue and red wires for 208V operation.
 - 2 - The blk/wht and gray/wht wires are removed when Aux Heat is installed
 - 3 - When Auxiliary Heat is field installed the harness will then be connected to the auxiliary heat unit. The auxiliary heat unit will then power the blower. Refer to EAS/EAMEAL Auxiliary Heat kit installation instructions.
 - 4 - Low voltage wiring CLASS 2.
 - 5 - Brown blower power wire routed through Current Transducer two times.
 - 6 - Field Connected: Refer to Installation Manual and Auxiliary Heat Instructions for Current Transducer installation.
 - 7 - Wires provided for Auxiliary Heat low voltage control. Wires are secured at blower.

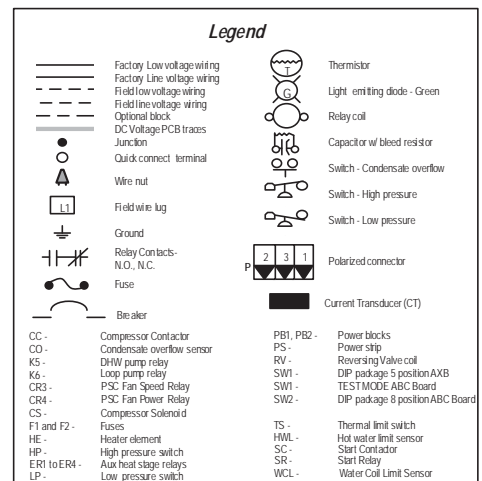

Wiring Schematics cont.

Aurora Base Controls with ECM and IntelliStart

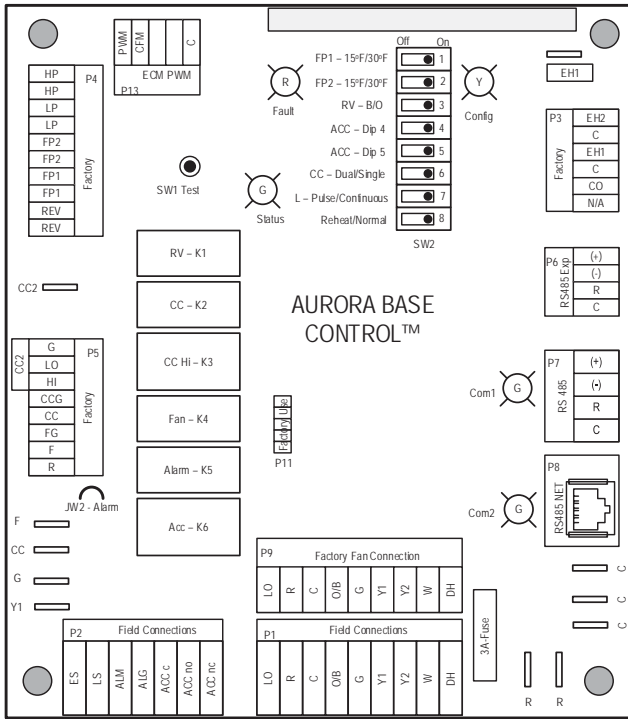

ABC SW2 Accessory Relay		
DESCRIPTION	SW2-4	SW2-5
Cycle with Blower	ON	ON
Cycle with Compressor	OFF	OFF
Water Valve Slow Opening	ON	OFF
Cycle with Comm. T-stat Hum Cmd	OFF	ON

Aurora LED Flash Codes			
Slow Flash	1 second on and 1 second off		
Fast Flash	100 milliseconds on and 100 milliseconds off		
Flash Code	100 milliseconds on and 400 milliseconds off with a 2 second pause before repeating		
Random Start Delay (Alternating Colors)		Configuration LED (LED2, Yellow)	
Status LED (LED1, Green)	Fast Flash	No Software Override	OFF
Configuration LED (LED2, Yellow)	Fast Flash	DIP Switch Override	Slow Flash
Fault LED (LED3, Red)	Fast Flash		
Fault LED (LED1, Red)		Status LED (LED3, Green)	
Normal Mode	OFF	Normal Mode	ON
Input Fault Lockout	Flash Code 1	Control is Non-Functional	OFF
High Pressure Lockout	Flash Code 2	Test Mode	Slow Flash
Low Pressure Lockout	Flash Code 3	Lockout Active	Fast Flash
Future Use	Flash Code 4	Dehumidification Mode	Flash Code 2
Freeze Detection - FP1	Flash Code 5	Future Use	Flash Code 3
Reserved	Flash Code 6	Future Use	Flash Code 4
Condensate Overflow Lockout	Flash Code 7	Load Shed	Flash Code 5
Over/Under Voltage Shutdown	Flash Code 8	ESD	Flash Code 6
Future Use	Flash Code 9	Future Use	Flash Code 7
Future Use	Flash Code 10		
FP1 and FP2 Sensor Error	Flash Code 11		

- Notes
- 1 - Switch blue and red wires for 208V operation.
 - 2 - The blk/wh and gray/wh wires are removed when Aux Heat is installed
 - 3 - When Auxiliary Heat is field installed the harness will then be connected to the auxiliary heat unit. The auxiliary heat unit will then power the blower. Refer to EAS/EAM/EAL Auxiliary Heat kit installation instructions.
 - 4 - Low voltage wiring CLASS 2.
 - 5 - Brown blower power wire routed through Current Transducer two times
 - 6 - Field Connected; Refer to Installation Manual and Auxiliary Heat Instructions for Current Transducer installation.
 - 7 - Wires provided for Auxiliary Heat low voltage control. Wires are secured at blower.

Wiring Schematics cont.

Aurora Base Controls with ECM and IntelliStart

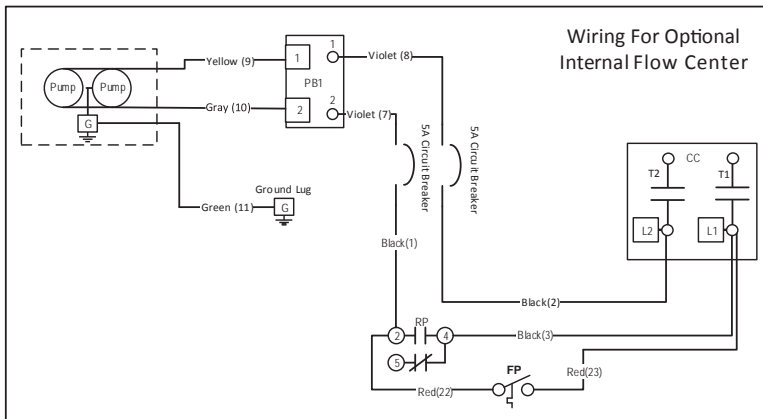
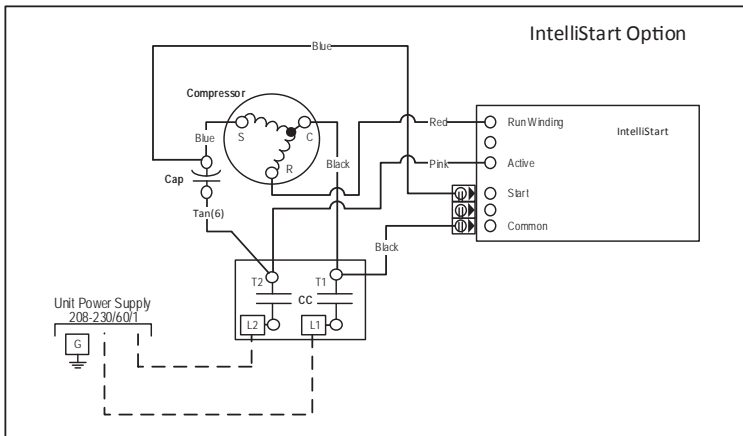
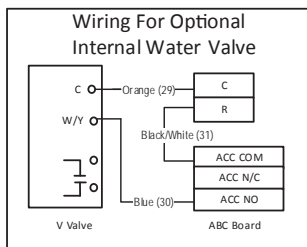

Legend

	Factory Low voltage wiring		Thermistor
	Factory Line voltage wiring		Light emitting diode - Green
	Field low voltage wiring		Relay coil
	Field line voltage wiring		Capacitor w/ bleed resistor
	Optional block		Switch - Condensate overflow
	DC Voltage PCB traces		Switch - High pressure
	Junction		Switch - Low pressure
	Quick connect terminal		Polarized connector
	Wire nut		Current Transducer (CT)
	Field wire lug		
	Ground		
	Relay Contacts- N.O., N.C.		
	Fuse		
	Breaker		

CC - Compressor Contactor	PB1, PB2 - Power blocks
CO - Condensate overflow sensor	PS - Power strip
K5 - DHW pump relay	RV - Reversing Valve coil
K6 - Loop pump relay	SW1 - DIP package: 5 position AXB
CR3 - PSC Fan Speed Relay	SWT - TEST MODE ABC Board
CR4 - PSC Fan Power Relay	SW2 - DIP package: 8 position ABC Board
CS - Compressor S/dendid	
F1 and F2 - Fuses	TS - Thermal limit switch
HE - Heater element	HWL - Hot water limit sensor
HP - High pressure switch	SC - Start Contactor
ER1 to ER4 - Aux heat stage relays	SR - Start Relay
LP - Low pressure switch	WCL - Water Coil Limit Sensor

Wiring Schematics cont.

Aurora Advanced Controls with ECM and IntelliStart

For optional Flow Center and Water Valve wiring schematics refer to the appropriate schematic.

For optional IntelliStart wiring schematic refer to the appropriate schematic.

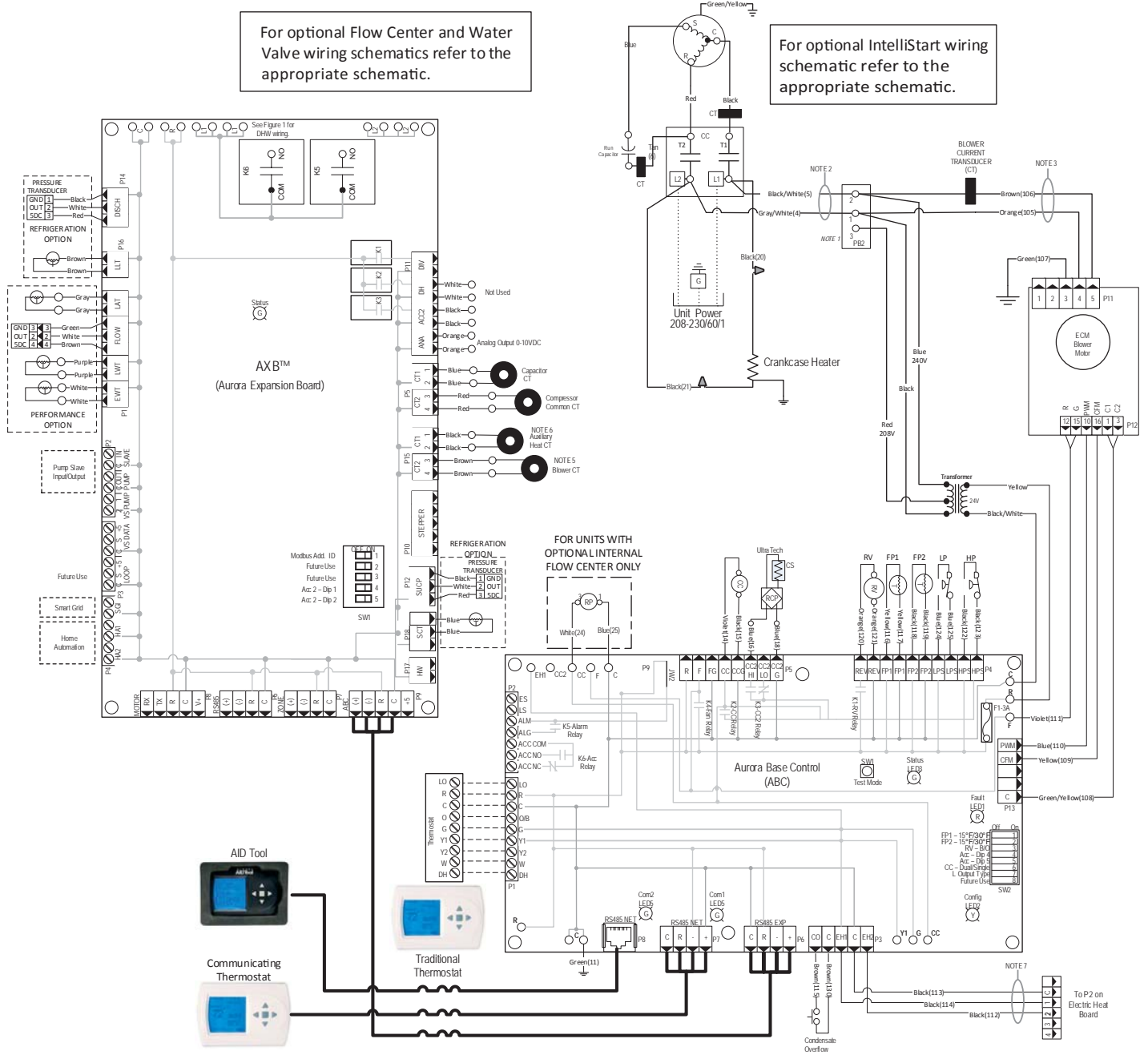

Wiring Schematics cont.

Aurora Advanced Controls with ECM and IntelliStart cont.

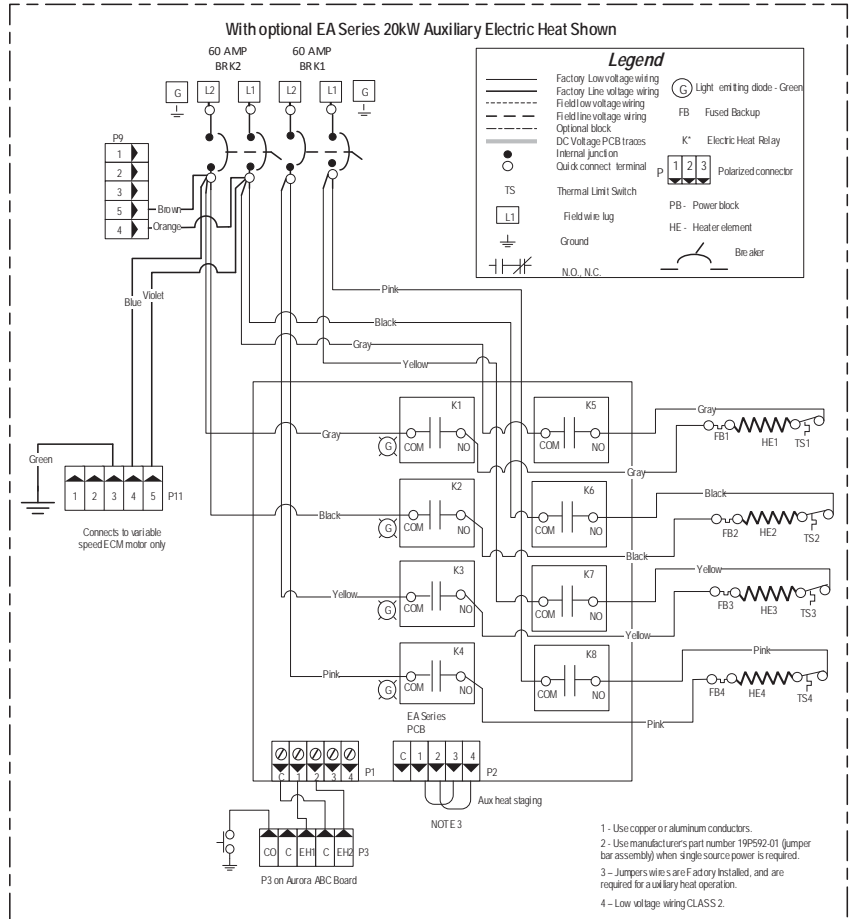

- Notes**
- 1 - Switch blue and red wires for 208V operation.
 - 2 - The blk/wh and gray/wh wires are removed when Aux Heat is installed
 - 3 - When Auxiliary Heat is field installed the harness will then be connected to the auxiliary heat unit. The auxiliary heat unit will then power the blower. Refer to EAS/EAM/EAL Auxiliary Heat kit installation instructions
 - 4 - Low voltage wiring CLASS 2.
 - 5 - Brown blower power wire routed through Current Transducer two times.
 - 6 - Field Connected; Refer to Installation Manual and Auxiliary Heat Instructions for Current Transducer installation.
 - 7 - Wires provided for Auxiliary Heat low voltage control. Wires are secured at blower.

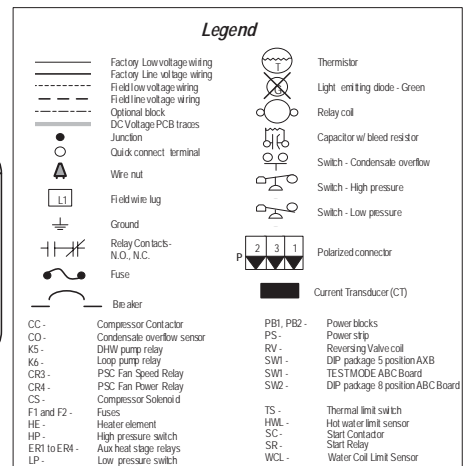

Wiring Schematics cont.

Aurora Advanced with ECM and IntelliStart

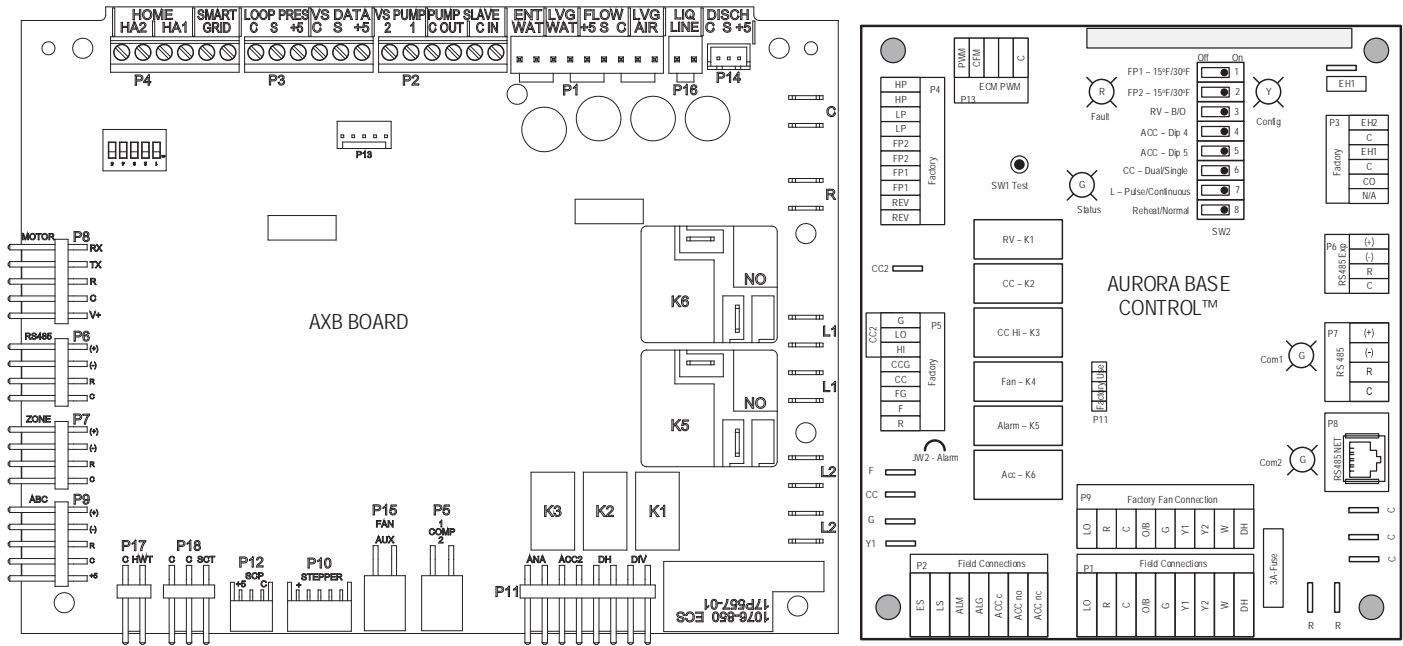

Aurora LED Flash Codes			
Slow Flash	1 second on and 1 second off		
Fast Flash	100 milliseconds on and 100 milliseconds off		
Flash Code	100 milliseconds on and 400 milliseconds off with a 2 second pause before repeating		
Fault LED (LED 1, Red)		Random Start Delay (Alternating Colors)	
Normal Mode	OFF	Status LED (LED1, Green)	Fast Flash
Input Fault Lockout	Flash Code 1	Configuration LED (LED 2, Yellow)	Fast Flash
High Pressure Lockout	Flash Code 2	Fault LED (LED 3, Red)	Fast Flash
Low Pressure Lockout	Flash Code 3	Configuration LED (LED 2, Yellow)	
Freeze Detection - FP2	Flash Code 4	No Software Override	OFF
Freeze Detection - FP1	Flash Code 5	DIP Switch Override	Slow Flash
Reserved	Flash Code 6	Status LED (LED 3, Green)	
Condensate Overflow Lockout	Flash Code 7	Normal Mode	ON
Over/Under Voltage Shutdown	Flash Code 8	Control is Non - Functional	OFF
Future Use	Flash Code 9	Test Mode	Slow Flash
Compressor Monitoring	Flash Code 10	Lockout Active	Fast Flash
Fault- FP1 Sensor Error	Flash Code 11	Dehumidification Mode	Flash Code 2
Future Use	Flash Code 12	Future Use	Flash Code 3
Non-Critical AXB Sensor Error	Flash Code 13	Future Use	Flash Code 4
Critical AXB Sensor Error	Flash Code 14	Load Shed	Flash Code 5
Alarm - Hot Water	Flash Code 15	ESD	Flash Code 6
Fault Variable Speed Pump	Flash Code 16	Future Use	Flash Code 7
Future Use	Flash Code 17	Fault LED (LED 1, Red) Cont.	
Non-Critical Communication Error	Flash Code 18	Alarm - Home Automation 1	Flash Code 23
Fault - Critical Communication Error	Flash Code 19	Alarm - Home Automation 2	Flash Code 24
Alarm - Low Loop Pressure	Flash Code 21	Fault - EEV Error	Flash Code 25
Fault - Communication ECM Fan Motor Error	Flash Code 22		

AXB Accessory 2 DIP Settings		
SW1-4	SW1-5	DESCRIPTION
ON	ON	Cycles with Blower
OFF	ON	Cycles with CC first stage compressor or compressor spd 1-12
ON	OFF	Cycles with CC2 second stage of compressor or comp spd 7-12
OFF	OFF	Cycles with DH from ABC board

ABC SW2 Accessory Relay		
DESCRIPTION	SW2-4	SW2-5
Cycle with Blower	ON	ON
Cycle with Compressor	OFF	OFF
Water Valve Slow Opening	ON	OFF
Cycle with Comm. T-stat Hum Cmd	OFF	ON

- Notes
- 1 - Switch blue and red wires for 208V operation.
 - 2 - The blk/wh and gray/wh wires are removed when Aux Heat is installed
 - 3 - When Auxiliary Heat is field installed the harness will then be connected to the auxiliary heat unit. The auxiliary heat unit will then power the blower. Refer to EAS/EAMEAL Auxiliary Heat kit installation instructions.
 - 4 - Low voltage wiring CLASS 2.
 - 5 - Brown blower power wire routed through Current Transducer two times.
 - 6 - Field Connected; Refer to Installation Manual and Auxiliary Heat Instructions for Current Transducer installation.
 - 7 - Wires provided for Auxiliary Heat low voltage control. Wires are secured at blower.

Wiring Schematics cont.

Aurora Advanced with ECM and IntelliStart cont.

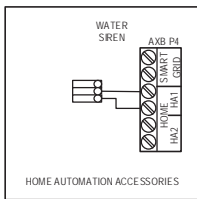
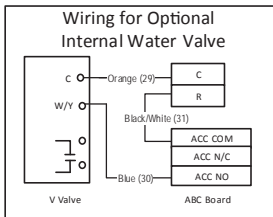
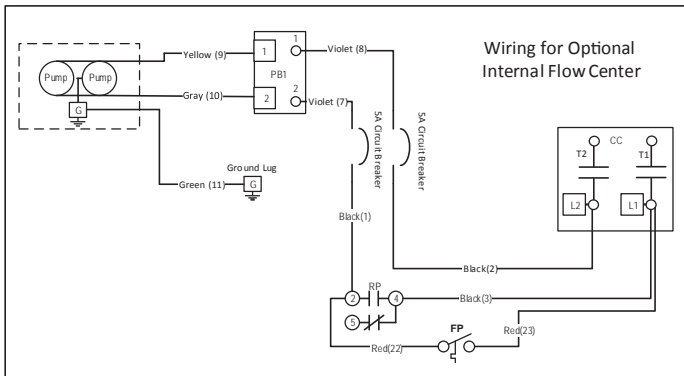
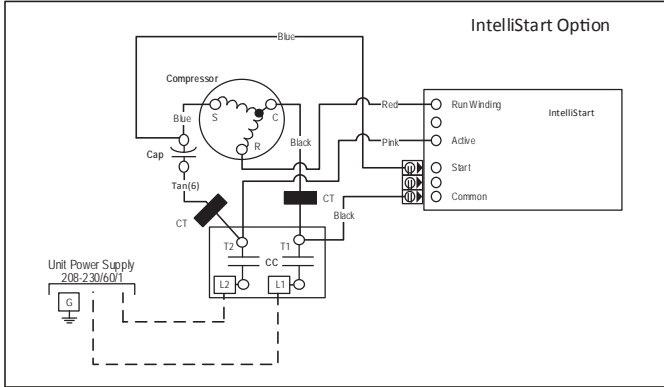

Legend

	Factory Low voltage wiring		Thermistor
	Factory Line voltage wiring		Light emitting diode - Green
	Field low voltage wiring		Relay coil
	Field line voltage wiring		Capacitor w/ bleed resistor
	Optional block		Switch - Condensate overflow
	DC Voltage PCB traces		Switch - High pressure
	Junction		Switch - Low pressure
	Quick connect terminal		Polarized connector
	Wire nut		Current Transducer (CT)
	Field wire lug		
	Ground		
	Relay Contacts- N.O., N.C.		
	Fuse		
	Breaker		

CC - Compressor Contactor	PB1, PB2 - Power blocks
CO - Condensate overflow sensor	PS - Power strip
KS - DHW pump relay	RV - Reversing Valve coil
K6 - Loop pump relay	SW1 - DIP package 5 position AXB
CR3 - PSC Fan Speed Relay	SW1 - TEST MODE ABC Board
CR4 - PSC Fan Power Relay	SW2 - DIP package 8 position ABC Board
CS - Compressor Solenoid	
F1 and F2 - Fuses	TS - Thermal limit switch
HE - Heater element	HWL - Hot water limit sensor
HP - High pressure switch	SC - Start Contactor
ER1 to ER4 - Auk heat stage relays	SR - Start Relay
LP - Low pressure switch	WCL - Water Coil Limit Sensor

Unit Startup

Before Powering Unit, Check the Following:

NOTE: Remove and discard the compressor hold down shipping bolt located at the front of the compressor mounting bracket.

- **Black/white and gray/white wires in unit control box have been removed if auxiliary heat has been installed.**
- **Dip switches are set correctly.**
- **Transformer switched to 208V if applicable.**
- **High voltage is correct and matches nameplate.**
- Fuses, breakers and wire size correct.
- Low voltage wiring complete.
- Piping completed and water system cleaned and flushed.
- Air is purged from closed loop system.
- Isolation valves are open.
- Condensate line trapped, open and correctly pitched.
- Blower rotates freely.
- Blower speed is correct.
- Field-installed air filter/cleaner is clean and in position.
- Service/access panels are in place.
- Return air temperature is between 50-80°F heating and 60-95°F cooling.
- Check air coil cleanliness to ensure optimum performance. Clean as needed according to maintenance guidelines. To obtain maximum performance the air coil should be cleaned before startup. A 10% solution of dishwasher detergent and water is recommended for both sides of coil, a thorough water rinse should follow.

Powering The Controls

Initial Configuration of the Unit

Before operating the unit, apply power and complete the following Aurora Startup procedure for the controls configuration. An AID Tool is recommended for setup, configuration and troubleshooting, especially with an Aurora 'Advanced' Control. AID Tool version 2.04 or greater is preferred.

1. Configure Aurora Screen

- a. In advanced controls - Confirm AXB is added and communicating.
- b. If used confirm communicating thermostats are added and communicating. Set thermostat mode to off.
- c. In advanced controls - Confirm IntelliZone2, if installed, is added and communicating. Set Zoning system to off mode.

2. Aurora Setup Screen

- a. ECM Setup for Heating Airflow - select "G", low, high and aux blower speeds as appropriate for the unit and electric heat.
- b. Cooling Airflow % - sets the cooling airflow % from heating airflow. Factory setting is -15%.
- c. Sensor Kit Setup

- i. Brine Selection - for HE/HR capacity calculation
 - ii. Flow Meter - activates the flow meter
 - iii. Select blower energy - ECM
 - iv. Activate energy option
 - v. Fan and Aux heat current sensor activation
 - vi. Line Voltage calibration - Voltmeter required to calibrate line voltage during heating or cooling. Refer to Line Voltage Calibration in this manual for more details.
- d. Smart Grid Setup - Select Action option for utility received on-peak signal
- e. Home Automation 1 & 2 Setup - Select type of sensor for two home automation inputs.

Configuring the Sensor Kits

Configuring the Sensor kits

The Aurora Advanced Control allows Refrigeration, Energy, and Performance Monitoring sensor kits. These kits can be factory or field installed. The following description is for field activation of a factory installation of the sensor kits.

Energy Monitoring (Standard Sensor Kit on 'Advanced' models)

The Energy Monitoring Kit includes two current transducers (fan and electric heat) added to the existing two compressor sensors so that the complete power usage of the heat pump can be measured. The AID Tool provides configuration detail for the type of blower motor, a line voltage calibration procedure to improve the accuracy, and a power adjustment setting that allows the compressor power to be adjusted to match the unit's line voltage using the provided tables. This information can be displayed on the AID Tool, selected communicating thermostats, or Symphony (if available). The TPCM32U03*/O4* will display instantaneous energy use while the color touchscreen TPCC32U01* will in addition display a 13 month history in graph form. Ensure the Energy Kit has been enabled by accessing the 'Sensor Kit Setup' in the AID Tool and complete the following:

- a. Select 'Blower Energy' - ECM/5-Speed ECM
- b. Activate 'Energy Option' to activate the sensors on for compressor (2), fan and aux heat current sensor.
- c. Select 'Pump' option of FC1, FC2, or open loop. This selects the pump watts used in the calculation. Pump watts are not measured but estimated.
- d. Line Voltage Calibration - Voltmeter required to calibrate line voltage during heating or cooling. Refer to Line Voltage Calibration in this manual for more details.
 - i. Turn on Unit in Heating or Cooling .
 - ii. Use multimeter at L1 and L2 to measure line voltage

Unit Startup cont.

- iii. In the Sensor Kit Setup screen adjust the 'Base Voltage' to the nearest value to that is measured
- iv. Then use the 'Fine Adjust' to select the exact voltage being measured at L1 and L2.
- v. Exit 'Sensor Setup' Screen
- e. Power Adjustment: Refer to the Dual Capacity Power Adjustment tables in the Aurora 'Advanced' Control section of the literature
 - i. On the Main Menu screen select Setup
 - ii. Once in the Setup menu select the Power Adjustment Factor
 - iii. Power Adjustment - allows you to enter the unit's compressor power setting for high and low speed operation. Refer to the tables and use the voltage that is closest to the unit's line voltage and set the power adjustment accordingly.
- f. Energy monitoring can be read on any of the following components:
 - i. AID Tool - instantaneous information only
 - ii. TPCM32U03*/04* Communicating Thermostat (B/W) - instantaneous information only
 - iii. TPCC32U01* Color Touchscreen Thermostat - Both Instantaneously and historical (13 months)
 - iv. Web Portal via AWL device connected to Aurora (if available)

Refrigerant Monitoring (optional sensor kit)

The optional Refrigerant Monitoring Kit includes two pressure transducers, and three temperature sensors, heating liquid line, suction temperature and existing cooling liquid line (FP1). These sensors allow the measurement of discharge and suction pressures, suction and liquid line temperatures as well as superheat and subcooling. This information will only be displayed on the AID Tool. Ensure the Refrigerant Monitoring has been setup by accessing the 'Sensor Kit Setup' in the AID Tool and complete the following:

Once sensors are installed for discharge pressure, suction pressure, suction, liquid line cooling, liquid line heating and leaving air temperature no further setup is required.

- a. Turn on Unit in Heating or Cooling .
- b. Use the AID Tool to view the refrigerant performance in the 'Refrigerant Monitor' screen.
- c. Refrigerant monitoring can be read on any of the following components:
 - i. AID Tool - instantaneous information only
 - ii. Symphony Portal via AWL device connected to Aurora (if available)

Performance Monitoring (optional sensor kit)

The optional Performance Monitoring Kit includes three temperature sensors, entering and leaving water, leaving air temperature and a water flow rate sensor. With this kit heat of extraction and rejection will be calculated. This requires configuration using the AID Tool for selection of water or antifreeze. Ensure the Energy Kit has been enabled by accessing the 'Sensor Kit Setup' in the AID Tool and complete the following:

- a. Select 'Brine' - and then choose Water or Antifreeze for the proper factor
- b. Activate 'Flowmeter' to activate the flow sensor select the appropriate 3/4 in. (026 models), 1 in. (038-072 models), or none.
- c. Exit Sensor Kit Setup Screen
- d. Turn on Unit in Heating or Cooling .
- e. Use the AID Tool to view the performance in the 'Performance Monitor' screen.
- f. Performance monitoring can be read on any of the following components:
 - i. AID tool - instantaneous information only
 - ii. Symphony Web Portal via AWL device connected to Aurora. (if available)

Startup Steps

NOTE: Complete the Equipment Start-Up/Commissioning Check Sheet during this procedure. Refer to thermostat operating instructions and complete the startup procedure. Verify that the compressor shipping bolt has been removed.

1. Initiate a control signal to energize the blower motor. Check blower operation through the AID Tool.
2. Initiate a control signal to place the unit in the cooling mode. Cooling setpoint must be set below room temperature.
3. First stage cooling will energize after a time delay.
4. Be sure that the compressor and water control valve or loop pump(s) are activated.
5. Verify that the water flow rate is correct by measuring the pressure drop through the heat exchanger using the P/T plugs and comparing to unit performance data in catalog.
6. Check the temperature of both the supply and discharge water (see the Unit Operating Parameters tables).
7. Check for an air temperature drop of 15°F to 25°F across the air coil, depending on the fan speed and entering water temperature.
8. Decrease the cooling set point several degrees and verify high-speed blower operation.
9. Adjust the cooling setpoint above the room temperature and verify that the compressor and water valve or loop pumps deactivate.
10. Initiate a control signal to place the unit in the heating mode. Heating set point must be set above room temperature.
11. First stage heating will energize after a time delay.
12. Check the temperature of both the supply and discharge water (see the Unit Operating Parameters tables).
13. Check for an air temperature rise of 12°F to 35°F across the air coil, depending on the fan speed and entering water temperature.

Unit Startup cont.

14. If auxiliary electric heaters are installed, increase the heating setpoint until the electric heat banks are sequenced on. All stages of the auxiliary heater should be sequenced on when the thermostat is in the Emergency Heat mode. Check amperage of each element.
15. Adjust the heating setpoint below room temperature and verify that the compressor and water valve or loop pumps deactivate.
16. During all testing, check for excessive vibration, noise or water leaks. Correct or repair as required.
17. Set system to desired normal operating mode and set temperature to maintain desired comfort level.
18. Instruct the owner/operator in the proper operation of the thermostat and system maintenance.

NOTE: Be certain to fill out and forward all warranty registration papers.

Antifreeze Corrections

Catalog performance can be corrected for antifreeze use. Please use the following table and note the example given.

Antifreeze Type	Antifreeze % by wt	Heating	Cooling	Pressure Drop
EWT - °F [°C]		30 [-1.1]	90 [32.2]	30 [-1.1]
Water	0	1.000	1.000	1.000
Ethylene Glycol	10	0.973	0.991	1.075
	20	0.943	0.979	1.163
	30	0.917	0.965	1.225
	40	0.890	0.955	1.324
	50	0.865	0.943	1.419
Propylene Glycol	10	0.958	0.981	1.130
	20	0.913	0.969	1.270
	30	0.854	0.950	1.433
	40	0.813	0.937	1.614
	50	0.770	0.922	1.816
Ethanol	10	0.927	0.991	1.242
	20	0.887	0.972	1.343
	30	0.856	0.947	1.383
	40	0.815	0.930	1.523
	50	0.779	0.911	1.639
Methanol	10	0.957	0.986	1.127
	20	0.924	0.970	1.197
	30	0.895	0.951	1.235
	40	0.863	0.936	1.323
	50	0.833	0.920	1.399



WARNING: Gray area represents antifreeze concentrations greater than 35% by weight and should be avoided due to the extreme performance penalty they represent.

Antifreeze Correction Example

Antifreeze solution is Propylene Glycol 20% by weight. Determine the corrected heating and cooling performance at 30°F and 90°F respectively as well as pressure drop at 30°F for the O26 Full Load.

The corrected cooling capacity at 90°F would be: 22,500 MBtu/h x 0.969 = 21,803 MBtu/h

The corrected heating capacity at 30°F would be: 18,700 MBtu/h x 0.913 = 17,073 MBtu/h

The corrected pressure drop at 30°F and 8 gpm would be: 10.8 feet of head x 1.270 = 13.7 feet of head

Correction Factor Tables

Air Flow Corrections (Dual Capacity Part Load)

Airflow		Cooling				Heating		
cfm Per Ton of Clg	% of Nominal	Total Cap	Sens Cap	Power	Heat of Rej	Htg Cap	Power	Heat of Ext
240	60	0.922	0.778	0.956	0.924	0.943	1.239	0.879
275	69	0.944	0.830	0.962	0.944	0.958	1.161	0.914
300	75	0.957	0.866	0.968	0.958	0.968	1.115	0.937
325	81	0.970	0.900	0.974	0.970	0.977	1.075	0.956
350	88	0.982	0.933	0.981	0.980	0.985	1.042	0.972
375	94	0.991	0.968	0.991	0.991	0.993	1.018	0.988
400	100	1.000	1.000	1.000	1.000	1.000	1.000	1.000
425	106	1.007	1.033	1.011	1.008	1.007	0.990	1.010
450	113	1.013	1.065	1.023	1.015	1.012	0.987	1.018
475	119	1.017	1.099	1.037	1.022	1.018	0.984	1.025
500	125	1.020	1.132	1.052	1.027	1.022	0.982	1.031
520	130	1.022	1.159	1.064	1.030	1.025	0.979	1.034

5/30/06

Air Flow Corrections (Dual Capacity Full Load)

Airflow		Cooling				Heating		
cfm Per Ton of Clg	% of Nominal	Total Cap	Sens Cap	Power	Heat of Rej	Htg Cap	Power	Heat of Ext
240	60	0.922	0.786	0.910	0.920	0.943	1.150	0.893
275	69	0.944	0.827	0.924	0.940	0.958	1.105	0.922
300	75	0.959	0.860	0.937	0.955	0.968	1.078	0.942
325	81	0.971	0.894	0.950	0.967	0.977	1.053	0.959
350	88	0.982	0.929	0.964	0.978	0.985	1.031	0.973
375	94	0.992	0.965	0.982	0.990	0.993	1.014	0.988
400	100	1.000	1.000	1.000	1.000	1.000	1.000	1.000
425	106	1.007	1.034	1.020	1.010	1.007	0.990	1.011
450	113	1.012	1.065	1.042	1.018	1.013	0.983	1.020
475	119	1.017	1.093	1.066	1.026	1.018	0.980	1.028
500	125	1.019	1.117	1.092	1.033	1.023	0.978	1.034
520	130	1.020	1.132	1.113	1.038	1.026	0.975	1.038

5/30/06

Cooling Capacity Corrections

Entering Air WB °F	Total Clg Cap	Sensible Cooling Capacity Multipliers - Entering DB °F										Power Input	Heat of Rejection
		60	65	70	75	80	80.6	85	90	95	100		
55	0.898	0.723	0.866	1.048	1.185	*	*	*	*	*	*	0.985	0.913
60	0.912		0.632	0.880	1.078	1.244	1.260	*	*	*	*	0.994	0.927
63	0.945			0.768	0.960	1.150	1.175	*	*	*	*	0.996	0.954
65	0.976			0.694	0.881	1.079	1.085	1.270	*	*	*	0.997	0.972
66.2	0.983			0.655	0.842	1.040	1.060	1.232	*	*	*	0.999	0.986
67	1.000			0.616	0.806	1.000	1.023	1.193	1.330	1.480	*	1.000	1.000
70	1.053				0.693	0.879	0.900	1.075	1.205	1.404	*	1.003	1.044
75	1.168					0.687	0.715	0.875	1.040	1.261	1.476	1.007	1.141

NOTE: * Sensible capacity equals total capacity at conditions shown.

3/28/12

Heating Capacity Corrections

Ent Air DB °F	Heating Corrections		
	Htg Cap	Power	Heat of Ext
45	1.062	0.739	1.158
50	1.050	0.790	1.130
55	1.037	0.842	1.096
60	1.025	0.893	1.064
65	1.012	0.945	1.030
68	1.005	0.976	1.012
70	1.000	1.000	1.000
75	0.987	1.048	0.970
80	0.975	1.099	0.930

11/10/09

Operating Parameters

Dual Capacity Models

First Stage Operation

Entering Water Temp °F	Water Flow gpm/ton	Cooling -- No Hot Water Generation					
		Suction Pressure psig	Discharge Pressure psig	Superheat	Subcooling	Water Temp Rise °F	Air Temp Drop °F DB
30	1.5						
	3.0	107 - 123	125 - 145	20 - 40	3 - 14	6 - 10	15 - 22
50	1.5	143 - 158	205 - 230	10 - 20	3 - 10	16 - 20	16 - 23
	3.0	138 - 153	180 - 205	10 - 20	3 - 10	7 - 11	16 - 23
70	1.5	145 - 160	270 - 300	8 - 20	3 - 10	16 - 20	16 - 22
	3.0	140 - 155	245 - 270	8 - 20	3 - 10	7 - 11	16 - 22
90	1.5	147 - 162	335 - 370	7 - 15	3 - 10	14 - 20	16 - 22
	3.0	142 - 158	320 - 355	7 - 15	3 - 10	7 - 11	16 - 22
110	1.5						
	3.0	148 - 165	410 - 440	7 - 12	3 - 10	6 - 10	15 - 21
120	1.5						
	3.0	152 - 170	465 - 500	6 - 14	3 - 10	6 - 10	15 - 21

Entering Water Temp °F	Water Flow gpm/ton	Heating -- No Hot Water Generation					
		Suction Pressure psig	Discharge Pressure psig	Superheat	Subcooling	Water Temp Drop °F	Air Temp Rise °F DB
20	1.5						
	3.0	65 - 76	260 - 300	7 - 14	3 - 10	3 - 7	13 - 19
30	1.5	75 - 86	265 - 310	7 - 15	3 - 10	5 - 9	12 - 21
	3.0	79 - 90	270 - 320	7 - 15	3 - 10	3 - 7	14 - 23
50	1.5	103 - 118	285 - 345	10 - 14	3 - 10	6 - 10	16 - 26
	3.0	108 - 123	295 - 350	10 - 14	3 - 10	4 - 8	18 - 28
70	1.5	140 - 155	310 - 385	12 - 16	3 - 15	7 - 11	20 - 23
	3.0	145 - 160	315 - 390	12 - 16	3 - 15	5 - 9	22 - 35
90	1.5	178 - 193	330 - 410	12 - 18	3 - 18	8 - 12	22 - 38
	3.0	183 - 198	340 - 430	12 - 18	3 - 18	6 - 10	24 - 40
110	1.5						
	3.0						

Note: Cooling performance based on rated cfm and entering air temperatures of 80° F DB, 67° F WB.
Heating performance based on rated cfm and entering air temperature of 70° F DB.

7/31/2017

Second Stage Operation

Entering Water Temp °F	Water Flow gpm/ton	Cooling -- No Hot Water Generation					
		Suction Pressure psig	Discharge Pressure psig	Superheat	Subcooling	Water Temp Rise °F	Air Temp Drop °F DB
30	1.5	110 - 125	150 - 180	20 - 35	10 - 17	17 - 22	17 - 23
	3.0	100 - 120	130 - 155	20 - 35	8 - 17	7 - 10	17 - 23
50	1.5	130 - 140	215 - 240	12 - 25	8 - 14	16 - 22	17 - 23
	3.0	128 - 138	190 - 220	12 - 25	5 - 14	8 - 12	17 - 23
70	1.5	138 - 148	280 - 315	10 - 16	10 - 16	15 - 21	17 - 23
	3.0	136 - 146	250 - 285	9 - 16	6 - 14	7 - 13	17 - 23
90	1.5	142 - 155	350 - 390	7 - 14	9 - 16	14 - 20	15 - 21
	3.0	140 - 153	320 - 365	7 - 14	6 - 14	6 - 10	15 - 21
110	1.5						
	3.0	142 - 155	415 - 460	6 - 14	7 - 14	6 - 10	15 - 21
120	1.5						
	3.0	143 - 157	475 - 515	6 - 14	7 - 14	6 - 10	15 - 21

Entering Water Temp °F	Water Flow gpm/ton	Heating -- No Hot Water Generation					
		Suction Pressure psig	Discharge Pressure psig	Superheat	Subcooling	Water Temp Drop °F	Air Temp Rise °F DB
20	1.5						
	3.0	62 - 74	270 - 305	7 - 15	3 - 14	3 - 8	15 - 20
30	1.5						
	3.0	76 - 88	280 - 320	7 - 15	3 - 16	3 - 8	16 - 22
50	1.5	103 - 116	290 - 335	10 - 16	5 - 18	7 - 11	21 - 31
	3.0	105 - 121	305 - 350	10 - 16	5 - 18	5 - 10	22 - 33
70	1.5	137 - 152	320 - 380	11 - 17	5 - 20	9 - 13	23 - 38
	3.0	142 - 157	330 - 395	11 - 17	5 - 20	6 - 11	25 - 40
90	1.5	165 - 190	350 - 430	13 - 20	5 - 20	10 - 14	30 - 43
	3.0	170 - 196	365 - 445	13 - 20	5 - 20	7 - 12	30 - 45
110	1.5						
	3.0						

Note: Cooling performance based on rated cfm and entering air temperatures of 80° F DB, 67° F WB.
Heating performance based on rated cfm and entering air temperature of 70° F DB.

7/31/2017

Pressure Drop

Dual Capacity

Model	gpm	Pressure Drop (psi)				
		30°F	50°F	70°F	90°F	110°F
026 full load	4	1.4	1.3	1.2	1.1	1.0
	6	2.8	2.6	2.4	2.3	2.1
	8	4.7	4.4	4.1	3.8	3.5
	10	7.0	6.6	6.2	5.8	5.3
026 part load	3	0.8	0.7	0.7	0.7	0.6
	5	2.0	1.8	1.7	1.6	1.5
	7	3.6	3.4	3.2	3.0	2.8
	9	5.8	5.5	5.1	4.8	4.4
038 full load	5	1.2	1.2	1.1	1.0	1.0
	7	2.2	2.1	1.9	1.8	1.7
	9	3.4	3.2	3.0	2.8	2.6
	11	4.9	4.6	4.3	4	3.7
038 part load	4	0.9	0.8	0.8	0.7	0.7
	6	1.7	1.6	1.5	1.4	1.3
	8	2.8	2.6	2.5	2.3	2.1
	10	4.2	3.9	3.7	3.4	3.2
049 full load	6	1.2	1.2	1.1	1.0	1.0
	9	2.4	2.2	2.1	2.0	1.8
	12	3.9	3.6	3.4	3.2	2.9
	15	5.7	5.3	5	4.7	4.3
049 part load	5	0.9	0.9	0.8	0.8	0.7
	8	2.0	1.8	1.7	1.6	1.5
	11	3.4	3.1	2.9	2.8	2.5
	14	5.0	4.7	4.4	4.1	3.8
064 full load	8	1.8	1.7	1.6	1.4	1.3
	12	3.8	3.5	3.3	3.0	2.8
	16	6.5	6.0	5.6	5.2	4.8
	20	9.7	9.1	8.5	8.0	7.4
064 part load	6	1.0	0.9	0.9	0.8	0.8
	10	2.6	2.5	2.3	2.1	2.0
	14	5.0	4.7	4.4	4.1	3.8
	18	8.1	7.6	7.1	6.6	6.1
072 full load	12	3.2	3.0	2.8	2.6	2.4
	15	4.5	4.2	4.0	3.7	3.4
	18	6.0	5.7	5.3	4.9	4.6
	21	7.8	7.3	6.8	6.4	5.9
072 part load	10	2.3	2.1	2.0	1.9	1.7
	13	3.6	3.3	3.0	2.8	2.6
	16	5.0	4.6	4.3	4.0	3.7
	19	6.5	6.2	5.8	5.4	5.0

1/26/12

Compressor Resistance

Model	Compressor Model No.	208-230/60/1	
		Run	Start
026	ZPS20K5E-PFV	1.21 - 1.39	1.52 - 1.75
038	ZPS30K5E-PFV	0.81 - 0.94	1.41 - 1.63
049	ZPS40K5E-PFV	0.48 - 0.55	1.72 - 1.99
064	ZPS51K5E-PFV	0.36 - 0.42	1.51 - 1.74
072	ZPS60K5E-PFV	0.31 - 0.36	1.72 - 1.98

NOTE: Resistance at 77°F

2/7/12

Thermistor Resistance

Thermistor Temperature (°F)	Microprocessor Resistance (Ohms)
5	75757-70117
14	57392-53234
23	43865-40771
32	33809-31487
41	26269-24513
50	20570-19230
59	16226-15196
68	12889-12093
77	10310-9688
86	8300-7812
95	6723-6337
104	5480-5172
113	4490-4246
122	3700-3504
131	3067-2907
140	2554-2424
149	2149-2019

2/8/12

Refrigerant Circuit Guideline

Symptom	Head Pressure	Suction Pressure	Compressor Amp Draw	Superheat	Subcooling	Air Temp. Differential	Water Temp. Differential
Under Charged System (Possible Leak)	Low	Low	Low	High	Low	Low	Low
Over Charged System	High	High	High	Normal	High	Normal/Low	Normal
Low Air Flow Heating	High	High	High	High/Normal	Low	High	Low
Low Air Flow Cooling	Low	Low	Low	Low/Normal	High	High	Low
Low Water Flow Heating	Low/Normal	Low/Normal	Low	Low	High	Low	High
Low Water Flow Cooling	High	High	High	High	Low	Low	High
High Air Flow Heating	Low	Low	Low	Low	High	Low	Low
High Air Flow Cooling	Low	High	Normal	High	Low	Low	Normal
High Water Flow Heating	Normal	Low	Normal	High	Normal	Normal	Low
High Water Flow Cooling	Low	Low	Low	Low	High	Normal	Low
Low Indoor Air Temperature Heating	Low	Low	Low	Normal	High	Normal	Normal/High
Low Indoor Air Temperature Cooling	Low	Low	Low	Normal/Low	High	Low	Low
High Indoor Air Temperature Heating	High	High	High	Normal/High	Normal/Low	Low	Normal
High Indoor Air Temperature Cooling	High	High	High	High	Low	Low	High
Restricted TXV (Check Service Advisory)	High	Low	Normal/Low	High	High	Low	Low
Insufficient Compressor (Possible Bad Valves)	Low	High	Low	High	Normal/High	Low	Low
TXV - Bulb Loss of Charge	Low	Low	Low	High	High	Low	Low
Scaled Coaxial Heat Exchanger Heating	Low	Low	Low	Normal/Low	High	Low	Low
Scaled Coaxial Heat Exchanger Cooling	High	High	High	Normal/Low	Low	Low	Low
Restricted Filter Drier	Check temperature difference (delta T) across filter drier.						

7/6/10

Heat of Extraction/Rejection

Dual Capacity

Model		GPM	Heat of Extraction (kBtuh)				Heat of Rejection (kBtuh)				
			30°F	50°F	70°F	90°F	30°F	50°F	70°F	90°F	110°F
026	Part Load	3.0		12.8	10.8	14.7		22.8	21.4	20.3	
		5.0	9.2	13.3	11.3	15.4	20.9	22.9	21.5	20.4	19.6
		7.0	9.9	14.1	12.0	16.0	21.1	23.2	21.7	20.6	19.8
	Full Load	4.0		17.6	22.1	27.0		31.1	29.2	27.6	
		6.0	13.3	18.4	23.3	28.8	26.9	31.4	29.6	28.1	27.1
		8.0	13.6	18.8	24.0	29.8	27.1	31.6	29.8	28.2	27.2
038	Part Load	4.0		16.3	22.1	28.8		34.2	31.5	30.5	
		6.0	11.8	17.0	23.3	30.6	26.5	34.4	31.7	30.6	28.8
		8.0	12.8	17.9	23.9	30.6	26.7	34.9	32.1	31.0	29.1
	Full Load	5.0		23.8	30.4	35.8		44.6	44.5	41.6	
		7.0	18.8	24.9	32.0	38.3	37.6	45.0	45.1	42.4	41.3
		9.0	19.2	25.5	33.0	39.6	37.9	45.3	45.4	42.7	41.4
049	Part Load	5.0		23.4	28.9	34.3		45.0	44.8	41.9	
		8.0	17.9	25.9	31.9	38.2	38.1	45.1	44.5	41.3	38.7
		3.0	18.6	26.8	33.6	40.6	38.5	45.1	44.8	42.1	39.6
	Full Load	6.0		33.2	41.7	49.5		62.6	61.7	58.2	
		9.0	27.9	36.6	46.1	55.1	53.2	62.5	61.2	57.4	54.3
		12.0	28.9	38.0	48.6	58.7	53.6	62.4	61.6	58.4	55.6
064	Part Load	6.0		30.4	40.2	47.9		57.8	53.3	49.3	
		10.0	20.5	30.8	41.9	51.6	42.5	57.6	53.3	49.6	46.1
		14.0	21.5	31.9	42.7	51.7	47.8	57.7	53.4	49.8	46.4
	Full Load	8.0		42.8	55.6	67.4		76.6	73.3	70.3	
		12.0	34.7	45.8	58.0	68.5	67.5	77.0	73.8	70.5	66.0
		18.0	35.1	46.7	59.8	71.3	68.0	77.5	74.1	70.9	66.1
072	Part Load	10.0		40.5	51.8	62.3		67.4	63.3	60.6	
		15.0	28.3	40.8	54.1	67.2	57.6	67.3	63.3	60.8	57.8
		18.0	30.0	42.5	55.0	67.3	58.1	67.2	63.6	61.1	58.1
	Full Load	12.0		53.1	67.3	83.6		85.7	85.3	82.1	
		15.0	42.1	56.7	70.1	84.9	77.1	86.1	85.7	82.3	78.1
		18.0	42.5	57.8	72.3	88.4	77.6	86.7	86.2	82.7	78.3

Note: operation not recommended in shaded areas.

7/19/2017

Troubleshooting

Aurora Control System

NOTE: Refer to the Aurora Base Control Application and Troubleshooting Guide and the Instruction Guide: Aurora Interface and Diagnostics (AID) Tool for additional information.

To check the unit control board for proper operation:

1. Disconnect thermostat wires at the control board.
2. Jumper the desired test input (Y1, Y2, W, O or G) to the R terminal to simulate a thermostat signal.
3. If control functions properly:
 - Check for thermostat and field control wiring (use the diagnostic inputs mode).
4. If control responds improperly:
 - Ensure that component being controlled is functioning (compressor, blower, reversing valve, etc.).
 - Ensure that wiring from control to the component is correct.
 - Refer to the Aurora Base Control Application and Troubleshooting Guide and the Instruction Guide: Aurora Interface and Diagnostics (AID) Tool for additional information.

Refrigerant Systems

To maintain sealed circuit integrity, do not install service gauges unless unit operation appears abnormal. Compare the change in temperature on the air side as well as the water side to the Unit Operating Parameters tables. If the unit's performance is not within the ranges listed, and the airflow and water flow are known to be correct, gauges should then be installed and superheat and subcooling numbers calculated. If superheat and subcooling are outside recommended ranges, an adjustment to the refrigerant charge may be necessary.

Troubleshooting cont.

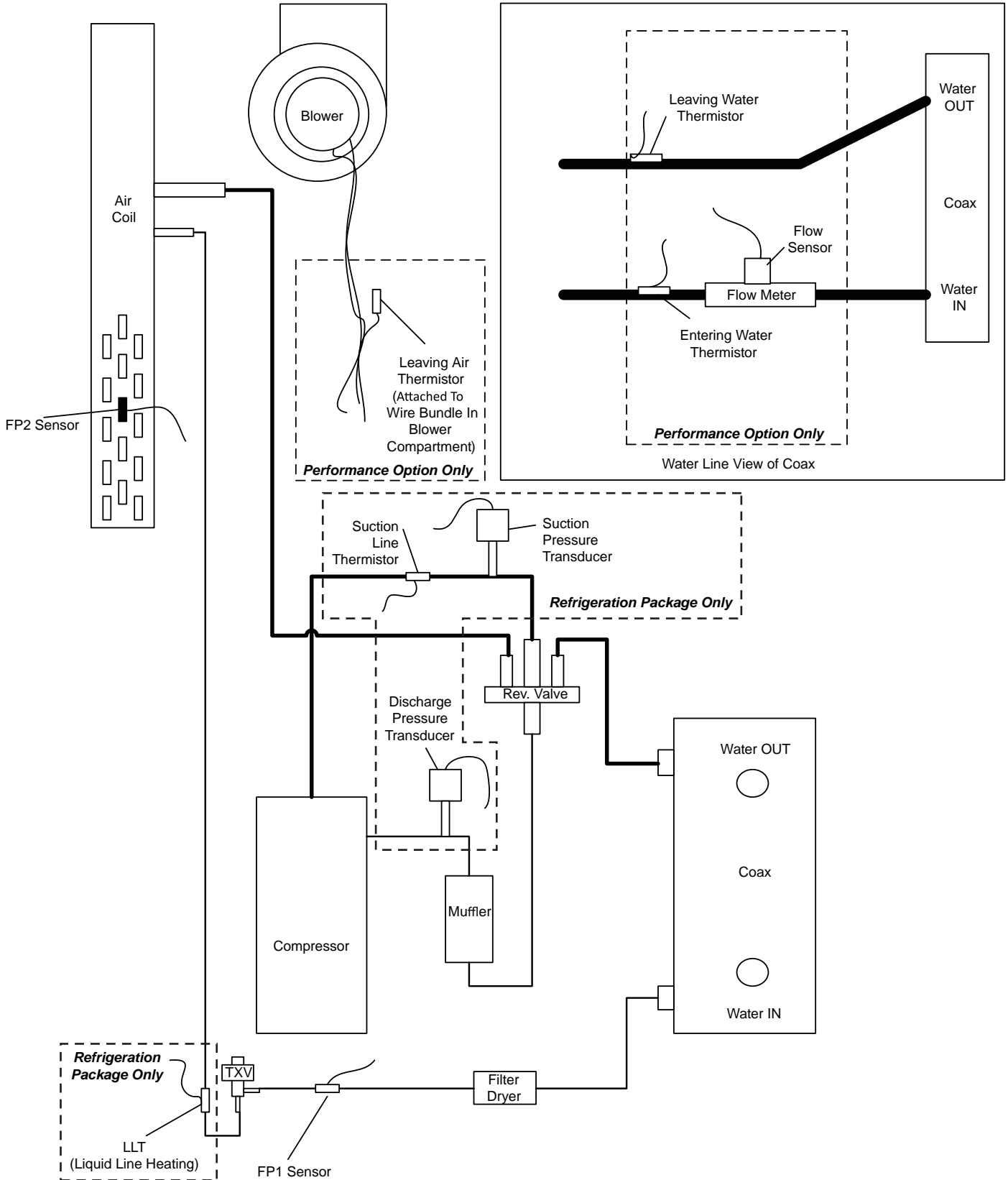

Startup/Troubleshooting Form

Dealer: _____
 Phone #: _____ Date: _____
 Problem: _____
 Model #: _____
 Serial #: _____

Controls Info:
 ABC Version: _____
 AXB Version: _____
 IZ2 Version: _____
 T-Stat Version: _____
 Installed Sensors: _____

COOLING CYCLE ANALYSIS

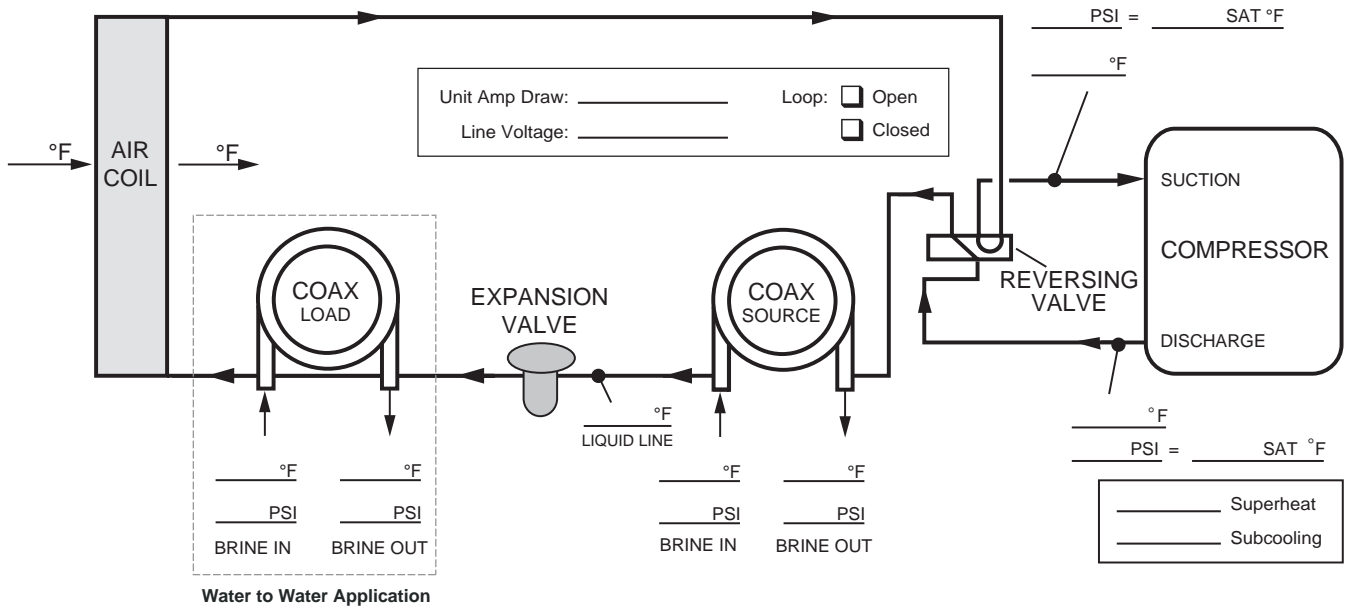

$$\text{Heat of Extraction/Rejection} = \text{gpm} \times 500 \text{ (485 for water/antifreeze)} \times \Delta T$$

Note: DO NOT hook up pressure gauges unless there appears to be a performance problem.

HEATING CYCLE ANALYSIS

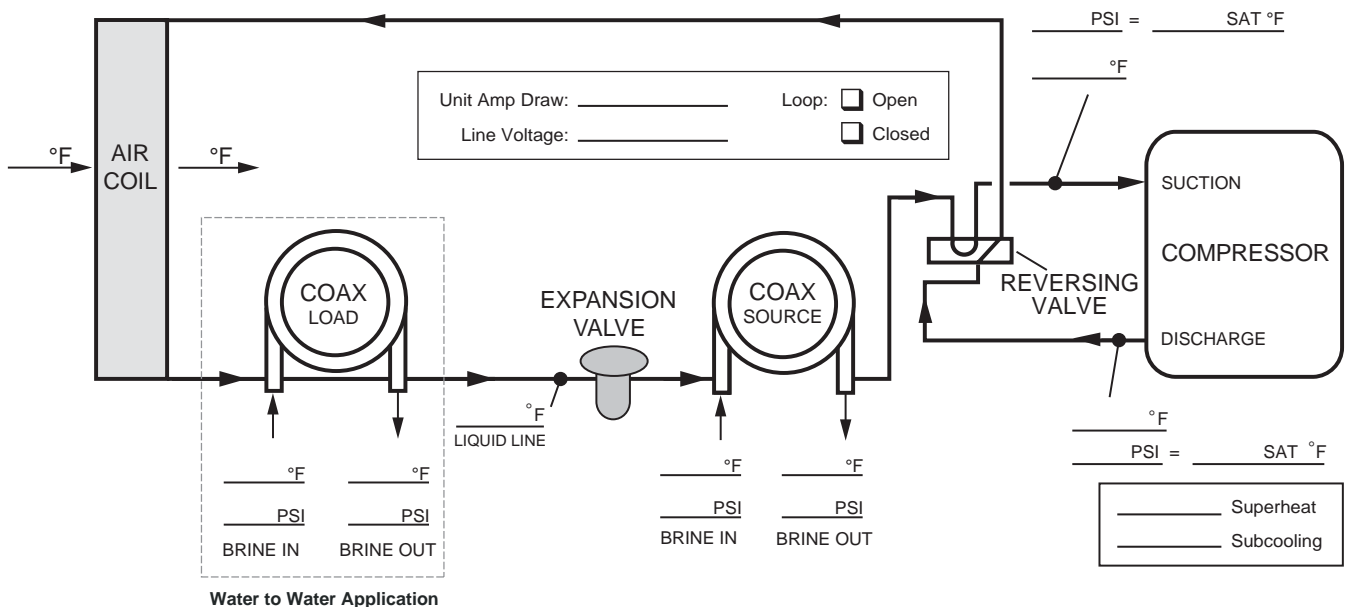

Troubleshooting cont.

Single Speed/Dual Capacity Startup/Troubleshooting Form

1. Job Information

Model # _____ Job Name: _____ Loop: Open / Closed
 Serial # _____ Install Date: _____ Hot Water Generator: Y / N

2. Flow Rate in gpm

	SOURCE COAX		LOAD COAX (Water-to-Water)	
	HEATING	COOLING	HEATING	COOLING
WATER IN Pressure:	a. _____ psi	a. _____ psi	a. _____ psi	a. _____ psi
WATER OUT Pressure:	b. _____ psi	b. _____ psi	b. _____ psi	b. _____ psi
Pressure Drop: a - b	c. _____ psi	c. _____ psi	c. _____ psi	c. _____ psi
Look up flow rate in table:	d. _____ gpm	d. _____ gpm	d. _____ gpm	d. _____ gpm

3. Temp. Rise/Drop Across Air Coil¹

	HEATING	COOLING
SUPPLY AIR Temperature:	e. _____ °F	e. _____ °F
RETURN AIR Temperature:	f. _____ °F	f. _____ °F
Temperature Difference:	g. _____ °F	g. _____ °F

4. Temp. Rise/Drop Across Coaxial Heat Exchanger

	SOURCE COAX		LOAD COAX (Water-to-Water)	
	HEATING	COOLING	HEATING	COOLING
WATER IN Temperature:	h. _____ °F	h. _____ °F	h. _____ °F	h. _____ °F
WATER OUT Temperature:	i. _____ °F	i. _____ °F	i. _____ °F	i. _____ °F
Temperature Difference:	j. _____ °F	j. _____ °F	j. _____ °F	j. _____ °F

5. Heat of Rejection (HR)/Heat of Extraction (HE)

Brine Factor²: k. _____

HR/HE = d x g x k

	HEATING	COOLING
	l. _____ Btu/h	l. _____ Btu/h

STEPS 6-9 NEED ONLY BE COMPLETED IF A PROBLEM IS SUSPECTED.

6. Watts

	ENERGY MONITOR	
	HEATING	COOLING
Volts:	m. _____ Volts	m. _____ Volts
Total Amps (Comp. + Blower) ³ :	n. _____ Amps	n. _____ Amps
Watts = m x n x 0.85:	o. _____ Watts	o. _____ Watts

7. Capacity

	HEATING	COOLING
Cooling Capacity = l - (o x 3.413):	p. _____ Btu/h	p. _____ Btu/h
Heating Capacity = l + (o x 3.413):		

8. Efficiency

	HEATING	COOLING
Cooling EER = p / o:	q. _____ Btu/h	q. _____ Btu/h
Heating COP = p / (o x 3.413):		

9. Superheat (S.H.)/Subcooling (S.C.)

	HEATING	COOLING
Suction Pressure:	r. _____ psi	r. _____ psi
Suction Saturation Temperature:	s. _____ °F	s. _____ °F
Suction Line Temperature:	t. _____ °F	t. _____ °F
S.H. = t - s	u. _____ °F	u. _____ °F
Head Pressure:	v. _____ psi	v. _____ psi
High Pressure Saturation Temp:	w. _____ °F	w. _____ °F
Liquid Line Temperature ⁴ :	x. _____ °F	x. _____ °F
S.C. = w - x	y. _____ °F	y. _____ °F

Software Version
ABC: _____
AXB: _____
IZ2: _____
T'STAT: _____

NOTES: ¹ Steps 3-9 should be conducted with the hot water generator disconnected.
² Use 500 for pure water, 485 for methanol or Environol™. (This constant is derived by multiplying the weight of one gallon of water (8.34) times the minutes in one hour (60) times the specific heat of the fluid. Water has a specific heat of 1.0.
³ If there is only one source of power for the compressor and blower, amp draw can be measured at the source wiring connection.
⁴ Liquid line is between the coax and the expansion device in the cooling mode; between the air coil and the expansion device in the heating mode.

Preventive Maintenance

Water Coil Maintenance

1. Keep all air out of the water. An open loop system should be checked to ensure that the well head is not allowing air to infiltrate the water line. Lines should always be airtight.
2. Keep the system under pressure at all times. It is recommended in open loop systems that the water control valve be placed in the discharge line to prevent loss of pressure during off cycles. Closed loop systems must have positive static pressure.

NOTE: On open loop systems, if the installation is in an area with a known high mineral content (125 PPM or greater) in the water, it is best to establish with the owner a periodic maintenance schedule so the coil can be checked regularly. Should periodic coil cleaning be necessary, use standard coil cleaning procedures which are compatible with either the cupronickel or copper water lines. Generally, the more water flowing through the unit the less chance for scaling.

Other Maintenance

Filters

Filters must be clean to obtain maximum performance. They should be inspected monthly under normal operating conditions and be replaced when necessary. Units should never be operated without a filter.

Condensate Drain

In areas where airborne bacteria produce a slime in the drain pan, it may be necessary to treat chemically to minimize the problem. The condensate drain can pick up lint and dirt, especially with dirty filters. Inspect twice a year to avoid the possibility of overflow.

Blower Motors

ECM blower motors are equipped with sealed ball bearings and require no periodic oiling.

Air Coil

The air coil must be cleaned to obtain maximum performance. Check once a year under normal operating conditions and, if dirty, brush or vacuum (with a brush attachment) clean. Care must be taken not to damage the aluminum fins while cleaning.



CAUTION: Fin edges are sharp.

Replacement Procedures

Obtaining Parts

When ordering service or replacement parts, refer to the model number and serial number of the unit as stamped on the serial plate attached to the unit. If replacement parts are required, mention the date of installation of the unit and the date of failure, along with an explanation of the malfunctions and a description of the replacement parts required.

In-Warranty Material Return

Material may not be returned except by permission of authorized warranty personnel. Contact your local distributor for warranty return authorization and assistance.

Service Parts List

Parts List		Dual Capacity Units				
		026	038	049	064	072
Compressor	Compressor 208-230/60/1	34P640-01	34P641-01	34P642-01	34P643-01	34P644-01
	Run Capacitor 208-230/60/1	16P002D19	16P002D20	16P002D18	16P002D31	16P002D31
	Sound Jacket	92P504A16	92P504A16	92P504A16	92P504A16	92P504A16
	Power Harness	11P781-01	11P781-01	11P781-01	11P781-01	11P781-01
	Crankcase Heater	19P535-09	19P535-09	19P535-07	19P535-08	19P535-08
	Solenoid Harness	11P782-02	11P782-02	11P782-02	11P782-02	11P782-02
ECM Motor & Blower	ECM Motor 208-230/60/1	14S565-01	14S564-01	14S557-01	14S557-01	14S557-01
	ECM Motor Module Kit	PMK585	PMK574	PMK572	PMK572	PMK572
	ECM Blower Housing	53P500B01	53P501B01	53P501B01	53P501B01	53P501B01
	ECM Harness	11P827-02	11P827-02	11P827-02	11P827-02	11P827-02
	ECM Power Harness	11P585B04	11P585B04	11P585B04	11P585B04	11P585B04
Refrigeration Components	Air Coil	61P705-41	61P706-41	61P715-41	61P725-41	61P725-41
	Coax	62I566-01	62I574-01	62I543-04	62I543-04	62I557-01
	TXV	33P619-01	33P619-02	33P619-03	33P619-04	33P619-05
	Reversing Valve	33P506-05	33P503-05	33P526-05	33P526-05	33P526-05
	Discharge Muffler	36P503B02	36P503B02	36P503B02	36P503B02	36P503B02
	Filter Dryer	36P500B01	36P500B01	36P500B01	36P500B02	36P500B02
	Contactor	13P004A03	13P004A03	13P004A03	13P004A03	13P004A03
Electrical	Transformer 208-230/60/1	15P501B01	15P501B01	15P501B01	15P501B01	15P501B01
	3 Pole Power Block	12P503-06	12P503-06	12P503-06	12P503-06	12P503-06
	2 Pole Screw Term. Block	12P500A01	12P500A01	12P500A01	12P500A01	12P500A01
	ABC Board	17X553-00	17X553-00	17X553-00	17X553-00	17X553-00
	AXB Board	17P557-01	17P557-01	17P557-01	17P557-01	17P557-01
	ABC/AXB Communication Cable	11P837-01	11P837-01	11P837-01	11P837-01	11P837-01
	Pump Circuit Breaker - 5 amp, 250v	19P583-01	19P583-01	19P583-01	19P583-01	19P583-01
	Thermistor, Low Water Coil Limit (FP1)	12P505-09	12P505-09	12P505-09	12P505-09	12P505-09
Sensors & Safeties	Current Sensors	12P557-01	12P557-01	12P557-01	12P557-01	12P557-01
	Flow Meter Sensor Kit (clip, sensor, harness)	29P536-01	29P535-01	29P535-01	29P535-01	29P535-01
	Thermistor Vertical, Air Coil Freeze Detection (FP2)	12P550-01	12P550-01	12P550-01	12P550-01	12P550-01
	Thermistor, Suction Line	12P555-05	12P555-05	12P555-05	12P555-05	12P555-05
	Thermistor, Liquid Line Heating	12P555-03	12P555-03	12P555-03	12P555-03	12P555-03
	Thermistor, Entering Water	12P555-01	12P555-01	12P555-01	12P555-01	12P555-01
	Thermistor, Leaving Water	12P555-02	12P555-02	12P555-02	12P555-02	12P555-02
	Thermistor, Leaving Air	12P555-06	12P555-06	12P555-06	12P555-06	12P555-06
	High Pressure Transducer Kit	SK5SHPT	SK5SHPT	SK5SHPT	SK5SHPT	SK5SHPT
	Low Pressure Transducer Kit	SK5SLPT	SK5SLPT	SK5SLPT	SK5SLPT	SK5SLPT
	High Pressure Switch	SKHPE600	SKHPE600	SKHPE600	SKHPE600	SKHPE600
	Low Pressure Switch	SKLPE40	SKLPE40	SKLPE40	SKLPE40	SKLPE40
	Low Temperature Sensor	35P505-02	35P505-02	35P505-02	35P505-02	35P505-02

Part numbers subject to change

8/7/17

Notes

Revision Guide

Pages:	Description:	Date:	By:
All	Document Created	23 Nov 2017	JM/MA



Product: **Aston Series**
Type: Geothermal/Water Source Heat Pump
Size: 2-6 Ton Dual Capacity

Document Type: Installation Manual
Part Number: IM2505AG
Release Date: 11/17