



## INSTALLATION MANUAL

HEATING | COOLING | HOT WATER

[www.geostar-geo.com](http://www.geostar-geo.com)



AFFORDABLE RENEWABLE CLEAN



ASTON AND ASTON ADVANCED  
SERIES INDOOR SPLIT

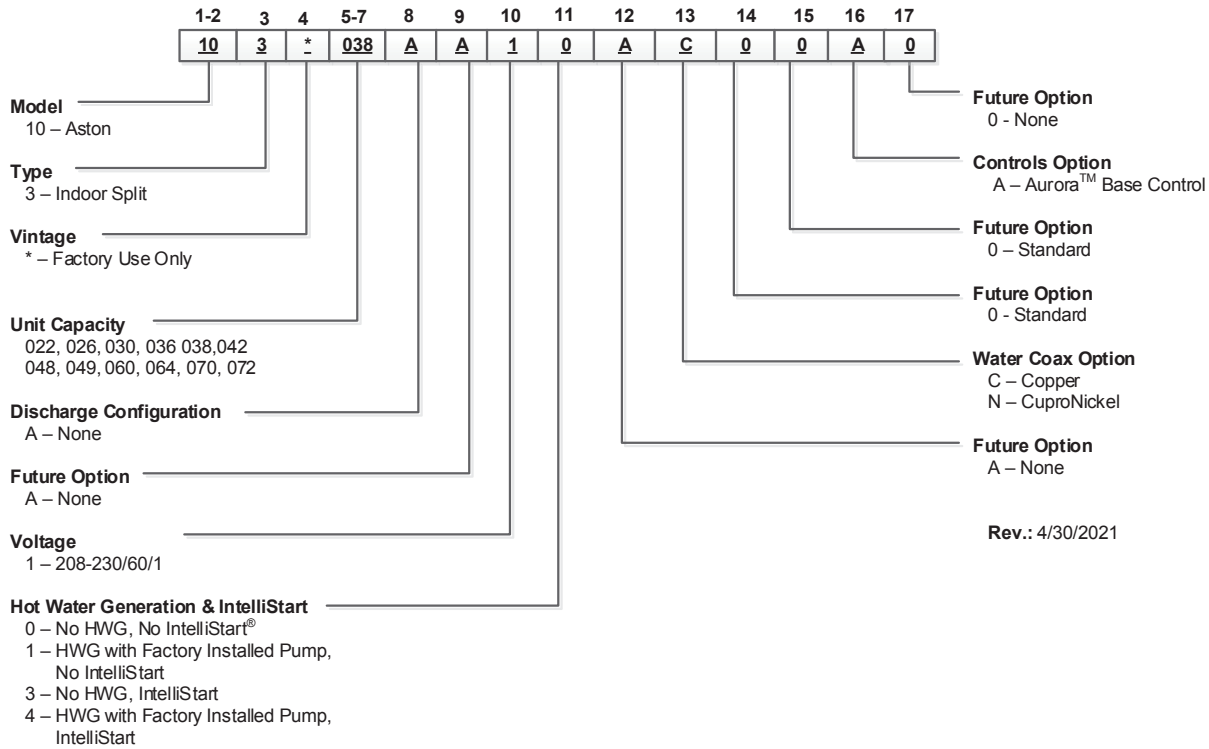


## Table of Contents

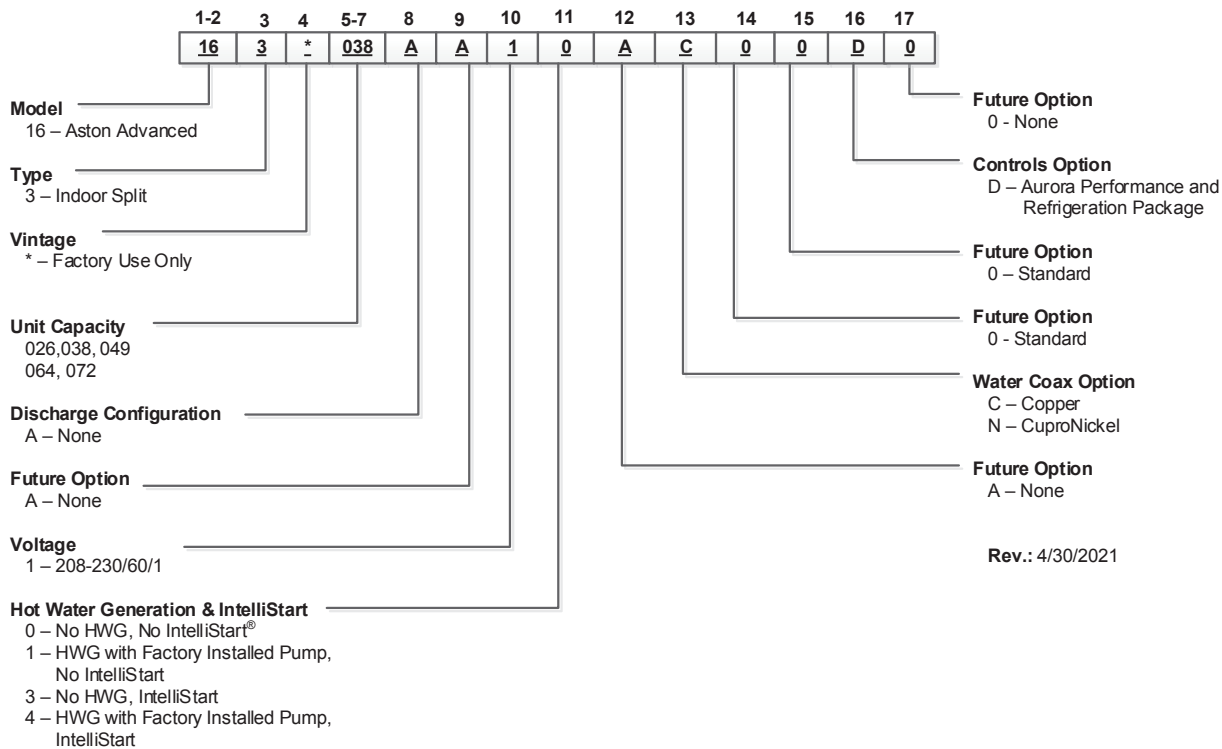
---

Model Nomenclature . . . . .	4
General Installation Information . . . . .	5-9
Water Quality . . . . .	9
Closed Loop - Ground Source Systems . . . . .	10-11
Open Loop - Well Water Systems . . . . .	12
Hot Water Generator Connections . . . . .	13-14
Electrical Connection . . . . .	15-16
Electronic Thermostat Installation . . . . .	16-17
Electrical Data . . . . .	18
Dimensional Data . . . . .	19
Physical Data . . . . .	20
Model Nomenclature - Air Handler . . . . .	21
Compatibility Guide - Air Handler . . . . .	22
Physical Data - Air Handler . . . . .	22
Model Nomenclature - Coil . . . . .	23
Refrigerant Coil Compatibility . . . . .	23
SR Coil Physical Characteristics . . . . .	23
The Aurora™ Control System . . . . .	24-32
Reference Calculations/Legend . . . . .	33
Wiring Schematics . . . . .	34-37
Refrigeration . . . . .	38-40
Line Set Sizes . . . . .	40
Pressure/Temperature Conversion Chart for R-410A . . . . .	41
Unit Startup . . . . .	42-44
Operating Parameters . . . . .	45-46
Antifreeze Corrections . . . . .	47
Correction Factor Tables . . . . .	48
Pressure Drop . . . . .	49
Refrigerant Circuit Guideline . . . . .	50
Thermistor/Compressor Resistance . . . . .	51
Heat of Extraction/Rejection Data . . . . .	52-53
Troubleshooting . . . . .	54-57
Preventative Maintenance . . . . .	58
Replacement Procedures . . . . .	58
Service Parts List . . . . .	59
Revision Guide . . . . .	61

## Model Nomenclature - Aston



## Model Nomenclature - Aston Advanced



## General Installation Information

### Safety Considerations



**WARNING: Before performing service or maintenance operations on a system, turn off main power switches to the indoor unit. If applicable, turn off the accessory heater power switch. Electrical shock could cause personal injury.**

Installing and servicing heating and air conditioning equipment can be hazardous due to system pressure and electrical components. Only trained and qualified service personnel should install, repair or service heating and air conditioning equipment. Untrained personnel can perform the basic maintenance functions of cleaning coils and cleaning and replacing filters. All other operations should be performed by trained service personnel. When working on heating and air conditioning equipment, observe precautions in the literature, tags and labels attached to the unit and other safety precautions that may apply, such as the following safety measures:

- Follow all safety codes.
- Wear safety glasses and work gloves.
- Use a quenching cloth for brazing operations.
- Have a fire extinguisher available for all brazing operations.

### Moving and Storage

Move units in the normal “up” orientation. Units may be moved and stored per the information on the packaging. Do not stack more than three units in total height. Do not attempt to move units while stacked. When the equipment is received, all items should be carefully checked against the bill of lading to be sure all crates and cartons have been received. Examine units for shipping damage, removing the units from the packaging if necessary. Units in question should also be internally inspected. If any damage is noted, the carrier should make the proper notation on the delivery receipt, acknowledging the damage.

### Unit Location

**NOTE:** Prior to setting the unit in place, remove and discard the compressor shipping bolt located at the front of the compressor mounting bracket.

Locate the unit in an indoor area that allows for easy removal of the access panels. Location should have enough space for service personnel to perform maintenance or repair. Provide sufficient room to make water, electrical and refrigerant line connections. Any access panel screws that would be difficult to remove after the unit is installed should be removed prior to setting the unit. Care should be taken when units are located in unconditioned spaces to prevent damage from frozen water lines and excessive heat that could damage electrical components.

### Air Coil Location

Refer to the air handler manufacturer’s instructions for the blower coil unit for details on installing the air handling portion of the system.

### Condensate Drain

Follow the blower coil manufacturer’s instructions.

### Duct System

All blower coil units/air coils must be installed as specified by the manufacturer’s installation instructions; however, the following recommendations should be considered to minimize noise and service problems.

An air filter must always be installed upstream of the air coil on the return air side of the air handler or furnace. If there is limited access to the filter rack for normal maintenance, it is suggested that a return air filter grill be installed. Be sure that the return duct is properly installed and free of leaks to prevent dirt and debris from bypassing the filter and plugging the air coil.

In applications using galvanized metal ductwork, a flexible duct connector is recommended on both the supply and return air plenums to minimize vibration from the blower. To maximize sound attenuation of the unit blower, the supply and return plenums should include an internal duct liner of 1-inch thick glass fiber or be constructed of ductboard. Insulation is usually not installed in the supply branch ducts. Ducts in unconditioned areas should be wrapped with a minimum of 1-inch duct insulation. Application of the unit to uninsulated ductwork in an unconditioned space is not recommended as the unit’s performance will be adversely affected. If the air handler is connected to existing ductwork, a previous check should have been made to assure that the duct system has the capacity to handle the air required for the unit application. If ducting is too small, as in replacement of heating only systems, larger ductwork should be installed. All existing ductwork should be checked for leaks and repairs made accordingly. The duct systems and diffusers should be sized to handle the design airflow quietly. If air noise or excessive airflow is a problem, the blower speed can be changed to a lower speed to reduce airflow. This will reduce the performance of the unit slightly in heating; however, it will increase the temperature rise across the air coil. Airflow must still meet minimum requirements.

### Equipment Selection

The following guidelines should be used when mating a Indoor Split to an air handler/coil.

- Select R-410A components only.
- Select 13 SEER or higher air handler/coil.
- Match the air handler to the air handler coil data table.
- Indoor matching adjustable TXV should be used with any air handler/coil. Fixed orifice or cap tube systems should not be used.

### Utilizing Existing Coil or Air Handler

It is recommended that a new R-410A air handler be installed with a Indoor Split considering the long term benefits of reliability, warranty, etc. versus the short term installation cost savings. However, the existing air handler may be retained provided the following:

- Coil currently is R-410A rated
- Coil uses a TXV. No capillary or fixed orifice systems should be used
- A life expectancy of more than 7 years remaining for the air handler and components
- Flush air coil and line set

## General Installation Information cont.

When utilizing the existing air coil or line set, only flushing compounds that vaporize should be used; which means they are packaged in a pressurized disposable cylinder. It is preferable to use a flushing agent that removes oil, water, and acid, plus, is biodegradable and non-toxic. The flushing agent should be safe to use with both HCFC and HFC refrigerants. Once a flushing agent has been selected, follow the instructions provided with the product.

The first step should be purging the lines or air coil with nitrogen. Purging with nitrogen first will remove some of the particulate and residual oil which will allow the flushing agent to work better. Never blow the flushing agent through a compressor, filter drier, or txv as it will cause the components to fail.

When flushing is complete and the final system is assembled, an acid check should be preformed on the system. Acid test kits are available from most HVACR distributors.

### Connection to Air Coil

Figures 1 and 2 illustrate typical Indoor Split installations. Reference the Line Set Sizes table for typical line set diameters and maximum length. Line sets over 60 feet are not recommended. Longer line sets will significantly reduce capacity and efficiency of the system as well as adversely effect the system reliability due to poor oil return. If the line set is kinked or deformed and cannot be reformed, the bad section of pipe should be replaced. A restricted line set will affect unit performance. As in all R-410A equipment, a reversible liquid line filter drier is required to insure all moisture is removed from the system. This drier should be replaced whenever “breaking into” the system for service. All line sets should be insulated with a minimum of 1/2 in. closed cell insulation. All exterior insulation should be painted with UV resistant paint or covering to ensure long insulation life.

### Air Handler Installation

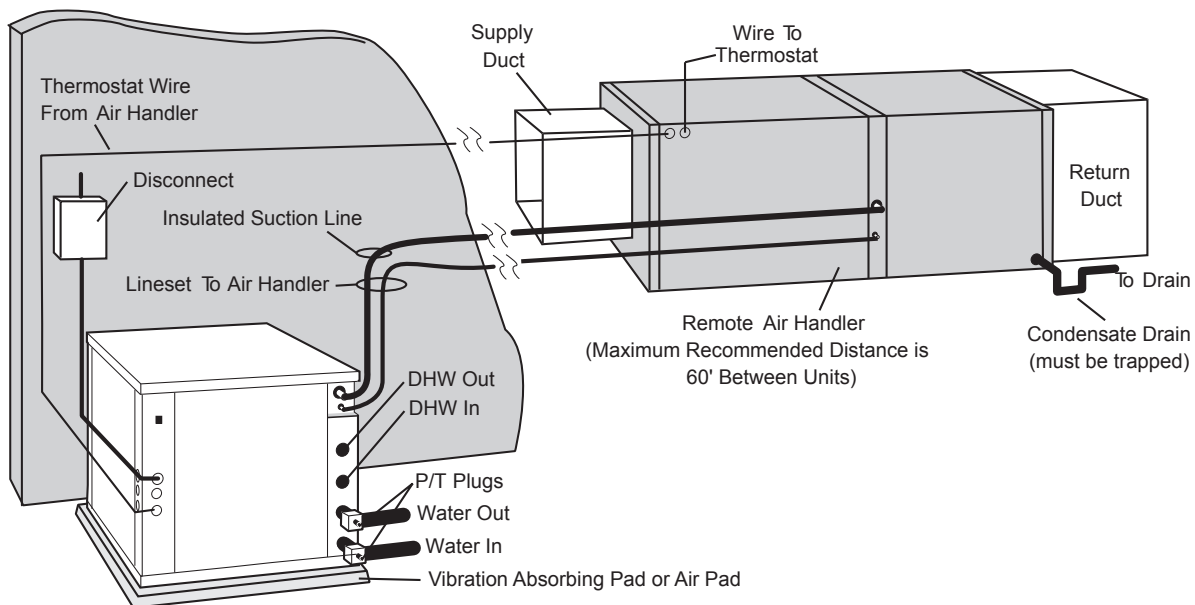
Air handlers used with dual capacity units must be capable of operating with a minimum of 2 blower speeds. Refer to the manufacturer’s instructions for the blower coil unit for details on installing the air handling portion of the system. All blower coil units/air coils must be installed as specified by the manufacturer’s installations instructions. However, the following recommendations should be considered to minimize noise and service problems.

An air filter must always be installed upstream of the air coil on the return air side of the air handler or furnace. If there is limited access to the filter rack for normal maintenance, it is suggested that a return air filter grille be installed. Be sure that the return duct is properly installed and free of leaks to prevent dirt and debris from bypassing the filter and plugging the air coil.

Ensure that the line set size is appropriate to the capacity of the unit (refer to Line Set Sizes table). Line sets should be routed as directly as possible, avoiding unnecessary bends or turns. All wall penetrations should be sealed properly. Line set should not come into direct contact with water pipes, floor joists, wall studs, duct work, floors, walls and brick. Line set should not be suspended from joists or studs with a rigid wire or strap which comes into direct contact with the tubing. Wide hanger strips which conform to the shape of the tubing are recommended. Isolate hanger straps from line set insulation by using metal sleeves bent to conform to the shape of insulation. Line set insulation should be pliable, and should completely surround the refrigerant line.

**NOTES:** Improper installation of equipment may result in undesirable noise levels in the living areas.

**Figure 1: Typical Split System Application with Remote Blower Coil**



## General Installation Information cont.

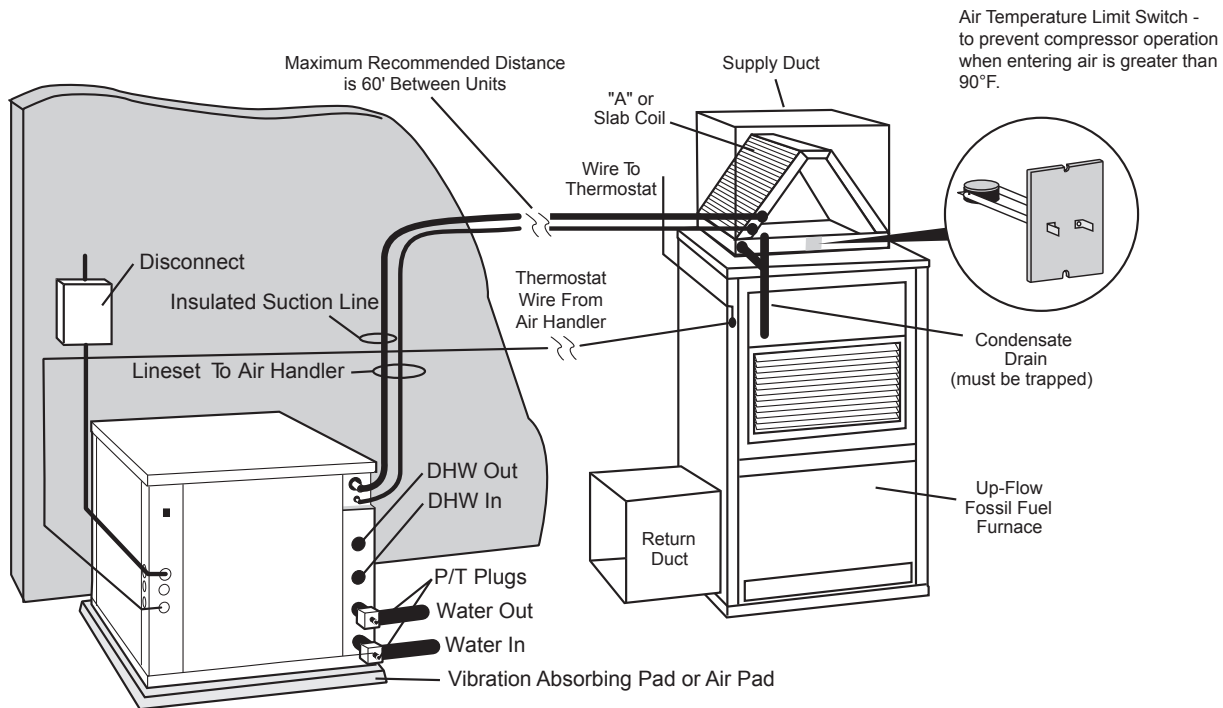
### Dual Fuel Systems

Indoor split units can be connected to fossil fuel furnaces that include an A-coil or slab coil. Dual fuel installations utilize the geothermal heat pump for heating until the point that auxiliary heat is called for on the thermostat. At that point, the furnace will be enabled and the heat pump will be disabled. The geothermal heat pump provides air conditioning through the furnace's refrigerant coils.

Refer to the furnace manufacturer's installation manual for the furnace installation, wiring and coil insertion. A WaterFurnace Dual Fuel thermostat, a field-installed SPST relay or dual capacity auxiliary heat relay is required. See Figure 2 for typical Dual Fuel application.

In add-on Indoor Split applications, the coil should be located in the supply side of the furnace to avoid condensation damage to the furnace heat exchanger. A high temperature limit switch should be installed upstream of the coil to de-energize the compressor whenever the furnace is operating. Without this switch, the Indoor Split will trip out on high pressure. A dual fuel thermostat can remove the Y1 and Y2 calls when a W call is energized to allow gas furnace backup on a Indoor Split application. Refer to thermostat wiring diagram for details.

**Figure 2: Typical Split System Heat Pump Coil Add-On Fossil Fuel Furnace**



## General Installation Information cont.

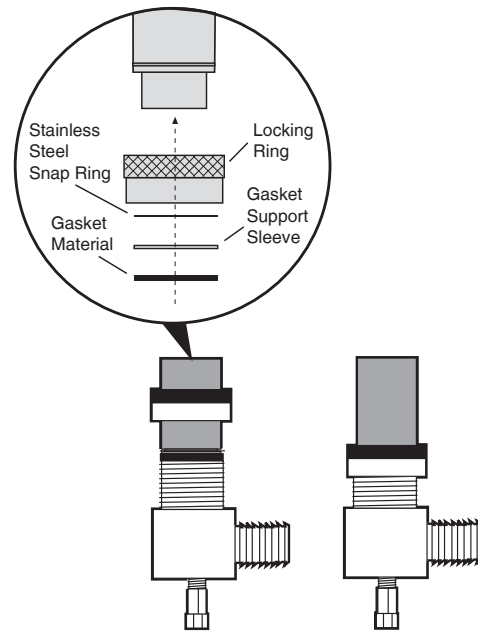
### Water Piping

The proper water flow must be provided to each unit whenever the unit operates. To assure proper flow, use pressure/temperature ports to determine the flow rate. These ports should be located at the supply and return water connections on the unit. The proper flow rate cannot be accurately set without measuring the water pressure drop through the refrigerant-to-water heat exchanger.

All source water connections on residential units are swivel piping fittings (see Figure 3) that accept 1 in. male pipe threads (MPT). The swivel connector has a rubber gasket seal similar to a rubber hose gasket, which when mated to the flush end of any 1 in. threaded pipe provides a leak-free seal without the need for thread sealing tape or compound. Check to ensure that the rubber seal is in the swivel connector prior to attempting any connection. The rubber seals are shipped attached to the waterline. To make the connection to a ground loop system, mate the brass connector (supplied in CK4L connector kit) against the rubber gasket in the swivel connector and thread the female locking ring onto the pipe threads, while maintaining the brass connector in the desired direction. Tighten the connectors by hand, then gently snug the fitting with pliers to provide a leak-proof joint. When connecting to an open loop (ground water) system, thread the 1 in. MPT fitting (SCH80 PVC or copper) into the swivel connector and tighten in the same manner as noted above. The open and closed loop piping system should include pressure/temperature taps for serviceability.

Never use flexible hoses smaller than 1 in. inside diameter on the unit. Limit hose length to 10 ft. per connection. Check carefully for water leaks.

**Figure 3: Swivel Connections (Residential Units)**





## General Installation Information cont.

### Water Quality

It is the responsibility of the system designer and installing contractor to ensure that acceptable water quality is present and that all applicable codes have been met in these installations. Failure to adhere to the guidelines in the water quality table could result in loss of warranty. In ground water situations where scaling could be heavy or where biological growth such as iron bacteria will be present, a closed loop system is recommended. The heat exchanger coils in ground water systems may, over a period of time, lose heat exchange capabilities due to a buildup of mineral deposits inside. These can be cleaned, but only by a qualified service mechanic, as special solutions and pumping equipment are required. Hot water generator coils can likewise become scaled and possibly plugged. In areas with extremely hard water, the owner should be informed that the heat exchanger may require occasional flushing.

Units with cupronickel heat exchangers are recommended for open loop applications due to the increased resistance to build-up and corrosion, along with reduced wear caused by acid cleaning. Failure to adhere to the guidelines in the water quality table could result in the loss of warranty.

### Water Treatment

Do not use untreated or improperly treated water. Equipment damage may occur. The use of improperly treated or untreated water in this equipment may result in scaling, erosion, corrosion, algae or slime. Purchase of a pre-mix antifreeze could significantly improve system reliability if the water quality is controlled and there are additives in the mixture to inhibit corrosion. There are many examples of such fluids on the market today such as Environol™ 1000 (pre-mix ethanol), and others. The services of a qualified

water treatment specialist should be engaged to determine what treatment, if any, is required. The product warranty specifically excludes liability for corrosion, erosion or deterioration of equipment.

The heat exchangers and water lines in the units are copper or cupronickel tube. There may be other materials in the buildings piping system that the designer may need to take into consideration when deciding the parameters of the water quality. If antifreeze or water treatment solution is to be used, the designer should confirm it does not have a detrimental effect on the materials in the system.

### Contaminated Water

In applications where the water quality cannot be held to prescribed limits, the use of a secondary or intermediate heat exchanger is recommended to separate the unit from the contaminated water. The table above outlines the water quality guidelines for unit heat exchangers. If these conditions are exceeded, a secondary heat exchanger is required. Failure to supply a secondary heat exchanger where needed will result in a warranty exclusion for primary heat exchanger corrosion or failure.

### Low Water Coil Limit

Set the freeze sensing switch SW2-1 on the Aurora Base Control (ABC) printed circuit board for applications using a closed loop antifreeze solution to "LOOP" (15°F). On applications using an open loop/ground water system (or closed loop no antifreeze), set this dip switch to "WELL" (30°F), the factory default setting. (Refer to the DIP Switch Settings table in the Aurora Control section.)

Material		Copper	90/10 Cupronickel	316 Stainless Steel
pH	Acidity/Alkalinity	7 - 9	7 - 9	7 - 9
Scaling	Calcium and Magnesium Carbonate	(Total Hardness) less than 350 ppm	(Total Hardness) less than 350 ppm	(Total Hardness) less than 350 ppm
Corrosion	Hydrogen Sulfide	Less than 0.5 ppm (rotten egg smell appears at 0.5 ppm)	10 - 50 ppm	Less than 1 ppm
	Sulfates	Less than 125 ppm	Less than 125 ppm	Less than 200 ppm
	Chlorine	Less than 0.5 ppm	Less than 0.5 ppm	Less than 0.5 ppm
	Chlorides	Less than 20 ppm	Less than 125 ppm	Less than 300 ppm
	Carbon Dioxide	Less than 50 ppm	10 - 50 ppm	10 - 50 ppm
	Ammonia	Less than 2 ppm	Less than 2 ppm	Less than 20 ppm
	Ammonia Chloride	Less than 0.5 ppm	Less than 0.5 ppm	Less than 0.5 ppm
	Ammonia Nitrate	Less than 0.5 ppm	Less than 0.5 ppm	Less than 0.5 ppm
	Ammonia Hydroxide	Less than 0.5 ppm	Less than 0.5 ppm	Less than 0.5 ppm
	Ammonia Sulfate	Less than 0.5 ppm	Less than 0.5 ppm	Less than 0.5 ppm
Total Dissolved Solids (TDS)	Less than 1000 ppm	1000 - 1500 ppm	1000 - 1500 ppm	
LSI Index	+0.5 to -0.5	+0.5 to -0.5	+0.5 to -0.5	
Iron Fouling (Biological Growth)	Iron, FE <sup>2+</sup> (Ferrous) Bacterial Iron Potential	< 0.2 ppm	< 0.2 ppm	< 0.2 ppm
	Iron Oxide	Less than 1 ppm, above this level deposition will occur	Less than 1 ppm, above this level deposition will occur	Less than 1 ppm, above this level deposition will occur
Erosion	Suspended Solids	Less than 10 ppm and filtered for max. of 600 micron size	Less than 10 ppm and filtered for max. of 600 micron size	Less than 10 ppm and filtered for max. of 600 micron size
	Threshold Velocity (Fresh Water)	< 6 ft/sec	< 6 ft/sec	< 6 ft/sec

NOTES: Grains = ppm divided by 17  
mg/L is equivalent to ppm

2/22/12

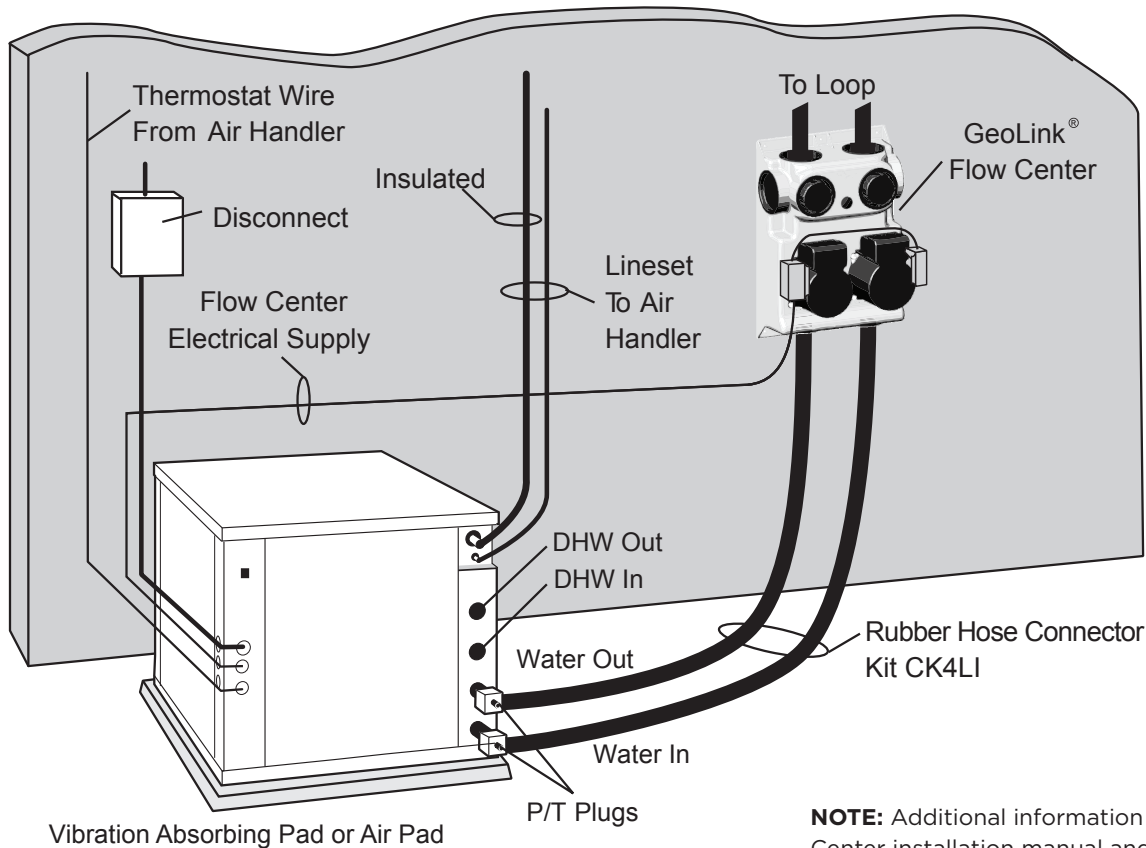
## Closed Loop - Ground Source Systems

**NOTE:** For closed loop systems with antifreeze protection, set SW2-1 to the “LOOP” (15°F) position. (Refer to the DIP Switch Settings table in the Aurora Control section.)

Once piping is completed between the unit, pumps and the ground loop (see figure below), final purging and charging of the loop is required. A flush cart (or a 1.5 HP pump minimum) is needed to achieve adequate flow velocity in the loop to purge air and dirt particles from the loop itself. Antifreeze solution is used in most areas to prevent freezing. Flush the system adequately to remove as much air as possible then pressurize the loop to a static pressure of 40-50 psi (summer) or 50-75 psi (winter). This is normally adequate for good system operation. Loop static pressure will fluctuate with the seasons. Pressures will be higher in the winter months than during the cooling season. This fluctuation is normal and should be considered when initially charging the system.

After pressurization, be sure to turn the venting (burping) screw in the center of the pump two (2) turns open (water will drip out), wait until all air is purged from the pump, then tighten the plug. Ensure that the loop pumps provide adequate flow through the unit(s) by checking the pressure drop across the heat exchanger and comparing it to the unit capacity data in this catalog. 2.5 to 3 gpm of flow per ton of cooling capacity is recommended in earth loop applications.

**Figure 4: Typical Split System Application Closed Loop - Earth Coupled**



**NOTE:** Additional information can be found in Flow Center installation manual and Flush Cart manual.

## Closed Loop - Ground Source Systems cont.

### Multiple Units on One Flow Center

**NOTE:** This feature is only available in the Aurora Advanced Control package (AXB board), NOT the Aurora Base Control (ABC).

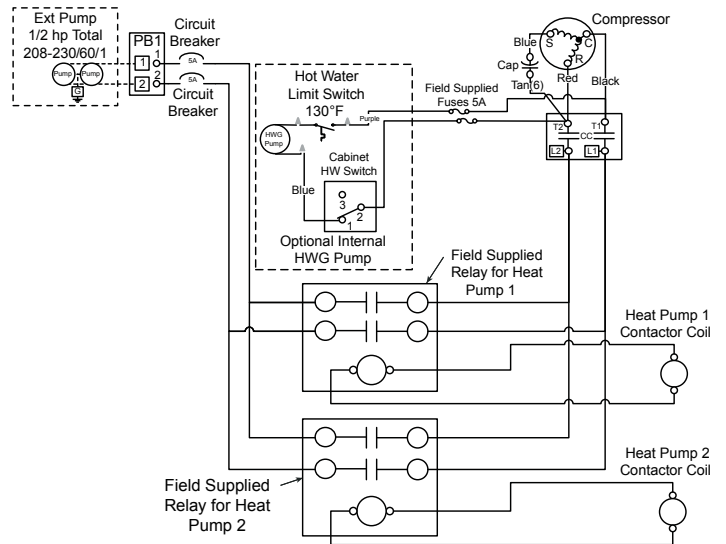
When two units are connected to one loop pumping system, pump control is automatically achieved by connecting the SL terminals on connector P2 in both units with 2-wire thermostat wire. These terminals are polarity dependant (see Figure 5b). The loop pump(s) may be powered from either unit, whichever is more convenient. If either unit calls, the loop pump(s) will automatically start. The use of two units on one flow center is generally limited to a total of 20 gpm capacity. It is recommended that water solenoid valves be installed on heat pumps that share a flow center. This is to allow water flow through only the heat pump that has a demand. Circulating fluid through a heat exchanger of a system that is not operating could be detrimental to the long term reliability of the compressor.

**NOTE:** To achieve this same feature when heat pumps have only the Aurora Base Control, follow Figure 5a. Installer will be required to supply fuses, two relays, and wiring.

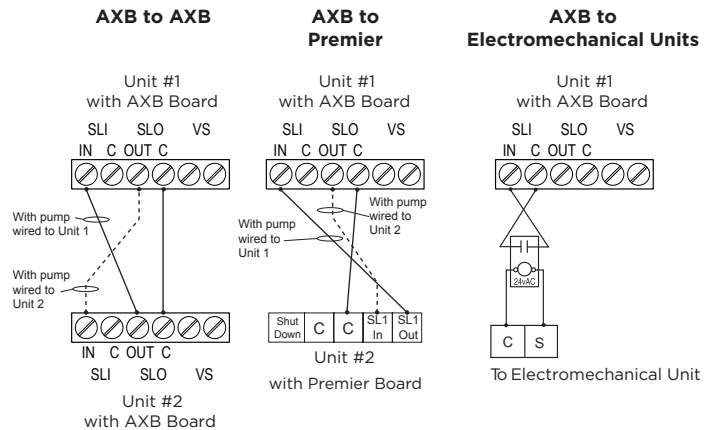
### Variable Speed Pump Setup

When using a variable speed pump flow center (FCV1-GL or FCV2-GL) the use of an AID Tool will be necessary to adjust minimum and maximum flow rates. The factory default is: minimum=75% and maximum=100% speed levels.

**Figure 5a: Primary/Secondary Wiring with Aurora Base Control (no AXB Board)**



**Figure 5b: Primary/Secondary Hook-up**



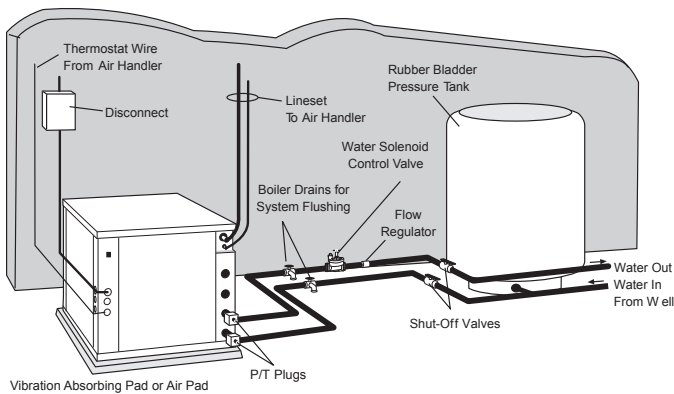
## Open Loop - Well Water Systems

Typical open loop piping is shown below. Always maintain water pressure in the heat exchanger by placing water control valves at the outlet of the unit to prevent mineral precipitation. Use a closed, bladder-type expansion tank to minimize mineral formation due to air exposure. Ensure proper water flow through the unit by checking pressure drop across the heat exchanger and comparing it to the figures in unit capacity data tables in the specification catalog. 1.5-2 gpm of flow per ton of cooling capacity is recommended in open loop applications.

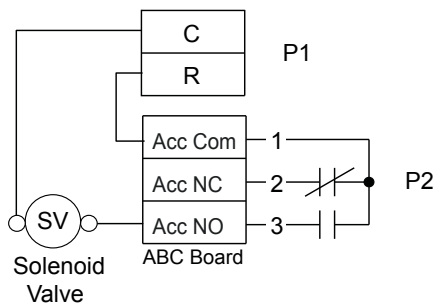
Discharge water from the unit is not contaminated in any manner and can be disposed of in various ways, depending on local codes, i.e. recharge well, storm sewer, drain field, adjacent stream or pond, etc. Most local codes forbid the use of sanitary sewer for disposal. Consult your local building and zoning departments to assure compliance in your area.

**NOTE:** For open loop/groundwater systems or systems that do not contain an antifreeze solution, set SW2-Switch #1 to the "WELL" (30°F) position. (Refer to the DIP Switch Settings table in the Aurora Control section.) Slow opening/closing solenoid valves (type V or VM) are recommended to eliminate water hammer.

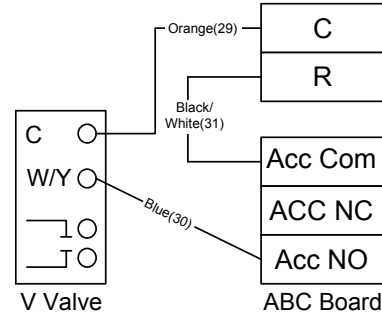
**Figure 6: Typical Split System Application Open Loop - Well Water**



**Figure 7a: Open Loop Solenoid Valve Connection Option**  
 Typical quick operating external 24V water solenoid valve (type PPV100 or BPV100) wiring.

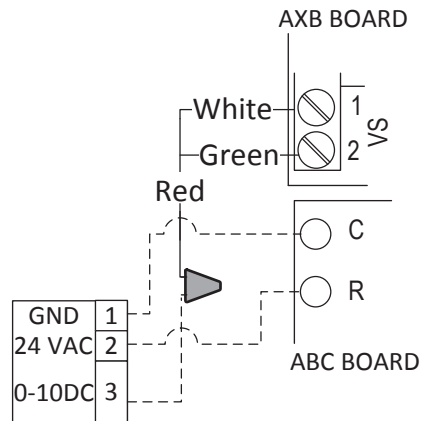


**Figure 7b: Open Loop Solenoid Valve Connection Option**  
 Typical slow operating external 24V water solenoid valve (type V100FPT) wiring.



**NOTE:** SW2-4 should be "ON" and SW2-5 should be "OFF" when using a slow opening (V100FPT) water valve.

**Figure 7c: Modulating Water Valve Connection Option**  
 Typical 0-10VDC modulating water valve.



**NOTE:** Wiring harness is supplied with valve.

## Hot Water Generator Connections

The heat reclaiming hot water generator coil is vented double-wall copper construction and is suitable for potable water. To maximize the benefits of the hot water generator a minimum 50-gallon water heater is recommended. For higher demand applications, use an 80-gallon water heater or two 50-gallon water heaters connected in a series as shown below. A geo storage tank should not be used in this application unless it is plumbed in a series with an electric water heater. The geo storage tank is equipped with a single 4500 Watt element and will not be able to provide adequate water heating if used as a standalone water heater. Electric water heaters are recommended. Make sure all local electrical and plumbing codes are followed when installing a hot water generator. Residential units with hot water generators contain an internal circulator and fittings. A water softener is recommended for hard water applications (greater than 10 grains or 170 ppm total hardness).

### Water Tank Preparation

To install a unit with hot water generator, follow these installation guidelines.

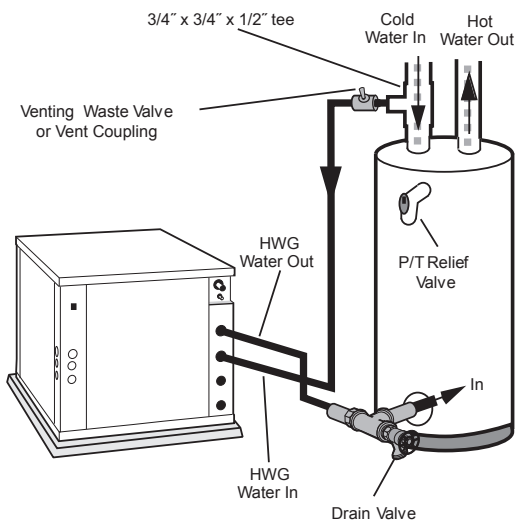
1. Turn off the power to the water heater.
2. Attach a water hose to the water tank drain connection and run the other end of the hose to an open drain or outdoors.
3. Close the cold water inlet valve to the water heater tank.
4. Drain the tank by opening the valve on the bottom of the tank, then open the pressure relief valve or hot water faucet.

5. Flush the tank by opening the cold water inlet valve to the water heater to free the tank of sediments. Close when draining water is clear.
6. Disconnect the garden hose and remove the drain valve from the water heater.
7. Refer to Plumbing Installation and Hot Water Generator Startup.

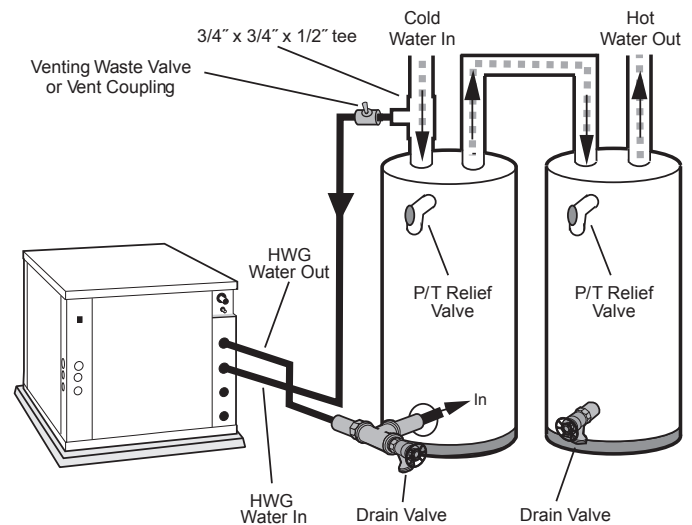


**CAUTION: Elements will burn out if energized dry.**

**Figure 8: Typical Hot Water Generator Installation**



**Figure 9: Hot Water Generator Installation in Preheat Tank**



## Hot Water Generator Connections cont.

### Plumbing Installation

1. Inspect the dip tube in the water heater cold inlet for a check valve. If a check valve is present it must be removed or damage to the hot water generator circulator will occur.
2. Remove drain valve and fitting.
3. Thread the 3/4-inch NPT x 3-1/2-inch brass nipple into the water heater drain port.
4. Attach the center port of the 3/4-inch FPT tee to the opposite end of the brass nipple.
5. Attach the 1/2-inch copper to 3/4-inch NPT adaptor to the side of the tee closest to the unit.
6. Install the drain valve on the tee opposite the adaptor.
7. Run interconnecting tubing from the tee to hot water generator water out.
8. Cut the cold water "IN" line going to the water heater.
9. Insert the reducing solder tee in line with cold water "IN" line as shown.
10. Run interconnecting copper tubing between the unit hot water generator water "IN" and the tee (1/2-inch nominal). The recommended maximum distance is 50 feet.
11. To prevent air entrapment in the system, install a vent coupling at the highest point of the interconnecting lines.
12. Insulate all exposed surfaces of both connecting water lines with 3/8-inch wall closed cell insulation.

**NOTE:** All plumbing and piping connections must comply with local plumbing codes.

### Hot Water Generator Switch

The hot water generator switch is taped in the disabled position at the factory.



### Hot Water Generator Startup

1. Turn the hot water generator switch to the "ON" position. The hot water generator switch will allow the hot water generator pump to be enabled or disabled by the service technician or homeowner.
2. Close the drain valve to the water heater.
3. Open the cold water supply to the tank.
4. Open a hot water faucet in the building to bleed air from the system. Close when full.
5. Open the pressure relief valve to bleed any remaining air from the tank, then close.
6. If so equipped, turn the venting (burping) screw in the center of the pump two (2) turns open (water will drip out), wait until all air is purged from the pump, then tighten the plug. Use vent couplings to bleed air from the lines.
7. Carefully inspect all plumbing for water leaks and correct as required.
8. Before restoring electrical supply to the water heater, adjust the temperature setting on the tank.
  - On tanks with both upper and lower elements, the lower element should be turned down to the lowest setting, approximately 100°F. The upper element should be adjusted to 120°F to 130°F. Depending upon the specific needs of the customer, you may want to adjust the upper element differently.
  - On tanks with a single element, lower the thermostat setting to 120°F.
9. After the thermostat(s) is adjusted, replace the access cover and restore electrical supply to the water heater.
10. Make sure that any valves in the hot water generator water circulating circuit are open.
11. Turn on the unit to first stage heating.
12. Use an AID Tool to enable HWG and select the desired water heating set point. Selectable set points are 100°F - 140°F in 5°F increments (default 130°F). From the Main Menu of the AID Tool select Setup, then AXB Setup.
13. The hot water generator pump should be running. When the pump is first started, turn the venting (burping) screw (if equipped) in the center of the pump two (2) turns open until water dribbles out, then replace. Allow the pump to run for at least five minutes to ensure that water has filled the circulator properly. Be sure the switch for the hot water generator pump switch is "ON".
14. The temperature difference between the water entering and leaving the hot water generator should be 5°F to 15°F. The water flow should be approximately 0.4 gpm per ton of nominal cooling.
15. Allow the unit to heat water for 15 to 20 minutes to be sure operation is normal.



**CAUTION:** Never operate the HWG circulating pump while dry. If the unit is placed in operation before the hot water generator piping is connected, be sure that the pump switch is set to the OFF position.

# Electrical Connections

## General

Be sure the available power is the same voltage and phase as that shown on the unit serial plate. Line and low voltage wiring must be done in accordance with local codes or the National Electric Code, whichever is applicable.

## Unit Power Connection

Connect the incoming line voltage wires to L1 and L2 of the contactor as shown in Figure 10C for single-phase unit. Consult the Unit Electrical Data in this manual for correct fuse sizes.

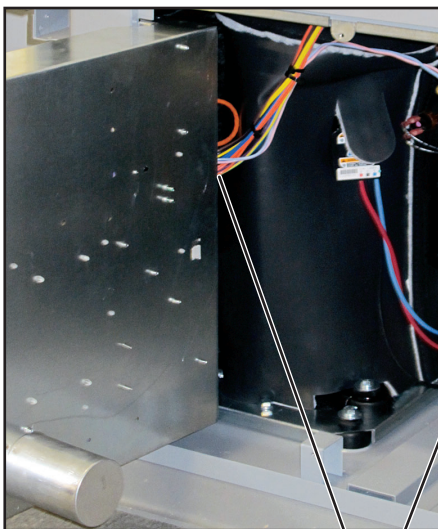
Open lower front access panel. Remove ground fastener from bottom of control box (Figure 10B). Swing open control box (Figure 10A). Insert power wires through knockouts on lower left side of cabinet. Route wires through left side of control box and connect to contactor and ground (Figure 10C). Close control box and replace grounding fastener before unit start-up.

## Accessory Relay

A set of “dry” contacts has been provided to control accessory devices, such as water solenoid valves on open loop installations, electronic air cleaners, humidifiers, etc. This relay contact should be used only with 24 volt signals and not line voltage power. The relay has both normally open and normally closed contacts and can operate with either the fan or the compressor. Use DIP switch SW2-4 and 5 to cycle the relay with blower, compressor, or control a slow opening water valve. The relay contacts are available on terminals #2 and #3 of P2.

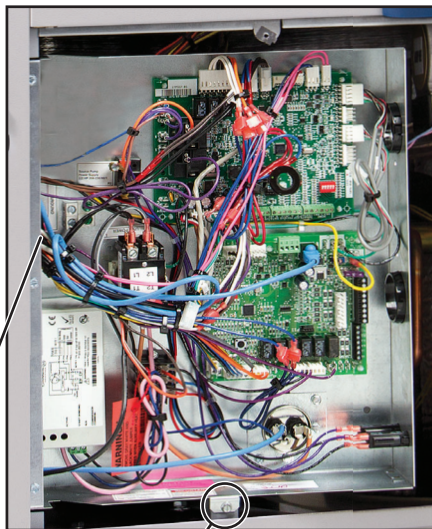
When powering high VA draw components such as electronic air cleaners or V type open loop water valves, R should be taken ‘pre-fuse’ from the ‘R’ quick connect on the ABC board and not the ‘post-fuse’ ‘R’ terminal on the thermostat connection. If not, blown ABC fuses might result.

**Figure 10A:**  
Wire access (control box open)



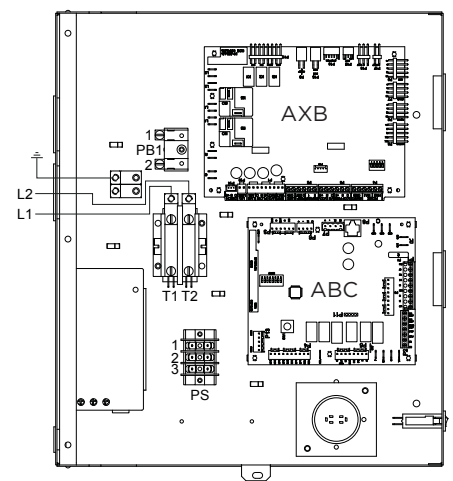
Wire Insert Location

**Figure 10B:**  
Wire access (control box closed)



Ground Fastener must be installed for proper unit ground

**Figure 10C:**  
Line Voltage 208-230/60/1 control box



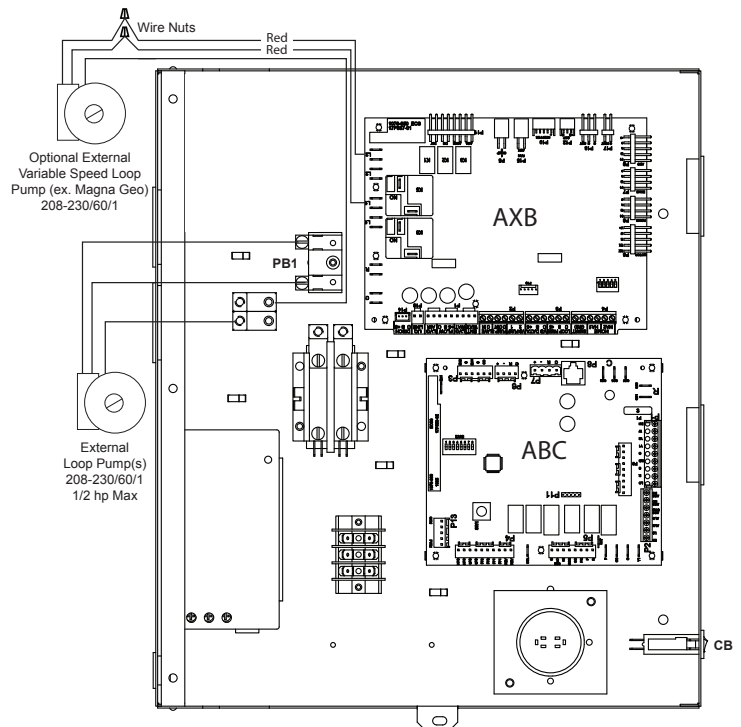
## Electrical Connections cont.

### Pump Power Wiring

See Figure 14 for electrical connections from control box to pumps.

FC1/FC2 style flow centers with fixed speed pumps connect to PB1 in the control box. If using a variable speed pump it should be connected to L1 and L2 on the AXB.

Figure 11: Pump Wiring 208-230/60/1



## Electronic Thermostat Installation

Position the thermostat subbase against the wall so that it is level and the thermostat wires protrude through the middle of the subbase. Mark the position of the subbase mounting holes and drill holes with a 3/16-inch bit. Install supplied anchors and secure base to the wall. Thermostat wire must be 8-conductor (4 or 5 conductor for communicating thermostats), 20-AWG (minimum) wire. Strip the wires back 1/4-inch (longer strip lengths may cause shorts) and insert the thermostat wires into the connector as shown. Tighten the screws to ensure secure connections. The thermostat has the same type connectors, requiring the same wiring. See instructions enclosed in the thermostat for detailed installation and operation information.

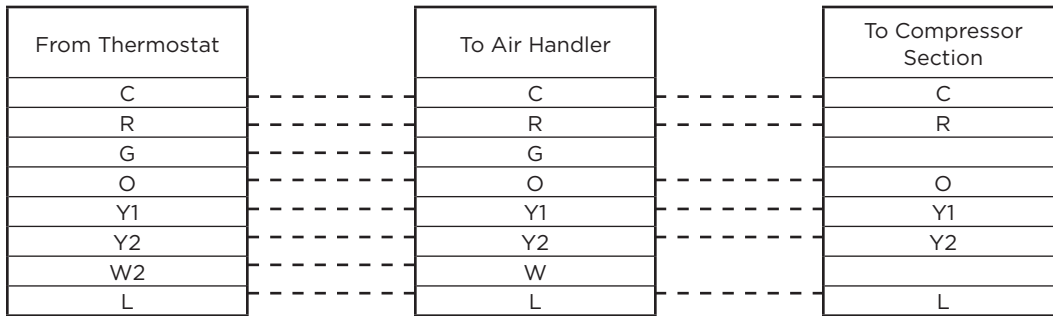
**NOTE:** Aurora Base Control (ABC) DIP switch SW2-7 is required to be in the “OFF” position for the control to operate with FaultFlash or ComforTalk thermostats. SW2-7 in the “ON” position configures the control to operate with typical thermostats (continuous lockout signal). There must be a wire connecting Y2 on the Aurora controller to 2nd stage compressor on the thermostat for proper operation. SW2-7 DIP switch position is not relevant with communicating thermostats.



## Electronic Thermostat Installation cont.

### Standard Non-Communicating Control Option A

Field low voltage point to point wiring:

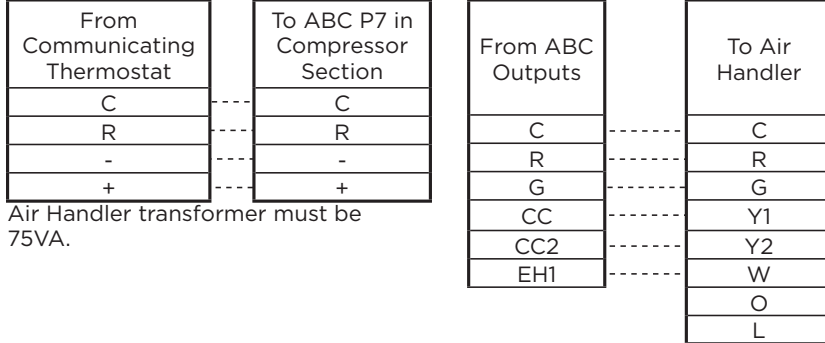


Air Handler transformer must be 75VA.

5/03/2017

### Communicating Thermostat Control Option A

Field low voltage point to point wiring:

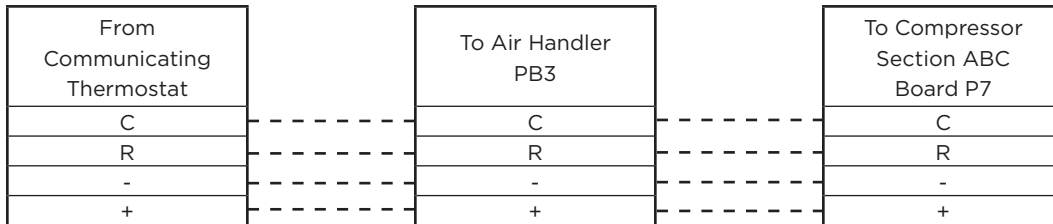


Air Handler transformer must be 75VA.

5/03/2017

### Communicating Thermostat Control Option C SAH Air Handler (AHB in Air Handler)

Field low voltage point to point wiring:

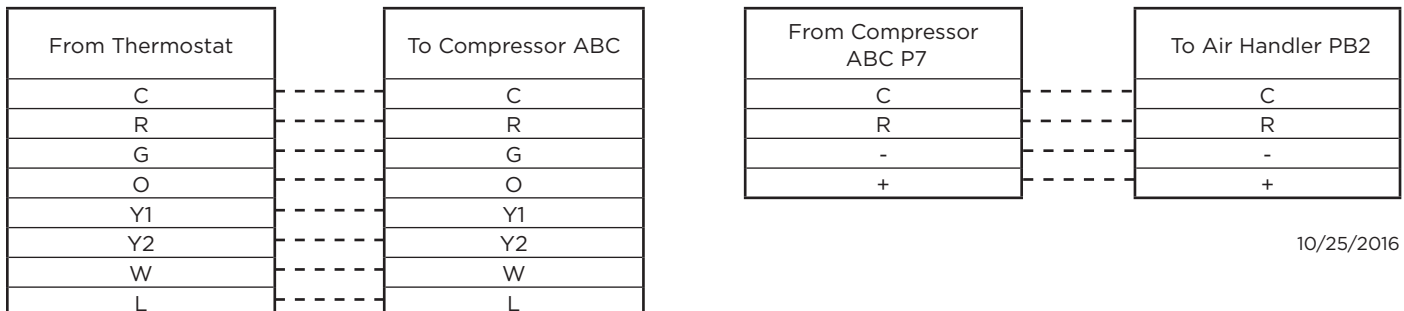


Air Handler transformer must be 100VA.

1/10/2017

### Non-Communicating Thermostat Control Option C - SAH Air Handler (AHB in Air Handler)

Field low voltage point to point wiring:



Air Handler transformer must be 100VA.

10/25/2016

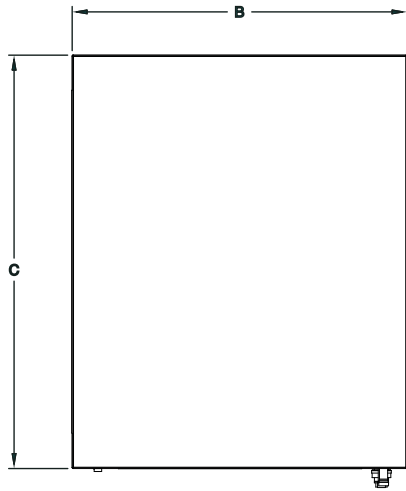
## Electrical Data

Model	Rated Voltage	Voltage Min/Max	Compressor				HWA Pump FLA	Ext Loop FLA	Total Unit FLA	Min Circ Amp	Max Fuse/HACR
			MCC	RLA	LRA	LRA*					
<b>022</b>	208-230/60/1	187/253	14.0	9.0	48.0	17.0	0.4	5.4	14.8	17.1	25
<b>030</b>	208-230/60/1	187/253	20.0	12.8	58.3	21.0	0.4	5.4	18.6	21.8	30
<b>036</b>	208-230/60/1	187/253	22.0	14.1	73.0	26.0	0.4	5.4	19.9	23.4	35
<b>042</b>	208-230/60/1	187/253	26.0	16.6	79.0	28.0	0.4	5.4	22.4	26.6	40
<b>048</b>	208-230/60/1	187/253	31.0	19.8	109.0	38.0	0.4	5.4	25.6	30.6	50
<b>060</b>	208-230/60/1	187/253	41.2	26.4	134.0	47.0	0.4	5.4	32.2	38.8	60
<b>070</b>	208-230/60/1	187/253	44.2	28.3	158.0	63.0	0.4	5.4	34.1	41.2	70
<b>026</b>	208-230/60/1	187/253	18.2	11.6	58.3	21.0	0.4	5.4	17.4	20.3	30
<b>038</b>	208-230/60/1	187/253	23.8	15.2	83.0	30.0	0.4	5.4	21.0	24.8	40
<b>049</b>	208-230/60/1	187/253	33.0	21.1	104.0	37.0	0.4	5.4	26.9	32.2	50
<b>064</b>	208-230/60/1	187/253	42.3	27.1	152.9	54.0	0.4	5.4	32.9	39.7	70
<b>072</b>	208-230/60/1	187/253	46.3	29.6	179.2	63.0	0.4	5.4	35.4	42.8	75

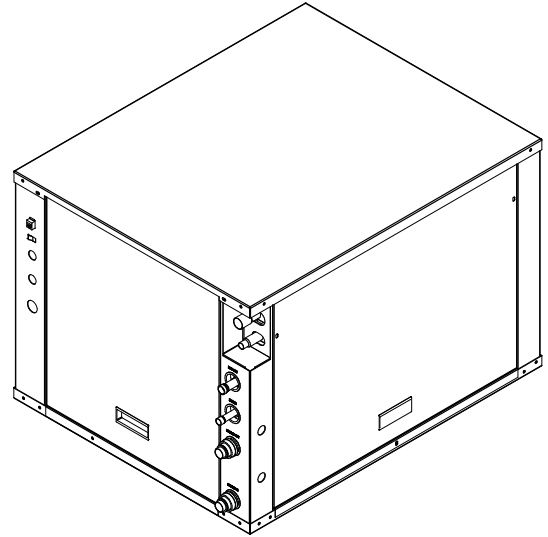
Rated voltage of 208-230/60/1  
 HACR circuit breaker in USA only  
 All fuses Class RK-5  
 \* With optional IntelliStart

4/3/13

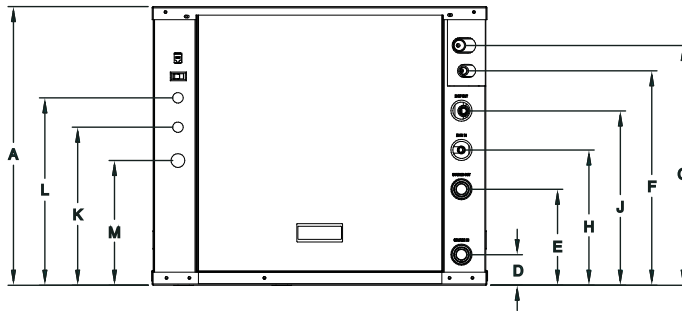
## Dimensional Data



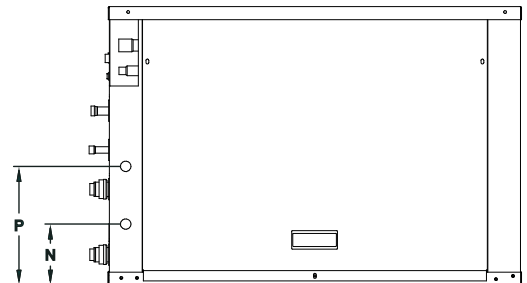
TOP



FRONT



SIDE



Model		Height	Width	Depth	Water In	Water Out	Service Valve		HWG In	HWG Out	Low Voltage	External Pump	Line Voltage	Knock Out	Knock Out
							Liquid	Gas							
		A	B	C	D	E	F	G	H	J	K	L	M	N	P
022-030	in.	19.3	22.5	26.5	1.93	6.93	15.2	16.8	9.4	11.9	12.1	14.3	9.5	4.6	8.2
	cm.	49.0	57.1	67.3	4.9	17.6	38.6	42.7	23.9	30.2	30.7	36.3	24.1	11.7	20.8
036-072	in.	21.25	25.62	31.6	2.3	7.21	16.4	18.3	10.3	13.3	12.1	14.3	9.5	4.7	9.1
	cm.	54.0	65.1	80.3	5.8	18.5	41.7	46.5	26.2	33.8	30.7	36.3	24.1	11.9	23.1

Dimensions are in inches.

Decorative molding and water connections extend 1.2 in. [30.5 mm] beyond the front of the cabinet.

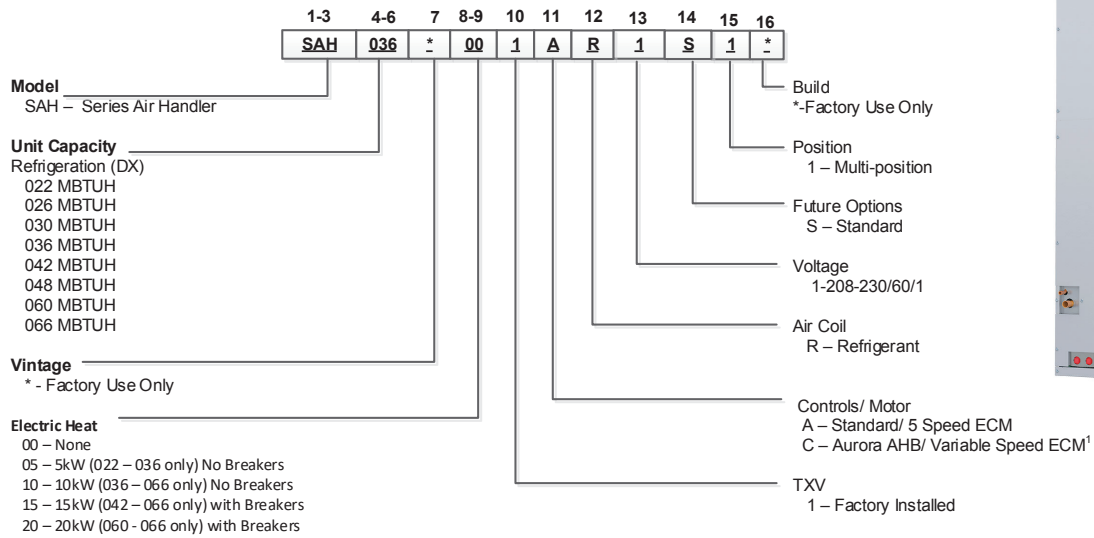
## Physical Data

Model	022	030	036	042	048	060	070	026	038	049	064	72
Compressor (1 each)	Single Speed Scroll							Dual Capacity Scroll				
Factory Charge R410a, oz [kg]	56 [1.59]	56 [1.59]	56 [1.59]	74 [2.1]	90 [2.55]	92 [2.61]	108 [3.06]	52 [1.47]	56 [1.59]	90 [2.55]	92 [2.61]	104 [2.95]
<b>Coax and Water Piping</b>												
Water Connections Size - Swivel- in [mm]	1 [25.4]							1 [25.4]				
HWG Connection Size - Female Sweat (I.D.) - in [mm]	1/2 [12.7]							1/2 [12.7]				
Brass Service Valve - Liquid Line - in [mm]	3/8 [9.525]					1/2 [12.7]		3/8 [9.525]			1/2 [12.7]	
Brass Service Valve - Suction Line - in [mm]	5/8 [15.875]			3/4 [19.05]		7/8 [22.225]		5/8 [15.875]	3/4 [19.05]		7/8 [22.225]	
Coax and Piping Water Volume - gal [l]	0.7 [2.6]	1.0 [3.8]	1.3 [4.9]	1.3 [4.9]	1.6 [6.1]	1.6 [6.1]	2.3 [8.7]	0.7 [2.6]	1.3 [4.9]	1.6 [6.1]	1.6 [6.1]	2.3 [8.7]
Weight - Operating, lb [kg]	164 [74]	174 [79]	212 [96]	213 [97]	246 [112]	251 [114]	292 [132]	189 [86]	236 [107]	250 [113]	271 [123]	290 [132]
Weight - Packaged, lb [kg]	184 [83]	194 [88]	232 [105]	233 [106]	266 [121]	271 [123]	312 [142]	209 [95]	256 [116]	270 [122]	291 [132]	310 [141]

**NOTES:** All units have TXV expansion devices, and 1/2 in. [12.2 mm] and 3/4 in. [19.1 mm] electrical knockouts.  
Brass service valves are sweat type valves.

6/27/11

# Model Nomenclature - Air Handler



**Note:** To field convert the SAH to bottomflow air discharge, the SAHBCK kit must be ordered.  
**Note:** Air flow on the 060 and 066 units in the horizontal configurations should be limited to 1900 cfm in cooling mode, or condensate blow off may occur.

Rev.: 2/27/2017

1. Only available with Aurora controls in the compressor section.

## Compatibility Table - Air Handler

### Air Handler Sizing Selection

The Air Handlers are designed for R-410A refrigerant and should be matched with split compressor section according to the table below.

Air Handler	Indoor Split Model (Single)	Indoor Split Model (Dual Capacity)	Outdoor Split Model (Dual Capacity)	Rated Airflow(CFM)	Electric Heat (kW)
SAH022***1*R1S1*	022	-		800	5
SAH026***1*R1S1*	-	026	026	850	5
SAH030***1*R1S1*	030	-	-	1000	5
SAH036***1*R1S1*	036	-	-	1200	5, 10
SAH036***1*R1S1*	-	038	038	1200	5, 10
SAH042***1*R1S1*	042	-	-	1300	10, 15
SAH048***1*R1S1*	048	-	-	1500	10, 15
SAH048***1*R1S1*	-	049	049	1500	10, 15
SAH060***1*R1S1*	060	-	-	1800	10, 15, 20
SAH060***1*R1S1*	-	064	064	1800	10, 15, 20
SAH066***1*R1S1*	070	-	-	2000	10, 15, 20
SAH066***1*R1S1*	-	072	072	2000	10, 15, 20

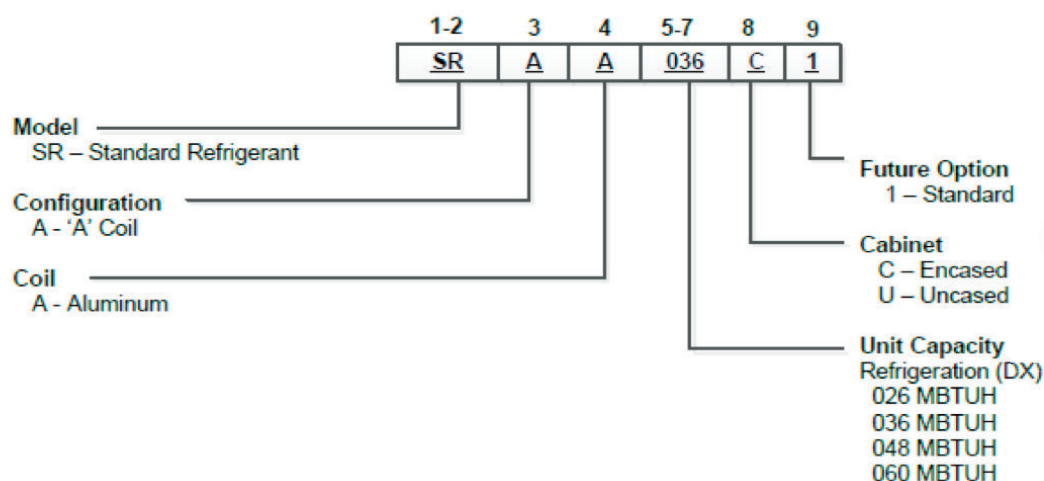
1/31/2017

## Physical Data - Air Handler

Air Handler Model Number (Refrigerant)		022	026	030	036	042	048	060	066
Evaporator Coil	Air Coil Total Face Area, ft2 [m2]	3.89 [0.36]			4.86 [0.45]	5.83 [0.54]		6.81 [0.63]	
	Tube outside diameter - in. [mm]	3/8 [9.52]							
	Number of rows	3							
	Fins per inch	12							
	Suction line connection - in. [mm] sweat	5/8 [15.87]			3/4 [19.05]			7/8 [22.23]	
Liquid line connection - in. [mm] sweat	3/8 [9.52]						1/2 [12.7]		
Refrigerant		R-410a							
Nominal cooling capacity - tons [kW]		1.8 [6.44]	2.1 [7.59]	2.5 [8.79]	3 [10.55]	3.5 [12.30]	4 [14.06]	5 [17.58]	5.5 [19.33]
Condensate drain connection - (FPT) in. [mm]		3/4 [19.05]							
Blower Wheel Size (Dia x W), in. [mm]		9 X 7 [229 x 178]			10 X 8 [254 x 203]		11 x 10 [279 x 254]		
Blower motor type/speeds		Variable Speed ECM/ 5 Speed ECM							
Blower motor output - hp [W]		1/2 [373]				1 [746]			
Filter Standard - 1" [51mm] Field Supplied.		16 X 20 [406 X 508]			20 X 20 [508 x 508]		22 X 20 [559 x 508]		
Electrical characteristics (60hz)		208/230 - 1ph							
Shipping weight - lbs. [kg]		147 [66.7]			168 [76.2]		198 [89.6]		206 [93.4]
Operating weight - lbs. [kg]		139 [63.0]			150 [68.0]		180 [81.6]		188 [85.3]

1/31/2017

## Model Nomenclature - Coil



## Refrigerant Coil Compatibility

Encased/Uncased Coil	Indoor Split Model (Single)	Indoor Split Model (Dual Capacity)	Outdoor Split Model (Dual Capacity)	Recommended Airflow (CFM)
SR**026C*	022	-	-	800
SR**026C*	-	026	026	850
SR**026C*	030	-	-	1000
SR**036C*	036	-	-	1200
SR**036C*	-	038	038	1200
SR**048C*	042	-	-	1300
SR**048C*	048	-	-	1500
SR**048C*	-	049	049	1500
SR**060C*	060	-	-	1800
SR**060C*	-	064	064	1800
SR**060C*	070	-	-	2000
SR**060C*	-	072	072	2000

1/10/2017

## SR Coil Physical Characteristics

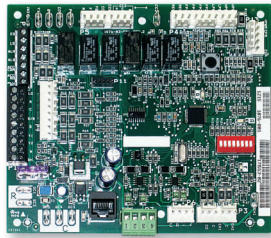
Air Handler Model Number (Refrigerant)		026			036		048		060	
<b>Evaporator Coil</b>	Air Coil Total Face Area, ft <sup>2</sup> [m <sup>2</sup> ]	3.89 [0.36]			4.86 [0.45]		5.83 [0.54]		6.81 [0.63]	
	Tube outside diameter - in. [mm]	3/8 [9.52]								
	Number of rows	3								
	Fins per inch	12								
	Suction line connection - in. [mm] sweat	5/8 [15.87]			3/4 [19.05]			7/8 [22.23]		
	Liquid line connection - in. [mm] sweat	3/8 [9.52]						1/2 [12.7]		
Refrigerant	R-410a									
Nominal cooling capacity - tons [kW]	1.8 [6.44]	2.1 [7.59]	2.5 [8.79]	3 [10.55]	3.5 [12.30]	4 [14.06]	5 [17.58]	5.5 [19.33]		
Condensate drain connection - (FPT) in. [mm]	3/4 [19.05]									
Filter Standard - 1" [51mm] Field Supplied.	16 X 20 [406 X 508]			20 X 20 [508 X 508]			22 X 20 [559 X 508]			

3/7/17

# The Aurora™ Control System

## Aurora ‘Base’ Control

The Aurora ‘Base’ Control (ABC) System is a complete residential and commercial comfort system that brings all aspects of the HVAC system into one cohesive module network. The ABC features microprocessor control and HP, LP, condensate (with AHB in air handler) and freeze detection, over/under voltage faults, along with communicating thermostat capability for complete fault detection text at the thermostat.



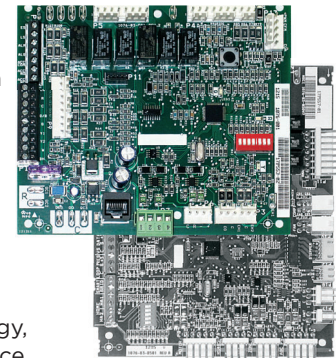
Aurora uses the Modbus communication protocol to communicate between modules. Each module contains the logic to control all features that are connected to the module. The Aurora ‘Base’ Control (ABC) has two Modbus channels. The first channel is configured as a master for connecting to devices such as a communicating thermostat, expansion board, or other slave devices. The second channel is configured as a slave for connecting the Aurora Interface Diagnostics Tool (AID Tool).

NOTE: The software on the ABC and AXB control boards is unique to the operation of the Geo-Split. Refer to the AURORA Toolbox for the current software versions.

## Aurora ‘Advanced’ Control

The Aurora ‘Advanced’ Control expands on the capability of the Aurora ‘Base’ Control (ABC) System by adding the Aurora Expansion Board (AXB).


The additional features include compressor current monitoring, loop pump linking, intelligent hot water generator control, variable speed pump capability, and also allows for optional energy, refrigeration, and performance monitoring factory installed add-on sensor kits. The AXB also features a second field configurable accessory relay, and two home automation inputs that are AID configurable for different types of alarms from sump pumps to home security. The Smart Grid input is AID configurable with many options to react to Utility controlled relay operation for ON Peak optimization. For IntelliZone2 compatibility the SAH Air Handler must have control option C (AHB Board) or the compressor section must have an AXB board. IntelliZone2 may be connected to P7 on either the AXB or AHB boards.








Aurora Control Features	Description	Aurora ‘Base’	Aurora ‘Advanced’
<b>Microprocessor Compressor Control</b>	Microprocessor control of compressor for timings with FP1, HP, LP, Condensate, assignable Acc relay	•	•
<b>Advanced Microprocessor Features</b>	Smart Grid, Home Automation Alarm Inputs, and Accessory2 Relay (HRV/ERV)	-	•
<b>Base Hot Water Generator Operation</b>	Compressor Contactor powers Hot Water Generator Pump with inline circuit breaker and thermostat limit.	•	See below
<b>Advanced Hot Water Generator Control</b>	Microprocessor and separate power relay for Hot Water Generator Pump with digital temperature monitoring and multiple HWG setpoint selection.	-	•
<b>Base Loop Pump Control</b>	Compressor Contactor powers Loop Pump with inline circuit breaker and no loop pump linking capability.	•	See below
<b>Advanced Speed Pump Control</b>	Microprocessor and separate power relay for loop pump and inline circuit breakers and loop pump linking.	-	•
<b>Variable Speed Pump</b>	Capable of setup, monitoring and controlling a variable speed flow center.	-	•
<b>Compressor Monitoring</b>	Control monitors compressor starts for high current, missing leg etc.	-	•
<b>Smart Grid/Utility Input</b>	Allows simple input to externally enable of occupied/unoccupied mode for basic utility time of use programs.	-	Dry Contact x1
<b>Home Automation Alarm Input</b>	Allows simple input to signal sump, security, or smoke/CO sensor alarms from other home automation or security systems. The two inputs can be field configured to a number of options and logic.	-	Dry Contactx2
<b>HAN/Smart Grid Com (AWL and Portal) Kit</b>	Allows direct communication of the Aurora to Smart Meters, Home Automation Network and Internet.	-	Optional AWL
<b>IntelliZone2® Compatibility</b>	IntelliZone2 communicates Modbus to the heat pump via the AXB or AHB boards.	With Optional AXB Kit and IntelliZone2	Optional IntelliZone2
<b>IntelliZone2 • 24V Compatibility</b>	Communicates to the heat pump via 24VAC (AXB and AHB not required)	•	-



## The Aurora Control System cont.

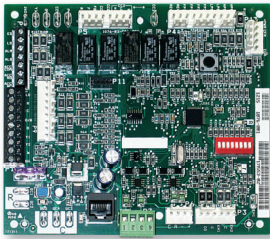
Service Device	Description	Aurora 'Base'	Aurora 'Advanced'
 <p><b>Aurora Interface and Diagnostics (AID) Tool</b></p>	<p>Allows setup, monitoring and troubleshooting of any Aurora Control.</p> <p><b>NOTE:</b> Although the ABC has basic compatibility with all Aurora, new product features may not be available on older AID Tools. To simplify the basic compatibility ensure the version of AID is at least the same or greater than the ABC software version.</p>	For Service (Ver. 1.xx or greater)	For Service (Ver. 2.xx or greater)

Add On Control Feature Kits (field or factory installed)	Description	Aurora 'Base'	Aurora 'Advanced'
<b>Geo Energy Monitoring Kit</b>	Monitors realtime power consumption of compressor, blower, aux heat and pump. Requires thermostat TPCM32UO3A*, TPCM32UO4A*, or TPCC32UO1*. AXB required. AHB required in air handler for blower and auxiliary heat power consumption monitoring.	-	Standard
<b>Refrigeration Monitoring Kit</b>	Monitors realtime pressures, temperatures, superheat, and subcooling. AXB required. AHB required in air handler for LAT (leaving air temperature).	-	Optional Sensor Kit
<b>Performance Monitoring Kit</b>	Monitors air and water temperatures, and water flow rate and calculates heat of extraction/rejection. AXB required.	-	Optional Sensor Kit
<b>Data Logging (AWL) Kit</b>	Allows data logging of up to 12 months. AXB required. Can also be temporarily installed.	-	Optional
<b>HAN/Smart Grid Com (AWL and Portal) Kit</b>	Allows direct communication of the Aurora to Smart Meters, HAN, and internet. AXB required.	-	Optional
<b>AXB Kit</b> for advanced hot water generator control, flow center linking, variable speed pump, IntelliZone2	Added for key features of advanced hot water generator control, advanced loop control/linking, IntelliZone2 communication, and variable speed pump control.	Optional (Field Kit)	Standard

Add On Thermostats and Zoning	Description	Aurora 'Base'	Aurora Advanced
 <p><b>TP32U03/04* - MonoChrome Traditional Y1, Y2 Thermostat</b></p>	Elite Stat with full English fault codes and alerts, traditional Y1, Y2 thermostat. Not compatible with AWL.	Optional	Optional
 <p><b>TP32S01/02* - Traditional Y1, Y2 Thermostat</b></p>	Traditional Y1, Y2 thermostat. Not compatible with AWL.	Optional	Optional
 <p><b>TPCM32U03A/04A* - MonoChrome Communicating Thermostat</b></p>	Elite Stat with full English fault codes and alerts, communicating thermostat. Monochrome thermostat allows instantaneous energy measurement only. Compatible with AWL.	Optional	Optional
 <p><b>TPCC32U01* - Color Touchscreen Communicating Thermostat</b></p>	4.3 in. color touchscreen communicating thermostat with full English fault codes and alerts. Color thermostat allows instantaneous energy measurement and 13 month energy usage history. Compatible with AWL.	Optional	Optional
<b>IntelliZone2 • 24V Zoning Compatibility</b>	IntelliZone2 • 24V is a non-communicating zoning system requiring Y1, Y2 signals that controls up to 4 zones (dual capacity) and 2 zones (single speed.) For systems without the optional AXB and AHB boards.	Optional (5-Speed ECM)	Optional (IntelliZone2 Preferred)
 <p><b>IntelliZone2® Zoning</b></p>	IntelliZone2® is a communicating zoning system that includes color main thermostat and up to 6 zones (with variable speed, 4 zones (with dual capacity), and 2 zones (with single speed). There are 4 thermostat options (MasterStat, TPCC32U01*, SensorStat, ZoneStat). Compatible with AWL. System must have either AXB or AHB board.	-	Optional (IntelliZone2 Preferred)

## The Aurora ‘Base’ Control System cont.

### Aurora ‘Base’ Control



**NOTE:** Refer to the Aurora Base Control Application and Troubleshooting Guide and the Instruction Guide: Aurora Interface and Diagnostics (AID) Tool for additional information.

### Control Features

#### Software ABC Geo-Split Version 3.0

#### Single or Dual Capacity Compressors

Either single or dual capacity compressors can be operated.

### Other Control Features

- Random start at power up
- Anti-short cycle protection
- High and low pressure cutouts
- Loss of charge
- Water coil freeze detection
- Over/under voltage protection
- Load shed
- Dehumidification (where applicable)
- Emergency shutdown
- Hot gas reheat operation (where applicable)
- Diagnostic LED
- Test mode push button switch
- Two auxiliary electric heat outputs
- Alarm output
- Accessory output with N.O. and N.C.
- Modbus communication (primary)
- Modbus communication (secondary)

### Field Selectable Options via Hardware

**DIP Switch (SW1)** – Test/Configuration Button (See SW1 Operation Table)

#### Test Mode

The control is placed in the test mode by holding the push button switch SW1 for 2 - 5 seconds. In test mode most of the control timings will be shortened by a factor of sixteen (16). LED3 (green) will flash at 1 second on and 1 second off. Additionally, when entering test mode LED1 (red) will flash the last lockout one time. Test mode will automatically time out after 30 minutes. Test mode can be exited by pressing and holding the SW1 button for 2 to 5 seconds or by cycling the power. **NOTE:** Test mode will automatically be exited after 30 minutes.

#### Reset Configuration Mode

The control is placed in reset configuration mode by holding the push button switch SW1 for 50 to 60 seconds. This will reset all configuration settings and the EEPROM back to the factory default settings. LED3 (green) will turn off when entering reset configuration mode. Once LED3 (green) turns off, release SW1 and the control will reset.

#### DIP Switch (SW2)

- SW2-1** FP1 Selection – Low water coil temperature limit setting for freeze detection. On = 30°F; Off = 15°F.
- SW2-2** FP2 Selection – On = 30°F; Off = N/A
- SW2-3** RV – O/B - thermostat type. Heat pump thermostats with “O” output in cooling or “B” output in Heating can be selected. On = O; Off = B.
- SW2-4** Access Relay Operation (P2)  
**and 2-5**

Access Relay Operation	SW2-4	SW2-5
Cycle with Blower	ON	ON
Cycle with Compressor	OFF	OFF
Water Valve Slow Opening	ON	OFF
Cycle with Comm. T-stat Hum Cmd	OFF	ON

## The Aurora 'Base' Control System cont.

**Cycle with Blower** - The accessory relay will cycle with the blower output.

**Cycle with Compressor** - The accessory relay will cycle with the compressor output.

**Water Valve Slow Opening** - The accessory relay will cycle and delay both the blower and compressor output for 90 seconds.

**SW2-6** CC Operation - selection of single or dual capacity compressor. On = Single Stage; Off = Dual Capacity

**SW2-7** Lockout and Alarm Outputs (P2) - selection of a continuous or pulsed output for both the LO and ALM Outputs. On = Continuous; Off = Pulsed

**SW2-8** Future Use

### Alarm Jumper Clip Selection

From the factory, ALM is connected to 24 VAC via JW2. By cutting JW2, ALM becomes a dry contact connected to ALG.

### Safety Features

The following safety features are provided to protect the compressor, heat exchangers, wiring and other components from damage caused by operation outside of design conditions.

**Fuse** - a 3 amp automotive type plug-in fuse provides protection against short circuit or overload conditions.

**Anti-Short Cycle Protection** - 4 minute anti-short cycle protection for the compressor.

**Random Start** - 5 to 80 second random start upon power up.

**Fault Retry** - in the fault condition, the control will stage off the outputs and then "try again" to satisfy the thermostat Y input call. Once the thermostat input calls are satisfied, the control will continue on as if no fault occurred. If 3 consecutive faults occur without satisfying the thermostat Y input call, then the control will go to Lockout mode.

**Lockout** - when locked out, the blower will operate continuously in "G" speed, and PSC blower motor output will remain on. The Alarm output (ALM) and Lockout output (L) will be turned on. The fault type identification display LED1 (Red) shall flash the fault code. To reset lockout conditions with SW2-8 On, thermostat inputs "Y1", "Y2", and "W" must be removed for at least 3 seconds. To reset lockout conditions with SW2-8 Off, thermostat inputs "Y1", "Y2", "W", and "DH" must be removed for at least 3 seconds. Lockout may also be reset by turning power off for at least 30 seconds or by enabling the emergency shutdown input for at least 3 seconds.

**Lockout With Emergency Heat** - if the control is locked out in the heating mode, and a Y2 or W input is received, the control will operate in the emergency heat mode while the compressor is locked out. The first emergency heat output will be energized 10 seconds after the W input is received, and the blower will shift to high speed. If the control remains locked out, and the W input is present, additional stage of emergency heat will stage on after 2 minutes. When the W input is removed, all of the emergency heat outputs will turn off, and the ECM blower will shift to "G" speed and PSC blower motor output will remain on.

**High Pressure** - fault is recognized when the Normally Closed High Pressure Switch, P4-9/10 opens, no matter how momentarily. The High Pressure Switch is electrically in series with the Compressor Contactor and serves as a hard-wired limit switch if an overpressure condition should occur.

**Low Pressure** - fault is recognized when the Normally Closed Low Pressure Switch, P4-7/8 is continuously open for 30 seconds. Closure of the LPS any time during the 30 second recognition time restarts the 30 second continuous open requirement. A continuously open LPS shall not be recognized during the 2 minute startup bypass time.

**Loss of Charge** - fault is recognized when the Normally Closed Low Pressure Switch, P4-7/8 is open prior to the compressor starting.

**Freeze Detection (Coax)** - set points shall be either 30°F or 15°F. When the thermistor temperature drops below the selected set point, the control shall begin counting down the 30 seconds delay. If the thermistor value rises above the selected set point, then the count should reset. The resistance value must remain below the selected set point for the entire length of the appropriate delay to be recognized as a fault. This fault will be ignored for the initial 2 minutes of the compressor run time.

## The Aurora 'Base' Control System cont.

**Over/Under Voltage Shutdown** - An over/under voltage condition exists when the control voltage is outside the range of 18 VAC to 30 VAC. If the over/under voltage shutdown lasts for 15 minutes, the lockout and alarm relay will be energized. Over/under voltage shutdown is self-resetting in that if the voltage comes back within range of 18 VAC to 30 VAC for at least 0.5 seconds, then normal operation is restored.

### Operation Description

**Power Up** - The unit will not operate until all the inputs and safety controls are checked for normal conditions. The unit has a 5 to 80 second random start delay at power up. Then the compressor has a 4 minute anti-short cycle delay after the random start delay.

**Standby** In standby mode, Y1, Y2, W, DH, and G are not active. Input O may be active. The blower and compressor will be off.

### Heating Operation

**Heating, 1st Stage (Y1) - (Single/Dual Capacity Compressor and Variable Speed ECM)** The blower is started on "G" speed immediately and the compressor is energized 10 seconds after the Y1 input is received. The ECM blower motor is switched to low speed 15 seconds after the Y1 input.

**Heating, 1st Stage (Y1) - (Single/Dual Capacity Compressor and 5 Speed ECM)** The blower is started on "Y1" speed immediately and the compressor is energized 10 seconds after the Y1 input is received.

**Heating, 2nd Stage (Y1, Y2) (Single/Dual Capacity Compressor and Variable Speed ECM)** - The compressor will be staged to full capacity 20 seconds after Y2 input is received. The ECM blower will shift to high speed 15 seconds after the Y2 input is received.

**Heating, 2nd Stage (Y1, Y2) (Single/Dual Capacity Compressor and 5 Speed ECM)** - The compressor will be staged to full capacity 20 seconds after Y2 input is received. The 5 speed ECM blower will shift to Y2 speed immediately.

**Heating, 3rd Stage (Y1, Y2, W) (Single/Dual Capacity Compressor and Variable Speed ECM)** - The hot water pump is de-energized and the first stage of electric heat is energized 10 seconds after the W command is received. If the demand continues the second stage of electric heat will be energized after 5 minutes.

**Heating, 3rd Stage (Y1, Y2, W) (Single/Dual Capacity Compressor and 5 Speed ECM)** - The first stage of electric heat is energized 10 seconds after the W command is received. Blower will increase to "W" speed immediately. If the demand continues the second stage of electric heat will be energized after 5 minutes.

**Emergency Heat (W)** - The blower will be started on "G" speed, 10 seconds later the first stage of electric heat will be turned on. 5 seconds after the first stage of electric heat is energized the blower will shift to Aux speed. If the emergency heat demand is not satisfied after 2 minutes the second electric heat stage will be energized.

### Cooling Operation

In all cooling operations, the reversing valve directly tracks the O input. Thus, anytime the O input is present, the reversing valve will be energized.

**Cooling, 1st Stage (Y1, O) (Single/Dual Capacity Compressor and Variable Speed ECM)** - The blower is started on "G" speed immediately and the compressor is energized 10 seconds after the Y1 input is received. The ECM blower motor is switched to low speed 15 seconds after the Y1 input.

**Cooling, 1st Stage (Y1, O) (Single/Dual Capacity Compressor and 5 Speed ECM)** - The blower is started on "Y1" speed immediately and the compressor is energized 10 seconds after the Y1 input is received.

**Cooling, 2nd Stage (Y1, Y2, O) (Single/Dual Capacity Compressor and Variable Speed ECM)** - The compressor will be staged to full capacity 20 seconds after Y2 input is received. The ECM blower will shift to high speed 15 seconds after the Y2 input is received.

**Cooling, 2nd Stage (Y1, Y2, O) (Single/Dual Capacity Compressor and 5 Speed ECM)** - The compressor will be staged to full capacity 20 seconds after Y2 input is received. The 5 speed ECM blower will shift to Y2 speed immediately.

**Emergency Shutdown** - Four (4) seconds after a valid ES input, P2-7 is present, all control outputs will be turned off and remain off until the emergency shutdown input is no longer present. The first time that the compressor is started after the control exits the emergency shutdown mode, there will be an anti-short cycle delay followed by a random start delay. Input must be tied to common to activate.

**Load Shed** - The LS input disables all outputs with the exception of the blower output. When the LS input has been cleared, the anti-short cycle timer and random start timer will be initiated. Input must be tied to common to activate.

# The Aurora 'Base' Control System cont.

## Aurora 'Base' Control LED Displays

These three LEDs display the status, configuration, and fault codes for the control. These can also be read in plain English via the Aurora AID Tool.

### Status LED (LED3, Green)

Description of Operation	Fault LED, Green
Normal Mode	ON
Control is Non-functional	OFF
Test Mode	Slow Flash
Lockout Active	Fast Flash
Dehumidification Mode	Flash Code 2
(Future Use)	Flash Code 3
(Future Use)	Flash Code 4
Load Shed	Flash Code 5
ESD	Flash Code 6
(Future Use)	Flash Code 7

### Configuration LED (LED2, Yellow)

Description of Operation	Configuration LED, Yellow
No Software Overwritten	Flashing ECM Setting
DIP Switch was Overwritten	Slow Flash
ECM Configuration Mode	Fast Flash

### Fault LED (LED1, Red)

Red Fault LED	LED Flash Code*	Lockout	Reset/Remove
Normal - No Faults	OFF	-	
Fault - Input	1	No	Auto
Fault - High Pressure	2	Yes	Hard or Soft
Fault - Low Pressure	3	Yes	Hard or Soft
Fault - Freeze Detection FP2	4	Yes	Hard or Soft
Fault - Freeze Detection FP1	5	Yes	Hard or Soft
Fault - Condensate Overflow	7	Yes	Hard or Soft
Fault - Over/Under Voltage	8	No	Auto
Fault - FP1 Sensor Error	11	Yes	Hard or Soft
Fault - CritComErr	19	NO	Auto

**NOTE:** All codes >11 use long flash for tens digit and short flash for the ones digit. 20, 30, 40, 50, etc. are skipped.

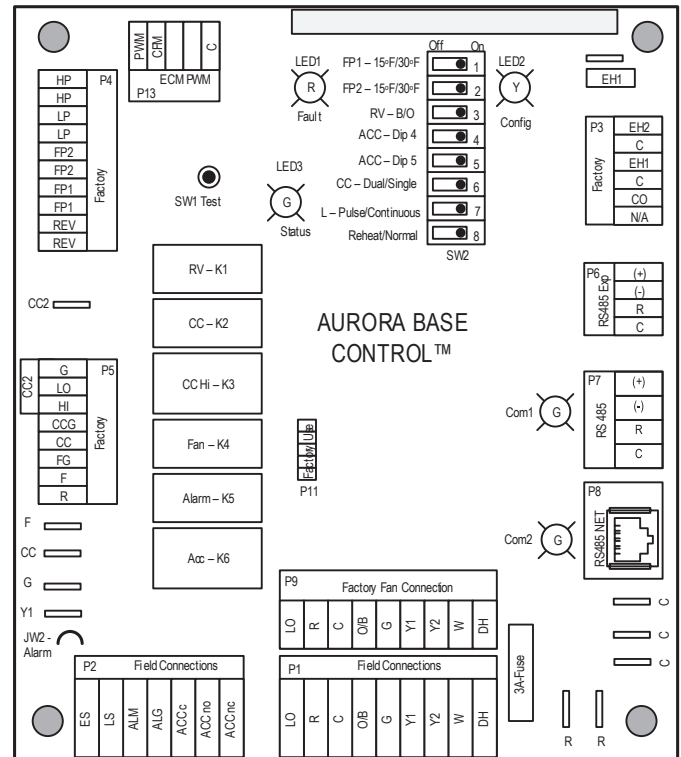
## Aurora Interface and Diagnostics (AID) Tool

The Aurora Interface and Diagnostics (AID) Tool is a device that is a member of the Aurora network.

The AID Tool is used to troubleshoot equipment which uses the Aurora control via Modbus RTU communication. The AID Tool provides diagnostics, fault management, variable speed ECM setup, and system configuration capabilities to the Aurora family of controls. An AID Tool is recommended, although not required, for ECM airflow settings. The AID Tool simply plugs into the exterior of the cabinet in the AID Tool port.



## ABC Control Board Layout

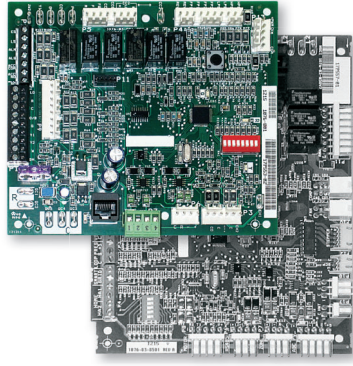


# The Aurora ‘Advanced’ Control System

## Aurora ‘Advanced’ Control Features

The Aurora ‘Advanced’ Control system expands on the capability of the Aurora ‘Base’ Control (ABC) by adding the Aurora Expansion Board (AXB).

All of the preceding features of the Aurora ‘Base’ Control are included. The following control description is of the additional features and capability of the Aurora advanced control.



It is highly recommended the installing/servicing contractor obtain an Aurora Interface and Diagnostic Tool (AID) and specialized training before attempting to install or service an Aurora ‘Advanced’ control system.



The additional AXB features include the following:

### AXB DIP Switch

**DIP 1 - ID:** This is the AXB ModBus ID and should always read On.

**DIP 2 & 3 - Future Use**

**DIP 4 & 5 - Accessory Relay2:** A second, DIP configurable, accessory relay is provided that can be cycled with the compressor 1 or 2 , blower, or the Dehumidifier (DH) input. This is to complement the Accessory 1 Relay on the ABC board.

Position	DIP 4	DIP 5	Description
1	ON	ON	Cycles with Fan or ECM (or G)
2	OFF	ON	Cycles with CC1 first stage of compressor or compressor spd 1-6
3	ON	OFF	Cycles with CC2 second stage of compressor or compressor spd 7-12
4	OFF	OFF	Cycles with DH input from ABC board

### Advanced Hot Water Generator Control (Domestic Hot Water Option)

In lieu of the ‘Base Hot Water Generator Control’, the Advanced features an AID Tool selectable temperature limit and microprocessor control of the process. This will maximize hot water generation and prevent undesirable energy use. An alert will occur when the hot water input temperature is at or above setpoint (100°F - 140°F) for 30 continuous seconds (130°F is the default setting). This alert will appear as an E15 on the AID Tool and the hot water pump de-energizes. Hot water pump operations resume on the next compressor cycle or after 15 minutes of continuous compressor operation during the current thermostat demand cycle. Since compressor hot

gas temperature is dependent on loop temperature in cooling mode, loop temperatures may be too low to allow proper heating of water. The control will monitor water and refrigerant temperatures to determine if conditions are satisfactory for heating water. LED1 (red LED) will flash code 15 when the DHW limit is reached and when conditions are not favorable for water heating. Error code 15 will also be displayed on the AID Tool in the fault screen. This flash code is a noncritical alert and does not necessarily indicate a problem.

### Compressor Monitoring

The AXB includes two current transducers to monitor the compressor current and starting characteristics. Open circuits or welded contactor faults will be detected. A fault will produce an E10 code.

### IntelliZone2 Zoning Compatibility (Optional IntelliZone2 Communicating Zoning)

A dedicated input to connect and communicate with the IntelliZone2 (IZ2) zoning system is necessary. With the split systems using the Aurora controls this can be accomplished by connecting the IZ2 to P7 on the compressor section AXB or P7 on the Air Handler AHB. These ports are dedicated for communicating proprietary ModBus protocol and only one of these boards is necessary for compatibility with the IZ2.

### AWL - Aurora Weblink (optional accessory)

AWL is an add-on WiFi router that connects to the ABC and offers many features:

- Remote access to thermostat settings, schedules, etc. with your smartphone, tablet or laptop
- Receive Lockout/Fault info via text or e-mail
- View heat pump energy usage from the Internet for the day, week, month, year or real-time
- Internet AID Tool capability allows remote troubleshooting for the technician
- Remote AID Tool capability at the heat pump with smartphone, tablet or laptop for the technician
- Allows data acquisition of the heat pump through the Internet, see graphs of performance and chart historical data for the technician
- Stores historical data on SD card

### Variable Speed Pump

This input and output are provided to drive and monitor a variable speed pump. The VS pump output is a PWM signal to drive the variable speed pump. The minimum and maximum level are set using the AID Tool. 75% and 100% are the default settings respectively. The VS data input allows a separate PWM signal to return from the pump giving fault and performance information. Fault received from the variable speed pump will be displayed as E16.

## The Aurora ‘Advanced’ Control System cont.

### Modulating Water Valve

This output is provided to drive a modulating water valve (only compatible with our 4MWVK or WWKVS) Through advanced design the 0-10VDC valve can be driven directly from the VS pump output. The minimum and maximum level are set in the same way as the VS pump using the AID Tool. 75% and 100% are the default settings respectively.

### Loop Pump Linking

This input and output are provided so that two units can be linked together with a common flow center. When either unit has a call for loop pump, both unit’s loop pump relays and variable speed pumps are energized. The flow center then can simply be wired to either unit. The output from one unit should be routed to the input of the other. If daisy chained up to 16 heat pumps can be wired and linked together in this fashion.

### Advanced Communication Ports

Communication ports P6 and P8 will provide future expansion via dedicated protocols. These are for future use.

### Smart Grid-On Peak (SG) Input

The ‘On Peak’ input was designed to allow utilities to utilize simple radio controlled switches to control the On Electric Peak behavior of the Geothermal Heat Pumps. With a closed contact signal, this input will limit the operation and thus the power consumption of the unit by one of the below selections. The AID Tool will allow configuration of this input for the action of:

- No Action
- Disable compressor operation until removed
- Go to On Peak thermostat settings until removed [Requires Com T-Stat] (Future Release)
- Compressor limited to 50% or low cap until removed [dual capacity or variable speed only] (Future Release)
- Disable compressor operation for 1/2 hr (can be removed immediately) (Future Release)

Then Flash Code 7 on the Green LED for the ‘On Peak’ mode. And On Peak will display on communicating thermostats.

### Home Automation 1 and 2 Inputs

The Home automation inputs are simple closed contact inputs that will trigger an AID Tool and thermostat alert for the homeowner. These would require optional sensors and or equipment for connection to the AXB board. With two inputs two different sensors can be selected. The selected text will then be displayed on the AID Tool and communicating thermostats. These events will NOT alter functionality or operation of the heat pump/accessories and is for homeowner/ service notification only.

#### Home Automation 1 - E23 HA1

With a closed dry contact signal, this input will cause an alarm and Alert Code 23 to indicate on the stat or flash on ABC. The AID Tool will allow configuration of this input between the following selections:

- No Action
- Home Automation Fault [no lockout info only]
  - Output from home automation system
- Security Alarm [no lockout info only]
  - Output from home security
- Sump Alarm Fault [no lockout info only]
  - Switch output from sump sensor
- Smoke/CO Alarm Fault [no lockout info only]
  - Switch output from Smoke/CO sensor
- Dirty Filter Alarm [no lockout info only]
  - Output from dirty filter sensor

#### Home Automation 2 - E24 HA2

With a closed dry contact signal, this input will cause an alarm and Alert Code 24 to indicate on the stat or flash on ABC. The AID Tool will allow configuration of this input between the following selections:

- No Action
- Home Automation Fault [no lockout info only]
  - Output from home automation system
- Security Alarm [no lockout info only]
  - Output from home security
- Sump Alarm Fault [no lockout info only]
  - Switch output from sump sensor
- Smoke/CO Alarm Fault [no lockout info only]
  - Switch output from Smoke/CO sensor
- Dirty Filter Alarm [no lockout info only]
  - Output from dirty filter sensor

## Monitoring Sensor Kits

### Energy Monitoring

#### (Standard Sensor Kit on ‘Advanced’ models)

The Energy Monitoring Kit uses the existing two compressor sensors so that the power usage of the heat pump can be measured. Control option ‘C’ in the SAH Series Air handler has the necessary sensors for measuring power consumption of the blower motor and auxiliary heat. So for viewing total power usage the compressor section will need control options B, C, or D and the SAH Series Air Handler will need to be ordered with control option C. The AID Tool provides configuration detail for the power adjustment and a line voltage calibration procedure to improve the accuracy, and a power adjustment setting that allows the compressor power to be adjusted to match the unit’s line voltage using the provided tables. This information can be displayed on the AID Tool or selected communicating thermostats. The TPCM32U03A\*/O4A\* will display instantaneous energy use while the color touchscreen TPCC32U01\* will in addition display a 13 month history in graph form. Refer to Unit Start Up Energy Monitoring for configuration details.

### Single Speed Power Adjustment

Model	Voltage		
	208	230	250
022	0.99	0.99	0.95
030	0.99	0.99	0.94
036	0.99	0.99	0.93
042	0.99	0.98	0.92
048	0.99	0.97	0.90
060	0.98	0.96	0.87
070	0.96	0.88	0.85

## The Aurora ‘Advanced’ Control System cont.

### Dual Capacity Power Adjustment

Model	Unit Capacity	Voltage		
		208	230	250
026	Full Load	0.99	0.99	0.96
	Part Load	0.99	0.99	0.93
038	Full Load	0.99	0.97	0.91
	Part Load	0.99	0.94	0.83
049	Full Load	0.94	0.91	0.85
	Part Load	0.91	0.84	0.75
064	Full Load	0.95	0.9	0.79
	Part Load	0.92	0.83	0.71
072	Full Load	0.94	0.86	0.73
	Part Load	0.92	0.81	0.65

### Refrigerant Monitoring (optional sensor kit)

The optional Refrigerant Monitoring Kit includes two pressure transducers, and two temperature sensors, heating liquid line, suction temperature and existing cooling liquid line (FP1). These sensors allow the measurement of discharge and suction pressures, suction and liquid line temperatures as well as superheat and subcooling. This information will only be displayed on the AID Tool.

### Performance Monitoring (optional sensor kit)

The optional Performance Monitoring Kit includes two temperature sensors, entering and leaving water and a water flow rate sensor. With this kit heat of extraction and rejection will be calculated. This requires configuration using the AID Tool for selection of water or antifreeze. The SAH Air Handler when ordered with control option C will include the LAT (leaving air temperature) sensor.

### Special Modes and Applications Communicating Digital Thermostats

The Aurora controls system also features either mono-chromatic or color touch screen graphic display thermostats for user interface. These displays not only feature easy to use graphical interface but display alerts and faults in plain English. Many of the features discussed here may not be applicable without these thermostats.

### Aurora ‘Advanced’ Control LED Displays

These three LEDs display the status, configuration, and fault codes for the control. These can also be read in plain English via the Aurora AID Tool.

#### Status LED (LED3, Green)

Description of Operation	Fault LED, Green
Normal Mode	ON
Control is Non-functional	OFF
Test Mode	Slow Flash
Lockout Active	Fast Flash
Dehumidification Mode	Flash Code 2
Load Shed	Flash Code 5
Emergency Shutdown	Flash Code 6
On Peak Mode	Flash Code 7
(Future Use)	Flash Code 8
(Future Use)	Flash Code 9

#### Configuration LED (LED2, Yellow)

Description of Operation	Configuration LED, Yellow
No Software Overwritten	ECM Setting
DIP Switch Overwritten	Slow Flash
ECM Configuration Mode	Fast Flash
Reset Configuration Mode	OFF

### Fault LED (LED1, Red)

Red Fault LED	LED Flash Code *	Lockout	Reset/ Remove	Fault Condition Summary
Normal - No Faults	Off	-		
<b>ABC Basic Faults</b>				
Fault-Input	1	No	Auto	Tstat input error. Autoreset upon condition removal.
Fault-High Pressure	2	Yes	Hard or Soft	HP switch has tripped (>600 psi)
Fault-Low Pressure	3	Yes	Hard or Soft	Low Pressure Switch has tripped (<40 psi for 30 continuous sec.)
Fault-Freeze Detection FP2	4	Yes	Hard or Soft	Freeze protection sensor has tripped (<15 or 30 degF for 30 continuous sec.)
Fault-Freeze Detection FP1	5	Yes	Hard or Soft	Freeze protection sensor has tripped (<15 or 30 degF for 30 continuous sec.)
Fault-Condensate Overflow	7	Yes	Hard or Soft	Condensate switch has shown continuity for 30 continuous sec.
Fault-Over/Under Voltage	8	No	Auto	Instantaneous voltage is out of range. **Controls shut down until resolved.
Fault-FP1 Sensor Error	11	Yes	Hard or Soft	FP1 Sensor Open or Shorted
<b>ABC &amp; AXB Advanced</b>				
Fault-Compressor Monitor	10	Yes	Hard or Soft	Open Crkt, Run, Start or welded cont
Non-CriticAXB SnsrErr	13	No	Auto	Any Other Sensor Error
CriticAXBSnsrErr	14	Yes	Hard or Soft	Sensor Error for EEV or HW
Alert-HotWtr	15	No	Auto	HW over limit or logic lockout. HW pump deactivated.
Fault-VarSpdPump	16	No	Auto	Alert is read from PWM feedback.
Non-CritComErr	18	No	Auto	Any non-critical com error
Fault-CritComErr	19	No	Auto	Any critical com error. Auto reset upon condition removal
Alarm - Low Loop Pressure	21	No	Auto	Loop pressure is below 3 psi for more than 3 minutes
Alarm - Home Automation 1	23	No	Auto	Closed contact input is present on Dig 2 input - Text is configurable
Alarm - Home Automation 2	24	No	Auto	Closed contact input is present on Dig 3 input - Text is configurable

#### NOTES:

\*All codes >11 use long flash for tens digit and short flash for the ones digit. 20, 30, 40, 50 etc. are skipped!

Alert\* is a noncritical sensor or function that has failed. Normal operation of the heat pump is maintained but service is desired at some point.



## Reference Calculations

Heating Calculations:	Cooling Calculations:
$LWT = EWT - \frac{HE}{gpm \times 500}$	$LWT = EWT + \frac{HR}{gpm \times 500}$
$LAT = EAT + \frac{HC}{cfm \times 1.08}$	$LAT (DB) = EAT (DB) - \frac{SC}{cfm \times 1.08}$
$TH = HC + HW$	$LC = TC - SC$
	$S/T = \frac{SC}{TC}$

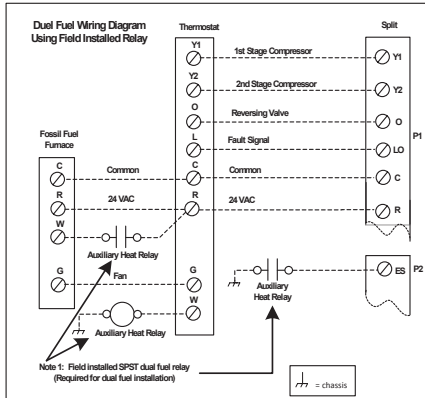
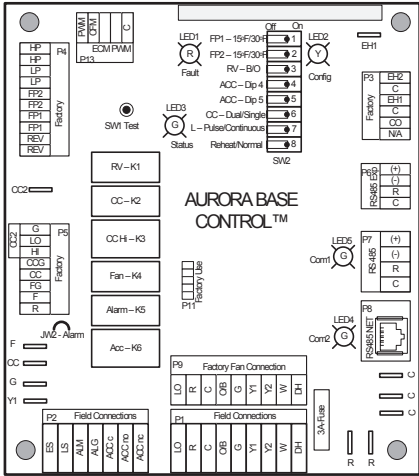
## Legend

### Abbreviations and Definitions

cfm = airflow, cubic feet/minute	HWC = hot water generator capacity, MBtu/h
EWT = entering water temperature, Fahrenheit	EER = Energy Efficient Ratio
gpm = water flow in gallons/minute	= Btu output/Watt input
WPD = water pressure drop, psi and feet of water	COP = Coefficient of Performance
EAT = entering air temperature, Fahrenheit (dry bulb/wet bulb)	= Btu output/Btu input
HC = air heating capacity, MBtu/h	LWT = leaving water temperature, °F
TC = total cooling capacity, MBtu/h	LAT = leaving air temperature, °F
SC = sensible cooling capacity, MBtu/h	TH = total heating capacity, MBtu/h
kW = total power unit input, kilowatts	LC = latent cooling capacity, MBtu/h
HR = total heat of rejection, MBtu/h	S/T = sensible to total cooling ratio
HE = total heat of extraction, MBtu/h	

# Wiring Schematics

## Split Wiring Schematic - 208-230/60/1

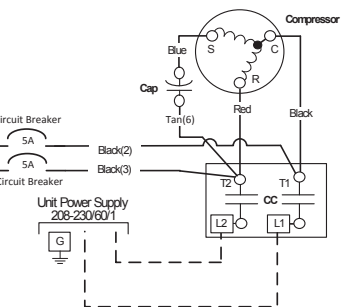
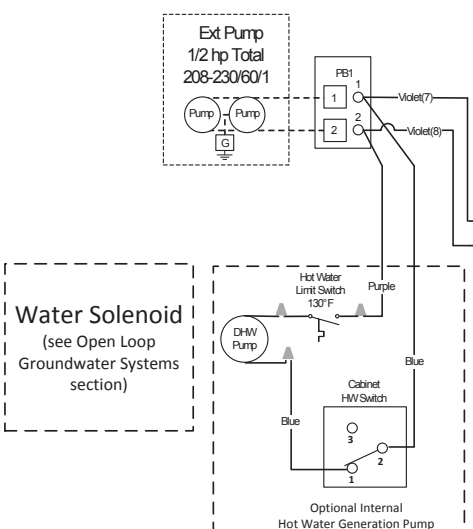


### Legend

	Factory Low voltage wiring		Thermistor
	Factory Line voltage wiring		Light emitting diode - Green
	Field low voltage wiring		Relay coil
	Field line voltage wiring		Capacitor w/ bleed resistor
	Optional block		Switch - Condensate overflow
	DC Voltage PCB traces		Switch - High pressure
	Junction		Switch - Low pressure
	Quick connect terminal		Polarized connector
	Wire nut		Power block
	Field wire lug		Power strip
	Ground		Reversing Valve coil
	Relay Contacts N.O., N.C.		DIP package 5 position AxB
	Fuse		TEST MODE ABC Board
	Breaker		DIP package 8 position ABC Board
	Compressor Contactor		Thermal limit switch
	Condensate overflow sensor		Hot water limit sensor
	DHW pump relay		Start Contactor
	Loop pump relay		Water Valve Slow Open Delay
	PSC Fan Speed Relay		
	PSC Fan Power Relay		
	Compressor Solenoid		
	Fuses		
	Heater element		
	High pressure switch		
	Freeze protection sensor		
	Low pressure switch		

### Notes

1- Field installed SPST relay required for dual fuel applications

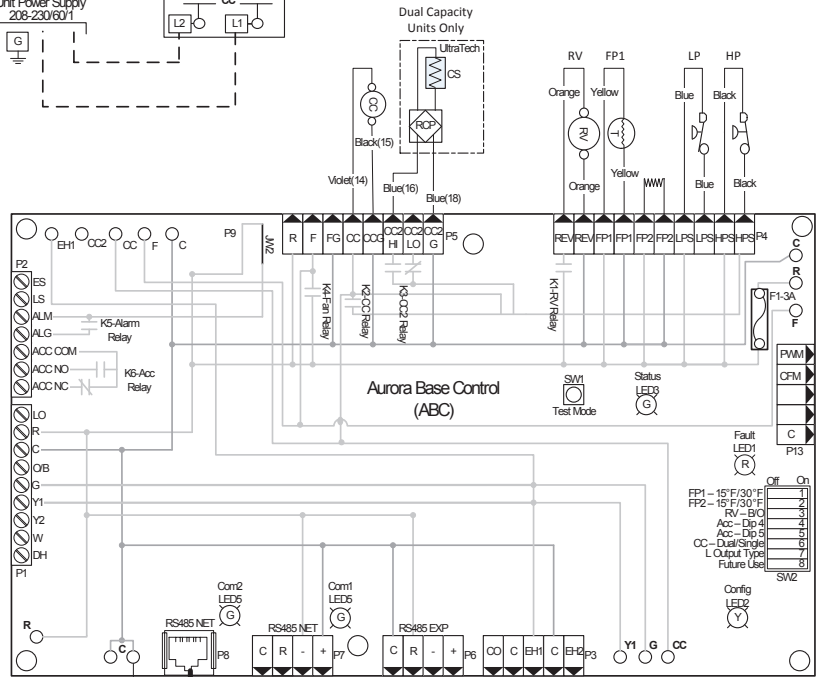


### Aurora Timing Events

Event	Normal Mode	Test Mode
Random Start Delay	5 to 80 seconds	1 second
Compressor On Delay	5 seconds	< 1 second
Compressor Minimum On Time	2 minutes	5 seconds
Compressor Short Cycle Delay	4 minutes	15 seconds
Blower Off Delay	30 seconds	2 seconds
Fault Recognition Delay - High Pressure	Less than 1 second	Less than 1 second
Start-Up Bypass - Low Pressure	2 minutes	30 seconds
Fault Recognition Delay - Low Pressure	30 seconds	30 seconds
Start-Up Bypass - Low Water Coil Limit	2 minutes	30 seconds
Fault Recognition Delay - Low Water Coil Limit	30 seconds	30 seconds
Fault Recognition Delay - Condensate Overflow	30 seconds	30 seconds
Thermostat Call Recognition Time	2 seconds	2 seconds
Water Valve Slow Open Delay	90 seconds	90 seconds

### ABC SW2 Accessory Relay

DESCRIPTION	SW2-4	SW2-5
Cycle with Blower	ON	ON
Cycle with Compressor	OFF	OFF
Water Valve Slow Opening	ON	OFF
Cycle with Comm. T-stat Hum Cmd	OFF	ON



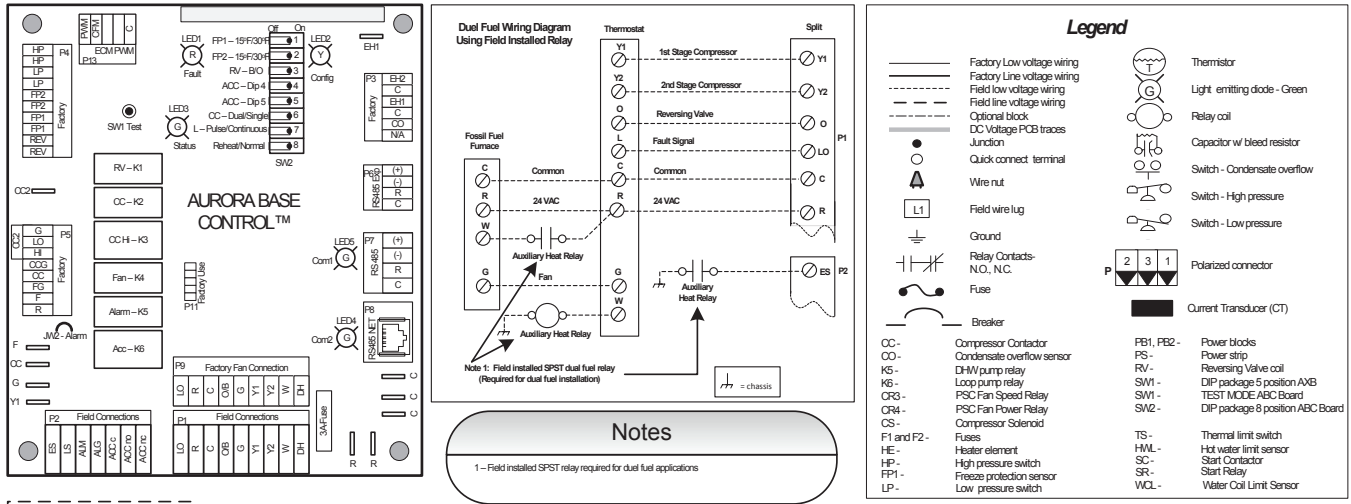
### Aurora LED Flash Codes

Flash Code	Description
Slow Flash	1 second on and 1 second off
Fast Flash	100 milliseconds on and 100 milliseconds off
Flash Code	100 milliseconds on and 400 milliseconds off with a 2 second pause before repeating
Random Start Delay (Alternating Colors)	
Status LED (LED1, Green)	Fast Flash
Configuration LED (LED2, Yellow)	Fast Flash
Fault LED (LED3, Red)	Fast Flash
Fault LED (LED1, Red)	
Normal Mode	OFF
Input Fault Lockout	Flash Code 1
High Pressure Lockout	Flash Code 2
Low Pressure Lockout	Flash Code 3
Future Use	Flash Code 4
Freeze Detection - FP1	Flash Code 5
Reserved	Flash Code 6
Condensate Overflow Lockout	Flash Code 7
Over/Under Voltage Shutdown	Flash Code 8
Future Use	Flash Code 9
Future Use	Flash Code 10
FP1 Sensor Error	Flash Code 11

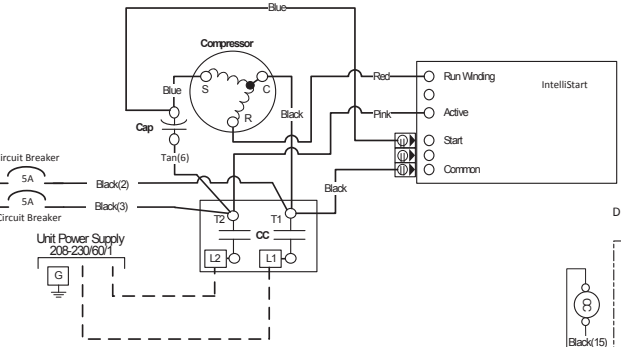
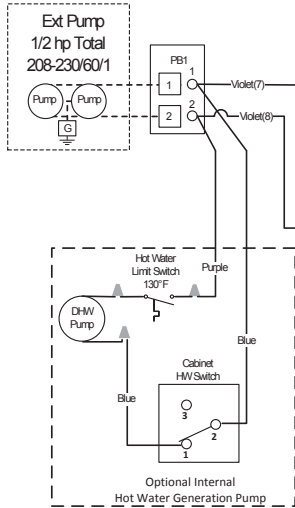


# Wiring Schematics cont.

## Split Wiring Schematic with IntelliStart - 208-230/60/1



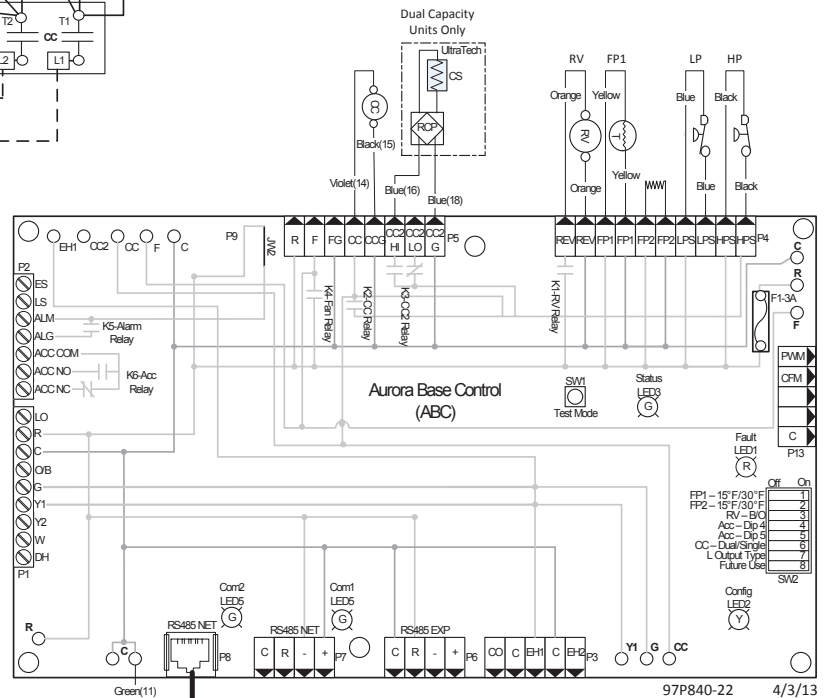
**Water Solenoid**  
(see Open Loop Groundwater Systems section)



Aurora Timing Events		
Event	Normal Mode	Test Mode
Random Start Delay	5 to 80 seconds	1 second
Compressor On Delay	5 seconds	< 1 second
Compressor Minimum On Time	2 minutes	5 seconds
Compressor Short Cycle Delay	4 minutes	15 seconds
Blower Off Delay	30 seconds	2 seconds
Fault Recognition Delay - High Pressure	Less than 1 second	Less than 1 second
Start-Up Bypass - Low Pressure	2 minutes	30 seconds
Fault Recognition Delay - Low Pressure	2 minutes	30 seconds
Start-Up Bypass - Low Water Coil Limit	2 minutes	30 seconds
Fault Recognition Delay - Low Water Coil Limit	30 seconds	30 seconds
Fault Recognition Delay - Condensate Overflow	30 seconds	30 seconds
Thermostat Call Recognition Time	2 seconds	2 seconds
Water Valve Slow Open Delay	90 seconds	90 seconds

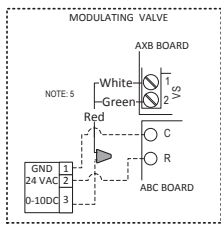
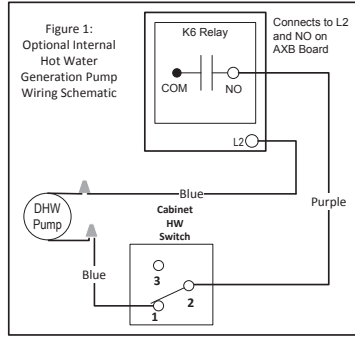
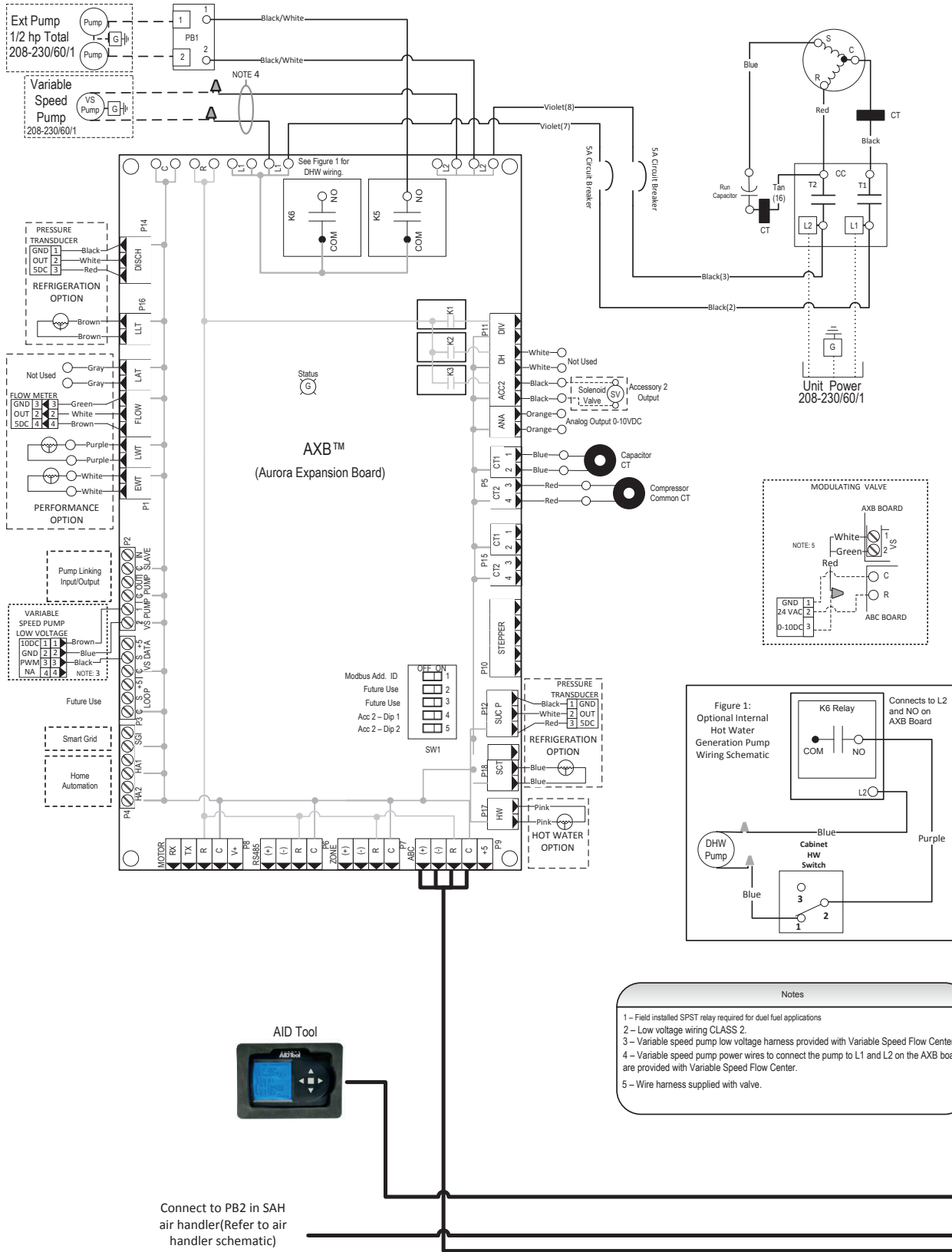
ABC SW2 Accessory Relay		
DESCRIPTION	SW2-4	SW2-5
Cycle with Blower	ON	ON
Cycle with Compressor	OFF	OFF
Water Valve Slow Opening	ON	OFF
Cycle with Comm. T-stat Hum Cmd	OFF	ON

Aurora LED Flash Codes			
Slow Flash	1 second on and 1 second off		
Fast Flash	100 milliseconds on and 100 milliseconds off		
Flash Code	100 milliseconds on and 400 milliseconds off with a 2 second pause before repeating		
Random Start Delay (Alternating Colors)		Configuration LED (LED2, Yellow)	
Status LED (LED1, Green)	Fast Flash	No Software Override	OFF
Configuration LED (LED2, Yellow)	Fast Flash	DIP Switch Override	Slow Flash
Fault LED (LED3, Red)	Fast Flash		
Fault LED (LED1, Red)		Status LED (LED3, Green)	
Normal Mode	OFF	Normal Mode	ON
Input Fault Lockout	Flash Code 1	Control is Non-Functional	OFF
High Pressure Lockout	Flash Code 2	Test Mode	Slow Flash
Low Pressure Lockout	Flash Code 3	Lockout Active	Fast Flash
Future Use	Flash Code 4	Dehumidification Mode	Flash Code 2
Freeze Detection - FP1	Flash Code 5	Future Use	Flash Code 3
Reserved	Flash Code 6	Future Use	Flash Code 4
Condensate Overflow Lockout	Flash Code 7	Load Shed	Flash Code 5
Over/Under Voltage Shutdown	Flash Code 8	ESD	Flash Code 6
Future Use	Flash Code 9	Future Use	Flash Code 7
Future Use	Flash Code 10		
FP1 Sensor Error	Flash Code 11		



# Wiring Schematics cont.

## Aurora Advanced Controls

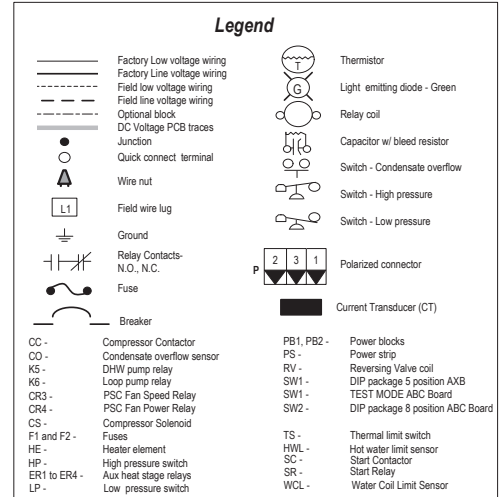
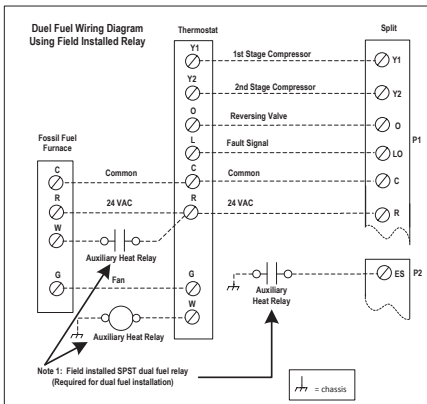
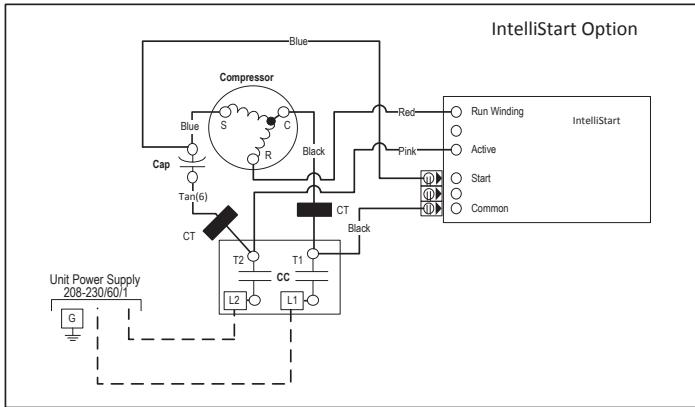


- Notes**
- 1 - Field installed SPST relay required for dual fuel applications
  - 2 - Low voltage wiring CLASS 2
  - 3 - Variable speed pump low voltage harness provided with Variable Speed Flow Center.
  - 4 - Variable speed pump power wires to connect the pump to L1 and L2 on the AXB board are provided with Variable Speed Flow Center.
  - 5 - Wire harness supplied with valve.

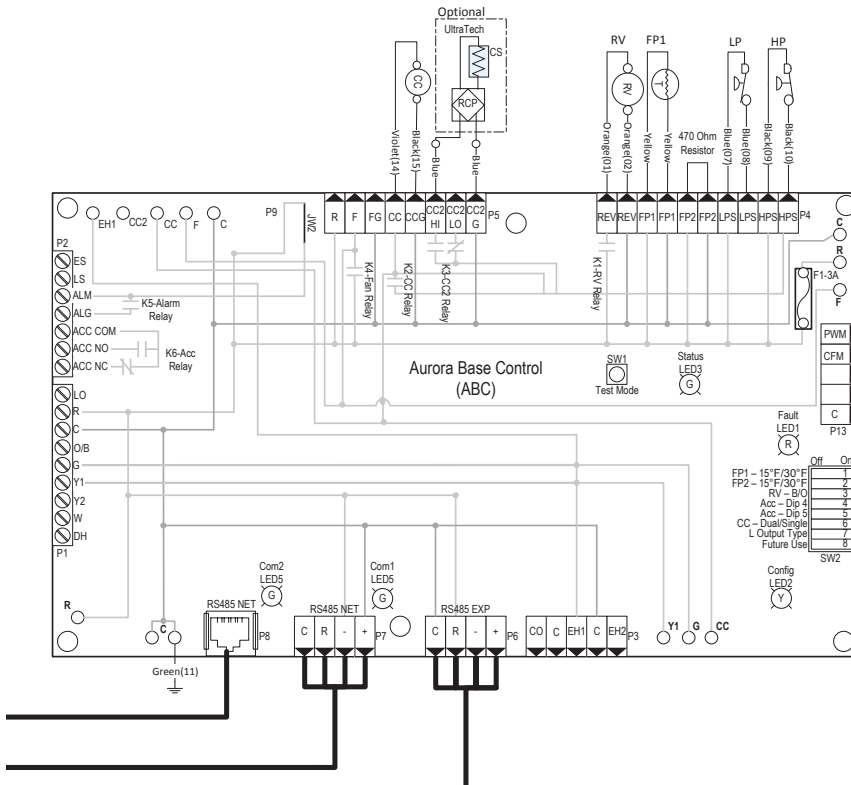


# Wiring Schematics cont.

## Aurora Advanced Controls



Aurora LED Flash Codes			
Slow Flash	1 second on and 1 second off		
Fast Flash	100 milliseconds on and 100 milliseconds off		
Flash Code	100 milliseconds on and 400 milliseconds off with a 2 second pause before repeating		
Random Start Delay (Alternating Colors)		Configuration LED (LED2, Yellow)	
Status LED (LED1, Green)	Fast Flash	No Software Override	OFF
Configuration LED (LED2, Yellow)	Fast Flash	DIP Switch Override	Slow Flash
Fault LED (LED3, Red)	Fast Flash		
Fault LED (LED1, Red)		Status LED (LED3, Green)	
Normal Mode	OFF	Normal Mode	ON
Input Fault Lockout	Flash Code 1	Control is Non-Functional	OFF
High Pressure Lockout	Flash Code 2	Test Mode	Slow Flash
Low Pressure Lockout	Flash Code 3	Lockout Active	Fast Flash
Future Use	Flash Code 4	Dehumidification Mode	Flash Code 2
Freeze Detection - FP1	Flash Code 5	Future Use	Flash Code 3
Reserved	Flash Code 6	Future Use	Flash Code 4
Condensate Overflow Lockout	Flash Code 7	Load Shed	Flash Code 5
Over/Under Voltage Shutdown	Flash Code 8	ESD	Flash Code 6
Future Use	Flash Code 9	Future Use	Flash Code 7
Future Use	Flash Code 10		
FP1 Sensor Error	Flash Code 11		

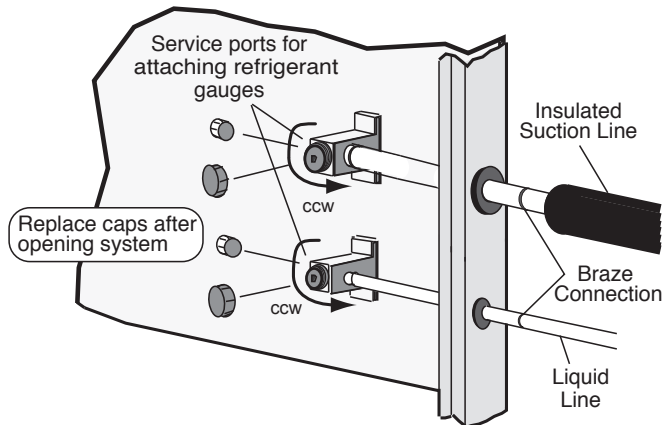


## Refrigeration

The Split series comes with a holding charge. The charge must be adjusted in the field based on performance. Refrigeration piping on the split consists of installing a brazed copper line set between the blower coil unit and the unit's split compressor section. To select the proper tube diameters for the installation, refer to the Line Set Sizes table. Line sets over 60 feet long are not recommended because of oil return and pressure drop problems. The suction line must always be insulated. Handle and route the line sets carefully to avoid kinking or bending the tubes. If the line set is kinked or distorted and it cannot be formed back into its original shape, the bad portion of the pipe should be replaced. A restricted line set will affect the performance of the system.

Fasten the copper line set to the blower coil unit as instructed by the coil installation instructions shown in

**Figure 13: Typical Split System Refrigerant Line Connections**

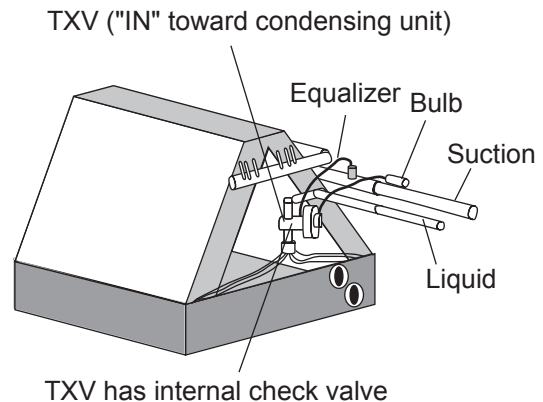


Position	Description	System	Service Port
CW - Full In	Shipping Position	Closed	Open
CCW - Full Out 1/2 turn CW	Service Position	Open	Open
CCW - Full Out	Operation Position	Open	Closed

Figure 14. Nitrogen should be bled through the system at 2 to 3 PSI to prevent oxidation inside the refrigerant tubing. Use a low silver phos-copper braze alloy on all brazed connections.

The geothermal indoor split service valves are recessed in the unit's corner post and protected by a cover. Remove the protective cover and braze the line set to the service valve stubs as shown in Figure 13. Care should be used when brazing the service valves as to not scorch the paint. Nitrogen should be bled through the system at 2 to 3 psi to prevent oxidation contamination. Use a low silver phos-copper braze alloy on all brazed connections. Geothermal split units are shipped with a factory charge and service valves are not to be opened until the line set has been leak tested, purged, and evacuated. Schrader cores should be removed before brazing, and replaced after the valves have cooled. A heat sink should be used on the service valve and TXV to prevent damage caused by excessive heat. When brazing is completed, reinstall the protective cover.

**Figure 14: Attaching the Air Coil**



## Refrigeration cont.

### Leak Testing

The refrigeration line set must be pressurized and checked for leaks before purging and charging the unit. To pressurize the line set, attach refrigerant gauges to the service ports and add an inert gas (nitrogen or dry carbon dioxide) until pressure reaches 60 to 90 PSIG. Never use oxygen or acetylene to pressure test. Use an electronic leak detector or a good quality bubble solution to detect leaks on all connections made in the field. Check the service valve ports and stem for leaks and all connections made in the field. If a leak is found, repair it and repeat the above steps. For safety reasons do not pressurize the system above 150 psi. Purge pressure from line set. The system is now ready for evacuating and charging.

### System Evacuation

Ensure that the line set and air coil are evacuated before opening service valves to the split unit. The line set must be evacuated to at least 200 microns to remove the moisture and air that may still be in the line set and coil. Evacuate the system through both service ports to prevent false readings on the gauge because of pressure drop through service ports.

### Charge Amount When Using SAH Air Handler

The Indoor Split is shipped with a factory pre-charge. This volume of refrigerant is not sufficient to run the system and additional refrigerant must be added. If using an SAH Air Handler please refer to the Line Set Sizes table for charge amounts to be added. The "Factory Charge" column is the charge amount the compressor section/split is shipped with from the factory. The "Charge Amount with SAH Air Handler" column is the total amount of charge for the SAH Air Handler + Compressor section/split. This column does not factor in additional refrigerant needed for the line set. The installer of the system must add charge appropriately for the specific length of the line set. A 3/8 in. liquid line is calculated at 0.50 oz. of charge per linear foot, and a 1/2 in. liquid line is calculated at 1.0 oz. of charge per linear foot using R-410A refrigerant. The suction line will not hold "liquid" and should be ignored for the charge calculation.

**Example:** Indoor Split \*036/SAH036 with 20 ft. of 3/8 in. liquid line. Remember that when using the SAH Air Handler, the column "Charge Amount with SAH Air Handler" will be used. Now calculate for the additional 20 ft. line set.  
 Additional refrigerant to be added = (20 ft. x 0.5 oz.)  
 = 10 oz.

**Solution:** 10 oz. should be added to the recommended charge of 86 oz. found in the "Charge Amount with SAH Air Handler" column for a total charge of 96 oz.

After initial charge, the system should be operated and the system subcooling and superheat verified to the Unit Operating Parameters table.

If an air handler manufactured by others is used then refrigerant should be added to the Indoor Split factory pre-charge. Refrigerant should be added for liquid line length. This should result in a slightly under-charged system exhibiting low subcooling and high superheat. As charge is added, the subcooling should rise and the superheat should fall.

### Charging the System

Charge Method - After purging and evacuating the line set, fully open the service valves counterclockwise. Add R-410A (liquid) into the liquid line service port until the pressure in the system reaches approximately 200 PSIG. Never add liquid refrigerant into the suction side of a compressor. Start the unit and measure superheat and subcooling. Keep adding refrigerant until the unit meets the superheat and subcooling values on the Operating Parameters tables.

### Checking Superheat and Subcooling Determining Superheat

1. Measure the temperature of the suction line at the point where the expansion valve bulb is clamped.
2. Determine the suction pressure in the suction line by attaching refrigeration gauges to the Schrader connection on the suction side of the compressor.
3. Convert the pressure obtained in Step 2 to the saturation temperature by using the R-410A Pressure/Temperature Conversion Chart.
4. Subtract the temperature obtained in Step 3 from Step 1. The difference is the amount of superheat for the unit. Refer to the Operating Parameters tables for superheat ranges at specific entering water conditions.

### Superheat Adjustment

TXVs are factory set to a specific superheat; however, the superheat should be adjusted for the application. To adjust the TXV to other superheat settings:

1. Remove the seal cap from the bottom of the valve.
2. Turn the adjustment screw clockwise to increase superheat and counterclockwise to decrease superheat. One complete 360° turn changes the superheat approximately 1-2°F, regardless of refrigerant type. You may need to allow as much as 30 minutes after the adjustment is made for the system to stabilize.
3. Once the proper superheat setting has been achieved, replace and tighten the seal cap.

## Refrigeration cont.



**WARNING: There are 12 total (360°) turns on the superheat adjustment stem from wide open to fully closed. When adjusting the superheat stem clockwise (superheat increase) and the stop is reached, any further clockwise turning adjustment will damage the valve.**

### Determining Subcooling

1. Measure the temperature of the liquid line on the small refrigerant line (liquid line) just outside the split cabinet. This location will be adequate for measurement in both modes unless a significant temperature drop in the liquid line is anticipated.
2. Measure the liquid line pressure by attaching refrigerant gauges to the Schrader connection on the liquid line service valve.
3. Convert the pressure obtained in Step 2 to the saturation temperature by using the R-410A Pressure/Temperature Conversion Chart.
4. Subtract the temperature in Step 1 from the temperature in Step 3. The difference will be the subcooling value for that unit. Refer to the Operating Parameters tables for subcooling ranges at specific enter water conditions.

## Line Set Sizes

Unit Size	Air Handler	20 feet		40 feet		60 feet		Split Factory Charge (oz.)	*Charge Amount with SAH Air Handler (oz.)
		Suction	Liquid	Suction	Liquid	Suction	Liquid		
022	SAH022	5/8" OD	3/8" OD	5/8" OD	3/8" OD	3/4" OD	3/8" OD	56	76
030	SAH030	5/8" OD	3/8" OD	3/4" OD	3/8" OD	3/4" OD	3/8" OD	56	82
036	SAH036	5/8" OD	3/8" OD	3/4" OD	3/8" OD	3/4" OD	1/2" OD	56	96
042	SAH042	3/4" OD	3/8" OD	3/4" OD	3/8" OD	7/8" OD	1/2" OD	74	104
048	SAH048	3/4" OD	3/8" OD	7/8" OD	3/8" OD	7/8" OD	1/2" OD	90	112
060	SAH060	7/8" OD	1/2" OD	7/8" OD	1/2" OD	1-1/8" OD	1/2" OD	92	119
070	SAH066	7/8" OD	1/2" OD	7/8" OD	1/2" OD	1-1/8" OD	1/2" OD	108	135
026	SAH026	5/8" OD	3/8" OD	3/4" OD	3/8" OD	3/4" OD	1/2" OD	52	72
038	SAH036	5/8" OD	3/8" OD	3/4" OD	3/8" OD	3/4" OD	1/2" OD	56	96
049	SAH048	3/4" OD	3/8" OD	7/8" OD	3/8" OD	7/8" OD	1/2" OD	90	112
064	SAH060	7/8" OD	1/2" OD	7/8" OD	1/2" OD	1-1/8" OD	1/2" OD	96	119
072	SAH066	7/8" OD	1/2" OD	7/8" OD	1/2" OD	1-1/8" OD	1/2" OD	104	133
<b>CAPACITY MULTIPLIER</b>		1.00		0.985		0.97			

Notes: \* The "Charge Amount with SAH Air Handler" column is based on the charge amount for a SAH Air Handler + Compressor Section/Split.

Additional charge will need to be added accordingly for line set length.

After charge is added, additional adjustments can be made to get appropriate subcooling and superheat measurements.

Additional charge for R410A is 0.50 oz. per ft. for 3/8" and 1.0 oz. per ft. for 1/2" tube.

Longer line sets will significantly reduce capacity and efficiency of the system as well as adversely effect the system reliability due to poor oil return.

1/13/2017



## Pressure/Temperature Conversion Chart for R-410A

PRESSURE (PSIG)	TEMP °F	PRESSURE (PSIG)	TEMP °F	PRESSURE (PSIG)	TEMP °F	PRESSURE (PSIG)	TEMP °F	PRESSURE (PSIG)	TEMP °F
60	8.5	180	63.5	300	96.3	420	120.6	540	140.0
62	9.9	182	64.2	302	96.8	422	120.9	542	140.3
64	11.2	184	64.8	304	97.2	424	121.3	544	140.6
66	12.5	186	65.5	306	97.7	426	121.6	546	140.9
68	13.8	188	66.1	308	98.1	428	122.0	548	141.2
70	15.1	190	66.8	310	98.6	430	122.3	550	141.4
72	16.3	192	67.4	312	99.0	432	122.7	552	141.7
74	17.5	194	68.0	314	99.5	434	123.0	554	142.0
76	18.7	196	68.7	316	99.9	436	123.4	556	142.3
78	19.8	198	69.3	318	100.4	438	123.7	558	142.6
80	21.0	200	69.9	320	100.8	440	124.1	560	142.9
82	22.1	202	70.5	322	101.2	442	124.4	562	143.2
84	23.2	204	71.1	324	101.7	444	124.8	564	143.5
86	24.3	206	71.7	326	102.1	446	125.1	566	143.7
88	25.4	208	72.3	328	102.5	448	125.4	568	144.0
90	26.5	210	72.9	330	103.0	450	125.8	570	144.3
92	27.5	212	73.5	332	103.4	452	126.1	572	144.6
94	28.6	214	74.1	334	103.8	454	126.5	574	144.9
96	29.6	216	74.7	336	104.2	456	126.8	576	145.1
98	30.6	218	75.3	338	104.7	458	127.1	578	145.4
100	31.6	220	75.8	340	105.1	460	127.5	580	145.7
102	32.6	222	76.4	342	105.5	462	127.8	582	146.0
104	33.5	224	77.0	344	105.9	464	128.1	584	146.2
106	34.5	226	77.5	346	106.3	466	128.5	586	146.5
108	35.4	228	78.1	348	106.7	468	128.8	588	146.8
110	36.4	230	78.7	350	107.2	470	129.1	590	147.1
112	37.3	232	79.2	352	107.6	472	129.4	592	147.3
114	38.2	234	79.8	354	108.0	474	129.8	594	147.6
116	39.1	236	80.3	356	108.4	476	130.1	596	147.9
118	40.0	238	80.9	358	108.8	478	130.4	598	148.2
120	40.9	240	81.4	360	109.2	480	130.7	600	148.4
122	41.7	242	81.9	362	109.6	482	131.1	602	148.7
124	42.6	244	82.5	364	110.0	484	131.4	604	149.0
126	43.4	246	83.0	366	110.4	486	131.7	606	149.2
128	44.3	248	83.5	368	110.8	488	132.0	608	149.5
130	45.1	250	84.1	370	111.2	490	132.3		
132	45.9	252	84.6	372	111.6	492	132.7		
134	46.7	254	85.1	374	112.0	494	133.0		
136	47.5	256	85.6	376	112.3	496	133.3		
138	48.3	258	86.1	378	112.7	498	133.6		
140	49.1	260	86.6	380	113.1	500	133.9		
142	49.9	262	87.1	382	113.5	502	134.2		
144	50.7	264	87.7	384	113.9	504	134.5		
146	51.5	266	88.2	386	114.3	506	134.9		
148	52.2	268	88.7	388	114.7	508	135.2		
150	53.0	270	89.2	390	115.0	510	135.5		
152	53.7	272	89.6	392	115.4	512	135.8		
154	54.5	274	90.1	394	115.8	514	136.1		
156	55.2	276	90.6	396	116.2	516	136.4		
158	55.9	278	91.1	398	116.5	518	136.7		
160	56.6	280	91.6	400	116.9	520	137.0		
162	57.4	282	92.1	402	117.3	522	137.3		
164	58.1	284	92.6	404	117.6	524	137.6		
166	58.8	286	93.0	406	118.0	526	137.9		
168	59.5	288	93.5	408	118.4	528	138.2		
170	60.2	290	94.0	410	118.7	530	138.5		
172	60.8	292	94.5	412	119.1	532	138.8		
174	61.5	294	94.9	414	119.5	534	139.1		
176	62.2	296	95.4	416	119.8	536	139.4		
178	62.9	298	95.8	418	120.2	538	139.7		

## Unit Startup

### Before Powering Unit, Check the Following:

**NOTE:** Remove and discard the compressor hold down shipping bolt located at the front of the compressor mounting bracket.

- **Dip switches are set correctly.**
- **Transformer in air handler switched to 208V if applicable.**
- **High voltage is correct and matches nameplate.**
- Fuses, breakers and wire size correct.
- Low voltage wiring complete.
- Piping completed and water system cleaned and flushed.
- Air is purged from closed loop system.
- Isolation valves are open, water control valves or loop pumps wired.
- Condensate line open and correctly pitched (air handler)
- Hot water generator pump switch is "OFF" unless piping is completed and air has been purged.
- Blower rotates freely in Air Handler
- Blower speed is correct.
- Air filter/cleaner is clean and in position.
- Service/access panels are in place.
- Return air temperature is between 50-80°F heating and 60-95°F cooling.
- Check air coil cleanliness to ensure optimum performance. Clean as needed according to maintenance guidelines. To obtain maximum performance the air coil should be cleaned before startup. A 10% solution of dishwasher detergent and water is recommended for both sides of coil, a thorough water rinse should follow.

## Powering The Controls

### Initial Configuration of the Unit

Before operating the unit, apply power and complete the following Aurora Startup procedure for the controls configuration. An AID Tool is recommended for setup, configuration and troubleshooting, especially with an Aurora 'Advanced' Control. AID Tool version 2.06 or greater is preferred and is required if air handler has AHB board.

#### 1. Configure Aurora Screen

- a. In advanced controls - Confirm AXB is added and communicating.
- b. Air Handler- if air handler has AHB you will need to add AHB and confirm it is communicating.
- c. In advanced controls - If using a communicating thermostat, confirm the communicating thermostat is added and communicating. Set thermostat mode to off.
- d. In advanced controls - Confirm IntelliZone2, if installed, is added and communicating. Set Zoning system to off mode.

#### 2. Aurora Setup Screen

- a. ECM Setup for Heating Airflow (SAH Air Handler with AHB controls only - select "G", low, high and aux blower speeds as appropriate for the unit and electric heat.
- b. Cooling Airflow % - sets the cooling airflow % from heating airflow. Factory setting is -15%.

#### c. AXB Setup

- i. DHW Enable - Ensure air is purged from HW system before enabling (remember the HW switch on the front cabinet)
- ii. DHW Setpoint - 130 °F is the default but can be changed from 100 to 140 °F
- iii. FCV1-GL, FCV2-GL Pump Setup and Modulating Water Valve Setup - Can be setup to a range between 5% and 100%. Defaults are 75% and 100%.
  - From the Main Menu of the AID Tool go to AXB Setup and select "Yes" at the bottom of the screen to Make Changes
  - Set VS Pump Control to MIN
  - The pump(s) or water valve should begin to operate and flow rate is visible on this screen, it may take several seconds for flow to stabilize. Adjust the minimum % until the minimum flow rate is achieved.
  - Go back to Set VS Pump Control and select MAX.
  - The pump(s) or water valve should begin to operate and flow rate is visible on this screen, it may take several seconds for flow to stabilize. Adjust the maximum % until the maximum flow rate is achieved.
  - Press Enter.

#### d. Sensor Kit Setup

- i. Brine Selection - for HE/HR capacity calculation
  - ii. Flow Meter - activates the flow meter
  - iii. Select blower energy (SAH Air Handler AHB Controls Only) - ECM or 5-Speed ECM
  - iv. Activate energy option
  - v. Fan and Aux heat current sensor activation (SAH Air Handler AHB Controls Only)
  - vi. Line Voltage calibration - Voltmeter required to calibrate line voltage during heat or cooling. Refer to Line Voltage Calibration in this manual for more details.
- e. Smart Grid Setup - Select Action option for utility received on-peak signal
  - f. Home Automation 1 & 2 Setup - Select type of sensor for two home automation inputs.

## Configuring the Sensor Kits

### Configuring the Sensor kits

The Aurora Advanced Control allows Refrigeration, Energy, and Performance Monitoring sensor kits. These kits can be factory or field installed. The following description is for field activation of a factory installation of the sensor kits.

## Unit Startup cont.

### Energy Monitoring (Standard Sensor Kit on most 'Advanced' models)

The Energy Monitoring Kit includes two current sensors on the compressor so that compressor power usage can be measured. On the SAH air handler, order control option 'C' which includes an AHB board so that blower and auxiliary heat power can be measured. This will give total power usage of the heat pump. The AID Tool provides configuration detail for the type of blower motor, a line voltage calibration procedure to improve the accuracy, and a power adjustment setting that allows the compressor power to be adjusted to match the unit's line voltage using the provided tables. This information can be displayed on the AID Tool or selected communicating thermostats. The TPCM32U03A\*/04A\* will display instantaneous energy use while the color touchscreen TPCC32U01\* will in addition display a 13 month history in graph form. Ensure the Energy Kit has been enabled by accessing the 'Sensor Kit Setup' in the AID Tool and complete the following:

- a. Select 'Blower Energy' - ECM/5-Speed ECM
- b. Activate 'Energy Option' to activate the sensors on for compressor (2), fan and aux heat current sensor.
- c. Select 'Pump' option of FC1, FC2, VS Pump, VS+26-99, or open loop. This selects the pump watts used in the calculation. Pump watts are not measured but estimated.
- d. Line Voltage Calibration - Voltmeter required to calibrate line voltage during heating or cooling. Refer to Line Voltage Calibration in this manual for more details.
  - i. Turn on Unit in Heating or Cooling .
  - ii. Use multimeter at L1 and L2 to measure line voltage
  - iii. In the Sensor Kit Setup screen adjust the 'Base Voltage' to the nearest value to that is measured
  - iv. Then use the 'Fine Adjust' to select the exact voltage being measured at L1 and L2.
  - v. Exit 'Sensor Setup' Screen
- e. Power Adjustment: Refer to the Single Speed and Dual Capacity Power Adjustment tables in the Aurora 'Advanced' Control section of the literature
  - i. On the Main Menu screen select Setup
  - ii. Once in the Setup menu select the Power Adjustment Factor
  - iii. Power Adjustment - allows you to enter the unit's compressor power setting for high and low speed operation. Refer to the tables and use the voltage that is closest to the unit's line voltage and set the power adjustment accordingly.
- f. Energy monitoring can be read on any of the following components:
  - i. AID Tool - instantaneous information only

- ii. TPCM32U03A/04A Communicating Thermostat (B/W) - instantaneous information only
- iii. TPCC32U01 Color Touchscreen Thermostat - Both Instantaneously and historical (13 months)
- iv. Symphony Web Portal via AWL device connected to Aurora

### Refrigerant Monitoring (optional sensor kit)

The optional Refrigerant Monitoring Kit includes two pressure transducers, and three temperature sensors, heating liquid line, suction temperature and existing cooling liquid line (FP1). These sensors allow the measurement of discharge and suction pressures, suction and liquid line temperatures as well as superheat and subcooling. This information will only be displayed on the AID Tool. Ensure the Refrigerant Monitoring has been setup by accessing the 'Sensor Kit Setup' in the AID Tool and complete the following:

Once sensors are installed for discharge pressure, suction pressure, suction, liquid line cooling and liquid line heating no further setup is required.

- a. Turn on Unit in Heating or Cooling .
- b. Use the AID Tool to view the refrigerant performance in the 'Refrigerant Monitor' screen.
- c. Refrigerant monitoring can be read on any of the following components:
  - i. AID Tool - instantaneous information only
  - ii. Symphony Web Portal via AWL device connected to Aurora

### Performance Monitoring (optional sensor kit)

The optional Performance Monitoring Kit includes two temperature sensors, entering and leaving water and a water flow rate sensor. The SAH Series Air Handler when ordered with control option C will include the LAT (leaving air temperature) sensor. With this kit heat of extraction and rejection will be calculated. This requires configuration using the AID Tool for selection of water or antifreeze. Ensure the Energy Kit has been enabled by accessing the 'Sensor Kit Setup' in the AID Tool and complete the following:

- a. Select 'Brine' - and then choose Water or Antifreeze for the proper factor
- b. Activate 'Flowmeter' to activate the flow sensor select the appropriate 3/4 in. (018-030 models), 1 in. (036-072 models), or none.
- c. Exit Sensor Kit Setup Screen; if the unit is connected to a Variable Speed Flow Center the min/max flow rate must be set.
  - i. Enter the AXB Setup Screen and turn the VS Pump Control On.
  - ii. Then set the VS Pump Min % to achieve at least 2.5 gpm per ton for part load operation.
  - iii. Then set the VS Pump Max % to achieve at least 3.0 gpm per ton for full load operation.

## Unit Startup cont.

---

- d. Turn on Unit in Heating or Cooling .
- e. Use the AID Tool to view the performance in the 'Performance Monitor' screen.
- f. Performance monitoring can be read on any of the following components:
  - i. AID tool - instantaneous information only
  - ii. Symphony Web Portal via AWL device connected to Aurora.

### Startup Steps

**NOTE:** Complete the Equipment Start-Up/Commissioning Check Sheet during this procedure. Refer to thermostat operating instructions and complete the startup procedure. Verify that the compressor shipping bolt has been removed.

1. Initiate a control signal to energize the blower motor. Check blower operation through the AID Tool.
2. Initiate a control signal to place the unit in the cooling mode. Cooling setpoint must be set below room temperature.
3. First stage cooling will energize after a time delay.
4. Be sure that the compressor and water control valve or loop pump(s) are activated.
5. Verify that the water flow rate is correct by measuring the pressure drop through the heat exchanger using the P/T plugs and comparing to unit performance data in catalog.
6. Check the temperature of both the supply and discharge water (see the Unit Operating Parameters tables).
7. Check for an air temperature drop of 15°F to 25°F across the air coil, depending on the fan speed and entering water temperature.
8. Decrease the cooling set point several degrees and verify high-speed blower operation.
9. Adjust the cooling setpoint above the room temperature and verify that the compressor and water valve or loop pumps deactivate.
10. Initiate a control signal to place the unit in the heating mode. Heating set point must be set above room temperature.
11. First stage heating will energize after a time delay.
12. Check the temperature of both the supply and discharge water (see the Unit Operating Parameters tables).
13. Check for an air temperature rise of 12°F to 35°F across the air coil, depending on the fan speed and entering water temperature.
14. If auxiliary electric heaters are installed, increase the heating setpoint until the electric heat banks are sequenced on. All stages of the auxiliary heater should be sequenced on when the thermostat is in the Emergency Heat mode. Check amperage of each element.
15. Adjust the heating setpoint below room temperature and verify that the compressor and water valve or loop pumps deactivate.
16. During all testing, check for excessive vibration, noise or water leaks. Correct or repair as required.
17. Set system to desired normal operating mode and set temperature to maintain desired comfort level.
18. Instruct the owner/operator in the proper operation of the thermostat and system maintenance.

**NOTE:** Be certain to fill out and forward all warranty registration papers.

## Operating Parameters

### Single Speed Models- 022-070 (with SAH Air Handler)

Cooling -- No Desuperheater									
Entering Water Temp °F	Water Flow GPM/Ton	022 thru 048		060 and 070		022 thru 070			
		Suction Pressure PSIG	Discharge Pressure PSIG	Suction Pressure PSIG	Discharge Pressure PSIG	Superheat	Subcooling	Water Temp Rise °F	Air Temp Drop °F DB
30	3.0	95-120	135-155	95-115	135-155	30-40	5-12	5-15	15-22
50	1.5	115-150	170-215	115-130	195-235	12-22	7-14	5-22	18-24
	3.0	110-145	165-205	110-125	190-225	14-30	6-12	8-12	18-24
70	1.5	125-160	245-285	125-160	275-300	8-14	8-12	5-19	18-22
	3.0	115-150	240-280	115-135	265-295	9-16	4-16	5-12	18-22
90	1.5	125-160	320-370	125-160	330-370	8-14	6-13	14-22	18-22
	3.0	120-150	305-355	120-150	325-365	9-16	4-16	8-12	18-22
120	1.5	150-165	485-530	140-160	495-520	8-12	14-18	14-22	18-22
	3.0	145-160	480-520	135-155	490-510	9-14	12-22	8-12	18-22

Heating -- No Desuperheater									
Entering Water Temp °F	Water Flow GPM/Ton	022 thru 048		060 and 070		022 thru 070			
		Suction Pressure PSIG	Discharge Pressure PSIG	Suction Pressure PSIG	Discharge Pressure PSIG	Superheat	Subcooling	Water Temp Drop °F	Air Temp Rise °F DB
20	3.0	60-75	255-285	60-75	280-300	6-14	2-10	12-22	2-7
30	1.5	65-85	290-310	65-85	330-360	7-13	2-21	7-10	18-24
	3.0	70-90	265-330	70-90	335-365	6-12	2-21	3-7	22-26
50	1.5	95-120	320-345	95-120	395-430	6-14	2-21	4-11	21-34
	3.0	100-125	280-365	100-125	375-405	6-14	4-22	4-11	24-33
70	1.5	135-155	315-380	140-170	400-440	8-16	10-20	8-14	26-46
	3.0	135-156	315-395	140-170	405-445	8-16	10-20	3-10	25-48
90	1.5	165-190	390-410	165-180	395-410	10-20	8-15	7-14	26-46
	3.0	160-185	385-420	160-175	390-415	10-20	5-15	5-11	25-48

3/22/2017

Note: Cooling performance based on entering air temperatures of 80° F DB, 67° F WB.  
 Heating performance based on entering air temperature of 70° F DB.

## Operating Parameters cont.

### Unit Operating Parameters 026 thru 072 (with SAH Air Handler) First Stage Operation

Cooling -- No Desuperheater									
Entering Water Temp °F	Water Flow GPM/Ton	026 thru 064		072		026 thru 072			
		Suction Pressure PSIG	Discharge Pressure PSIG	Suction Pressure PSIG	Discharge Pressure PSIG	Superheat	Subcooling	Water Temp Rise °F	Air Temp Drop °F DB
30	3.0	105-120	125-140	90-105	135-145	25-40	4-15	7-11	15-24
50	1.5	130-150	170-210	130-150	180-210	8-17	7-14	7-20	18-24
	3.0	128-153	175-195	125-140	185-205	10-20	3-10	9-14	18-25
70	1.5	130-150	235-270	135-150	240-280	6-16	4-16	9-18	18-25
	3.0	130-155	240-265	125-145	245-270	6-18	5-11	5-10	18-24
90	1.5	133-148	310-245	130-155	300-365	7-16	6-18	4-11	19-25
	3.0	138-155	320-350	130-165	305-350	7-18	7-14	5-10	17-22
120	1.5	143-158	460-485	135-145	475-505	7-16	6-18	4-11	19-25
	3.0	145-165	470-495	145-155	485-500	6-15	8-15	5-12	17-22

Heating -- No Desuperheater									
Entering Water Temp °F	Water Flow GPM/Ton	026 thru 064		072		026 thru 072			
		Suction Pressure PSIG	Discharge Pressure PSIG	Suction Pressure PSIG	Discharge Pressure PSIG	Superheat	Subcooling	Water Temp Drop °F	Air Temp Rise °F DB
20	3.0	60-75	255-275	55-65	275-290	8-16	4-5	2-8	15-24
30	1.5	78-100	275-325	85-105	315-345	6-11	4-16	2-8	20-29
	3.0	78-110	275-320	90-120	305-335	6-11	4-16	3-7	20-32
50	1.5	105-120	305-350	100-130	340-400	5-12	4-16	5-12	24-32
	3.0	110-125	300-360	110-125	345-395	9-15	2-14	4-9	20-34
70	1.5	140-155	305-355	130-165	370-430	5-12	2-14	8-12	24-39
	3.0	145-160	330-400	140-160	375-425	7-17	7-15	4-10	24-39
90	1.5	170-195	340-385	155-175	430-465	7-16	6-18	4-11	20-34
	3.0	175-200	350-390	160-180	440-470	7-18	7-14	5-10	24-38

### Second Stage Operation

Cooling -- No Desuperheater									
Entering Water Temp °F	Water Flow GPM/Ton	026 thru 064		072		026 thru 072			
		Suction Pressure PSIG	Discharge Pressure PSIG	Suction Pressure PSIG	Discharge Pressure PSIG	Superheat	Subcooling	Water Temp Rise °F	Air Temp Drop °F DB
30	3.0	90-115	135-150	95-115	125-145	25-40	4-15	7-11	15-24
50	1.5	120-140	175-235	105-150	190-220	7-17	6-14	7-16	19-26
	3.0	115-140	170-220	110-130	185-210	7-20	4-11	7-12	20-24
70	1.5	121-136	245-280	105-150	240-290	9-15	6-18	7-12	19-25
	3.0	120-145	245-275	110-140	245-280	10-16	7-16	8-12	18-24
90	1.5	122-140	310-360	115-140	325-385	8-14	6-18	10-16	18-24
	3.0	135-150	310-365	120-135	330-365	8-14	7-15	6-12	17-23
120	1.5	135-155	470-515	130-155	485-520	7-16	6-18	4-11	19-25
	3.0	140-160	475-520	135-150	490-515	6-15	8-15	5-12	17-22

Heating -- No Desuperheater									
Entering Water Temp °F	Water Flow GPM/Ton	026 thru 064		072		026 thru 072			
		Suction Pressure PSIG	Discharge Pressure PSIG	Suction Pressure PSIG	Discharge Pressure PSIG	Superheat	Subcooling	Water Temp Drop °F	Air Temp Rise °F DB
20	3.0	45-65	245-280	45-55	265-275	8-16	4-5	2-8	15-24
30	1.5	72-89	295-340	70-100	320-370	7-18	10-20	4-13	18-24
	3.0	73-87	285-320	75-90	315-365	7-18	10-20	4-16	18-27
50	1.5	100-120	320-355	95-130	375-430	6-14	6-18	4-10	23-34
	3.0	105-120	315-355	100-125	370-420	6-14	6-18	4-9	20-37
70	1.5	142-158	340-370	130-165	400-470	6-12	4-15	6-15	28-38
	3.0	138-152	345-385	135-160	405-465	7-14	4-15	6-12	24-42
90	1.5	162-205	365-425	170-200	440-500	7-16	6-18	4-11	25-36
	3.0	160-195	370-430	175-195	450-490	7-18	7-14	5-10	28-40

## Antifreeze Corrections

Catalog performance can be corrected for antifreeze use. Please use the following table and note the example given.

Antifreeze Type	Antifreeze % by wt	Heating	Cooling	Pressure Drop
EWT - °F [°C]		30 [-1.1]	90 [32.2]	30 [-1.1]
Water	0	1.000	1.000	1.000
Ethylene Glycol	10	0.973	0.991	1.075
	20	0.943	0.979	1.163
	30	0.917	0.965	1.225
	40	0.890	0.955	1.324
	50	0.865	0.943	1.419
Propylene Glycol	10	0.958	0.981	1.130
	20	0.913	0.969	1.270
	30	0.854	0.950	1.433
	40	0.813	0.937	1.614
	50	0.770	0.922	1.816
Ethanol	10	0.927	0.991	1.242
	20	0.887	0.972	1.343
	30	0.856	0.947	1.383
	40	0.815	0.930	1.523
	50	0.779	0.911	1.639
Methanol	10	0.957	0.986	1.127
	20	0.924	0.970	1.197
	30	0.895	0.951	1.235
	40	0.863	0.936	1.323
	50	0.833	0.920	1.399



**WARNING:** Gray area represents antifreeze concentrations greater than 35% by weight and should be avoided due to the extreme performance penalty they represent.

### Antifreeze Correction Example

Antifreeze solution is Propylene Glycol 20% by weight. Determine the corrected heating and cooling performance at 30°F and 90°F respectively as well as pressure drop at 30°F for an Indoor Split \*022.

The corrected cooling capacity at 90°F would be: 18,400 MBtu/h x 0.969 = 17,830 MBtu/h

The corrected heating capacity at 30°F would be: 14,900 MBtu/h x 0.913 = 13,604 MBtu/h

The corrected pressure drop at 30°F and 6 gpm would be: 7.1 feet of head x 1.270 = 9.01 feet of head

## Correction Factor Tables

### Air Flow Corrections (Dual Capacity Part Load)

Airflow		Cooling				Heating		
cfm Per Ton of Clg	% of Nominal	Total Cap	Sens Cap	Power	Heat of Rej	Htg Cap	Power	Heat of Ext
240	60	0.922	0.778	0.956	0.924	0.943	1.239	0.879
275	69	0.944	0.830	0.962	0.944	0.958	1.161	0.914
300	75	0.957	0.866	0.968	0.958	0.968	1.115	0.937
325	81	0.970	0.900	0.974	0.970	0.977	1.075	0.956
350	88	0.982	0.933	0.981	0.980	0.985	1.042	0.972
375	94	0.991	0.968	0.991	0.991	0.993	1.018	0.988
<b>400</b>	<b>100</b>	<b>1.000</b>	<b>1.000</b>	<b>1.000</b>	<b>1.000</b>	<b>1.000</b>	<b>1.000</b>	<b>1.000</b>
425	106	1.007	1.033	1.011	1.008	1.007	0.990	1.010
450	113	1.013	1.065	1.023	1.015	1.012	0.987	1.018
475	119	1.017	1.099	1.037	1.022	1.018	0.984	1.025
500	125	1.020	1.132	1.052	1.027	1.022	0.982	1.031
520	130	1.022	1.159	1.064	1.030	1.025	0.979	1.034

1/5/17

### Air Flow Corrections (Dual Capacity Full Load and Single Speed)

Airflow		Cooling				Heating		
cfm Per Ton of Clg	% of Nominal	Total Cap	Sens Cap	Power	Heat of Rej	Htg Cap	Power	Heat of Ext
240	60	0.922	0.786	0.910	0.920	0.943	1.150	0.893
275	69	0.944	0.827	0.924	0.940	0.958	1.105	0.922
300	75	0.959	0.860	0.937	0.955	0.968	1.078	0.942
325	81	0.971	0.894	0.950	0.967	0.977	1.053	0.959
350	88	0.982	0.929	0.964	0.978	0.985	1.031	0.973
375	94	0.992	0.965	0.982	0.990	0.993	1.014	0.988
<b>400</b>	<b>100</b>	<b>1.000</b>	<b>1.000</b>	<b>1.000</b>	<b>1.000</b>	<b>1.000</b>	<b>1.000</b>	<b>1.000</b>
425	106	1.007	1.034	1.020	1.010	1.007	0.990	1.011
450	113	1.012	1.065	1.042	1.018	1.013	0.983	1.020
475	119	1.017	1.093	1.066	1.026	1.018	0.980	1.028
500	125	1.019	1.117	1.092	1.033	1.023	0.978	1.034
520	130	1.020	1.132	1.113	1.038	1.026	0.975	1.038

1/5/17

### Cooling Capacity Corrections

Entering Air WB °F	Total Clg Cap	Sensible Cooling Capacity Multipliers - Entering DB °F										Power Input	Heat of Rejection
		60	65	70	75	80	80.6	85	90	95	100		
55	0.898	0.723	0.866	1.048	1.185	*	*	*	*	*	*	0.985	0.913
60	0.912		0.632	0.880	1.078	1.244	1.260	*	*	*	*	0.994	0.927
63	0.945			0.768	0.960	1.150	1.175	*	*	*	*	0.996	0.954
65	0.976			0.694	0.881	1.079	1.085	1.270	*	*	*	0.997	0.972
66.2	0.983			0.655	0.842	1.040	1.060	1.232	*	*	*	0.999	0.986
<b>67</b>	<b>1.000</b>			0.616	0.806	<b>1.000</b>	1.023	1.193	1.330	1.480	*	<b>1.000</b>	<b>1.000</b>
70	1.053				0.693	0.879	0.900	1.075	1.205	1.404	*	1.003	1.044
75	1.168					0.687	0.715	0.875	1.040	1.261	1.476	1.007	1.141

NOTE: \* Sensible capacity equals total capacity at conditions shown.

1/5/17

### Heating Capacity Corrections

Ent Air DB °F	Heating Corrections		
	Htg Cap	Power	Heat of Ext
45	1.062	0.739	1.158
50	1.050	0.790	1.130
55	1.037	0.842	1.096
60	1.025	0.893	1.064
65	1.012	0.945	1.030
68	1.005	0.976	1.012
<b>70</b>	<b>1.000</b>	<b>1.000</b>	<b>1.000</b>
75	0.987	1.048	0.970
80	0.975	1.099	0.930

1/5/17



# Pressure Drop

## Single Speed

Model	GPM	Pressure Drop (psi)				
		30°F	50°F	70°F	90°F	110°F
<b>022</b>	3	1.0	0.1	0.9	0.8	0.8
	4.5	2.1	1.9	1.8	1.6	1.5
	6	3.2	2.9	2.7	2.4	2.3
	8	5.1	4.6	3.9	3.7	3.5
<b>030</b>	4	1.6	1.5	1.4	1.3	1.2
	6	3.2	3.0	2.8	2.6	2.4
	8	4.7	4.4	4.1	3.8	3.5
	10	7.0	6.5	5.6	5.5	5.1
<b>036</b>	5	1.6	1.5	1.4	1.3	1.2
	7	2.8	2.7	2.5	2.3	2.2
	9	4.2	3.9	3.7	3.4	3.2
	12	6.7	6.4	6.2	5.6	5.4
<b>042</b>	5	1.5	1.4	1.3	1.2	1.1
	8	3.5	3.3	3.1	2.9	2.7
	11	5.6	5.2	4.9	4.6	4.2
	14	8.1	7.9	7.6	7.3	7.0
<b>048</b>	6	1.3	1.2	1.1	1.0	1.0
	9	2.7	2.6	2.4	2.2	2.1
	12	4.1	3.9	3.6	3.4	3.1
	16	6.9	6.7	6.4	6.2	5.9
<b>060</b>	9	2.1	2.0	1.9	1.8	1.6
	12	3.9	3.6	3.4	3.2	2.9
	15	5.7	5.3	5.0	4.6	4.3
	20	9.5	8.9	8.3	7.8	7.2
<b>070</b>	12	3.3	3.1	2.9	2.7	2.5
	15	5.0	4.7	4.4	4.1	3.8
	18	6.7	6.3	5.9	5.5	5.1
	24	9.7	9.5	9.2	8.4	7.9

1/4/16

## Dual Capacity

Model	GPM	Pressure Drop (psi)				
		30°F	50°F	70°F	90°F	110°F
<b>026 full load</b>	4	1.4	1.3	1.2	1.1	1.0
	6	3.3	3.1	2.9	2.7	2.5
	8	5.1	4.8	4.5	4.2	3.9
	10	7.2	6.9	6.6	6.3	6.0
<b>026 part load</b>	3	1.0	0.9	0.9	0.8	0.7
	5	2.5	2.3	2.2	2.0	1.9
	7	3.9	3.6	3.4	3.2	2.9
	9	6.2	5.9	5.7	5.5	5.2
<b>038 full load</b>	5	1.2	1.2	1.1	1.0	1.0
	7	2.5	2.3	2.2	2.0	1.9
	9	3.6	3.4	3.2	3.0	2.8
	11	5.2	5.0	4.8	4.6	4.4
<b>038 part load</b>	4	0.9	0.9	0.8	0.8	0.7
	6	2.0	1.9	1.8	1.7	1.6
	8	2.9	2.8	2.7	2.5	2.3
	10	4.1	4.0	3.8	3.6	3.4
<b>049 full load</b>	6	1.3	1.2	1.1	1.1	1.0
	9	2.7	2.6	2.4	2.2	2.1
	12	4.2	3.9	3.7	3.3	3.2
	15	6.0	5.7	5.5	5.2	5.0
<b>049 part load</b>	5	0.9	0.8	0.8	0.7	0.7
	8	2.2	2.0	1.9	1.7	1.6
	11	3.5	3.3	3.1	2.8	2.7
	14	5.1	4.9	4.7	4.4	4.2
<b>064 full load</b>	8	1.8	1.7	1.6	1.5	1.4
	12	4.1	3.8	3.6	3.4	3.1
	16	6.5	6.1	5.7	5.3	4.9
	20	9.7	9.2	8.6	8.2	7.6
<b>064 part load</b>	6	1.1	1.0	0.9	0.9	0.8
	10	3.3	3.1	2.9	2.7	2.5
	14	5.6	5.3	4.9	4.6	4.3
	18	8.4	8.1	7.7	7.4	7.1
<b>072 full load</b>	12	3.3	3.1	2.9	2.7	2.5
	15	5.0	4.7	4.4	4.1	3.8
	18	6.8	6.4	6.0	5.5	5.1
	21	8.4	8.0	7.6	7.1	6.8
<b>072 part load</b>	10	2.4	2.3	2.1	2.0	1.8
	13	4.0	3.7	3.5	3.3	3.0
	16	5.6	5.2	4.9	4.6	4.2
	19	7.1	6.8	6.5	6.2	5.9

1/4/17

## Refrigerant Circuit Guideline

Symptom	Head Pressure	Suction Pressure	Compressor Amp Draw	Superheat	Subcooling	Air Temp. Differential	Water Temp. Differential
Under Charged System (Possible Leak)	Low	Low	Low	High	Low	Low	Low
Over Charged System	High	High	High	Normal	High	Normal/Low	Normal
Low Air Flow Heating	High	High	High	High/Normal	Low	High	Low
Low Air Flow Cooling	Low	Low	Low	Low/Normal	High	High	Low
Low Water Flow Heating	Low/Normal	Low/Normal	Low	Low	High	Low	High
Low Water Flow Cooling	High	High	High	High	Low	Low	High
High Air Flow Heating	Low	Low	Low	Low	High	Low	Low
High Air Flow Cooling	Low	High	Normal	High	Low	Low	Normal
High Water Flow Heating	Normal	Low	Normal	High	Normal	Normal	Low
High Water Flow Cooling	Low	Low	Low	Low	High	Normal	Low
Low Indoor Air Temperature Heating	Low	Low	Low	Normal	High	Normal	Normal/High
Low Indoor Air Temperature Cooling	Low	Low	Low	Normal/Low	High	Low	Low
High Indoor Air Temperature Heating	High	High	High	Normal/High	Normal/Low	Low	Normal
High Indoor Air Temperature Cooling	High	High	High	High	Low	Low	High
Restricted TXV (Check Service Advisory)	High	Low	Normal/Low	High	High	Low	Low
Insufficient Compressor (Possible Bad Valves)	Low	High	Low	High	Normal/High	Low	Low
TXV - Bulb Loss of Charge	Low	Low	Low	High	High	Low	Low
Scaled Coaxial Heat Exchanger Heating	Low	Low	Low	Normal/Low	High	Low	Low
Scaled Coaxial Heat Exchanger Cooling	High	High	High	Normal/Low	Low	Low	Low
Restricted Filter Drier	Check temperature difference (delta T) across filter drier.						

7/6/10

## Thermistor Resistance

Thermistor Temperature (°F)	Resistance in Ohms
78.5	9230 - 10007
77.5	9460 - 10032
76.5	9690 - 10580
75.5	9930 - 10840
33.5	30490 - 32080
32.5	31370 - 33010
31.5	32270 - 33690
30.5	33190 - 34940
1.5	79110 - 83750
0.5	81860 - 86460
0.0	82960 - 87860

## Compressor Resistance

Model	Compressor Model No.	208-230/60/1	
		Run	Start
<b>022</b>	ZP16K5E-PFV	1.39 - 1.53	2.15 - 2.30
<b>030</b>	ZP21K5E-PFV	1.21 - 1.39	1.53 - 1.75
<b>036</b>	ZP25K5E-PFV	0.95 - 1.09	1.81 - 2.09
<b>042</b>	ZP31K5E-PFV	0.83 - 0.95	1.54 - 1.78
<b>048</b>	ZP38K5E-PFV	0.51 - 0.59	1.13 - 1.31
<b>060</b>	ZP51K5E-PFV	0.42 - 0.48	0.73 - 0.85
<b>070</b>	ZP57K5E-PFV	0.33 - 0.39	0.90 - 1.04
<b>026</b>	ZPS20K5E-PFV	1.21 - 1.39	1.52 - 1.75
<b>038</b>	ZPS30K5E-PFV	0.81 - 0.94	1.41 - 1.63
<b>049</b>	ZPS40K5E-PFV	0.48 - 0.55	1.72 - 1.99
<b>064</b>	ZPS51K5E-PFV	0.36 - 0.42	1.51 - 1.74
<b>072</b>	ZPS60K5E-PFV	0.31 - 0.36	1.72 - 1.98

2/7/12

## Heat of Extraction/Rejection Data - Single Speed Units

Model	GPM	Heat of Extraction (kBtuh)				Heat of Rejection (kBtuh)				
		30°F	50°F	70°F	90°F	30°F	50°F	70°F	90°F	110°F
022	3.0		13.5	18.1	22.3		23.8	23.4	21.9	
	4.5	9.5	14.1	19.2	23.6	21.5	23.9	23.5	22.1	20.4
	6.0	10.8	14.9	19.5	23.8	21.8	24.2	23.7	22.4	20.5
030	4.0		18.3	24.3	30.0		29.1	30.7	28.0	
	6.0	13.2	19.1	25.6	31.2	24.6	29.8	30.8	28.1	27.2
	8.0	14.4	20.2	26.3	32.0	24.8	30.2	31.2	28.3	27.4
036	5.0		22.4	29.3	35.8		37.3	38.1	35.5	
	7.0	16.0	23.4	30.9	37.8	31.4	37.5	38.2	35.6	33.9
	9.0	17.6	24.7	31.7	37.9	31.6	38.0	38.7	36.1	34.2
042	5.0		26.3	34.4	42.4		48.5	47.0	45.5	
	8.0	19.1	27.5	36.3	45.2	39.6	48.7	47.2	45.6	44.2
	11.0	21.0	29.0	37.3	45.4	39.8	49.3	47.7	45.9	44.4
048	6.0		31.9	40.3	48.2		55.8	54.4	50.8	
	9.0	25.0	34.1	42.1	48.9	48.0	56.2	54.7	51.0	45.6
	12.0	25.3	34.7	43.3	50.8	48.2	56.5	55.0	51.5	45.7
060	9.0		40.6	50.7	60.0		71.7	70.0	66.1	
	12.0	32.6	43.5	52.9	60.8	62.4	72.1	70.3	66.4	63.9
	15.0	32.9	44.2	54.5	63.3	62.6	72.6	70.7	68.2	64.1
070	12.0		46.0	58.3	68.3		78.6	79.1	71.4	
	15.0	36.8	49.3	60.9	69.2	67.2	79.1	79.5	71.7	69.2
	18.0	37.2	50.2	62.7	72.1	67.6	79.5	79.9	74.2	69.4

Note: operation not recommended in shaded areas.

1/4/2017

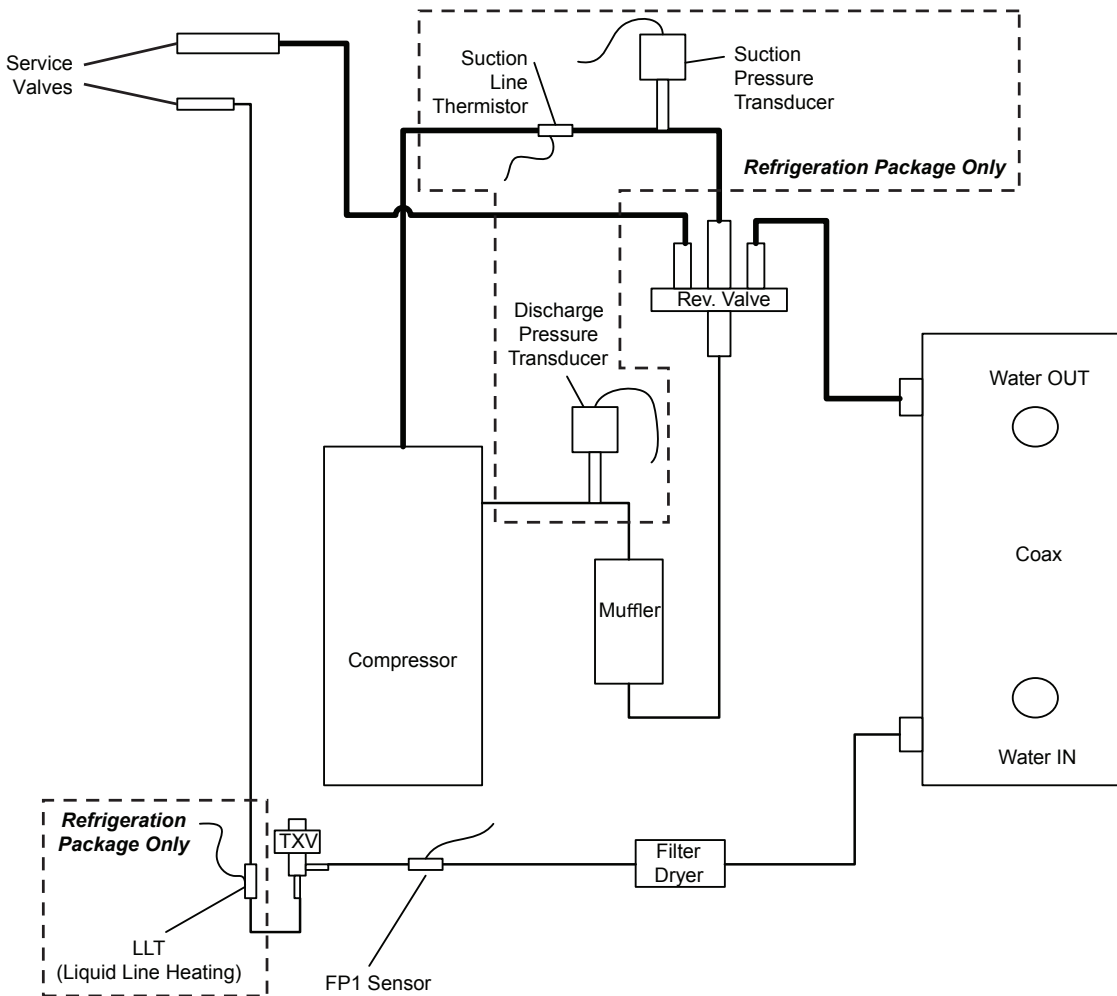
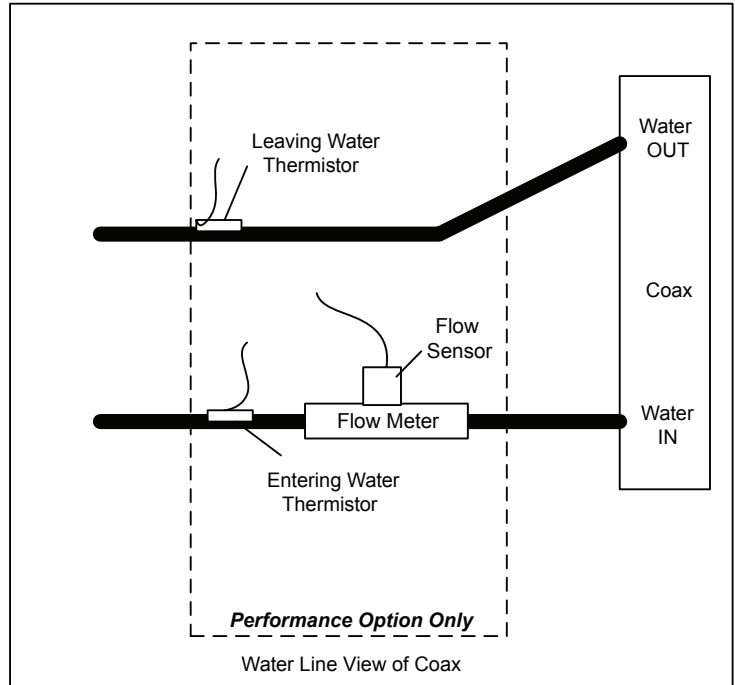
## Heat of Extraction/Rejection Data - Dual Capacity

Model		GPM	Heat of Extraction (kBtuh)				Heat of Rejection (kBtuh)				
			30°F	50°F	70°F	90°F	30°F	50°F	70°F	90°F	110°F
026	Part Load	3.0		12.6	16.8	20.9		22.2	21.9	19.9	
		5.0	8.7	13.2	17.7	22.2	19.3	22.3	22.0	20.1	19.2
		7.0	9.5	13.9	18.2	22.3	19.4	22.7	22.3	20.2	19.4
	Full Load	4.0		17.2	21.3	23.3		29.9	29.5	27.4	
		6.0	13.1	17.9	22.5	27.0	24.6	30.2	29.9	27.8	27.3
		8.0	13.3	18.4	23.2	29.3	26.5	30.4	30.0	27.9	27.6
038	Part Load	4.0		18.3	24.3	29.9		31.9	32.0	29.7	
		6.0	12.7	19.1	25.7	31.8	26.3	32.1	32.1	29.8	28.5
		8.0	14.0	20.2	26.4	32.0	26.6	32.5	32.5	30.0	28.7
	Full Load	5.0		26.1	31.2	36.8		41.0	43.4	42.1	
		7.0	20.4	27.1	32.9	39.2	35.2	41.4	44.0	42.9	39.1
		9.0	20.8	27.9	33.9	40.7	35.4	41.6	44.2	43.3	39.2
049	Part Load	5.0		26.1	30.1	35.4		45.3	41.8	38.3	
		8.0	17.3	28.5	33.2	39.2	38.4	45.4	42.0	38.5	35.3
		11.0	18.2	29.9	35.0	41.8	38.5	45.6	42.3	39.5	36.1
	Full Load	6.0		32.3	39.4	45.6		58.0	57.2	53.3	
		9.0	26.4	35.3	43.6	50.7	48.5	58.6	57.8	53.6	49.6
		12.0	27.6	37.0	46.1	54.1	48.6	58.8	57.9	54.1	50.9
064	Part Load	6.0		30.1	39.1	46.5		56.4	54.3	50.3	
		10.0	20.4	30.5	41.1	50.1	48.5	56.7	54.4	50.5	47.9
		14.0	21.7	31.7	42.0	50.4	48.6	56.9	54.5	50.7	48.2
	Full Load	8.0		40.8	51.3	59.5		74.0	70.8	69.4	
		12.0	32.7	43.7	53.5	60.4	64.7	74.5	71.2	69.8	65.7
		16.0	32.9	44.5	55.1	62.8	64.8	75.0	71.6	71.8	65.9
072	Part Load	10.0		36.1	46.0	54.2		64.6	62.3	56.7	
		13.0	25.7	36.7	48.1	58.5	56.6	65.5	62.6	57.7	56.2
		16.0	28.4	38.1	49.0	58.8	56.7	66.0	62.8	59.5	56.4
	Full Load	12.0		47.4	63.5	71.4		83.2	77.7	74.4	
		15.0	38.3	50.7	66.2	72.5	72.5	83.7	78.0	74.6	71.4
		18.0	39.2	51.7	68.1	75.5	72.6	84.2	78.5	74.8	71.7

Note: operation not recommended in shaded areas.

1/4/2017

# Troubleshooting



## Troubleshooting cont.

---

### Aurora Control System

**NOTE:** Refer to the Aurora Base Control Application and Troubleshooting Guide and the Instruction Guide: Aurora Interface and Diagnostics (AID) Tool for additional information.

To check the unit control board for proper operation:

1. Disconnect thermostat wires at the control board.
2. Jumper the desired test input (Y1, Y2, W, O or G) to the R terminal to simulate a thermostat signal.
3. If control functions properly:
  - Check for thermostat and field control wiring (use the diagnostic inputs mode).
4. If control responds improperly:
  - Ensure that component being controlled is functioning (compressor, blower, reversing valve, etc.).
  - Ensure that wiring from control to the component is correct.
  - Refer to the Aurora Base Control Application and Troubleshooting Guide and the Instruction Guide: Aurora Interface and Diagnostics (AID) Tool for additional information.

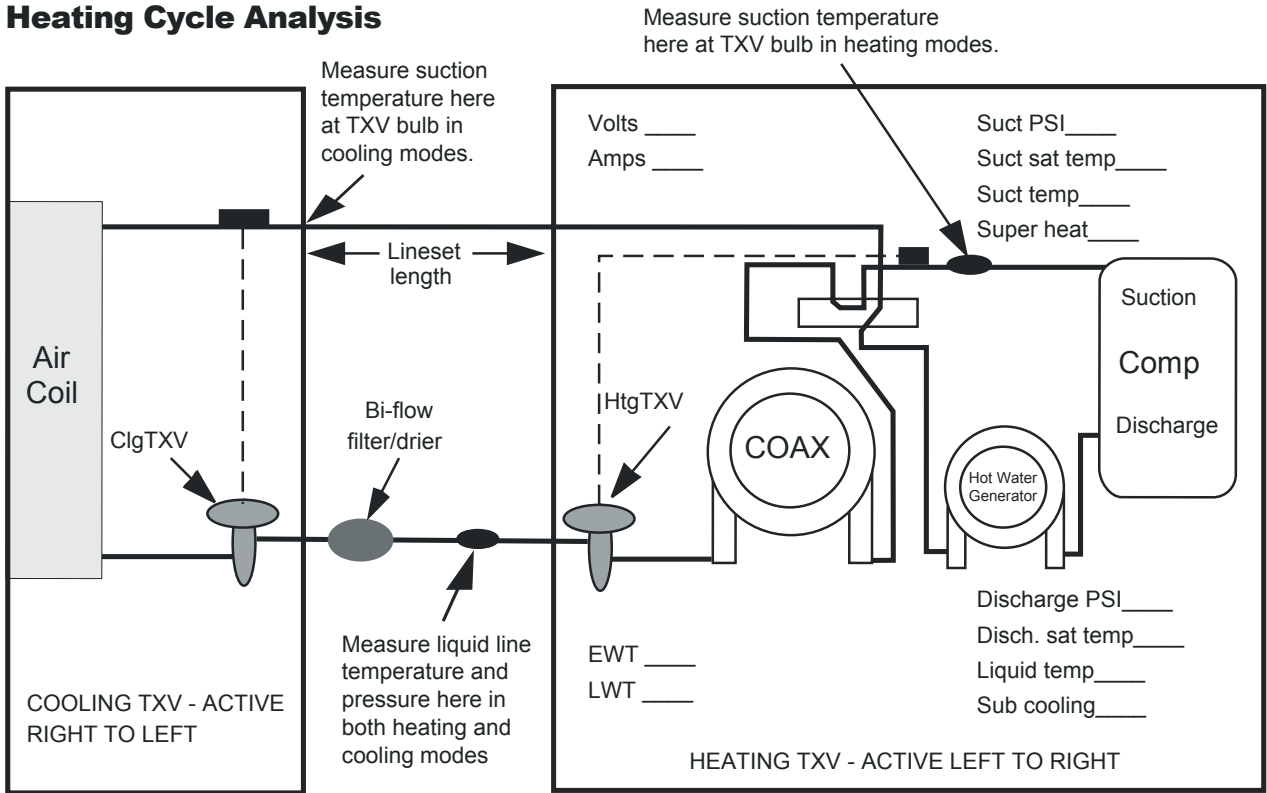
### Refrigerant Systems

To maintain sealed circuit integrity, do not install service gauges unless unit operation appears abnormal. Compare the change in temperature on the air side as well as the water side to the Unit Operating Parameters tables. If the unit's performance is not within the ranges listed, and the airflow and water flow are known to be correct, gauges should then be installed and superheat and subcooling numbers calculated. If superheat and subcooling are outside recommended ranges, an adjustment to the refrigerant charge may be necessary.

**NOTE:** Refrigerant tests must be made with hot water generator turned "OFF". Verify that air and water flow rates are at proper levels before servicing the refrigerant circuit.

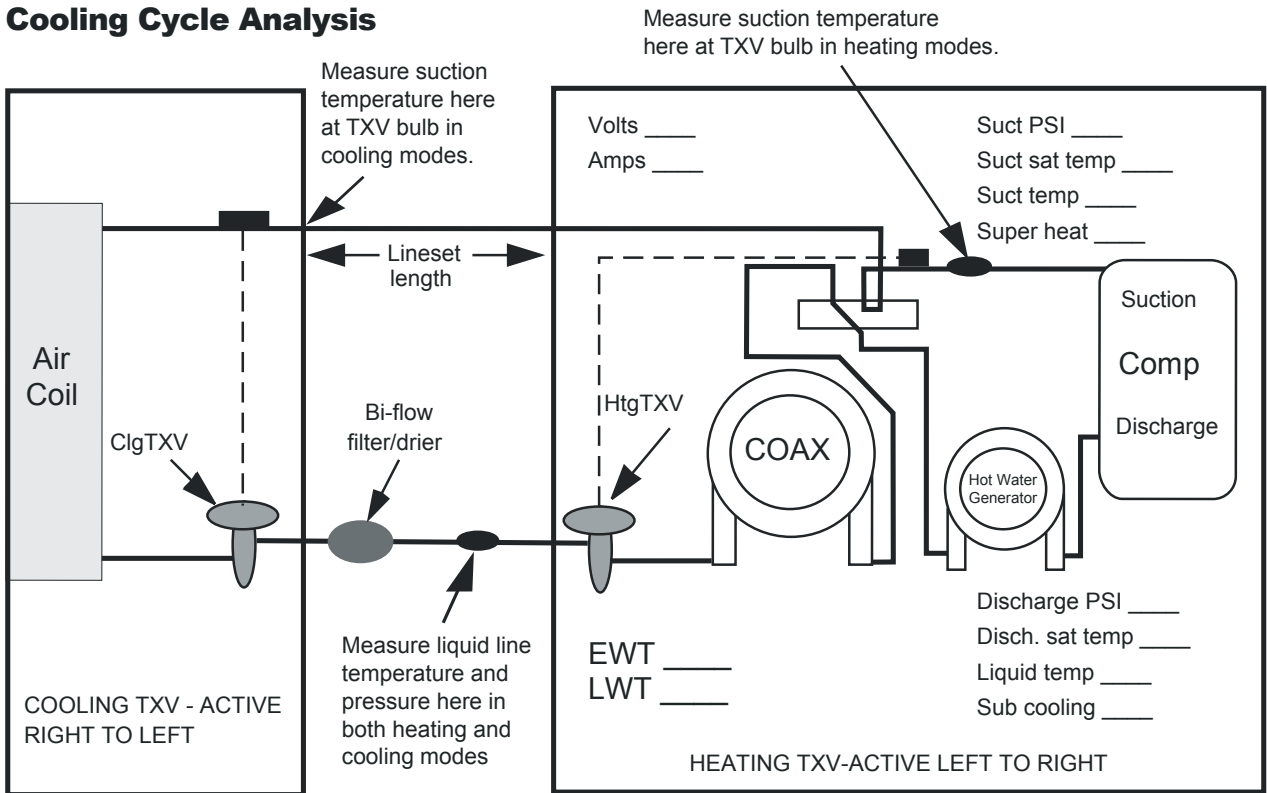
# Unit Startup/Troubleshooting

## Heating Cycle Analysis



**Heat of Extraction/Rejection = GPM x 500 (485 for water/antifreeze) x ΔT**  
**Note: DO NOT hook up pressure gauges unless there appears to be a performance problem.**

## Cooling Cycle Analysis





# Troubleshooting cont.

## Single Speed/Dual Capacity Startup/Troubleshooting Form

### 1. Job Information

Model # \_\_\_\_\_ Job Name: \_\_\_\_\_ Loop: Open / Closed  
 Serial # \_\_\_\_\_ Install Date: \_\_\_\_\_ Hot Water Generator: Y / N

### 2. Flow Rate in gpm

	SOURCE COAX		LOAD COAX (Water-to-Water)	
	HEATING	COOLING	HEATING	COOLING
WATER IN Pressure:	a. _____ psi	a. _____ psi	a. _____ psi	a. _____ psi
WATER OUT Pressure:	b. _____ psi	b. _____ psi	b. _____ psi	b. _____ psi
Pressure Drop: a - b	c. _____ psi	c. _____ psi	c. _____ psi	c. _____ psi
Look up flow rate in table:	d. _____ gpm	d. _____ gpm	d. _____ gpm	d. _____ gpm

### 3. Temp. Rise/Drop Across Air Coil<sup>1</sup>

	HEATING	COOLING
SUPPLY AIR Temperature:	e. _____ °F	e. _____ °F
RETURN AIR Temperature:	f. _____ °F	f. _____ °F
Temperature Difference:	g. _____ °F	g. _____ °F

### 4. Temp. Rise/Drop Across Coaxial Heat Exchanger

	SOURCE COAX		LOAD COAX (Water-to-Water)	
	HEATING	COOLING	HEATING	COOLING
WATER IN Temperature:	h. _____ °F	h. _____ °F	h. _____ °F	h. _____ °F
WATER OUT Temperature:	i. _____ °F	i. _____ °F	i. _____ °F	i. _____ °F
Temperature Difference:	j. _____ °F	j. _____ °F	j. _____ °F	j. _____ °F

### 5. Heat of Rejection (HR)/Heat of Extraction (HE)

Brine Factor<sup>2</sup>: k. \_\_\_\_\_

HR/HE =  $d \times g \times k$

	HEATING	COOLING
	l. _____ Btu/h	l. _____ Btu/h

### STEPS 6-9 NEED ONLY BE COMPLETED IF A PROBLEM IS SUSPECTED.

### 6. Watts

	ENERGY MONITOR	
	HEATING	COOLING
Volts:	m. _____ Volts	m. _____ Volts
Total Amps (Comp. + Blower) <sup>3</sup> :	n. _____ Amps	n. _____ Amps
Watts = $m \times n \times 0.85$ :	o. _____ Watts	o. _____ Watts

### 7. Capacity

	HEATING	COOLING
Cooling Capacity = $l - (o \times 3.413)$ :	p. _____ Btu/h	p. _____ Btu/h
Heating Capacity = $l + (o \times 3.413)$ :		

### 8. Efficiency

	HEATING	COOLING
Cooling EER = $p / o$ :	q. _____ Btu/h	q. _____ Btu/h
Heating COP = $p / (o \times 3.413)$ :		

### 9. Superheat (S.H.)/Subcooling (S.C.)

	HEATING	COOLING
Suction Pressure:	r. _____ psi	r. _____ psi
Suction Saturation Temperature:	s. _____ °F	s. _____ °F
Suction Line Temperature:	t. _____ °F	t. _____ °F
S.H. = $t - s$ :	u. _____ °F	u. _____ °F
Head Pressure:	v. _____ psi	v. _____ psi
High Pressure Saturation Temp:	w. _____ °F	w. _____ °F
Liquid Line Temperature <sup>4</sup> :	x. _____ °F	x. _____ °F
S.C. = $w - x$ :	y. _____ °F	y. _____ °F

Software Version
ABC: _____
AXB: _____
IZZ: _____
T'STAT: _____

**NOTES:** <sup>1</sup> Steps 3-9 should be conducted with the hot water generator disconnected.

<sup>2</sup> Use 500 for pure water, 485 for methanol or Environol™. (This constant is derived by multiplying the weight of one gallon of water (8.34) times the minutes in one hour (60) times the specific heat of the fluid. Water has a specific heat of 1.0.

<sup>3</sup> If there is only one source of power for the compressor and blower, amp draw can be measured at the source wiring connection.

<sup>4</sup> Liquid line is between the coax and the expansion device in the cooling mode; between the air coil and the expansion device in the heating mode.

## Preventive Maintenance

---

### Water Coil Maintenance

1. Keep all air out of the water. An open loop system should be checked to ensure that the well head is not allowing air to infiltrate the water line. Lines should always be airtight.
2. Keep the system under pressure at all times. It is recommended in open loop systems that the water control valve be placed in the discharge line to prevent loss of pressure during off cycles. Closed loop systems must have positive static pressure.

**NOTE:** On open loop systems, if the installation is in an area with a known high mineral content (125 PPM or greater) in the water, it is best to establish with the owner a periodic maintenance schedule so the coil can be checked regularly. Should periodic coil cleaning be necessary, use standard coil cleaning procedures which are compatible with either the cupronickel or copper water lines. Generally, the more water flowing through the unit the less chance for scaling.

### Other Maintenance

#### Filters

Filters must be clean to obtain maximum performance. They should be inspected monthly under normal operating conditions and be replaced when necessary. Units should never be operated without a filter.

#### Condensate Drain

In areas where airborne bacteria produce a slime in the drain pan, it may be necessary to treat chemically to minimize the problem. The condensate drain can pick up lint and dirt, especially with dirty filters. Inspect twice a year to avoid the possibility of overflow.

#### Blower Motors

ECM blower motors are equipped with sealed ball bearings and require no periodic oiling.

#### Hot Water Generator Coil

See Water Coil Maintenance section above.

#### Air Coil

The air coil must be cleaned to obtain maximum performance. Check once a year under normal operating conditions and, if dirty, brush or vacuum (with a brush attachment) clean. Care must be taken not to damage the aluminum fins while cleaning.



**CAUTION: Fin edges are sharp.**

## Replacement Procedures

---

### Obtaining Parts

When ordering service or replacement parts, refer to the model number and serial number of the unit as stamped on the serial plate attached to the unit. If replacement parts are required, mention the date of installation of the unit and the date of failure, along with an explanation of the malfunctions and a description of the replacement parts required.

### In-Warranty Material Return

Material may not be returned except by permission of authorized warranty personnel. Contact your local distributor for warranty return authorization and assistance.

## Service Parts List

		Single Speed Split Units							Dual Capacity Split Units				
		022	030	036	042	048	060	070	026	038	049	064	072
Compressor	Compressor	34P581-01	34P582-01	34P583-01	34P578-01	34P579-01	34P580-01	34P646-01	34P640-01	34P641-01	34P642-01	34P643-01	34P644-01
	Run Capacitor	16P002-18	16P002-20		16P002-21		16P002-25	16P002-41	16P002-19	16P002-20	16P002-18	16P002-31	
	Sound Jacket	92P504A05				92P504A16			92P504A16				
	Power Harness	11P781-01							11P781-01				
	Solenoid Harness	N / A							11P782-02				
Refrigeration Components	Accumulator	36P509-02		36P509-01				36P509-02	36P509-01				
	Coax	62I594-01	62I588-01	62I542B01		62I543B01		62I555-01	62I594-01	62I54201	62I543B01		62I555-01
	TXV	33P628-02			33P628-03		33P628-04	33P628-05	33P628-01		33P628-03	33P628-04	33P628-05
	Reversing Valve	33P506-04		33P503-05		33P526-04			33P506-04	33P503-05	33P526-04		
	Filter Dryer	36P500B01				36P500B02			36P500B01		36P500B02		
	Service Valve Suction	33P554B02		33P554B03			33P554B04		33P554B02	33P554B03		33P554B04	
	Service Valve Liquid	33P554B01				33P554B05			33P554B01		33P554B05		
	Desuperheater	Desuperheater	62P516-05		62P516-03				62P516-05		62P516-03		
Desuperheater Pump		24P501-02							24P501-02				
Electrical	Contactors	13P004A03							13P004A03				
	2 Pole Screw Term. Block	12P500A01							12P500A01				
	ABC Board	17X553-16							17X553-16				
	AXB Board	17X557-17							17X557-17				
	ABC/AXB Comm. Cable	11P837-01							11P837-01				
	Circuit Breaker 5amp, 250V	19P583-01							19P583-01				
Sensors & Safeties	High Pressure Transducer Kit	SK5SHPT							SK5SHPT				
	Low Pressure Transducer Kit	SK5SLPT							SK5SLPT				
	Current Sensor	12P557-01							12P557-01				
	Thermistor Suction Line	12P555-05							12P555-05				
	Thermistor Liquid Line Heating	12P555-03							12P555-03				
	Thermistor EWT	12P560-01							12P560-01				
	Thermistor LWT	12P560-02							12P560-02				
	Thermistor Hot water Limit (HWG)	12P555-04							12P555-04				
	Freeze Detection Thermistor	12P505-09							12P505-09				
	HW Thermo-switch SPNC 130°F	13P073B05							13P073B05				
	High Pressure Switch Kit	SKHPE600							SKHPE600				
	Low Pressure Switch Kit	SKLPE40							SKLPE40				

## Notes

---

## Revision Guide

---

<b>Pages:</b>	<b>Description:</b>	<b>Date:</b>	<b>By:</b>
4	Updated Nomenclature	01 June 2021	MA
17	Updated Electronic Thermostat Installation Information	03 May 2017	MA
Misc.	Various Updates related to AHB release	15 Apr 2017	JM
All	First Published	09 Oct 2013	DS



Product: **Aston & Aston Advanced Series**  
Type: Indoor Split Geothermal/Water Source Heat Pump  
Size: 2-6 Ton Single & Two-Stage  
Document Type: Installation Manual  
Part Number: IM2503SG  
Release Date: 06/21