

# ARBOR BASE SERIES

## COMMERCIAL

Water Source/Geothermal Heat Pump

- R-410A Refrigerant
- Commercial 0.75-6 Ton

Installation Information

Water Piping Connections

Hot Water Connections

Electrical

Startup Procedures

Troubleshooting

Preventive Maintenance



# GEOSTAR

IM1201AZA 05/14



# Table of Contents

---

- Model Nomenclature . . . . . 4
- General Installation Information . . . . . 5
- Dimensional Data . . . . . 6-9
- Installing Horizontal Units . . . . . 10
- Hanger Bracket Locations . . . . . 11
- Duct System and Water Piping . . . . . 12
- Water Quality . . . . . 13
- Condensate Drain . . . . . 13
- System Cleaning and Flushing . . . . . 14
- Open Loop Ground Water Systems . . . . . 15
- Freeze Detection . . . . . 16
- Electrical Connections . . . . . 16
- Electrical Data . . . . . 17-18
- Blower Performance Data . . . . . 19-22
- 5-Speed ECM Constant Torque Motors . . . . . 23
- Wiring Schematics . . . . . 24-29
- Controls - Aurora Base Control . . . . . 30-33
- Controls - FX10 (optional) . . . . . 34-39
- Unit Startup . . . . . 40
- Operating Parameters and Operating Limits . . . . . 41
- Pressure Drop . . . . . 42
- Compressor and Thermistor Resistance . . . . . 43
- Refrigerant Circuit Guideline . . . . . 43
- Heat of Extraction/Rejection Data . . . . . 44
- Reference Calculations and Legend . . . . . 45
- Troubleshooting . . . . . 46
- Startup/Troubleshooting Form . . . . . 47-48
- Preventive Maintenance . . . . . 49
- Replacement Procedures . . . . . 49
- Service Parts . . . . . 50-51
- Revision Guide . . . . . 53

# Model Nomenclature

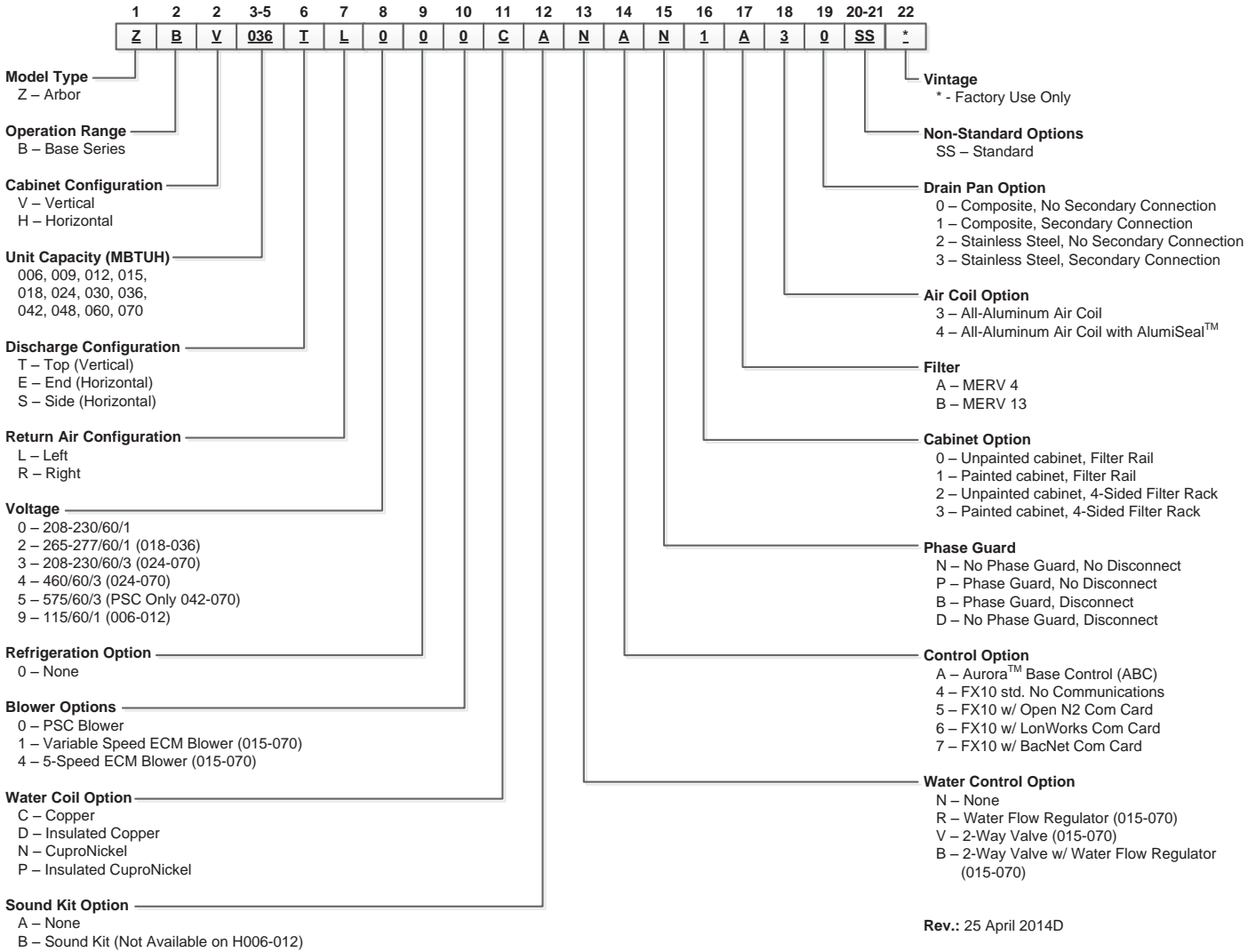

**Note:** Phase Guard Only Available on 208-230/60/3, 460/60/3, and 575/60/3 50VA Transformer with Aurora and 75VA Transformer with FX10



All Arbor Base Series product is safety listed under UL1995 thru ETL and performance listed with AHRI in accordance with standard 13256-1.

## General Installation Information

### Safety Considerations



**WARNING:** Before performing service or maintenance operations on a system, turn off main power switches to the indoor unit. If applicable, turn off the accessory heater power switch. Electrical shock could cause personal injury.

Installing and servicing heating and air conditioning equipment can be hazardous due to system pressure and electrical components. Only trained and qualified service personnel should install, repair or service heating and air conditioning equipment. Untrained personnel can perform the basic maintenance functions of cleaning coils and cleaning and replacing filters. All other operations should be performed by trained service personnel. When working on heating and air conditioning equipment, observe precautions in the literature, tags and labels attached to the unit and other safety precautions that may apply.

Follow all safety codes. Wear safety glasses and work gloves. Use a quenching cloth for brazing operations and have a fire extinguisher available.

### Moving and Storage

Move units in the normal "up" orientation. Horizontal units may be moved and stored per the information on the packaging. Do not stack more than three units in total height. Vertical units may be stored one upon another to a maximum height of two units. Do not attempt to move units while stacked. When the equipment is received, all items should be carefully checked against the bill of lading to be sure all crates and cartons have been received. Examine units for shipping damage, removing the units from the packaging if necessary. Units in question should also be internally inspected. If any damage is noted, the carrier should make the proper notation on the delivery receipt, acknowledging the damage.

### Unit Location

Locate the unit in an indoor area that allows for easy removal of the filter and access panels. Location should have enough space for service personnel to perform maintenance or repair. Provide sufficient room to make water, electrical and duct connection(s). If the unit is located in a confined space, such as a closet, provisions must be made for return air to freely enter the space by means of a louvered door, etc. Any access panel screws that would be difficult to remove after the unit is installed should be removed prior to setting the unit. On horizontal units, allow adequate room below the unit for a condensate drain trap and do not locate the unit above supply piping. Care should be taken when units are located in unconditioned spaces to prevent damage from frozen water lines and excessive heat that could damage electrical components.

### Installing Vertical Units

Vertical units are available in left or right air return configurations. Top flow vertical units should be mounted level on a vibration absorbing pad slightly larger than the base to provide isolation between the unit and the floor.

Vertical Unit Mounting

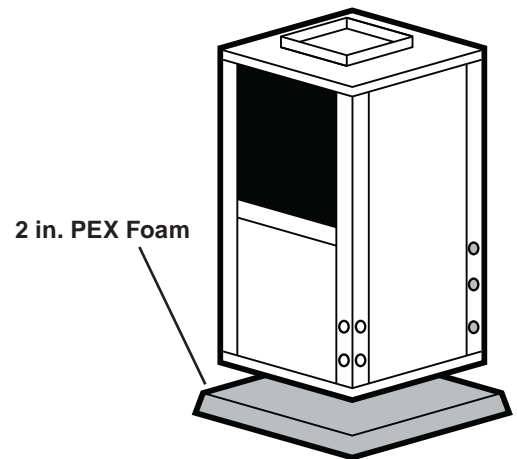

# Vertical Dimensional Data

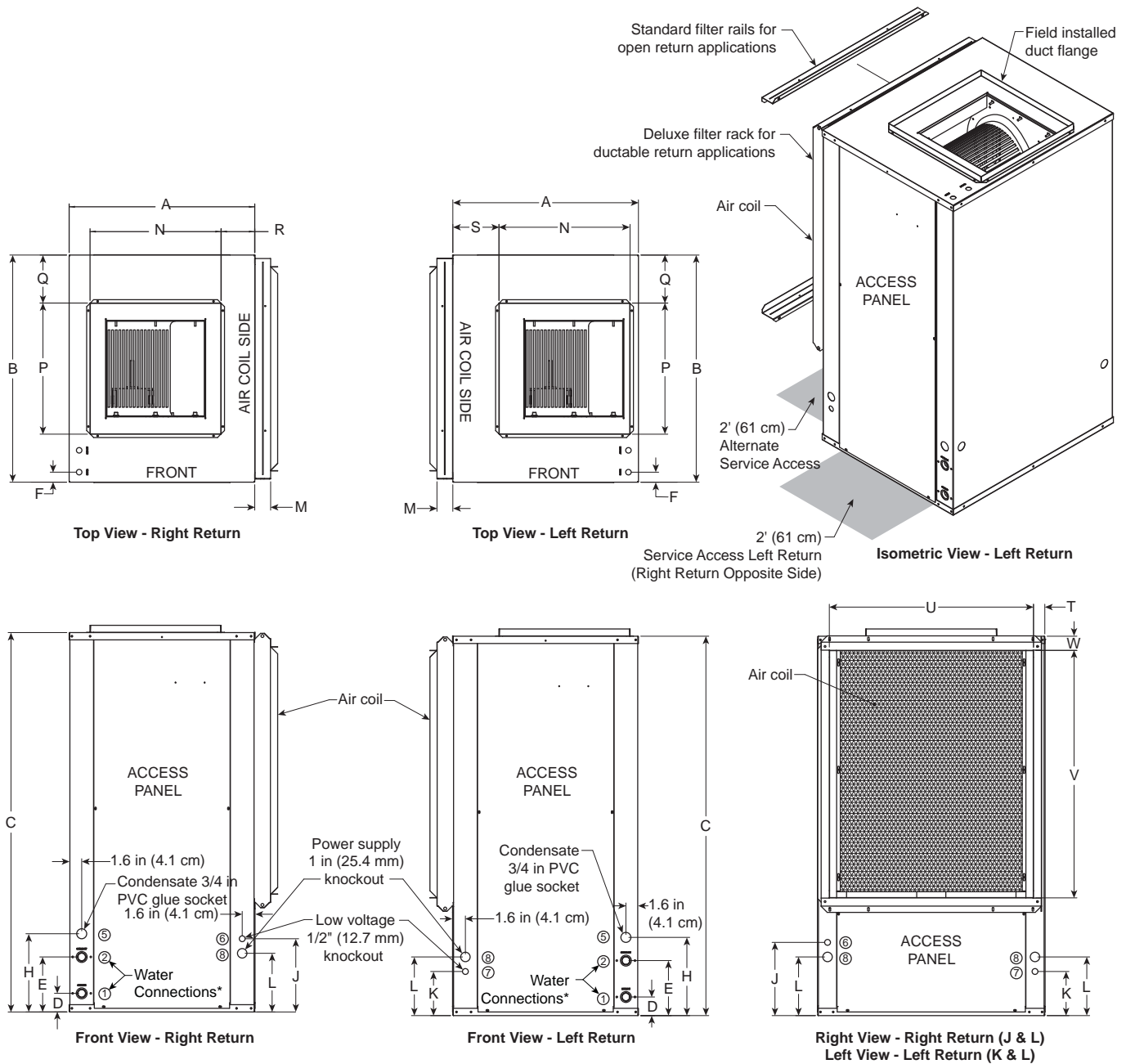

**NOTE:** \* Water connections protrude approximately 1.5 in. from cabinet.

# Vertical Dimensional Data cont.

| Vertical Models |     | Overall Cabinet |       |         | Water Connections |      |            |           | Electrical Knockouts        |                             |                            | Filter Rack Width |
|-----------------|-----|-----------------|-------|---------|-------------------|------|------------|-----------|-----------------------------|-----------------------------|----------------------------|-------------------|
|                 |     |                 |       |         | 1                 | 2    | 5          | Loop      | 6                           | 7                           | 8                          |                   |
|                 |     | A               | B     | C       | D                 | E    | H          |           | J                           | K                           | L                          |                   |
|                 |     | Width           | Depth | Height* | In                | Out  | Condensate | Water FPT | 1/2 in. cond<br>Low Voltage | 1/2 in. cond<br>Low Voltage | 1 in. cond<br>Power Supply |                   |
| 006-012         | in. | 19.2            | 19.2  | 24.2    | 2.6               | 5.6  | 8.8        | 1/2 in.   | 7.4                         | 3.4                         | 5.4                        | 2.2               |
|                 | cm. | 48.8            | 48.8  | 61.5    | 6.6               | 14.2 | 22.4       | 12.7 mm   | 18.8                        | 8.6                         | 13.7                       | 5.6               |
| 015-018         | in. | 22.5            | 22.2  | 30.2    | 2.6               | 7.6  | 10.8       | 3/4 in.   | 9.4                         | 5.4                         | 7.4                        | 2.2               |
|                 | cm. | 57.2            | 56.4  | 76.7    | 6.6               | 19.3 | 27.4       | 19.1 mm   | 23.9                        | 13.7                        | 18.8                       | 5.6               |
| 024-030         | in. | 22.5            | 22.2  | 36.2    | 2.6               | 7.6  | 10.8       | 3/4 in.   | 9.4                         | 5.4                         | 7.4                        | 2.2               |
|                 | cm. | 57.2            | 56.4  | 91.9    | 6.6               | 19.3 | 27.4       | 19.1 mm   | 23.9                        | 13.7                        | 18.8                       | 5.6               |
| 036             | in. | 22.5            | 26.2  | 40.2    | 2.6               | 7.6  | 10.8       | 3/4 in.   | 10.1                        | 6.1                         | 8.1                        | 2.2               |
|                 | cm. | 57.2            | 66.5  | 102.1   | 6.6               | 19.3 | 27.4       | 19.1 mm   | 25.7                        | 15.5                        | 20.6                       | 5.6               |
| 042-048         | in. | 22.5            | 26.2  | 44.2    | 2.6               | 7.6  | 10.8       | 3/4 in.   | 10.1                        | 6.1                         | 8.1                        | 2.2               |
|                 | cm. | 57.2            | 66.5  | 112.3   | 6.6               | 19.3 | 27.4       | 19.1 mm   | 25.7                        | 15.5                        | 20.6                       | 5.6               |
| 060             | in. | 25.5            | 31.2  | 44.2    | 2.6               | 7.6  | 10.8       | 1 in.     | 10.1                        | 6.1                         | 8.1                        | 2.2               |
|                 | cm. | 64.8            | 79.2  | 112.3   | 6.6               | 19.3 | 27.4       | 25.4 mm   | 25.7                        | 15.5                        | 20.6                       | 5.6               |
| 070             | in. | 25.5            | 31.2  | 48.2    | 2.6               | 7.6  | 10.8       | 1 in.     | 10.1                        | 6.1                         | 8.1                        | 2.2               |
|                 | cm. | 64.8            | 79.2  | 122.4   | 6.6               | 19.3 | 27.4       | 25.4 mm   | 25.7                        | 15.5                        | 20.6                       | 5.6               |

| Vertical Models |     | Discharge Connection<br>duct flange installed (±0.10 in) |              |      |      |      | **Return Connection<br>using deluxe filter rack (±0.10 in) |              |               |     |
|-----------------|-----|--|--------------|------|------|------|--|--------------|---------------|-----|
|                 |     | N  | P            | Q    | R    | S    | T  | U            | V             | W   |
|                 |     | Supply Width   | Supply Depth |      |      |      |  | Return Depth | Return Height |     |
| 006-012         | in. | 10.0   | 10.0         | 4.6  | 4.4  | 7.8  | 2.4  | 14.3         | 10.1          | 2.0 |
|                 | cm. | 25.4   | 25.4         | 11.7 | 11.2 | 19.8 | 6.1  | 36.3         | 25.7          | 5.1 |
| 015-018         | in. | 14.0   | 14.0         | 4.1  | 4.3  | 7.7  | 2.1  | 18.1         | 14.0          | 2.0 |
|                 | cm. | 35.6   | 35.6         | 10.4 | 10.9 | 19.6 | 5.3  | 46.0         | 35.6          | 5.1 |
| 024-030         | in. | 14.0   | 14.0         | 4.1  | 4.3  | 7.7  | 2.1  | 18.1         | 20.0          | 2.0 |
|                 | cm. | 35.6   | 35.6         | 10.4 | 10.9 | 19.6 | 5.3  | 46.0         | 50.8          | 5.1 |
| 036             | in. | 14.0   | 14.0         | 6.1  | 4.5  | 7.7  | 2.1  | 22.1         | 22.1          | 2.0 |
|                 | cm. | 35.6   | 35.6         | 15.5 | 11.4 | 19.6 | 5.3  | 56.1         | 56.1          | 5.1 |
| 042-048         | in. | 18.0   | 18.0         | 4.1  | 3.9  | 9.9  | 2.1  | 22.1         | 26.1          | 2.0 |
|                 | cm. | 45.7   | 45.7         | 10.4 | 9.9  | 25.1 | 5.3  | 56.1         | 66.3          | 5.1 |
| 060             | in. | 18.0   | 18.0         | 6.6  | 4.6  | 6.3  | 1.6  | 28.1         | 26.0          | 2.0 |
|                 | cm. | 45.7   | 45.7         | 16.8 | 11.7 | 16.0 | 4.1  | 71.4         | 66.0          | 5.1 |
| 070             | in. | 18.0   | 18.0         | 6.6  | 4.6  | 6.3  | 1.6  | 28.1         | 30.0          | 2.0 |
|                 | cm. | 45.7   | 45.7         | 16.8 | 11.7 | 16.0 | 4.1  | 71.4         | 76.2          | 5.1 |

09/26/12

Condensate is 3/4 in. PVC female glue socket and is switchable from side to front.

\* Discharge flange is field installed and extends 1 in. (25.4 mm) from top of cabinet.

\*\* Vertical units shipped with standard 2 in. (field adjustable to 1 in.) open application filter rail extending 2.2 in. from the unit and is not suitable for duct connection. For ductable return connection applications, order the 2 in. (field adjustable to 1 in.) duct collar/filter rack which extends to 3.25 in. from the unit and is suitable for duct connections.

## Vertical Disconnect

When using disconnect, do not use dimension L from the standard vertical dimensional data. Use dimension LL from the vertical disconnect dimensional data.

| Vertical Models | LL          |
|-----------------|-------------|
| 015-018         | 15.8 [40.1] |
| 024-030         | 18.8 [47.8] |
| 036             | 15.3 [38.9] |
| 042-048         | 13.8 [35.1] |
| 060             | 14.3 [36.3] |
| 070             | 14.3 [36.3] |

Dimensions in inches [cm]

\* Models 006-012 - Externally Mounted Disconnect

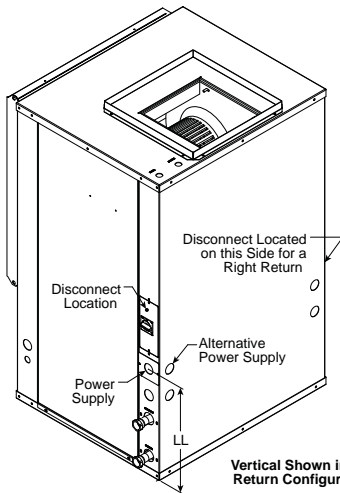

# Horizontal Dimensional Data

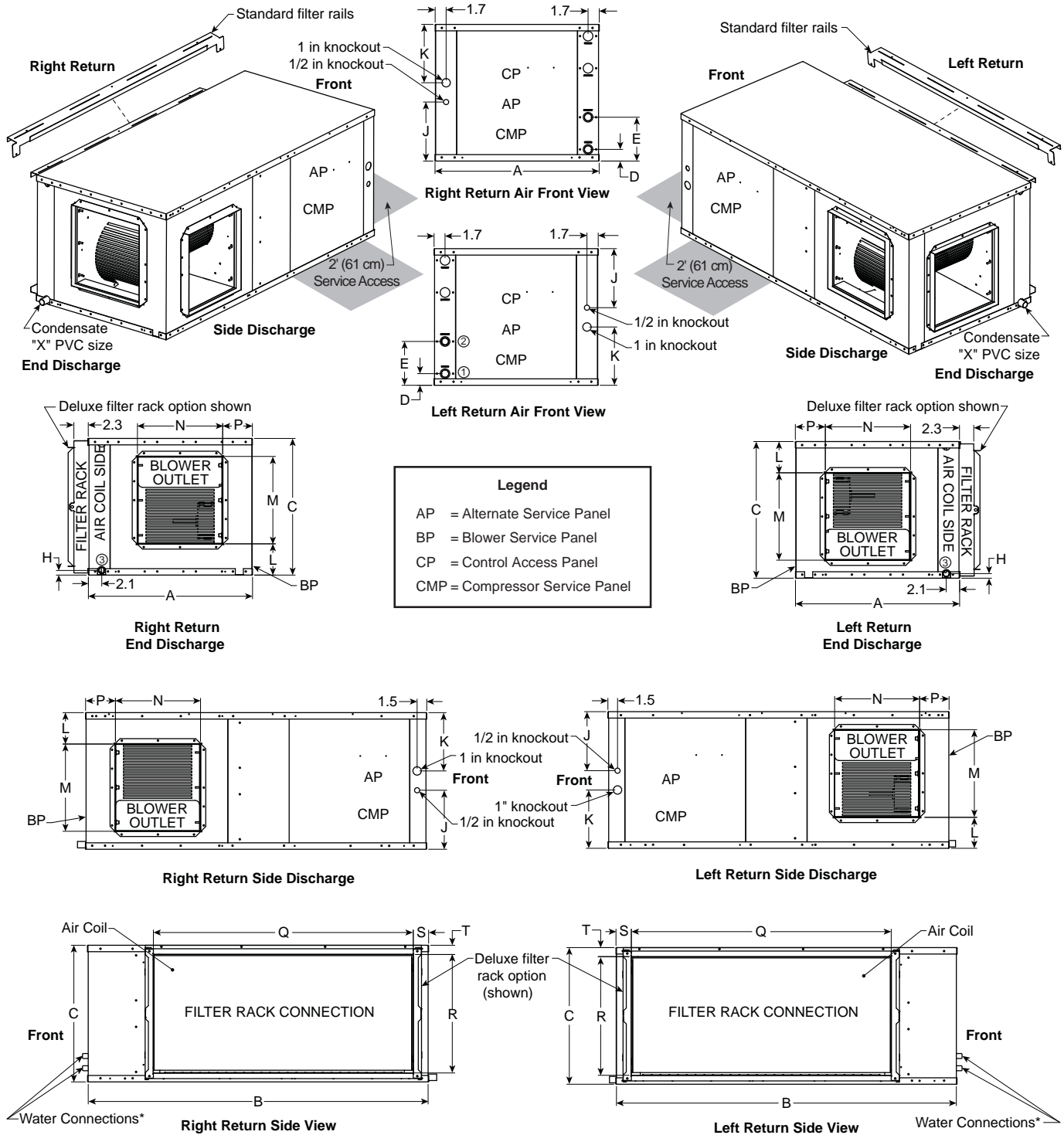

**NOTE:** \* Water connections protrude approximately 1.5 in. from cabinet.



## Horizontal Dimensional Data cont.

| Horizontal Models | Overall Cabinet |       |         | Water Connections |          |                 |                   | Electrical Knockouts        |                            |      |
|-------------------|-----------------|-------|---------|-------------------|----------|-----------------|-------------------|-----------------------------|----------------------------|------|
|                   | A               | B     | C       | 1                 | 2        | 3               | Loop<br>Water FPT | J                           | K                          |      |
|                   | Width           | Depth | Height* | D<br>In           | E<br>Out | H<br>Condensate |                   | 1/2 in. cond<br>Low Voltage | 1 in. cond<br>Power Supply |      |
| 006-012**         | in.             | 19.2  | 35.0    | 12.1              | 1.8      | 4.8             | 3.6               | 1/2 in.                     | 7.4                        | 7.5  |
|                   | cm.             | 48.8  | 88.9    | 30.7              | 4.6      | 12.2            | 9.1               | 12.70 mm                    | 18.8                       | 19.1 |
| 015-018           | in.             | 22.5  | 35.0    | 17.2              | 1.8      | 6.8             | 0.8               | 3/4 in.                     | 7.1                        | 7.1  |
|                   | cm.             | 57.2  | 88.9    | 43.7              | 4.6      | 17.3            | 2.0               | 19.05 mm                    | 18.0                       | 18.0 |
| 024-030           | in.             | 22.5  | 42.0    | 17.2              | 1.8      | 6.8             | 0.8               | 3/4 in.                     | 7.1                        | 7.1  |
|                   | cm.             | 57.2  | 106.7   | 43.7              | 4.6      | 17.3            | 2.0               | 19.05 mm                    | 18.0                       | 18.0 |
| 036               | in.             | 22.5  | 42.0    | 19.2              | 1.8      | 6.8             | 0.8               | 3/4 in.                     | 9.2                        | 7.1  |
|                   | cm.             | 57.2  | 106.7   | 48.8              | 4.6      | 17.3            | 2.0               | 19.05 mm                    | 23.4                       | 18.0 |
| 042-048           | in.             | 22.5  | 45.0    | 19.2              | 1.8      | 6.8             | 0.8               | 3/4 in.                     | 9.2                        | 7.1  |
|                   | cm.             | 57.2  | 114.3   | 48.8              | 4.6      | 17.3            | 2.0               | 19.05 mm                    | 23.4                       | 18.0 |
| 060               | in.             | 25.5  | 48.0    | 21.2              | 1.8      | 6.8             | 0.8               | 1 in.                       | 9.2                        | 9.1  |
|                   | cm.             | 64.8  | 121.9   | 53.8              | 4.6      | 17.3            | 2.0               | 25.4 mm                     | 23.4                       | 23.1 |
| 070               | in.             | 25.5  | 53.0    | 21.2              | 1.8      | 6.8             | 0.8               | 1 in.                       | 9.2                        | 9.1  |
|                   | cm.             | 64.8  | 134.6   | 53.8              | 4.6      | 17.3            | 2.0               | 25.4 mm                     | 23.4                       | 23.1 |

| Horizontal Models | Discharge Connection<br>duct flange installed (±0.10 in) |              |              |      | Return Connection<br>using deluxe filter rack option (±0.10 in) |               |      |     | PVC Size |         |
|-------------------|--|--------------|--------------|------|---|---------------|------|-----|----------|---------|
|                   | L  | M            | N            | P    | Q   | R             | S    | T   | X        |         |
|                   |  | Supply Width | Supply Depth |      | Return Depth  | Return Height |      |     |          |         |
| 006-012**         | in.  | 2.3          | 8.0          | 10.0 | 2.7   | 22.5          | 9.4  | 2.4 | 1.4      | 1/2 in. |
|                   | cm.  | 5.8          | 20.3         | 25.4 | 6.9   | 57.2          | 23.9 | 6.1 | 3.6      | 1.3     |
| 015-018           | in.  | 5.7          | 10.5         | 9.4  | 4.9   | 16.4          | 14.5 | 2.0 | 1.4      | 3/4 in. |
|                   | cm.  | 14.5         | 26.7         | 23.9 | 12.4  | 41.7          | 36.8 | 5.1 | 3.6      | 1.9     |
| 024-030           | in.  | 5.7          | 10.5         | 9.4  | 4.9   | 23.4          | 14.5 | 2.0 | 1.4      | 3/4 in. |
|                   | cm.  | 14.5         | 26.7         | 23.9 | 12.4  | 59.4          | 36.8 | 5.1 | 3.6      | 1.9     |
| 036               | in.  | 6.7          | 10.5         | 9.4  | 4.9   | 27.4          | 16.5 | 2.0 | 1.4      | 3/4 in. |
|                   | cm.  | 17.0         | 26.7         | 23.9 | 12.4  | 69.6          | 41.9 | 5.1 | 3.6      | 1.9     |
| 042-048           | in.  | 4.2          | 13.6         | 13.2 | 2.4   | 30.4          | 16.5 | 2.0 | 1.5      | 3/4 in. |
|                   | cm.  | 10.7         | 34.5         | 33.5 | 6.1   | 77.2          | 41.9 | 5.1 | 3.8      | 1.9     |
| 060               | in.  | 4.8          | 13.6         | 13.2 | 4.6   | 35.4          | 18.7 | 2.3 | 1.3      | 3/4 in. |
|                   | cm.  | 12.2         | 34.5         | 33.5 | 11.7  | 89.9          | 47.5 | 5.8 | 3.3      | 1.9     |
| 070               | in.  | 4.8          | 13.6         | 13.2 | 4.6   | 40.4          | 18.5 | 2.3 | 1.4      | 3/4 in. |
|                   | cm.  | 12.2         | 34.5         | 33.5 | 11.7  | 102.6         | 47.0 | 5.8 | 3.6      | 1.9     |

Horizontal units shipped with standard 2 in. (field adjustable to 1 in.) open application filter rail extending 2.2 in. from the unit and is not suitable for duct connection. For ductable return connection applications, order the 2 in. (field adjustable to 1 in.) duct collar/filter rack which extends to 3.25 in. from the unit and is suitable for duct connections.

09/26/12

\*\* H006-012 offers a lifted drain pan that allows the trap to be installed without additional ceiling height required.

## Horizontal Disconnect

When using disconnect, do not use dimension K from the standard horizontal dimensional data. Use dimension KK from the horizontal disconnect dimensional data.

| Horizontal Models | KK          |
|-------------------|-------------|
| 015-018           | 8.2 [20.8]  |
| 024-030           | 8.2 [20.8]  |
| 036               | 9.2 [23.4]  |
| 042-048           | 9.2 [23.4]  |
| 060               | 11.2 [28.4] |
| 070               | 10.2 [25.9] |

Dimensions in inches [cm]

\* Models 006-012 - Externally Mounted Disconnect

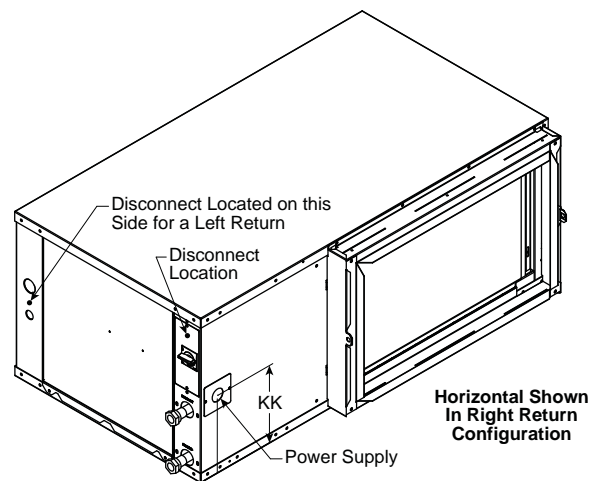

## Installing Horizontal Units

### Installing Horizontal Units

Horizontal units are available with side or end discharge and may be easily field converted by flipping the blower discharge panel. Horizontal units are normally suspended from a ceiling by four 3/8 in. diameter threaded rods. The rods are usually attached to the unit by hanger bracket kits furnished with each unit. Lay out the threaded rods per the dimensions below. Assemble the hangers to the unit as shown. Securely tighten the brackets to the unit using the weld nuts located on the underside of the bottom panel. When attaching the hanger rods to the bracket, a double nut is required since vibration could loosen a single nut.

**NOTE:** The unit should be pitched approximately 1/4 in. towards the drain in both directions to facilitate the removal of condensate.

Use only the bolts provided in the kit to attach hanger brackets. The use of longer bolts could damage internal parts. Some applications require the installation of horizontal units on an attic floor. In this case, the unit should be set in a full size secondary drain pan on top of a vibration absorbing pad. The secondary drain pan prevents possible condensate overflow or water leakage damage to the ceiling. The secondary drain pan is usually placed on a plywood base isolated from the ceiling joists by additional layers of vibration absorbing material. Insulate supply plenum and use at least one 90° elbow and flexible duct collar to reduce noise.



**CAUTION:** Do not use rods smaller than 3/8 in. diameter since they may not be strong enough to support the unit. The rods must be securely anchored to the ceiling.

### Horizontal Unit Mounting

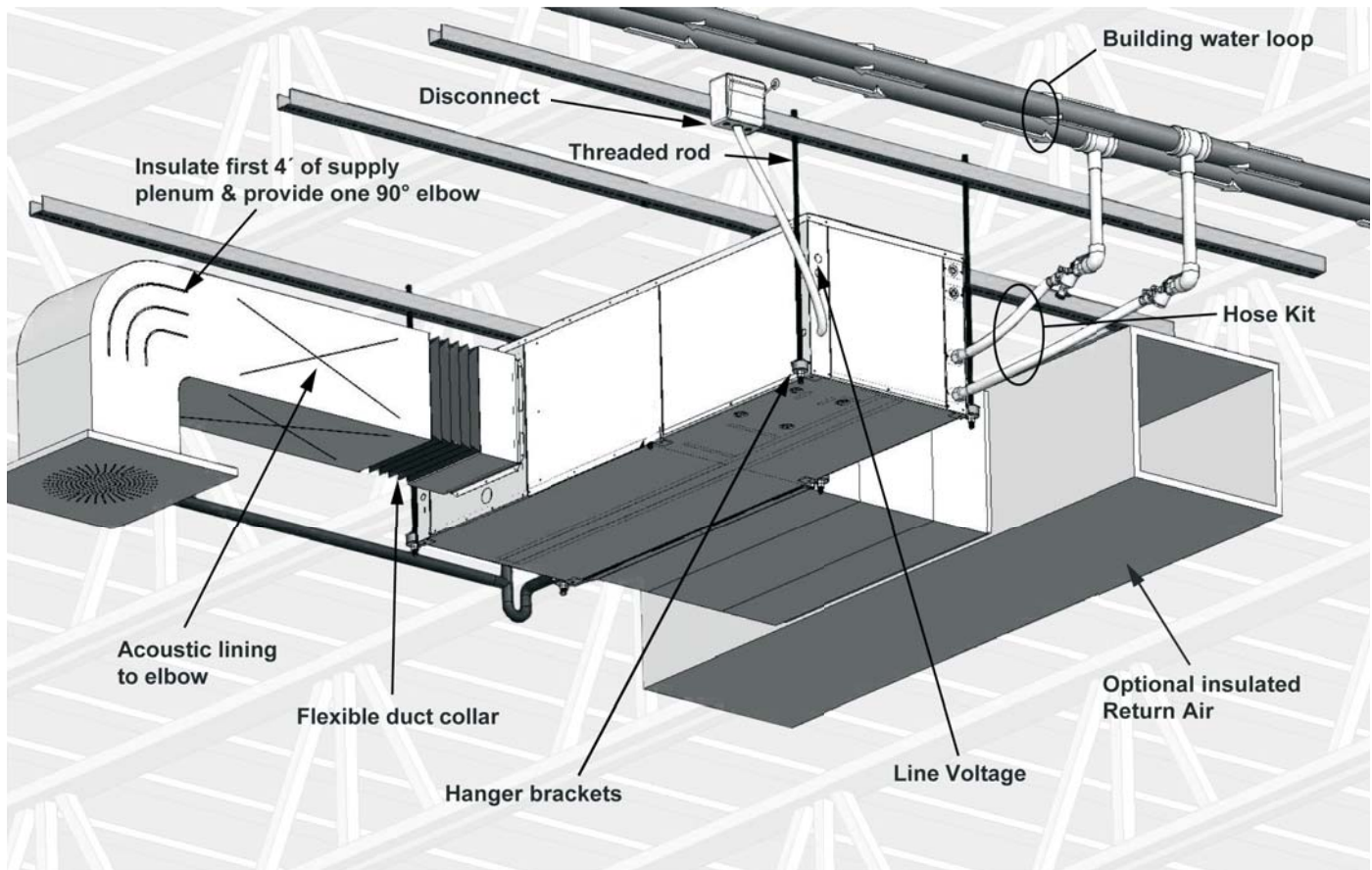

# Hanger Bracket Locations

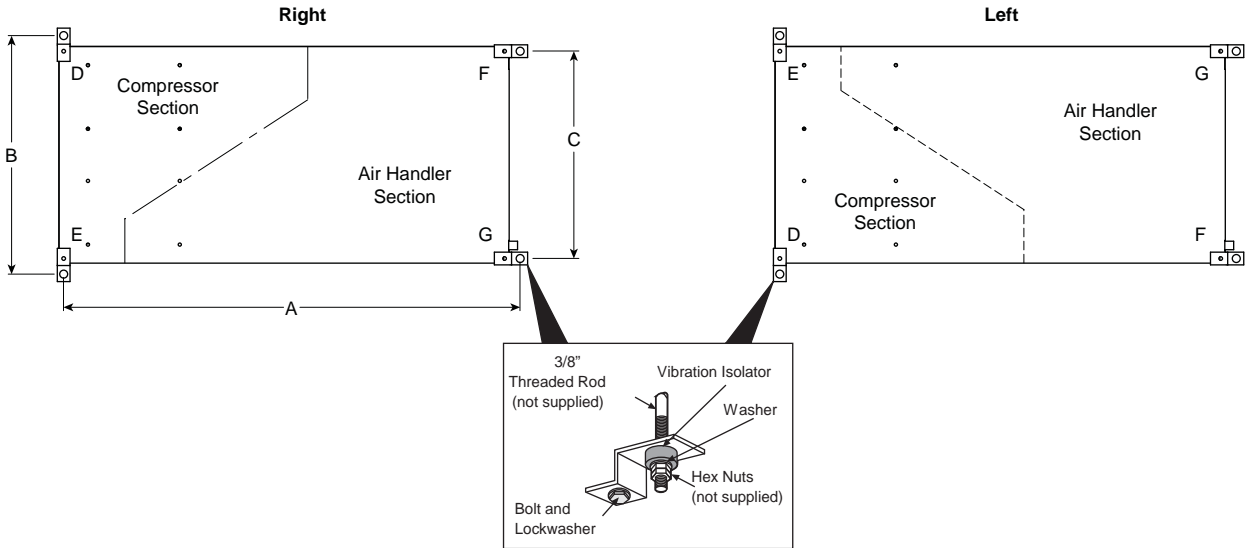

## Hanger Dimensions

| Model   | Hanger Kit Part Number | Unit Hanger Dimensions |      |      |
|---------|------------------------|------------------------|------|------|
|         |                        | A                      | B    | C    |
| 006-012 | in.                    | 35.8                   | 21.8 | 18.1 |
|         | cm.                    | 90.9                   | 55.4 | 46.0 |
| 015-018 | in.                    | 35.8                   | 25.1 | 21.4 |
|         | cm.                    | 90.9                   | 63.8 | 54.4 |
| 024-030 | in.                    | 42.8                   | 25.1 | 21.4 |
|         | cm.                    | 108.6                  | 63.8 | 54.4 |
| 036     | in.                    | 42.8                   | 25.1 | 21.4 |
|         | cm.                    | 108.7                  | 63.8 | 54.4 |
| 042-048 | in.                    | 45.8                   | 25.1 | 21.4 |
|         | cm.                    | 116.3                  | 63.8 | 54.4 |
| 060     | in.                    | 48.8                   | 28.1 | 24.4 |
|         | cm.                    | 124.0                  | 71.4 | 62.0 |
| 070     | in.                    | 53.8                   | 28.1 | 24.4 |
|         | cm.                    | 136.7                  | 71.4 | 62.0 |

09/26/12

## Weight Distribution

| Model   | Vertical Shipping Weight | Horizontal Shipping Weight | Horizontal Weight Distribution |     |      |    |    |
|---------|--------------------------|----------------------------|--------------------------------|-----|------|----|----|
|         |                          |                            | Front                          |     | Back |    |    |
|         |                          |                            | D                              | E   | F    | G  |    |
| 006-012 | lb.                      | 111                        | 112                            | 44  | 21   | 19 | 28 |
|         | kg                       | 50                         | 51                             | 20  | 10   | 9  | 12 |
| 015-018 | lb.                      | 171                        | 176                            | 67  | 32   | 32 | 45 |
|         | kg                       | 78                         | 80                             | 30  | 15   | 15 | 20 |
| 024     | lb.                      | 245                        | 242                            | 85  | 47   | 45 | 65 |
|         | kg                       | 111                        | 110                            | 39  | 21   | 20 | 29 |
| 030     | lb.                      | 245                        | 242                            | 85  | 47   | 45 | 65 |
|         | kg                       | 111                        | 110                            | 39  | 21   | 20 | 29 |
| 036     | lb.                      | 267                        | 265                            | 95  | 60   | 50 | 60 |
|         | kg                       | 121                        | 120                            | 43  | 27   | 23 | 27 |
| 042     | lb.                      | 305                        | 310                            | 105 | 68   | 60 | 77 |
|         | kg                       | 138                        | 141                            | 48  | 31   | 27 | 35 |
| 048     | lb.                      | 305                        | 310                            | 105 | 68   | 60 | 77 |
|         | kg                       | 138                        | 141                            | 48  | 31   | 27 | 35 |
| 060     | lb.                      | 344                        | 350                            | 115 | 77   | 68 | 90 |
|         | kg                       | 156                        | 159                            | 52  | 35   | 31 | 41 |
| 070     | lb.                      | 357                        | 378                            | 130 | 80   | 73 | 95 |
|         | kg                       | 162                        | 171                            | 59  | 36   | 33 | 43 |

10/03/12

## Duct System

---

An air outlet collar is provided on vertical top flow units and all horizontal units to facilitate a duct connection. A flexible connector is recommended for discharge and return air duct connections on metal duct systems. Uninsulated duct should be insulated with a minimum of 1-inch duct insulation. Application of the unit to uninsulated ductwork in an unconditioned space is not recommended as the unit's performance will be adversely affected.

If the unit is connected to existing ductwork, check the duct system to ensure that it has the capacity to accommodate the air required for the unit application. If the duct is too small, as in the replacement of heating only systems, larger ductwork should be installed. All existing ductwork should be checked for leaks and repaired if necessary.

The duct system should be sized to handle the design airflow quietly and efficiently. To maximize sound attenuation of the unit blower, the supply and return plenums should include an internal duct liner of fiberglass or constructed of ductboard for the first few feet. On systems employing a sheet metal duct system, canvas connectors should be used between the unit and the ductwork. If air noise or excessive airflow is a problem, the blower speed can be changed.

## Water Piping

---

The proper water flow must be provided to each unit whenever the unit operates. To assure proper flow, use pressure/temperature ports to determine the flow rate. These ports should be located at the supply and return water connections on the unit. The proper flow rate cannot be accurately set without measuring the water pressure drop through the refrigerant-to-water heat exchanger.

All source water connections on commercial units are fittings that accept a male pipe thread (MPT). Insert the connectors by hand, then tighten the fitting with a wrench to provide a leakproof joint. When connecting to an open loop (groundwater) system, thread any copper MPT fitting into the connector and tighten in the same manner as described above.

# Water Quality

In ground water situations where scaling could be heavy or where biological growth such as iron bacteria will be present, a closed loop system is recommended. The heat exchanger coils in ground water systems may, over a period of time, lose heat exchange capabilities due to a buildup of mineral deposits inside. These can be cleaned, but only by a qualified service mechanic, as special solutions and pumping equipment are required. Hot water generator coils can likewise become scaled and possibly plugged.

In areas with extremely hard water, the owner should be informed that the heat exchanger may require occasional flushing. Failure to adhere to the guidelines in the water quality table could result in loss of warranty.

Units with cupronickel heat exchangers are recommended for open loop applications due to the increased resistance to build-up and corrosion, along with reduced wear caused by acid cleaning.

| Material                         |   | Copper  | 90/10 Cupronickel   | 316 Stainless Steel                                       |
|----------------------------------|---|---|---|---|
| pH                               | Acidity/Alkalinity  | 7 - 9   | 7 - 9   | 7 - 9   |
| Scaling                          | Calcium and Magnesium Carbonate                           | (Total Hardness) less than 350 ppm                        | (Total Hardness) less than 350 ppm                        | (Total Hardness) less than 350 ppm                        |
| Corrosion                        | Hydrogen Sulfide  | Less than 0.5 ppm (rotten egg smell appears at 0.5 ppm)   | 10 - 50 ppm   | Less than 1 ppm   |
|                                  | Sulfates  | Less than 125 ppm   | Less than 125 ppm   | Less than 200 ppm   |
|                                  | Chlorine  | Less than 0.5 ppm   | Less than 0.5 ppm   | Less than 0.5 ppm   |
|                                  | Chlorides   | Less than 20 ppm  | Less than 125 ppm   | Less than 300 ppm   |
|                                  | Carbon Dioxide  | Less than 50 ppm  | 10 - 50 ppm   | 10 - 50 ppm   |
|                                  | Ammonia   | Less than 2 ppm   | Less than 2 ppm   | Less than 20 ppm  |
|                                  | Ammonia Chloride  | Less than 0.5 ppm   | Less than 0.5 ppm   | Less than 0.5 ppm   |
|                                  | Ammonia Nitrate   | Less than 0.5 ppm   | Less than 0.5 ppm   | Less than 0.5 ppm   |
|                                  | Ammonia Hydroxide   | Less than 0.5 ppm   | Less than 0.5 ppm   | Less than 0.5 ppm   |
|                                  | Ammonia Sulfate   | Less than 0.5 ppm   | Less than 0.5 ppm   | Less than 0.5 ppm   |
| Iron Fouling (Biological Growth) | Total Dissolved Solids (TDS)                              | Less than 1000 ppm  | 1000 - 1500 ppm   | 1000 - 1500 ppm   |
|                                  | LSI Index   | +0.5 to -0.5  | +0.5 to -0.5  | +0.5 to -0.5  |
| Iron Fouling (Biological Growth) | Iron, FE <sup>2+</sup> (Ferrous) Bacterial Iron Potential | < 0.2 ppm   | < 0.2 ppm   | < 0.2 ppm   |
|                                  | Iron Oxide  | Less than 1 ppm, above this level deposition will occur   | Less than 1 ppm, above this level deposition will occur   | Less than 1 ppm, above this level deposition will occur   |
| Erosion                          | Suspended Solids  | Less than 10 ppm and filtered for max. of 600 micron size | Less than 10 ppm and filtered for max. of 600 micron size | Less than 10 ppm and filtered for max. of 600 micron size |
|                                  | Threshold Velocity (Fresh Water)                          | < 6 ft/sec  | < 6 ft/sec  | < 6 ft/sec  |

NOTES: Grains = ppm divided by 17  
mg/L is equivalent to ppm

2/22/12

# Condensate Drain

On vertical units, the internal condensate drain assembly consists of a drain tube which is connected to the drain pan, a 3/4 in. PVC female adapter and a flexible connecting hose. The female adapter may exit either the front or the side of the cabinet. The adapter should be glued to the field-installed PVC condensate piping. On vertical units, a condensate hose is inside all cabinets as a trapping loop; therefore, an external trap is not necessary.

On horizontal units, a PVC stub or stainless steel tube is provided for condensate drain piping connection. An external trap is required (see below). If a vent is necessary, an open stand pipe may be applied to a tee in the field-installed condensate piping.

**NOTE:** All units equipped with electronic condensate overflow protection.

## Horizontal Drain Connection (Composite Drain Pan)

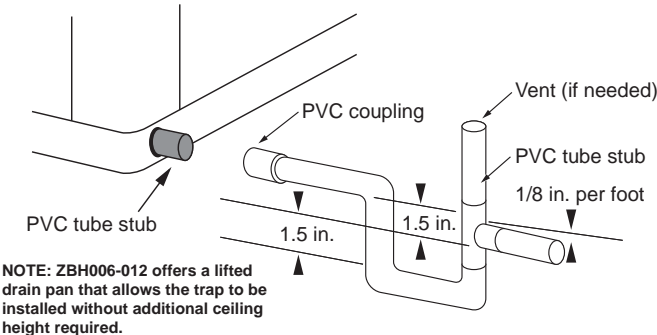

## Unit Pitch for Drain

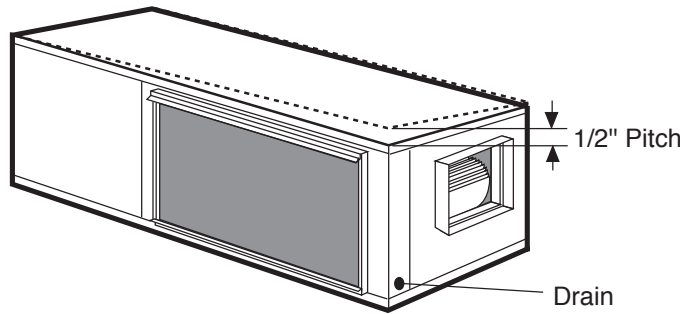

## System Cleaning and Flushing

### Cleaning and Flushing

Prior to start up of any heat pump, the water circulating system must be cleaned and flushed of all dirt and debris.

If the system is equipped with water shutoff valves, the supply and return runouts must be connected together at each unit location (This will prevent the introduction of dirt into the unit, see Flushing with Water Shutoff Valve Equipped Systems illustration). The system should be filled at the water make-up connection with all air vents open. After filling, vents should be closed.

### Flushing with Water Shutoff Valve Equipped Systems

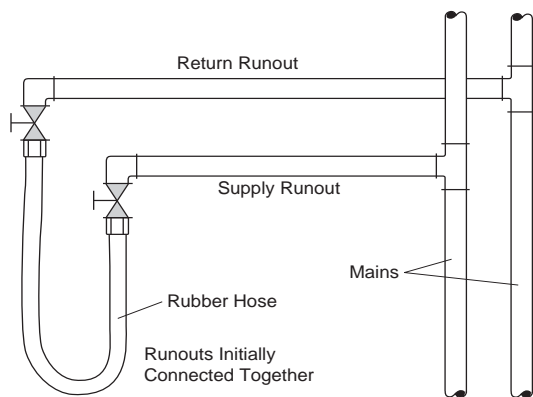

The contractor should start the main circulator with the pressure reducing valve makeup open. Vents should be checked in sequence to bleed off any trapped air and to verify circulation through all components of the system.

As water circulates through the system, the contractor should check and repair any leaks found in the piping system. Drain(s) at the lowest point(s) in the system should be opened for initial flush and blowdown, making sure water fill valves are set at the same rate. Check the pressure gauge at the pump suction and manually adjust the make-up water valve to hold the same positive pressure both before and after opening the drain valves. Flushing should continue for at least two hours, or longer if required, until drain water is clean and clear.

The supplemental heater and/or circulator pump, if used, should be shut off. All drains and vents should be opened to completely drain the system. Short-circuited supply and return runouts should now be connected to the unit supply and return connections.

Refill the system with clean water. Test the system water for acidity and treat as required to leave the water slightly alkaline (pH 7.5 to 8.5). The specified percentage of antifreeze may also be added at this time. Use commercial grade antifreeze designed for HVAC systems only. Environol™ brand antifreeze is recommended.

Once the system has been filled with clean water and antifreeze (if used), precautions should be taken to protect the system from dirty water conditions. Dirty water will result in system-wide degradation of performance, and solids may clog valves, strainers, flow regulators, etc. Additionally, the heat exchanger may become clogged which reduces compressor service life and can cause premature unit failure.

In boiler/tower application, set the loop control panel set points to desired temperatures. Supply power to all motors and start the circulating pumps. After full flow has been established through all components including the heat rejector (regardless of season), air vented and loop temperatures stabilized, each of the units will be ready for check, test and start up and for air and water balancing.

### Ground Source Loop System Checkout

Once piping is completed between the unit pumping system and ground loop, final purging and charging of the loop is needed. A high pressure pump is needed to achieve adequate flow velocity in the loop to purge air and dirt particles from the loop itself. Antifreeze solution is used in most areas to prevent freezing. Flush the system adequately to remove as much air as possible; then pressurize the loop to a static pressure of 40-50 PSI (summer) or 50-75 PSI (winter). This is normally adequate for good system operation. Loop static pressure may decrease soon after initial installation, due to pipe expansion and loop temperature change. Running the unit for at least 30 minutes after the system has been completely purged of air will allow for the "break-in" period. It may be necessary to adjust static loop pressure (by adding water) after the unit has run for the first time. Loop static pressure will also fluctuate with the seasons. Pressures will be higher in the winter months than during the cooling season. This fluctuation is normal and should be considered when charging the system initially.

Ensure the pump provides adequate flow through the unit by checking pressure drop across the heat exchanger. Usually 2.25-3.0 gpm of flow per ton of cooling capacity is recommended in earth loop applications.

# Open Loop Ground Water Systems

Typical open loop piping is shown below. Always maintain water pressure in the heat exchanger by placing water control valves at the outlet of the unit to prevent mineral precipitation. Use a closed, bladder-type expansion tank to minimize mineral formation due to air exposure. Insure proper water flow through the unit by checking pressure drop across the heat exchanger and comparing it to the figures in unit capacity data tables in the specification catalog. 1.5-2 gpm of flow per ton of cooling capacity is recommended in open loop applications. Due to only minor differences in flow rate from low to high, only one solenoid valve should be used. The valve should be sized for full flow.

Discharge water from the unit is not contaminated in any manner and can be disposed of in various ways, depending on local codes, i.e. recharge well, storm sewer, drain field, adjacent stream or pond, etc. Most local codes forbid the use of sanitary sewer for disposal. Consult your local building and zoning departments to assure compliance in your area.

## Open System - Groundwater Application

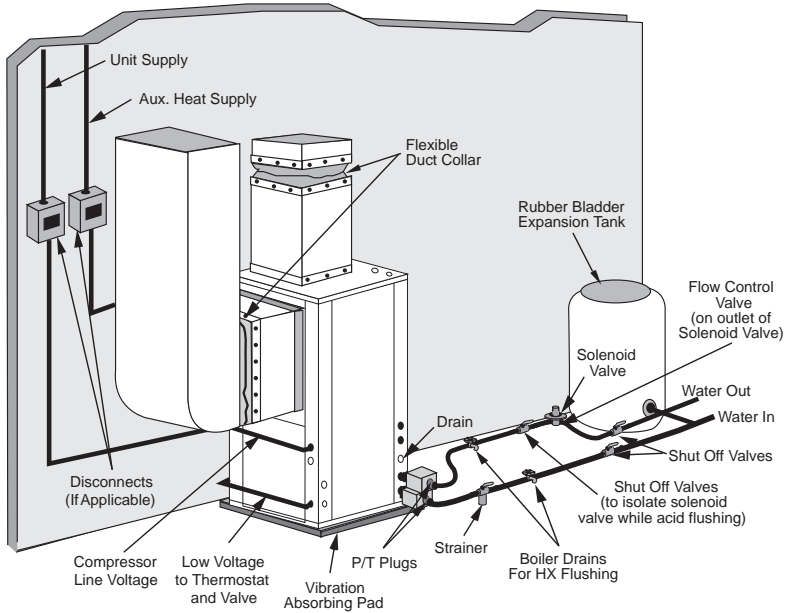

## Freeze Detection

For Aurora Base Control, set SW2-1, FP1, on the printed circuit board for applications using a closed loop antifreeze solution to 15°F [-9.4°C]. On applications using an open loop/ground water system (or closed loop no antifreeze), set this dip switch to 30°F [-1.1°C], the factory default setting. (Refer to the Dip Switch Field Selection table).

For FX10 board, the “red” wire must be removed from PB2-3 to change from 30°F [-1.1°C], the factory default setting, to 15°F [-9.4°C].

## Electrical Connections

### General

Be sure the available power is the same voltage and phase as that shown on the unit serial plate. Line and low voltage wiring must be done in accordance with local codes or the National Electric Code, whichever is applicable.

### Power Connection

Connect the incoming line voltage wires to L1 and L2 of the contactor for single-phase unit. Consult the Electrical Data tables for correct fuse sizes.

### 208 Volt Operation

All Arbor Base Series 208/230 units are factory wired for 230 volt operation. For 208 volt operation, the red and blue transformer wires must be switched on terminal strip PS.



**CAUTION:** When installing a unit with a variable speed ECM blower motor in 460/60/3 voltage, a neutral wire is required to allow proper unit operation.

#### Aurora Base Control Box

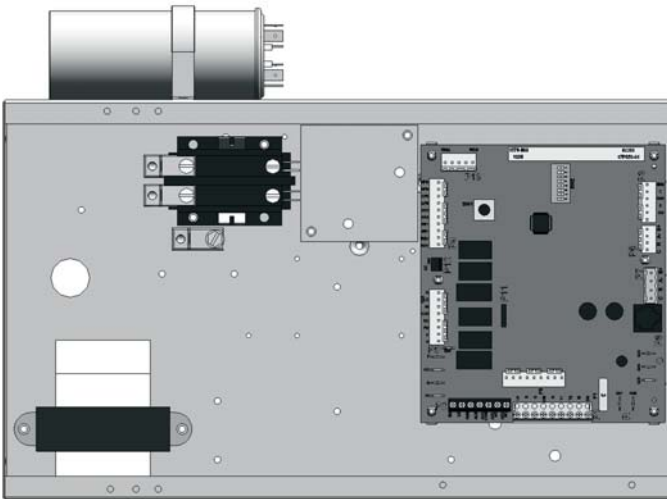

#### FX10 Control Box

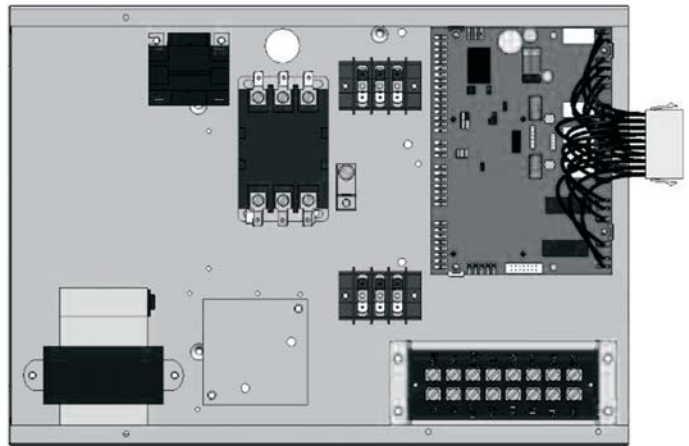



## Electrical Data

### PSC Motor

| Model | Rated Voltage | Voltage Min/Max | Compressor |      |       | Blower Motor FLA | Total Unit FLA | Min Circ Amp | Max Fuse/HACR |
|-------|---------------|-----------------|------------|------|-------|------------------|----------------|--------------|---------------|
|       |               |                 | MCC        | RLA  | LRA   |                  |                |              |               |
| 006   | 115/60/1      | 104/127         | 9.5        | 6.1  | 29.0  | 1.5              | 7.6            | 9.1          | 15            |
|       | 208-230/60/1  | 198/253         | 4.7        | 3.0  | 15.0  | 0.6              | 3.6            | 4.4          | 10/15         |
|       | 265/60/1      | 238/292         | 4.2        | 2.7  | 11.0  | 0.6              | 3.3            | 4.0          | 10/15         |
| 009   | 115/60/1      | 104/127         | 12.5       | 8.0  | 50.0  | 1.5              | 9.5            | 11.5         | 15            |
|       | 208-230/60/1  | 198/253         | 6.4        | 4.1  | 21.0  | 0.6              | 4.7            | 5.7          | 10/15         |
|       | 265/60/1      | 238/292         | 6.7        | 4.3  | 22.0  | 0.6              | 4.9            | 6.0          | 10/15         |
| 012   | 115/60/1      | 104/127         | 14.8       | 9.5  | 50.0  | 1.5              | 11.0           | 13.4         | 20            |
|       | 208-230/60/1  | 198/253         | 7.7        | 4.9  | 25.0  | 0.6              | 5.5            | 6.7          | 10/15         |
|       | 265/60/1      | 238/292         | 7.0        | 4.5  | 22.0  | 0.6              | 5.1            | 6.2          | 10/15         |
| 015   | 208-230/60/1  | 198/253         | 9.2        | 5.9  | 29.0  | 1.1              | 7.8            | 9.5          | 15            |
|       | 265/60/1      | 238/292         | 7.8        | 5.0  | 28.0  | 1.0              | 6.6            | 8.0          | 10/15         |
| 018   | 208-230/60/1  | 198/253         | 10.4       | 6.7  | 33.5  | 1.1              | 7.8            | 9.5          | 15            |
|       | 265/60/1      | 238/292         | 8.7        | 5.6  | 28.0  | 1.0              | 6.6            | 8.0          | 10/15         |
| 024   | 208-230/60/1  | 198/253         | 13.0       | 7.4  | 43.0  | 1.2              | 8.6            | 10.5         | 15            |
|       | 265/60/1      | 238/292         | 12.6       | 6.7  | 46.0  | 1.1              | 7.8            | 9.5          | 15            |
|       | 208-230/60/3  | 187/253         | 13.0       | 5.9  | 63.0  | 1.2              | 7.1            | 8.6          | 10/15         |
|       | 460/60/3      | 414/506         | 6.0        | 2.9  | 30.0  | 0.6              | 3.5            | 4.2          | 10/15         |
| 030   | 208-230/60/1  | 198/253         | 17.5       | 9.4  | 54.0  | 1.5              | 10.9           | 13.3         | 20            |
|       | 265/60/1      | 238/292         | 14.0       | 8.0  | 46.0  | 1.5              | 9.5            | 11.5         | 15            |
|       | 208-230/60/3  | 187/253         | 13.5       | 6.6  | 63.0  | 1.5              | 8.1            | 9.8          | 15            |
|       | 460/60/3      | 414/506         | 6.4        | 3.2  | 30.0  | 1.0              | 4.2            | 5.0          | 10/15         |
| 036   | 208-230/60/1  | 198/253         | 20.5       | 11.6 | 74.0  | 2.2              | 13.8           | 16.7         | 25            |
|       | 265/60/1      | 238/292         | 17.7       | 9.9  | 67.0  | 1.1              | 11.0           | 13.5         | 20            |
|       | 208-230/60/3  | 187/253         | 13.5       | 7.4  | 68.0  | 2.2              | 9.6            | 11.5         | 15            |
|       | 460/60/3      | 414/506         | 7.1        | 3.8  | 34.0  | 1.1              | 4.9            | 5.9          | 10/15         |
| 042   | 208-230/60/1  | 198/253         | 25.0       | 13.0 | 88.0  | 3.5              | 16.5           | 19.8         | 30            |
|       | 208-230/60/3  | 187/253         | 14.5       | 8.6  | 68.0  | 3.5              | 12.1           | 14.3         | 20            |
|       | 460/60/3      | 342/506         | 7.7        | 4.2  | 34.0  | 1.8              | 6.0            | 7.1          | 10/15         |
|       | 575/60/3      | 517/633         | 6.0        | 3.5  | 28.0  | 1.4              | 4.9            | 5.8          | 10/15         |
| 048   | 208-230/60/1  | 198/253         | 24.5       | 15.7 | 84.0  | 3.5              | 19.2           | 23.1         | 35            |
|       | 208-230/60/3  | 187/253         | 17.5       | 11.0 | 88.0  | 3.5              | 14.5           | 17.3         | 25            |
|       | 460/60/3      | 342/506         | 8.0        | 5.6  | 44.0  | 1.8              | 7.4            | 8.8          | 10/15         |
|       | 575/60/3      | 517/633         | 7.0        | 4.4  | 36.0  | 1.9              | 5.8            | 6.9          | 10/15         |
| 060   | 208-230/60/1  | 198/253         | 33.0       | 21.1 | 105.0 | 5.9              | 27.0           | 32.3         | 50            |
|       | 208-230/60/3  | 187/253         | 22.0       | 12.9 | 88.0  | 5.9              | 18.8           | 22.0         | 30            |
|       | 460/60/3      | 342/506         | 12.0       | 6.7  | 55.0  | 3.0              | 9.7            | 11.4         | 15            |
|       | 575/60/3      | 517/633         | 7.5        | 5.1  | 36.0  | 1.9              | 7.0            | 8.3          | 10/15         |
| 070   | 208-230/60/1  | 198/253         | 36.0       | 23.0 | 130.0 | 5.9              | 28.9           | 34.7         | 50            |
|       | 208-230/60/3  | 187/253         | 24.6       | 14.3 | 110.0 | 5.9              | 20.2           | 23.8         | 35            |
|       | 460/60/3      | 342/506         | 11.5       | 7.1  | 55.0  | 3.0              | 10.1           | 11.9         | 15            |
|       | 575/60/3      | 517/633         | 8.7        | 5.6  | 43.0  | 1.9              | 7.5            | 8.9          | 10/15         |

HACR circuit breaker in USA only

10/03/12

## Electrical Data cont.

### 5-Speed ECM Motor

| Model | Rated Voltage | Voltage Min/Max | Compressor |      |       | Blower Motor FLA | Total Unit FLA | Min Circ Amp | Max Fuse/HACR |
|-------|---------------|-----------------|------------|------|-------|------------------|----------------|--------------|---------------|
|       |               |                 | MCC        | RLA  | LRA   |                  |                |              |               |
| 015   | 208-230/60/1  | 198/253         | 9.2        | 5.9  | 29.0  | 4.1              | 10.0           | 11.5         | 15            |
|       | 265/60/1      | 238/292         | 7.8        | 5.0  | 28.0  | 3.6              | 8.6            | 9.8          | 10/15         |
| 018   | 208-230/60/1  | 198/253         | 10.4       | 6.7  | 33.5  | 4.1              | 10.8           | 12.5         | 15            |
|       | 265/60/1      | 238/292         | 8.7        | 5.6  | 28.0  | 3.6              | 9.2            | 10.6         | 10/15         |
| 024   | 208-230/60/1  | 198/253         | 13.0       | 7.4  | 43.0  | 4.1              | 11.5           | 13.4         | 20            |
|       | 265/60/1      | 238/292         | 12.6       | 6.7  | 46.0  | 3.6              | 10.3           | 12.0         | 15            |
|       | 208-230/60/3  | 187/253         | 13.0       | 5.9  | 63.0  | 4.1              | 10.0           | 11.5         | 15            |
|       | 460/60/3      | 414/506         | 6.0        | 2.9  | 30.0  | 2.1              | 5.0            | 5.7          | 10/15         |
| 030   | 208-230/60/1  | 198/253         | 17.5       | 9.4  | 54.0  | 4.1              | 13.5           | 15.9         | 25            |
|       | 265/60/1      | 238/292         | 14.0       | 8.0  | 46.0  | 3.6              | 11.6           | 13.6         | 20            |
|       | 208-230/60/3  | 187/253         | 13.5       | 6.6  | 63.0  | 4.1              | 10.7           | 12.4         | 15            |
|       | 460/60/3      | 414/506         | 6.4        | 3.2  | 30.0  | 2.1              | 5.3            | 6.1          | 10/15         |
| 036   | 208-230/60/1  | 198/253         | 20.5       | 11.6 | 74.0  | 4.1              | 15.7           | 18.6         | 30            |
|       | 265/60/1      | 238/292         | 17.7       | 9.9  | 67.0  | 3.6              | 13.5           | 16.0         | 25            |
|       | 208-230/60/3  | 187/253         | 13.5       | 7.4  | 68.0  | 4.1              | 11.5           | 13.4         | 20            |
|       | 460/60/3      | 414/506         | 7.1        | 3.8  | 34.0  | 2.1              | 5.9            | 6.9          | 10/15         |
| 042   | 208-230/60/1  | 198/253         | 25.0       | 13.0 | 88.0  | 7.6              | 20.6           | 23.9         | 35            |
|       | 208-230/60/3  | 187/253         | 14.5       | 8.6  | 68.0  | 7.6              | 16.2           | 18.4         | 25            |
|       | 460/60/3      | 414/506         | 7.7        | 4.2  | 34.0  | 4.0              | 8.2            | 9.3          | 10/15         |
| 048   | 208-230/60/1  | 198/253         | 24.5       | 15.7 | 84.0  | 7.6              | 23.3           | 27.2         | 40            |
|       | 208-230/60/3  | 187/253         | 17.5       | 11.0 | 88.0  | 7.6              | 18.6           | 21.4         | 30            |
|       | 460/60/3      | 414/506         | 8.0        | 5.6  | 44.0  | 4.0              | 9.6            | 11.0         | 15            |
| 060   | 208-230/60/1  | 198/253         | 33.0       | 21.1 | 105.0 | 7.6              | 28.7           | 34.0         | 50            |
|       | 208-230/60/3  | 187/253         | 22.0       | 12.9 | 88.0  | 7.6              | 20.5           | 23.7         | 35            |
|       | 460/60/3      | 414/506         | 12.0       | 6.7  | 55.0  | 4.0              | 10.7           | 12.4         | 15            |
| 070   | 208-230/60/1  | 198/253         | 36.0       | 23.0 | 130.0 | 7.6              | 30.6           | 36.4         | 50            |
|       | 208-230/60/3  | 187/253         | 24.6       | 14.3 | 110.0 | 7.6              | 21.9           | 25.5         | 35            |
|       | 460/60/3      | 414/506         | 11.5       | 7.1  | 55.0  | 4.0              | 11.1           | 12.9         | 20            |

HACR circuit breaker in USA only

10/03/12

## Electrical Data cont.

### Variable Speed ECM Motor

| Model | Rated Voltage | Voltage Min/Max | Compressor |      |       | Blower Motor FLA | Total Unit FLA | Min Circ Amp | Max Fuse/HACR |
|-------|---------------|-----------------|------------|------|-------|------------------|----------------|--------------|---------------|
|       |               |                 | MCC        | RLA  | LRA   |                  |                |              |               |
| 015   | 208-230/60/1  | 198/253         | 9.2        | 5.9  | 29.0  | 4.0              | 9.9            | 11.4         | 15            |
|       | 265/60/1      | 238/292         | 7.8        | 5.0  | 28.0  | 4.1              | 9.1            | 10.3         | 15            |
| 018   | 208-230/60/1  | 198/253         | 10.4       | 6.7  | 33.5  | 4.0              | 10.7           | 12.4         | 15            |
|       | 265/60/1      | 238/292         | 8.7        | 5.6  | 28.0  | 4.1              | 9.7            | 11.1         | 15            |
| 024   | 208-230/60/1  | 198/253         | 13.0       | 7.4  | 43.0  | 4.0              | 11.4           | 13.3         | 20            |
|       | 265/60/1      | 238/292         | 12.6       | 6.7  | 46.0  | 4.1              | 10.8           | 12.5         | 20            |
|       | 208-230/60/3  | 187/253         | 13.0       | 5.9  | 63.0  | 4.0              | 9.9            | 11.4         | 15            |
|       | 460/60/3      | 414/506         | 6.0        | 2.9  | 30.0  | 4.1              | 7.0            | 7.7          | 10/15         |
| 030   | 208-230/60/1  | 198/253         | 17.5       | 9.4  | 54.0  | 4.0              | 13.4           | 15.8         | 25            |
|       | 265/60/1      | 238/292         | 14.0       | 8.0  | 46.0  | 4.1              | 12.1           | 14.1         | 20            |
|       | 208-230/60/3  | 187/253         | 13.5       | 6.6  | 63.0  | 4.0              | 10.6           | 12.3         | 20            |
|       | 460/60/3      | 414/506         | 6.4        | 3.2  | 30.0  | 4.1              | 7.3            | 8.1          | 10/15         |
| 036   | 208-230/60/1  | 198/253         | 20.5       | 11.6 | 74.0  | 4.0              | 15.6           | 18.5         | 30            |
|       | 265/60/1      | 238/292         | 17.7       | 9.9  | 67.0  | 4.1              | 14.0           | 16.5         | 25            |
|       | 208-230/60/3  | 187/253         | 13.5       | 7.4  | 68.0  | 4.0              | 11.4           | 13.3         | 20            |
|       | 460/60/3      | 414/506         | 7.1        | 3.8  | 34.0  | 4.1              | 7.9            | 8.9          | 15            |
| 042   | 208-230/60/1  | 198/253         | 25.0       | 13.0 | 88.0  | 4.0              | 17.0           | 20.3         | 35            |
|       | 208-230/60/3  | 187/253         | 14.5       | 8.6  | 68.0  | 4.0              | 12.6           | 14.8         | 25            |
|       | 460/60/3      | 414/506         | 7.7        | 4.2  | 34.0  | 4.1              | 8.3            | 9.4          | 15            |
| 048   | 208-230/60/1  | 198/253         | 24.5       | 15.7 | 84.0  | 4.0              | 19.7           | 23.6         | 40            |
|       | 208-230/60/3  | 187/253         | 17.5       | 11.0 | 88.0  | 4.0              | 15.0           | 17.8         | 30            |
|       | 460/60/3      | 414/506         | 8.0        | 5.6  | 44.0  | 4.1              | 9.7            | 11.1         | 15            |
| 060   | 208-230/60/1  | 198/253         | 33.0       | 21.1 | 105.0 | 7.0              | 28.1           | 33.4         | 55            |
|       | 208-230/60/3  | 187/253         | 22.0       | 12.9 | 88.0  | 7.0              | 19.9           | 23.1         | 35            |
|       | 460/60/3      | 414/506         | 12.0       | 6.7  | 55.0  | 6.9              | 13.6           | 15.3         | 25            |
| 070   | 208-230/60/1  | 198/253         | 36.0       | 23.0 | 130.0 | 7.0              | 30.0           | 35.8         | 60            |
|       | 208-230/60/3  | 187/253         | 24.6       | 14.3 | 110.0 | 7.0              | 21.3           | 24.9         | 40            |
|       | 460/60/3      | 414/506         | 11.5       | 7.1  | 55.0  | 6.9              | 14.0           | 15.8         | 25            |

HACR circuit breaker in USA only

10/03/12



**CAUTION:** When installing a unit with an variable speed ECM blower motor in 460/60/3 voltage, a neutral wire is required to allow proper unit operation.

# Blower Performance Data

## Standard PSC Motor

| Model | Blower Spd | Blower Size | Motor HP | Airflow (cfm) at External Static Pressure (in. wg) |      |      |      |      |      |      |      |      |      |      |      |      |      |      |      |
|-------|------------|-------------|----------|--|------|------|------|------|------|------|------|------|------|------|------|------|------|------|------|
|       |            |             |          | 0  | 0.05 | 0.10 | 0.15 | 0.20 | 0.25 | 0.30 | 0.35 | 0.40 | 0.45 | 0.50 | 0.60 | 0.70 | 0.80 | 0.90 | 1.00 |
| 006   | H          | 6 x 8       | 1/10     | 435  | 425  | 415  | 405  | 390  | 365  | 340  | 325  | 305  | 290  | 275  | 245  | -    | -    | -    | -    |
|       | <b>MH</b>  |             |          | 400  | 390  | 380  | 370  | 355  | 335  | 310  | 295  | 280  | 265  | 255  | 210  | 195  | -    | -    | -    |
|       | ML*        |             |          | 365  | 355  | 345  | 335  | 315  | 300  | 280  | 270  | 255  | 240  | 230  | 195  | -    | -    | -    | -    |
|       | L          |             |          | 320  | 305  | 295  | 280  | 260  | 250  | 235  | 225  | 210  | 195  | 180  | 150  | 135  | -    | -    | -    |
| 009   | H          | 6 x 8       | 1/10     | 435  | 423  | 415  | 405  | 390  | 370  | 340  | 325  | 305  | 290  | 275  | 245  | -    | -    | -    | -    |
|       | <b>MH</b>  |             |          | 400  | 388  | 380  | 370  | 355  | 335  | 310  | 295  | 280  | 265  | 255  | 210  | 195  | -    | -    | -    |
|       | ML*        |             |          | 365  | 353  | 345  | 335  | 315  | 300  | 280  | 270  | 255  | 240  | 230  | 195  | -    | -    | -    | -    |
|       | L          |             |          | 320  | 305  | 295  | 280  | 260  | 250  | 235  | 225  | 210  | 195  | 180  | 150  | 135  | -    | -    | -    |
| 012   | H          | 6 x 8       | 1/10     | 435  | 423  | 415  | 405  | 390  | 370  | 340  | 325  | 305  | 290  | 275  | 245  | -    | -    | -    | -    |
|       | <b>MH</b>  |             |          | 400  | 388  | 380  | 370  | 355  | 335  | 310  | 295  | 280  | 265  | 255  | 210  | 195  | -    | -    | -    |
|       | ML*        |             |          | 365  | 353  | 345  | 335  | 315  | 300  | 280  | 270  | 255  | 240  | 230  | 195  | -    | -    | -    | -    |
|       | L          |             |          | 320  | 305  | 295  | 280  | 260  | 250  | 235  | 225  | 210  | 195  | 180  | 150  | 135  | -    | -    | -    |
| 015   | H          | 9 x 7       | 1/6      | 795  | 775  | 755  | 735  | 715  | 690  | 670  | 600  | 530  | 490  | 455  | 395  | -    | -    | -    | -    |
|       | <b>M</b>   |             |          | 725  | 710  | 695  | 675  | 660  | 640  | 620  | 560  | 495  | 465  | 435  | 375  | -    | -    | -    | -    |
|       | L          |             |          | 620  | 610  | 600  | 590  | 575  | 550  | 525  | 490  | 455  | 395  | 340  | 290  | -    | -    | -    | -    |
| 018   | H          | 9 x 7       | 1/6      | 795  | 775  | 755  | 735  | 715  | 690  | 670  | 600  | 530  | 490  | 455  | 395  | -    | -    | -    | -    |
|       | <b>M</b>   |             |          | 725  | 710  | 695  | 675  | 660  | 640  | 620  | 560  | 495  | 465  | 435  | 375  | -    | -    | -    | -    |
|       | L          |             |          | 620  | 610  | 600  | 590  | 575  | 550  | 525  | 490  | 455  | 395  | 340  | 290  | -    | -    | -    | -    |
| 024   | H          | 9 x 7       | 1/5      | 1035   | 1015 | 995  | 970  | 950  | 925  | 900  | 865  | 835  | 795  | 760  | 685  | 560  | -    | -    | -    |
|       | <b>M</b>   |             |          | 880  | 860  | 845  | 820  | 805  | 785  | 765  | 740  | 720  | 690  | 665  | 590  | 530  | -    | -    | -    |
|       | L          |             |          | 810  | 790  | 775  | 755  | 740  | 725  | 705  | 675  | 650  | 620  | 595  | 510  | -    | -    | -    | -    |
| 030   | H          | 9 x 7       | 1/3      | 1170   | 1145 | 1130 | 1110 | 1080 | 1050 | 1030 | 995  | 965  | 925  | 890  | 815  | 700  | -    | -    | -    |
|       | <b>M</b>   |             |          | 1040   | 1030 | 1020 | 1005 | 990  | 965  | 945  | 915  | 890  | 860  | 830  | 760  | 650  | -    | -    | -    |
|       | L          |             |          | 825  | 820  | 815  | 810  | 805  | 795  | 790  | 775  | 765  | 735  | 705  | 655  | -    | -    | -    | -    |
| 036   | H          | 9 x 7       | 1/2      | 1320   | 1295 | 1275 | 1240 | 1210 | 1185 | 1155 | 1120 | 1085 | 1045 | 1005 | 915  | 805  | 655  | -    | -    |
|       | M          |             |          | 1180   | 1155 | 1140 | 1125 | 1100 | 1075 | 1055 | 1020 | 990  | 955  | 920  | 840  | 725  | 590  | -    | -    |
|       | L          |             |          | 1045   | 1035 | 1025 | 1015 | 1005 | 985  | 970  | 945  | 920  | 890  | 865  | 795  | 690  | -    | -    | -    |
| 042   | H          | 10x10       | 1/2      | 1530   | 1500 | 1475 | 1445 | 1425 | 1380 | 1340 | 1290 | 1240 | 1185 | 1130 | 810  | 715  | 630  | -    | -    |
|       | <b>M</b>   |             |          | 1435   | 1415 | 1395 | 1370 | 1350 | 1325 | 1300 | 1265 | 1235 | 1180 | 1130 | 1040 | 755  | 640  | -    | -    |
|       | L          |             |          | 1160   | 1140 | 1130 | 1120 | 1100 | 1070 | 1050 | 1020 | 990  | 950  | 910  | 831  | 632  | 590  | -    | -    |
| 048   | H          | 10 x 10     | 1/2      | 1845   | 1810 | 1775 | 1740 | 1705 | 1660 | 1615 | 1560 | 1510 | 1455 | 1405 | 1275 | 1080 | -    | -    | -    |
|       | M          |             |          | 1655   | 1620 | 1585 | 1555 | 1535 | 1500 | 1465 | 1415 | 1370 | 1330 | 1290 | 1170 | 970  | -    | -    | -    |
|       | L          |             |          | 1325   | 1315 | 1310 | 1285 | 1265 | 1245 | 1220 | 1180 | 1140 | 1115 | 1090 | 990  | -    | -    | -    | -    |
| 060   | H          | 11 x 10     | 1        | 2345   | 2320 | 2305 | 2285 | 2250 | 2205 | 2180 | 2135 | 2090 | 2060 | 2030 | 1945 | 1850 | 1740 | 1600 | 1465 |
|       | <b>M</b>   |             |          | 2195   | 2170 | 2150 | 2125 | 2105 | 2075 | 2045 | 2005 | 1970 | 1940 | 1915 | 1845 | 1770 | 1630 | 1500 | -    |
|       | L          |             |          | 2045   | 2030 | 2020 | 1995 | 1980 | 1950 | 1925 | 1890 | 1855 | 1825 | 1800 | 1750 | 1640 | 1535 | 1395 | -    |
| 070   | H          | 11 x 10     | 1        | 2505   | 2475 | 2450 | 2410 | 2385 | 2365 | 2340 | 2305 | 2275 | 2250 | 2230 | 2170 | 2070 | 1975 | 1880 | 1765 |
|       | <b>M</b>   |             |          | 2290   | 2265 | 2250 | 2230 | 2200 | 2170 | 2150 | 2135 | 2125 | 2105 | 2085 | 2015 | 1950 | 1865 | 1785 | 1680 |
|       | L          |             |          | 2115   | 2100 | 2085 | 2060 | 2040 | 2020 | 2005 | 1990 | 1975 | 1950 | 1930 | 1875 | 1805 | 1720 | 1655 | 1510 |

10/03/12

Factory settings are in **Bold**

Airflow values are with dry coil and standard filter

For wet coil performance first calculate the face velocity of the air coil (Face Velocity [fpm] = Airflow [cfm] / Face Area [sq ft]).

Then for velocities of 200 fpm reduce the static capability by 0.03 in. wg, 300 fpm by 0.08 in. wg, 400 fpm by 0.12 in. wg. and 500 fpm by 0.16 in. wg.

\* Setting for 265V operation.

## Setting Blower Speed - PSC



**CAUTION: Disconnect all power before performing this operation.**

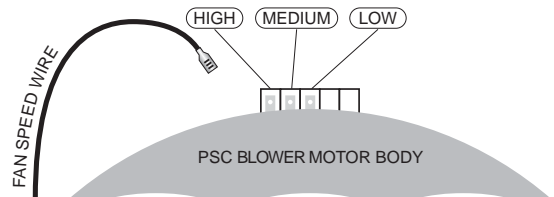

# Blower Performance Data cont.

## 5-Speed ECM Motor

| Model | Motor Spd       | Motor Tap | Blower Size | Motor HP | Airflow (cfm) at External Static Pressure (in. wg) |      |      |      |      |      |      |      |      |      |      |      |      |      |      |      |
|-------|-----------------|-----------|-------------|----------|--|------|------|------|------|------|------|------|------|------|------|------|------|------|------|------|
|       |                 |           |             |          | 0  | 0.05 | 0.10 | 0.15 | 0.20 | 0.25 | 0.30 | 0.35 | 0.40 | 0.45 | 0.50 | 0.60 | 0.70 | 0.80 | 0.90 | 1.00 |
| 015   | High            | 5         | 9 x 7       | 1/2      | 915  | 895  | 880  | 865  | 850  | 830  | 815  | 805  | 795  | 775  | 750  | 730  | 695  | 640  | -    | -    |
|       | <b>Med High</b> | <b>4</b>  |             |          | 805  | 785  | 765  | 750  | 740  | 725  | 705  | 685  | 665  | 655  | 635  | 605  | 535  | -    | -    | -    |
|       | Med             | 3         |             |          | 725  | 715  | 700  | 680  | 660  | 635  | 615  | 600  | 585  | 560  | 535  | 485  | -    | -    | -    | -    |
|       | Med Low         | 2         |             |          | 695  | 675  | 650  | 630  | 610  | 590  | 575  | 550  | 525  | 490  | 455  | -    | -    | -    | -    | -    |
|       | Low             | 1         |             |          | 655  | 600  | 550  | 530  | 508  | 490  | 475  | 435  | 395  | 350  | -    | -    | -    | -    | -    | -    |
| 018   | High            | 5         | 9 x 7       | 1/2      | 915  | 895  | 880  | 865  | 850  | 830  | 815  | 805  | 795  | 775  | 750  | 730  | 695  | 640  | -    | -    |
|       | <b>Med High</b> | <b>4</b>  |             |          | 805  | 785  | 765  | 750  | 740  | 725  | 705  | 685  | 665  | 655  | 635  | 605  | 535  | -    | -    | -    |
|       | Med             | 3         |             |          | 725  | 715  | 700  | 680  | 660  | 635  | 615  | 600  | 585  | 560  | 535  | 485  | -    | -    | -    | -    |
|       | Med Low         | 2         |             |          | 695  | 675  | 650  | 630  | 610  | 590  | 575  | 550  | 525  | 490  | 455  | -    | -    | -    | -    | -    |
|       | Low             | 1         |             |          | 655  | 600  | 550  | 530  | 508  | 490  | 475  | 435  | 395  | 350  | -    | -    | -    | -    | -    | -    |
| 024   | High            | 5         | 9 x 7       | 1/2      | 1000   | 983  | 965  | 950  | 935  | 923  | 910  | 900  | 890  | 873  | 855  | 800  | 825  | -    | -    | -    |
|       | <b>Med High</b> | <b>4</b>  |             |          | 905  | 888  | 870  | 860  | 850  | 833  | 815  | 805  | 795  | 775  | 755  | 740  | 705  | -    | -    | -    |
|       | Med             | 3         |             |          | 855  | 838  | 820  | 800  | 780  | 773  | 765  | 745  | 725  | 715  | 705  | 670  | 580  | -    | -    | -    |
|       | Med Low         | 2         |             |          | 790  | 773  | 755  | 743  | 730  | 710  | 690  | 675  | 660  | 643  | 625  | 570  | -    | -    | -    | -    |
|       | Low             | 1         |             |          | 615  | 600  | 585  | 565  | 545  | 523  | 500  | 468  | 435  | 408  | 380  | -    | -    | -    | -    | -    |
| 030   | High            | 5         | 9 x 7       | 1/2      | 1315   | 1293 | 1270 | 1243 | 1215 | 1183 | 1150 | 1120 | 1090 | 1055 | 1020 | 930  | 845  | -    | -    | -    |
|       | <b>Med High</b> | <b>4</b>  |             |          | 1145   | 1130 | 1115 | 1105 | 1095 | 1080 | 1065 | 1053 | 1040 | 1013 | 985  | 905  | 820  | -    | -    | -    |
|       | Med             | 3         |             |          | 1020   | 1008 | 995  | 978  | 960  | 950  | 940  | 923  | 905  | 895  | 885  | 850  | 795  | 735  | -    | -    |
|       | Med Low         | 2         |             |          | 980  | 963  | 945  | 935  | 925  | 908  | 890  | 878  | 865  | 848  | 830  | 805  | 780  | 720  | -    | -    |
|       | Low             | 1         |             |          | 795  | 778  | 760  | 738  | 715  | 705  | 695  | 678  | 660  | 650  | 640  | 575  | 530  | -    | -    | -    |
| 036   | High            | 5         | 9 x 7       | 1/2      | 1405   | 1380 | 1355 | 1333 | 1310 | 1275 | 1240 | 1208 | 1175 | 1135 | 1095 | 1015 | 895  | 775  | -    | -    |
|       | <b>Med High</b> | <b>4</b>  |             |          | 1275   | 1265 | 1255 | 1245 | 1235 | 1215 | 1195 | 1168 | 1140 | 1105 | 1070 | 985  | 875  | 770  | -    | -    |
|       | Med             | 3         |             |          | 1180   | 1163 | 1145 | 1135 | 1125 | 1110 | 1095 | 1085 | 1075 | 1060 | 1045 | 975  | 865  | 750  | -    | -    |
|       | Med Low         | 2         |             |          | 1125   | 1115 | 1105 | 1090 | 1075 | 1065 | 1055 | 1040 | 1025 | 1008 | 990  | 950  | 855  | 730  | -    | -    |
|       | Low             | 1         |             |          | 835  | 823  | 810  | 793  | 775  | 758  | 740  | 723  | 705  | 690  | 675  | 640  | 570  | -    | -    | -    |
| 042   | High            | 5         | 11 x 10     | 1        | 1805   | 1793 | 1780 | 1770 | 1760 | 1740 | 1720 | 1710 | 1700 | 1688 | 1675 | 1655 | 1635 | 1590 | 1550 | 1475 |
|       | Med High        | 4         |             |          | 1695   | 1688 | 1680 | 1660 | 1640 | 1623 | 1605 | 1593 | 1580 | 1573 | 1565 | 1535 | 1505 | 1460 | 1395 | 1300 |
|       | <b>Med</b>      | <b>3</b>  |             |          | 1605   | 1593 | 1580 | 1560 | 1540 | 1523 | 1505 | 1493 | 1480 | 1470 | 1460 | 1420 | 1380 | 1305 | 1205 | 1135 |
|       | Med Low         | 2         |             |          | 1510   | 1495 | 1480 | 1465 | 1450 | 1435 | 1420 | 1403 | 1385 | 1373 | 1360 | 1310 | 1250 | 1135 | 1055 | 1010 |
|       | Low             | 1         |             |          | 1340   | 1323 | 1305 | 1283 | 1260 | 1245 | 1230 | 1213 | 1195 | 1175 | 1155 | 1040 | 915  | 875  | -    | -    |
| 048   | High            | 5         | 11 x 10     | 1        | 2000   | 1990 | 1980 | 1968 | 1955 | 1940 | 1925 | 1910 | 1915 | 1910 | 1905 | 1880 | 1845 | 1790 | 1655 | 1505 |
|       | Med High        | 4         |             |          | 1840   | 1833 | 1825 | 1810 | 1795 | 1785 | 1775 | 1770 | 1765 | 1755 | 1745 | 1715 | 1670 | 1620 | 1540 | 1360 |
|       | <b>Med</b>      | <b>3</b>  |             |          | 1755   | 1743 | 1730 | 1718 | 1705 | 1698 | 1690 | 1683 | 1675 | 1665 | 1635 | 1600 | 1555 | 1495 | 1435 | 1300 |
|       | Med Low         | 2         |             |          | 1645   | 1630 | 1615 | 1605 | 1595 | 1583 | 1570 | 1560 | 1550 | 1530 | 1510 | 1475 | 1420 | 1350 | 1265 | 1180 |
|       | Low             | 1         |             |          | 1430   | 1413 | 1395 | 1385 | 1375 | 1358 | 1340 | 1320 | 1300 | 1275 | 1250 | 1170 | 1060 | 995  | 930  | 875  |
| 060   | High            | 5         | 11 x 10     | 1        | 2455   | 2440 | 2425 | 2413 | 2400 | 2390 | 2380 | 2365 | 2350 | 2335 | 2320 | 2295 | 2245 | 2175 | 2085 | 2015 |
|       | Med High        | 4         |             |          | 2260   | 2250 | 2240 | 2223 | 2205 | 2195 | 2185 | 2168 | 2150 | 2133 | 2115 | 2085 | 2045 | 2005 | 1975 | 1930 |
|       | <b>Med</b>      | <b>3</b>  |             |          | 2140   | 2123 | 2105 | 2095 | 2085 | 2065 | 2045 | 2033 | 2020 | 2005 | 1990 | 1960 | 1915 | 1870 | 1835 | 1790 |
|       | Med Low         | 2         |             |          | 2010   | 1995 | 1980 | 1963 | 1945 | 1935 | 1925 | 1908 | 1890 | 1873 | 1855 | 1825 | 1780 | 1745 | 1690 | 1645 |
|       | Low             | 1         |             |          | 1815   | 1803 | 1790 | 1775 | 1760 | 1743 | 1725 | 1705 | 1685 | 1665 | 1645 | 1600 | 1565 | 1515 | 1470 | 1410 |
| 070   | High            | 5         | 11 x 10     | 1        | 2500   | 2495 | 2490 | 2473 | 2455 | 2438 | 2420 | 2405 | 2390 | 2363 | 2335 | 2325 | 2280 | 2215 | 2120 | 1995 |
|       | Med High        | 4         |             |          | 2300   | 2295 | 2290 | 2270 | 2250 | 2233 | 2215 | 2200 | 2185 | 2168 | 2150 | 2115 | 2080 | 2040 | 1990 | 1915 |
|       | <b>Med</b>      | <b>3</b>  |             |          | 2175   | 2163 | 2150 | 2138 | 2125 | 2100 | 2075 | 2060 | 2045 | 2030 | 2015 | 1980 | 1945 | 1905 | 1860 | 1820 |
|       | Med Low         | 2         |             |          | 2040   | 2028 | 2015 | 2000 | 1985 | 1965 | 1945 | 1930 | 1915 | 1898 | 1880 | 1850 | 1805 | 1760 | 1725 | 1685 |
|       | Low             | 1         |             |          | 1850   | 1833 | 1815 | 1800 | 1785 | 1765 | 1745 | 1728 | 1710 | 1683 | 1655 | 1615 | 1580 | 1530 | 1475 | 1300 |

09/26/12

Factory settings are in Bold  
Airflow values are with dry coil and standard 1 in. filter

### 5-Speed ECM Motor Connections

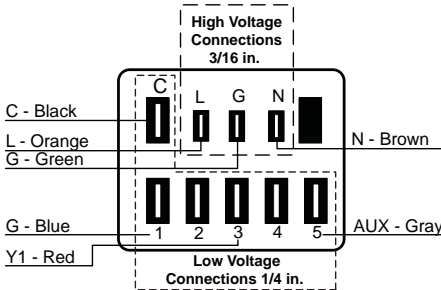

## 5-Speed ECM Constant Torque Motors

The 5-speed ECM is a 'Constant Torque' ECM motor and delivers air flow similar to a PSC but operates as efficiently as an variable speed ECM Motor. Because it's an ECM Motor, the 5-speed ECM can ramp slowly up or down like the variable speed ECM Motor. There are 5 possible speed taps available on the 5-speed ECM motor with #1 being the lowest airflow and #5 being the highest airflow. These speed selections are preset at the time of manufacture and are easily changed in the field if necessary.

### 5-Speed ECM Benefits:

- High efficiency
- Soft start
- 5 speeds with up to 4 speeds on-line
- Built in logic allows air flow to change with G, Y1, Y2 and W signals
- Super efficient low airflow continuous blower setting (G)

If more than one tap are energized at the same time, built in logic gives precedence to the highest tap number and allows air flow to change with G, Y1, Y2 and W signals. Each of those 5 speeds has a specific 'Torque' value programmed into the motor for each speed selection. As static pressure increases, airflow decreases resulting in less torque on the rotor. The motor responds only to changes in torque and adjusts its speed accordingly.

The 5-speed ECM motor is powered by line voltage but the motor speed is energized by 24VAC.

Power Connection - 3/16 in. quick connects - Line 1 (orange wire) to L, Ground (green wire) to G, Line 2 (for 208V-230V units) to N (brown wire).

Signal Connection - 1/4 in. quick connects - Common to C, 24VAC to Taps #1-5.

Applying 24VAC power between any of the motor taps 1-5 (1/4 in. quick connects) and common will signal the motor to run and regulate torque at the programmed level. The tap input voltage must be in the range 12-33VAC. The 5-speed ECM will have less variation over the operating static pressure range versus a PSC motor as well as a significant watts reduction due to the high motor efficiency.

Thermal Protection - Motor is electronically protected.

Locked Rotor Amps - If motor speed decreases below a programmed stall speed, the motor will shut down and after a delay period, the control will attempt to restart the motor.

The 5-speed ECM speed tap selections are as follows:

The blue wire should be placed on the speed tap desired for the (G) continuous blower setting – factory wired to Tap 1.

The red wire should be placed on the speed tap desired during compressor operation (Y1 signal) – factory wired to Tap 3 or 4.

The gray wire is not factory wired to the motor and is tied to the wire harness. It is field connected and can be used with 3ht/2cl thermostats or IntelliZone to deliver the required air flow for the Y2 signal.

The tan wire should be placed on the speed tap desired for auxiliary heat (W signal) – factory wired to Tap 5.

# Blower Performance Data cont.

## Variable Speed ECM Motor

| Model | Max ESP | Blower Size | Motor hp | Air Flow Dip Switch Settings |          |           |          |           |           |           |           |           |      |           |      |
|-------|---------|-------------|----------|------------------------------|----------|-----------|----------|-----------|-----------|-----------|-----------|-----------|------|-----------|------|
|       |         |             |          | 1                            | 2        | 3         | 4        | 5         | 6         | 7         | 8         | 9         | 10   | 11        | 12   |
| 015   | 0.50    | 9 x 7       | 1/2      | 300                          | 400<br>L | 500       | 600<br>M | 700<br>H  | 800       |           |           |           |      |           |      |
| 018   | 0.50    | 9 x 7       | 1/2      | 300                          | 400<br>L | 500       | 600<br>M | 700<br>H  | 800       |           |           |           |      |           |      |
| 024   | 0.50    | 9 x 7       | 1/2      |                              | 400<br>L | 500       | 600<br>M | 700<br>H  | 800       | 900       | 1000      | 1100      |      |           |      |
| 030   | 0.50    | 9 x 7       | 1/2      |                              | 400      | 500<br>L  | 600      | 700<br>M  | 800       | 900       | 1000<br>H | 1100      |      |           |      |
| 036   | 0.50    | 9 x 7       | 1/2      |                              | 400      | 500       | 600<br>L | 700       | 800       | 900<br>M  | 1000      | 1100<br>H | 1200 |           |      |
| 042   | 0.50    | 11 x 10     | 1/2      | 500                          | 600      | 700<br>L  | 875      | 1050      | 1150<br>M | 1250      | 1325      | 1375<br>H | 1475 | 1550      |      |
| 048   | 0.50    | 11 x 10     | 1/2      | 500                          | 600      | 700       | 875<br>L | 1050      | 1150      | 1250      | 1325<br>M | 1375<br>H | 1475 | 1550<br>H | 1600 |
| 060   | 0.75    | 11 x 10     | 1        | 600                          | 800      | 1000<br>L | 1300     | 1500<br>M | 1750      | 1950<br>H | 2100      | 2200      | 2300 |           |      |
| 070   | 0.75    | 11 x 10     | 1        | 600                          | 800      | 1000<br>L | 1300     | 1500<br>M | 1750      | 1950      | 2100<br>H | 2200      | 2300 |           |      |

Factory settings are at recommended L-M-H DIP switch locations. Shaded regions are recommended for best performance. It is acceptable to operate outside of this area as long as the WSHP operates within the guidelines of the Operating Limits table and Correction Factor tables. Lowest and Highest DIP switch settings are assumed to be L and H respectively. CFM is controlled within ±5% up to the maximum esp. Max esp includes allowance for wet coil and standard filter

09/26/12

## Setting Blower Speed - Variable Speed ECM

Variable speed ECM blower motors have 12 selectable speeds and are factory set for optimum performance. To change speeds on an FX10 control, use the Medium User Interface (MUI) to enter the MAINT menu to adjust the 12 soft switches. When applicable, the speed settings may also be adjusted through the Building Automation System (BAS).



**CAUTION: Disconnect all power before performing this operation.**

## Blower Performance Data cont.

### Setting Blower Speed - Variable Speed ECM

The ABC board's Yellow Config LED will flash the current variable speed ECM blower speed selections for low, med, and high continuously with a short pause in between. The speeds can also be confirmed with the AID Tool under the Setup/ECM Setup screen. The variable speed ECM blower motor speeds can be field adjusted with or without using an AID Tool.

### Variable Speed ECM Setup without an AID Tool

The blower speeds for Low (G only), Med (Y1), and High (Y2/Aux) can be adjusted directly at the Aurora ABC board which utilizes the push button (SW1) on the ABC board. This procedure is outlined in the Variable Speed ECM Configuration Mode portion of the Aurora 'Base' Control System section.

### Variable Speed ECM Setup with an AID Tool

A much easier method utilizes the AID Tool to change the airflow using the procedure below. First navigate to the Setup screen and then select ECM Setup. This screen displays the current variable speed ECM settings. It allows the technician to enter the setup screens to change the variable speed ECM settings. Change the highlighted item using the ◀ and ▶ buttons and then press the ◻ button to select the item.

### Variable Speed ECM Setup with an AID Tool cont.

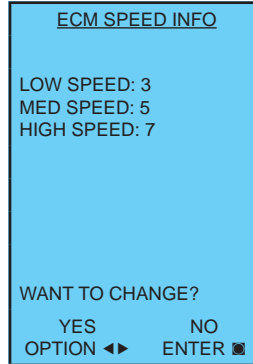

Selecting YES will enter variable speed ECM speed setup, while selecting NO will return to the previous screen.

Variable Speed ECM Speed Setup - These screens allow the technician to select the low, medium, and high blower speed for the variable speed ECM blower motor. Change the highlighted item using the ▲ and ▼ buttons. Press the ◻ button to select the speed.

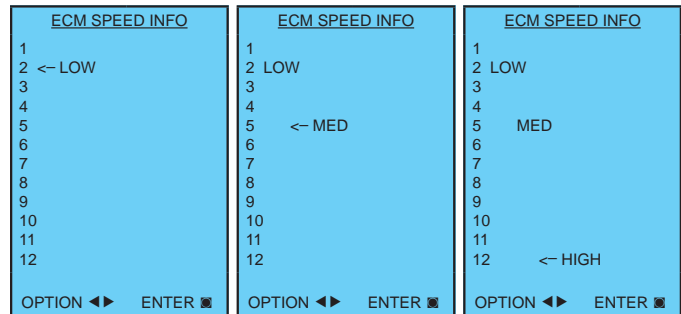

After the high speed setting is selected the AID Tool will automatically transfer back to the ECM Setup screen.



# Wiring Schematics

## Aurora Base Control 208-230/60/1 PSC

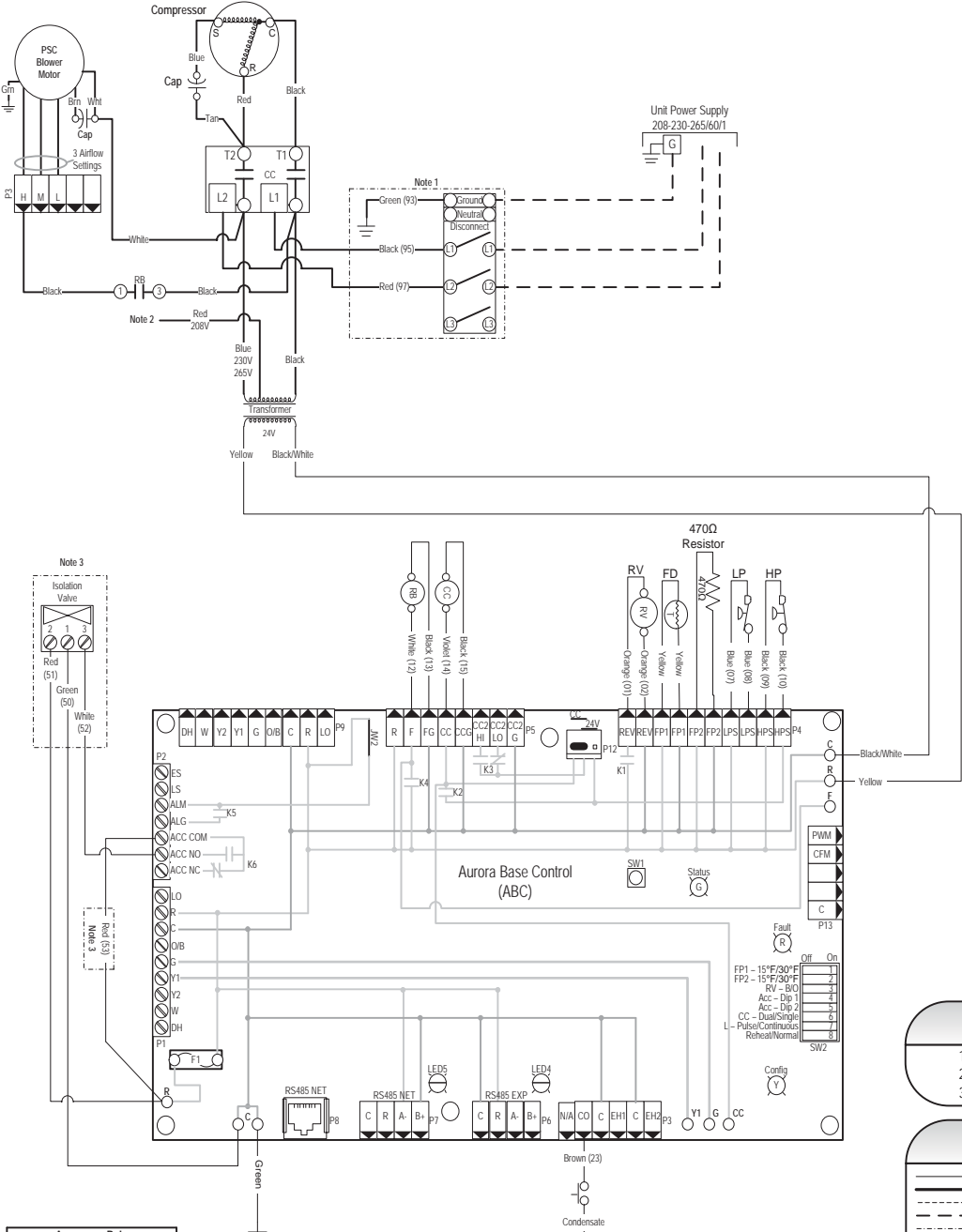

- Notes:**
- 1 - Optional, factory installed unit mounted disconnect.
  - 2 - Swap blue and red leads for 208V operation.
  - 3 - Optional, factory installed internal isolation valve.

**Legend**

|  |                             |  |                               |
|--|-----------------------------|--|-------------------------------|
|  | Factory Low Voltage Wiring  |  | Thermistor                    |
|  | Factory Low Voltage Wiring  |  | Relay Coil                    |
|  | Field Low Voltage Wiring    |  | Switch - Condensate Overflow  |
|  | Field Low Voltage Wiring    |  | Switch - High pressure        |
|  | Optional Block              |  | Switch - Low pressure         |
|  | DC Voltage PCB Traces       |  | Polarized connector           |
|  | Field Zone Sensor Wiring    |  | Ground                        |
|  | Internal Junction           |  | Relay Contacts - N.O., N.C.   |
|  | Quick Connect Terminal      |  | Capacitor                     |
|  | Field Wiring Lug            |  | Fuse                          |
|  | Ground                      |  | Light Emitting Diode - Green  |
|  | Relay Contacts - N.O., N.C. |  | Light Emitting Diode - Yellow |
|  | Capacitor                   |  | Light Emitting Diode - Red    |
|  | Fuse                        |  |                               |

CC - Compressor Contactor  
 CO - Condensate Overflow Sensor  
 ES - Emergency Shutdown  
 HP - High Pressure Switch  
 LP - Low Pressure Switch  
 FD - Freeze Detection Sensor  
 F1 - Fuse

SW1 - Push button  
 SW2 - DIP package 8 position  
 RB - Blower Relay  
 RV - Reversing Valve Coil

**Accessory Relay**

| Operation             | SW2-4 | SW2-5 |
|-----------------------|-------|-------|
| Cycle with Blower     | On    | On    |
| Cycle with Compressor | Off   | Off   |
| Water Valve Slow Open | On    | Off   |
| Outdoor Air Dampers   | Off   | On    |

**Aurora Timing Events**

| Event  | Normal Mode        | Test Mode          |
|--|--------------------|--------------------|
| Random Start Delay                                 | 5 to 30 seconds    | 1 second           |
| Compressor On Delay                                | 5 seconds          | < 1 second         |
| Compressor Minimum On Time                         | 2 minutes          | 5 seconds          |
| Compressor Short Cycle Delay                       | 4 minutes          | 15 seconds         |
| Blower Off Delay                                   | 30 seconds         | 2 seconds          |
| Fault Recognition Delay - High Pressure            | Less than 1 second | Less than 1 second |
| Start-Up Bypass - Low Pressure                     | 2 minutes          | 30 seconds         |
| Fault Recognition Delay - Low Pressure             | 30 seconds         | 30 seconds         |
| Start-Up Bypass - Low Water/Air Coil Limit         | 2 minutes          | 30 seconds         |
| Fault Recognition Delay - Low Water/Air Coil Limit | 30 seconds         | 30 seconds         |
| Fault Recognition Delay - Condensate Overflow      | 30 seconds         | 30 seconds         |
| Thermostat Call Recognition Time                   | 2 seconds          | 2 seconds          |
| Auxiliary Heat Staging Delay                       | 5 minutes          | 20 seconds         |
| Emergency Heat Staging Delay                       | 2 minutes          | 7.5 seconds        |
| Water Valve Slow Open Delay                        | 30 seconds         | 30 seconds         |
| Reheat Delay                                       | 30 seconds         | 30 seconds         |

**Aurora LED Flash Codes**

| Flash Code                       | Random Start Delay  | Status LED (LED1, Green)         | Configuration LED (LED2, Yellow) | Fault LED (LED3, Red)              |               |
|----------------------------------|---|----------------------------------|----------------------------------|------------------------------------|---------------|
| <b>Slow Flash</b>                | 1 second on and 1 second off  |                                  |                                  |                                    |               |
| <b>Fast Flash</b>                | 100 milliseconds on and 400 milliseconds off  |                                  |                                  |                                    |               |
| <b>Flash Code</b>                | 100 milliseconds on and 400 milliseconds off with a 2 second pause before repeating |                                  |                                  |                                    |               |
| Status LED (LED1, Green)         | Fast Flash  |                                  |                                  |                                    |               |
| Configuration LED (LED2, Yellow) | Fast Flash  |                                  |                                  |                                    |               |
| Fault LED (LED3, Red)            | Fast Flash  |                                  |                                  |                                    |               |
| Status LED (LED1, Green)         |   | Configuration LED (LED2, Yellow) |                                  | Fault LED (LED3, Red)              |               |
| Normal Mode                      | ON  | No Software Override             | Flash ECM Setting                | Normal Mode                        | OFF           |
| Control is Non-Functional        | OFF   | DIP Switch Override              | Slow Flash                       | Input Fault Lockout                | Flash Code 1  |
| Test Mode                        | Slow Flash  | ECM Configure Mode               | Fast Flash                       | High Pressure Lockout              | Flash Code 2  |
| Lockout Active                   | Fast Flash  | Reset Configure Mode             | Off                              | Low Pressure Lockout               | Flash Code 3  |
| Dehumidification Mode            | Flash Code 3  |                                  |                                  | Low Air Coil Limit Lockout - FP2   | Flash Code 4  |
| Reserved                         | Flash Code 3  |                                  |                                  | Low Water Coil Limit Lockout - FP1 | Flash Code 5  |
| Reserved                         | Flash Code 4  |                                  |                                  | Reserved                           | Flash Code 6  |
| Load Shed                        | Flash Code 5  |                                  |                                  | Condensate Overflow Lockout        | Flash Code 7  |
| ESD                              | Flash Code 6  |                                  |                                  | Over/Under Voltage Shutdown        | Flash Code 8  |
| Reserved                         | Flash Code 7  |                                  |                                  | Reserved                           | Flash Code 9  |
|                                  |   |                                  |                                  | Reserved                           | Flash Code 10 |
|                                  |   |                                  |                                  | Air/Water Coil Limit Sensor Error  | Flash Code 11 |

# Wiring Schematics cont.

## Aurora Base Control 460/60/3 Variable Speed ECM

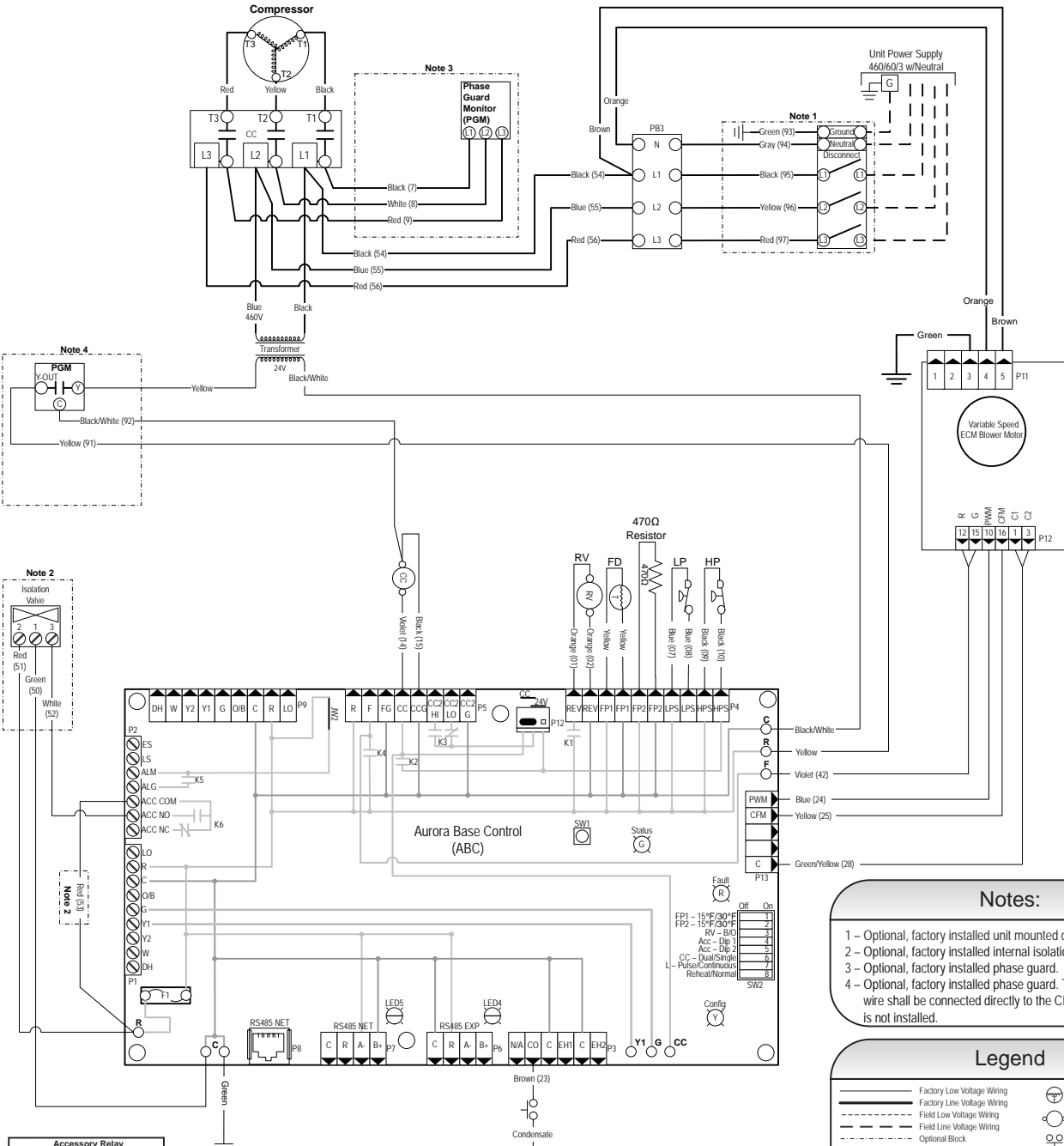

- Notes:**
- 1 - Optional, factory installed unit mounted disconnect.
  - 2 - Optional, factory installed internal isolation valve.
  - 3 - Optional, factory installed phase guard.
  - 4 - Optional, factory installed phase guard. The yellow transformer wire shall be connected directly to the CPU board, if this option is not installed.

**Legend**

|  |                             |  |                               |
|--|-----------------------------|--|-------------------------------|
|  | Factory Low Voltage Wiring  |  | Thermistor                    |
|  | Factory Line Voltage Wiring |  | Relay Coil                    |
|  | Field Low Voltage Wiring    |  | Switch - Condensate Overflow  |
|  | Field Line Voltage Wiring   |  | Switch - High pressure        |
|  | Optional Block              |  | Switch - Low pressure         |
|  | DC Voltage PCB Traces       |  | Polarized connector           |
|  | Field Zone Sensor Wiring    |  | Light Emitting Diode - Green  |
|  | Internal Junction           |  | Light Emitting Diode - Yellow |
|  | Quick Connect Terminal      |  | Light Emitting Diode - Red    |
|  | Field Wiring Lug            |  | SW1 - Push button             |
|  | Ground                      |  | SW2 - DIP package 8 position  |
|  | Relay Contacts - N.O., N.C. |  | RV - High Pressure Switch     |
|  | Capacitor                   |  | LP - Low Pressure Switch      |
|  | Fuse                        |  | FD - Freeze Detection Sensor  |
|  |                             |  | F1 - Fuse                     |

CC - Compressor Contactor  
 CO - Condensate Overflow Sensor  
 ES - Emergency Shutdown  
 ALG - Alarm  
 ACC COM - Accessory Compressor  
 ACC NO - Accessory Compressor Normally Open  
 ACC NC - Accessory Compressor Normally Closed  
 LO - Lockout  
 C - Common  
 R - Run  
 F - Fault  
 FG - Field Guard  
 CC2 - Compressor Control 2  
 HI - High Pressure  
 LO - Low Pressure  
 G - Ground  
 P5 - Power 5  
 REV - Reverse  
 REV1 - Reverse 1  
 FP1 - Field Pressure 1  
 FP2 - Field Pressure 2  
 LPS - Low Pressure Switch  
 LPS1 - Low Pressure Switch 1  
 LPS2 - Low Pressure Switch 2  
 P4 - Power 4  
 SW2 - DIP package 8 position  
 Config - Configuration  
 Y - Yellow  
 G - Green  
 B - Blue  
 W - White  
 R - Red  
 CC - Compressor Control  
 L - Pulse/Continuous Reheat/Normal

| Accessory Relay       |       |       |
|-----------------------|-------|-------|
| Operation             | SW2-4 | SW2-5 |
| Cycle with Blower     | On    | On    |
| Cycle with Compressor | Off   | Off   |
| Water Valve Slow Open | On    | Off   |
| Outdoor Air Damper    | Off   | On    |

| Aurora Timing Events                               |                    |                    |
|--|--------------------|--------------------|
| Event  | Normal Mode        | Test Mode          |
| Random Start Delay                                 | 5 to 80 seconds    | 1 second           |
| Compressor On Delay                                | 5 seconds          | < 1 second         |
| Compressor Minimum On Time                         | 2 minutes          | 5 seconds          |
| Compressor Start Cycle Delay                       | 4 minutes          | 15 seconds         |
| Blower Off Delay                                   | 30 seconds         | 2 seconds          |
| Fault Recognition Delay - High Pressure            | Less than 1 second | Less than 1 second |
| Start-Up Bypass - Low Pressure                     | 2 minutes          | 30 seconds         |
| Fault Recognition Delay - Low Pressure             | 30 seconds         | 30 seconds         |
| Start-Up Bypass - Low Water/Air Coil Limit         | 2 minutes          | 30 seconds         |
| Fault Recognition Delay - Low Water/Air Coil Limit | 30 seconds         | 30 seconds         |
| Fault Recognition Delay - Condensate Overflow      | 30 seconds         | 30 seconds         |
| Thermostat Call Recognition Time                   | 2 seconds          | 2 seconds          |
| Auxiliary Heat Staging Delay                       | 5 minutes          | 20 seconds         |
| Emergency Heat Staging Delay                       | 2 minutes          | 7.5 seconds        |
| Water Valve Slow Open Delay                        | 90 seconds         | 90 seconds         |
| Reheat Delay                                       | 30 seconds         | 30 seconds         |

| Aurora LED Flash Codes           |   |                                  |                       |                                    |               |
|----------------------------------|---|----------------------------------|-----------------------|------------------------------------|---------------|
| Slow Flash                       | 1 second on and 1 second off  |                                  |                       |                                    |               |
| Fast Flash                       | 100 milliseconds on and 100 milliseconds off  |                                  |                       |                                    |               |
| Flash Code                       | 100 milliseconds on and 400 milliseconds off with a 2 second pause before repeating |                                  |                       |                                    |               |
| Random Start Delay               |   |                                  |                       |                                    |               |
| Status LED (LED1, Green)         | Fast Flash  |                                  |                       |                                    |               |
| Configuration LED (LED2, Yellow) | Fast Flash  |                                  |                       |                                    |               |
| Fault LED (LED3, Red)            | Fast Flash  |                                  |                       |                                    |               |
| Status LED (LED1, Green)         |   | Configuration LED (LED2, Yellow) | Fault LED (LED3, Red) |                                    |               |
| Normal Mode                      | ON  | No Software Override             | Flash ECM Setting     | Normal Mode                        | OFF           |
| Control is Non-Functional        | OFF   | DIP Switch Override              | Slow Flash            | Input Fault Lockout                | Flash Code 1  |
| Reserved                         | Slow Flash  | ECM Configure Mode               | Fast Flash            | High Pressure Lockout              | Flash Code 2  |
| Lockout Active                   | Fast Flash  | Reset Configure Mode             | Off                   | Low Pressure Lockout               | Flash Code 3  |
| Dehumidification Mode            | Flash Code 2  |                                  |                       | Low Air Coil Limit Lockout - FP2   | Flash Code 4  |
| Reserved                         | Flash Code 3  |                                  |                       | Low Water Coil Limit Lockout - FP1 | Flash Code 5  |
| Reserved                         | Flash Code 4  |                                  |                       | Reserved                           | Flash Code 6  |
| Load Shed                        | Flash Code 5  |                                  |                       | Condensate Overflow Lockout        | Flash Code 7  |
| ESD                              | Flash Code 6  |                                  |                       | Over/Under Voltage Shutdown        | Flash Code 8  |
| Reserved                         | Flash Code 7  |                                  |                       | Reserved                           | Flash Code 9  |
|                                  |   |                                  |                       | Reserved                           | Flash Code 10 |
|                                  |   |                                  |                       | Air/Water Coil Limit Sensor Error  | Flash Code 11 |

# Wiring Schematics cont.

## Aurora Base Control 460/60/3 5-Speed ECM

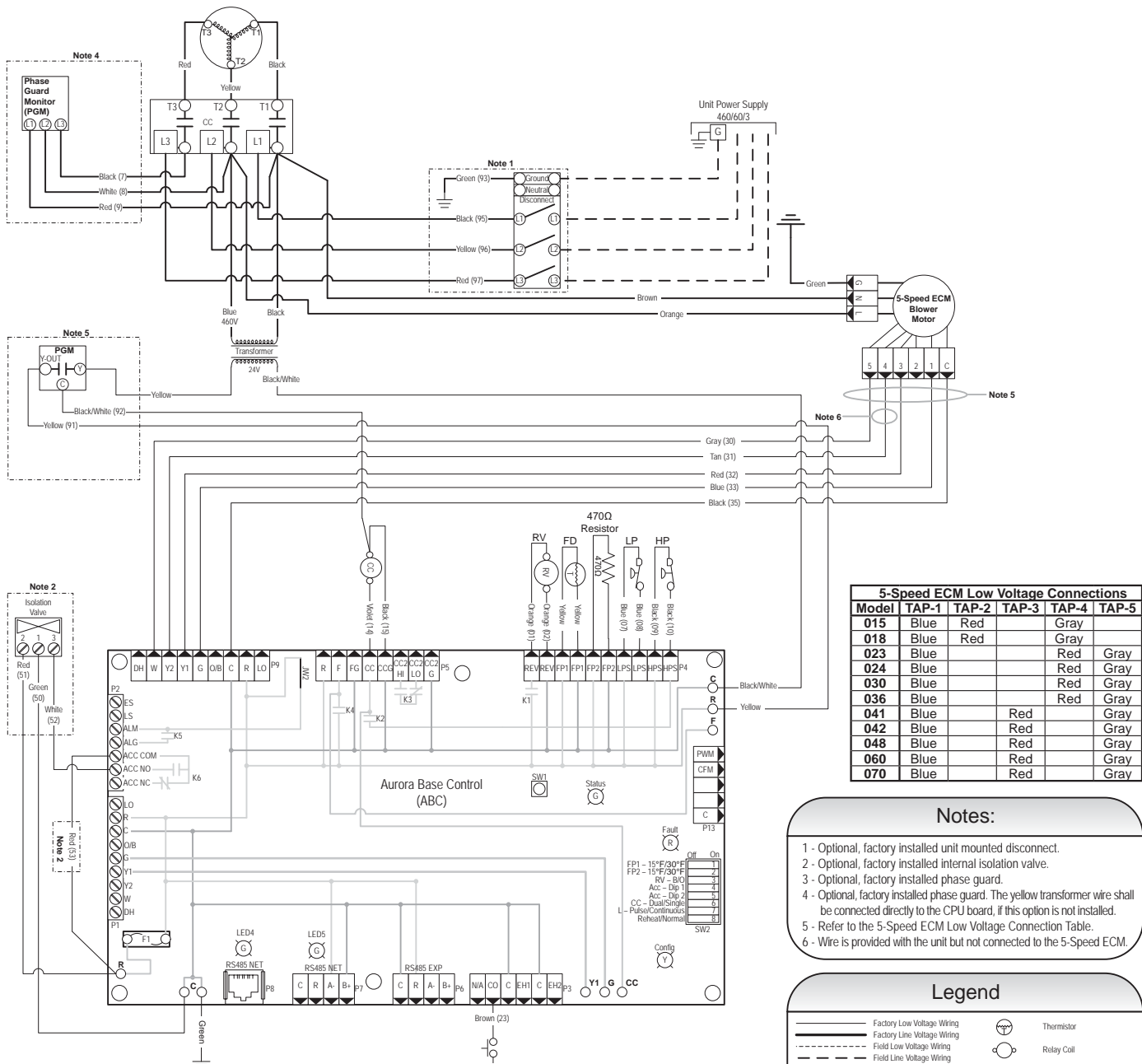

| Model | TAP-1 | TAP-2 | TAP-3 | TAP-4 | TAP-5 |
|-------|-------|-------|-------|-------|-------|
| 015   | Blue  | Red   |       | Gray  |       |
| 023   | Blue  | Red   |       | Gray  |       |
| 024   | Blue  |       |       | Red   | Gray  |
| 030   | Blue  |       |       | Red   | Gray  |
| 036   | Blue  |       |       | Red   | Gray  |
| 041   | Blue  |       | Red   |       | Gray  |
| 042   | Blue  |       | Red   |       | Gray  |
| 048   | Blue  |       | Red   |       | Gray  |
| 060   | Blue  |       | Red   |       | Gray  |
| 070   | Blue  |       | Red   |       | Gray  |

### Notes:

- 1 - Optional, factory installed unit mounted disconnect.
- 2 - Optional, factory installed internal isolation valve.
- 3 - Optional, factory installed phase guard.
- 4 - Optional, factory installed phase guard. The yellow transformer wire shall be connected directly to the CPU board, if this option is not installed.
- 5 - Refer to the 5-Speed ECM Low Voltage Connection Table.
- 6 - Wire is provided with the unit but not connected to the 5-Speed ECM.

### Legend

|  |                                 |  |                                 |
|--|---------------------------------|--|---------------------------------|
|  | Factory Low Voltage Wiring      |  | Thermistor                      |
|  | Factory Line Voltage Wiring     |  | Relay Coil                      |
|  | Field Low Voltage Wiring        |  | Switch - Condensate Overflow    |
|  | Field Line Voltage Wiring       |  | Switch - High pressure          |
|  | Optional Block                  |  | Switch - Low pressure           |
|  | DC Voltage PCB Traces           |  | Polarized connector             |
|  | Field Zone Sensor Wiring        |  | Light Emitting Diode - Green    |
|  | Internal Junction               |  | Light Emitting Diode - Yellow   |
|  | Quick Connect Terminal          |  | Light Emitting Diode - Red      |
|  | Field Wiring Lug                |  | Relay Contacts - N.O., N.C.     |
|  | Ground                          |  | Capacitor                       |
|  | Relay Contacts - N.O., N.C.     |  | Fuse                            |
|  | Capacitor                       |  | CC - Compressor Contactor       |
|  | Fuse                            |  | CO - Condensate Overflow Sensor |
|  | CC - Compressor Contactor       |  | ES - Emergency Shutdown         |
|  | CO - Condensate Overflow Sensor |  | HP - High Pressure Switch       |
|  | ES - Emergency Shutdown         |  | LP - Low Pressure Switch        |
|  | HP - High Pressure Switch       |  | FD - Freeze Detection Sensor    |
|  | LP - Low Pressure Switch        |  | PGM - Phase Guard Monitor       |
|  | FD - Freeze Detection Sensor    |  | RH - Reheat Valve Coil          |
|  | PGM - Phase Guard Monitor       |  | SW1 - Push button               |
|  | RH - Reheat Valve Coil          |  | SW2 - DIP package 8 position    |

| Operation             | SW2-4 | SW2-5 |
|-----------------------|-------|-------|
| Cycle with Blower     | On    | On    |
| Cycle with Compressor | Off   | Off   |
| Water Valve Slow Open | On    | Off   |
| Outdoor Air Bumper    | Off   | On    |

| Event  | Normal Mode        | Test Mode          |
|--|--------------------|--------------------|
| Random Start Delay                                 | 3 to 80 seconds    | 1 second           |
| Compressor On Delay                                | 5 seconds          | < 1 second         |
| Compressor Minimum On Time                         | 2 minutes          | 5 seconds          |
| Compressor Short Cycle Delay                       | 4 minutes          | 15 seconds         |
| Blower Off Delay                                   | 30 seconds         | 2 seconds          |
| Fault Recognition Delay - High Pressure            | Less than 1 second | Less than 1 second |
| Start-Up Bypass - Low Pressure                     | 2 minutes          | 30 seconds         |
| Fault Recognition Delay - Low Pressure             | 30 seconds         | 30 seconds         |
| Start-Up Bypass - Low Water/Air Coil Limit         | 2 minutes          | 30 seconds         |
| Fault Recognition Delay - Low Water/Air Coil Limit | 30 seconds         | 30 seconds         |
| Fault Recognition Delay - Condensate Overflow      | 30 seconds         | 30 seconds         |
| Thermostat Call Recognition Time                   | 2 seconds          | 2 seconds          |
| Auxiliary Heat Staging Delay                       | 5 minutes          | 20 seconds         |
| Emergency Heat Staging Delay                       | 2 minutes          | 7.5 seconds        |
| Water Valve Slow Open Delay                        | 90 seconds         | 90 seconds         |
| Reheat Delay                                       | 30 seconds         | 30 seconds         |

| Flash Code                         | Meaning   |
|------------------------------------|---|
| <b>Slow Flash</b>                  | 1 second on and 1 second off  |
| <b>Fast Flash</b>                  | 100 milliseconds on and 100 milliseconds off  |
| <b>Flash Code</b>                  | 100 milliseconds on and 400 milliseconds off with a 2 second pause before repeating |
| Random Start Delay                 |   |
| Status LED (LED1, Green)           | Fast Flash  |
| Configuration LED (LED2, Yellow)   | Fast Flash  |
| Fault LED (LED3, Red)              | Fast Flash  |
| Status LED (LED1, Green)           |   |
| Normal Mode                        | ON  |
| Control is Non-Functional          | OFF   |
| Test Mode                          | Slow Flash  |
| Lockout Active                     | Fast Flash  |
| Dehumidification Mode              | Flash Code 2  |
| Reserved                           | Flash Code 3  |
| Reserved                           | Flash Code 4  |
| Load Shed                          | Flash Code 5  |
| ESD                                | Flash Code 6  |
| Reserved                           | Flash Code 7  |
| Configuration LED (LED2, Yellow)   |   |
| No Software Override               | Flash ECM Setting   |
| DIP Switch Override                | Slow Flash  |
| ECM Configure Mode                 | Fast Flash  |
| Reset Configure Mode               | OFF   |
| Fault LED (LED3, Red)              |   |
| Normal Mode                        | OFF   |
| Input Fault Lockout                | Flash Code 1  |
| High Pressure Lockout              | Flash Code 2  |
| Low Pressure Lockout               | Flash Code 3  |
| Low Air Coil Limit Lockout - FP2   | Flash Code 4  |
| Low Water Coil Limit Lockout - FP1 | Flash Code 5  |
| Reserved                           | Flash Code 6  |
| Condensate Overflow Lockout        | Flash Code 7  |
| Over/Under Voltage Shutdown        | Flash Code 8  |
| Reserved                           | Flash Code 9  |
| Reserved                           | Flash Code 10   |
| Air/Water Coil Limit Sensor Error  | Flash Code 11   |







# Controls - Aurora Base Control

## Aurora ‘Base’ Control



**NOTE:** Refer to the Aurora Base Control Application and Troubleshooting Guide and the Instruction Guide: Aurora Interface and Diagnostics (AID) Tool for additional information.

### Control Features

Software ABC Standard Version 2.0

#### Single or Dual Capacity Compressors

Either single or dual capacity compressors can be operated.

#### ECM Blower Motor Option

An ECM blower motor can be driven directly using the onboard PWM output. Four blower speeds are available based upon the G, Y1, Y2, and W input signals to the board. The blower speeds can be changed either by the ECM manual configurations mode method or by using the Aurora AID Tool directly. All four blower speeds can be set to the same speed if desired.

#### 5-Speed ECM Blower Motor Option

A 5-Speed ECM blower motor will be driven directly using the thermostat connections. Any of the G, Y1, or Y2/W signals can drive any of the 5 available pre-programmed blower speeds on the motor.

### Other Control Features

- Random start at power up
- Anti-short cycle protection
- High and low pressure cutouts
- Loss of charge
- Water coil freeze detection
- Air coil freeze detection
- Over/under voltage protection
- Condensate overflow sensor
- Load shed
- Dehumidification (where applicable)
- Emergency shutdown
- Hot gas reheat operation (where applicable)
- Diagnostic LED
- Test mode push button switch
- Two auxiliary electric heat outputs
- Alarm output
- Accessory output with N.O. and N.C.
- Modbus communication (master)
- Modbus communication (slave)

## Field Selectable Options via Hardware

**DIP Switch (SW1)** – Test/Configuration Button (See SW1 Operation Table)

### Test Mode

The control is placed in the test mode by holding the push button switch SW1 for 2 - 5 seconds. In test mode most of the control timings will be shortened by a factor of sixteen (16). LED3 (green) will flash at 1 second on and 1 second off. Additionally, when entering test mode LED1 (red) will flash the last lockout one time. Test mode will automatically time out after 30 minutes. Test mode can be exited by pressing and holding the SW1 button for 2 to 5 seconds or by cycling the power. **NOTE:** Test mode will automatically be exited after 30 minutes.

### ECM Configuration Mode

The control is placed in the ECM configuration mode by holding the pushbutton switch SW1 for 5 to 10 seconds, the high, low, and “G” ECM speeds can be selected by following the LED display lights. LED2 (yellow) will fast flash when entering the ECM configuration. When setting “G” speed LED3 (green) will be continuously lit, for low speed LED1 (red) will be continuously lit, and for high speed both LED3 (green) and LED1 (red) will be continuously lit. During the ECM configuration mode LED2 (yellow) will flash each of the 12 possible blower speeds 3 times. When the desired speed is flashed press SW1, LED2 will fast flash until SW1 is released. “G” speed has now been selected. Next select low speed, and high speed blower selections following the same process above. After third selection has been made, the control will exit the ECM configuration mode. Aux fan speed will remain at default or current setting and requires the AID Tool for adjustment.

### Reset Configuration Mode

The control is placed in reset configuration mode by holding the push button switch SW1 for 50 to 60 seconds. This will reset all configuration settings and the EEPROM back to the factory default settings. LED3 (green) will turn off when entering reset configuration mode. Once LED3 (green) turns off, release SW1 and the control will reset.

### DIP Switch (SW2)

- SW2-1** FP1 Selection – Low water coil temperature limit setting for freeze detection. On = 30°F; Off = 15°F.
- SW2-2** FP2 Selection – On = 30°F; Off = N/A
- SW2-3** RV – O/B - thermostat type. Heat pump thermostats with “O” output in cooling or “B” output in Heating can be selected. On = O; Off = B.
- SW2-4** Access Relay Operation (P2)

| Access Relay Operation          | SW2-4 | SW2-5 |
|---------------------------------|-------|-------|
| Cycle with Blower               | ON    | ON    |
| Cycle with Compressor           | OFF   | OFF   |
| Water Valve Slow Opening        | ON    | OFF   |
| Cycle with Comm. T-stat Hum Cmd | OFF   | ON    |

## Controls - Aurora Base Control cont.

**Cycle with Blower** - The accessory relay will cycle with the blower output.

**Cycle with Compressor** - The accessory relay will cycle with the compressor output.

**Water Valve Slow Opening** - The accessory relay will cycle and delay both the blower and compressor output for 90 seconds.

- SW2-6** CC Operation – selection of single or dual capacity compressor. On = Single Stage; Off = Dual Capacity
- SW2-7** Lockout and Alarm Outputs (P2) – selection of a continuous or pulsed output for both the LO and ALM Outputs. On = Continuous; Off = Pulsed
- SW2-8** Future Use

### Alarm Jumper Clip Selection

From the factory, ALM is connected to 24 VAC via JW2. By cutting JW2, ALM becomes a dry contact connected to ALG.

### ECM Blower Speeds

The blower speeds can be changed either by using the ECM manual configurations mode method or by using the Aurora AID Tool directly (see Instruction Guide: Aurora Interface and Diagnostics (AID) Tool topic).

### Field Selectable Options via Software

(Selectable via the Aurora AID Tool)

#### ECM Blower Speeds

An ECM blower motor can be driven directly using the onboard PWM output. Four blower speeds are available, based upon the “G”, Y1 (low), Y2 (high), and Aux input signals to the board. The blower speeds can be changed either by the ECM manual configurations mode method (see ECM Configuration Mode topic) or by using the Aurora AID Tool directly. All four blower speeds can be set to the same speed if desired. Aux blower speed will remain at default or current setting and requires the AID Tool for adjustment.

### Safety Features

The following safety features are provided to protect the compressor, heat exchangers, wiring and other components from damage caused by operation outside of design conditions.

**Fuse** – a 3 amp automotive type plug-in fuse provides protection against short circuit or overload conditions.

**Anti-Short Cycle Protection** – 4 minute anti-short cycle protection for the compressor.

**Random Start** – 5 to 80 second random start upon power up.

**Fault Retry** – in the fault condition, the control will stage off the outputs and then “try again” to satisfy the thermostat Y input call. Once the thermostat input calls are satisfied, the control will continue on as if no fault occurred. If 3 consecutive faults occur without satisfying the thermostat Y input call, then the control will go to Lockout mode.

**Lockout** – when locked out, the blower will operate continuously in “G” speed, and PSC blower motor output will remain on. The Alarm output (ALM) and Lockout output (L) will be turned on. The fault type identification display LED1 (Red) shall flash the fault code. To reset lockout conditions with SW2-8 On, thermostat inputs “Y1”, “Y2”, and “W” must be removed for at least 3 seconds. To reset lockout conditions with SW2-8 Off, thermostat inputs “Y1”, “Y2”, “W”, and “DH” must be removed for at least 3 seconds. Lockout may also be reset by turning power off for at least 30 seconds or by enabling the emergency shutdown input for at least 3 seconds.

**Lockout With Emergency Heat** - if the control is locked out in the heating mode, and a Y2 or W input is received, the control will operate in the emergency heat mode while the compressor is locked out. The first emergency heat output will be energized 10 seconds after the W input is received, and the blower will shift to high speed. If the control remains locked out, and the W input is present, additional stage of emergency heat will stage on after 2 minutes. When the W input is removed, all of the emergency heat outputs will turn off, and the ECM blower will shift to “G” speed and PSC blower motor output will remain on.

**High Pressure** – fault is recognized when the Normally Closed High Pressure Switch, P4-9/10 opens, no matter how momentarily. The High Pressure Switch is electrically in series with the Compressor Contactor and serves as a hard-wired limit switch if an overpressure condition should occur.

**Low Pressure** - fault is recognized when the Normally Closed Low Pressure Switch, P4-7/8 is continuously open for 30 seconds. Closure of the LPS any time during the 30 second recognition time restarts the 30 second continuous open requirement. A continuously open LPS shall not be recognized during the 2 minute startup bypass time.

**Loss of Charge** – fault is recognized when the Normally Closed Low Pressure Switch, P4-7/8 is open prior to the compressor starting.

**Condensate Overflow** - fault is recognized when the impedance between this line and 24 VAC common or chassis ground drops below 100K ohms for 30 seconds continuously.

**Freeze Detection (Coax)** - set points shall be either 30°F or 15°F. When the thermistor temperature drops below the selected set point, the control shall begin counting down the 30 seconds delay. If the thermistor value rises above the selected set point, then the count should reset. The resistance value must remain below the selected set point for the entire length of the appropriate delay to be recognized as a fault. This fault will be ignored for the initial 2 minutes of the compressor run time.

**Freeze Detection (Air Coil)** - uses the FP2 input to protect against ice formation on the air coil. The FP2 input will operate exactly like FP1 except that the set point is 30 degrees and is not field adjustable.



## Controls - Aurora Base Control cont.

**Over/Under Voltage Shutdown** - An over/under voltage condition exists when the control voltage is outside the range of 18 VAC to 30 VAC. If the over/under voltage shutdown lasts for 15 minutes, the lockout and alarm relay will be energized. Over/under voltage shutdown is self-resetting in that if the voltage comes back within range of 18 VAC to 30 VAC for at least 0.5 seconds, then normal operation is restored.

### Operation Description

**Power Up** - The unit will not operate until all the inputs and safety controls are checked for normal conditions. The unit has a 5 to 80 second random start delay at power up. Then the compressor has a 4 minute anti-short cycle delay after the random start delay.

Standby In standby mode, Y1, Y2, W, DH, and G are not active. Input O may be active. The blower and compressor will be off.

### Heating Operation

**Heating, 1st Stage (Y1)** - The blower is started on "G" speed immediately and the compressor is energized 10 seconds after the Y1 input is received. The ECM blower motor is switched to low speed 15 seconds after the Y1 input.

**Heating, 2nd Stage (Y1, Y2)** - The compressor will be staged to full capacity 20 seconds after Y2 input is received. The ECM blower will shift to high speed 15 seconds after the Y2 input is received.

**Heating, 3rd Stage (Y1, Y2, W)** - The hot water pump is de-energized and the first stage of electric heat is energized 10 seconds after the W command is received. If the demand continues the second stage of electric heat will be energized after 5 minutes.

**Emergency Heat (W)** - The blower will be started on "G" speed, 10 seconds later the first stage of electric heat will be turned on. 5 seconds after the first stage of electric heat is energized the blower will shift to Aux speed. If the emergency heat demand is not satisfied after 2 minutes the second electric heat stage will be energized.

**Blower (G)** - The blower will start immediately upon receiving a thermostat G command. If there are no other commands from the thermostat the ECM will run on "G" speed until the G command is removed. Regardless of blower input (G) from the thermostat, the blower will remain on for 30 seconds at the end of each heating cycle.

### Cooling Operation

In all cooling operations, the reversing valve directly tracks the O input. Thus, anytime the O input is present, the reversing valve will be energized.

**Cooling, 1st Stage (Y1, O)** - The blower is started on "G" speed immediately and the compressor is energized 10 seconds after the Y1 input is received. The ECM blower motor is switched to low speed 15 seconds after the Y1 input.

**Cooling, 2nd Stage (Y1, Y2, O)** - The compressor will be staged to full capacity 20 seconds after Y2 input is received. The ECM blower will shift to high speed 15 seconds after the Y2 input is received.

**Blower (G)** - The blower will start immediately upon receiving a thermostat G command. If there are no other commands from the thermostat the ECM will run on "G" speed until the G command is removed. Regardless of blower input (G) from the thermostat, the blower will remain on for 30 seconds at the end of each heating, cooling, and emergency heat cycle.

**Dehumidification (Y1, O, DH or Y1, Y2, O, DH)** - When a DH command is received from the thermostat during a compressor call for cooling the ECM blower speed will be reduced by 15% to increase dehumidification.

**Emergency Shutdown** - Four (4) seconds after a valid ES input, P2-7 is present, all control outputs will be turned off and remain off until the emergency shutdown input is no longer present. The first time that the compressor is started after the control exits the emergency shutdown mode, there will be an anti-short cycle delay followed by a random start delay. Input must be tied to common to activate.

**Continuous Blower Operation** - The blower output will be energized any time the control has a G input present, unless the control has an emergency shutdown input present. The blower output will be turned off when G input is removed.

**Load Shed** - The LS input disables all outputs with the exception of the blower output. When the LS input has been cleared, the anti-short cycle timer and random start timer will be initiated. Input must be tied to common to activate.

# Controls - Aurora Base Control cont.

## Aurora 'Base' Control LED Displays

These three LEDs display the status, configuration, and fault codes for the control. These can also be read in plain English via the Aurora AID Tool.

### Status LED (LED3, Green)

| Description of Operation  | Fault LED, Green |
|---------------------------|------------------|
| Normal Mode               | ON               |
| Control is Non-functional | OFF              |
| Test Mode                 | Slow Flash       |
| Lockout Active            | Fast Flash       |
| Dehumidification Mode     | Flash Code 2     |
| (Future Use)              | Flash Code 3     |
| (Future Use)              | Flash Code 4     |
| Load Shed                 | Flash Code 5     |
| ESD                       | Flash Code 6     |
| (Future Use)              | Flash Code 7     |

### Configuration LED (LED2, Yellow)

| Description of Operation   | Configuration LED, Yellow |
|----------------------------|---------------------------|
| No Software Overwritten    | Flashing ECM Setting      |
| DIP Switch was Overwritten | Slow Flash                |
| ECM Configuration Mode     | Fast Flash                |

### Fault LED (LED1, Red)

| Red Fault LED    |                                | LED Flash Code* | Lockout | Reset/Remove |
|------------------|--------------------------------|-----------------|---------|--------------|
| ABC Basic Faults | Normal - No Faults             | OFF             | -       |              |
|                  | Fault - Input                  | 1               | No      | Auto         |
|                  | Fault - High Pressure          | 2               | Yes     | Hard or Soft |
|                  | Fault - Low Pressure           | 3               | Yes     | Hard or Soft |
|                  | Fault - Freeze Detection FP2   | 4               | Yes     | Hard or Soft |
|                  | Fault - Freeze Detection FP1   | 5               | Yes     | Hard or Soft |
|                  | Fault - Condensate Overflow    | 7               | Yes     | Hard or Soft |
|                  | Fault - Over/Under Voltage     | 8               | No      | Auto         |
|                  | Fault - FP1 & FP2 Sensor Error | 11              | Yes     | Hard or Soft |

**NOTE:** All codes >11 use long flash for tens digit and short flash for the ones digit. 20, 30, 40, 50, etc. are skipped.

## Aurora Interface and Diagnostics (AID) Tool

The Aurora Interface and Diagnostics (AID) Tool is a device that is a member of the Aurora network. The AID Tool is used to troubleshoot equipment which uses the Aurora control via Modbus RTU communication. The AID Tool provides diagnostics, fault management, ECM setup, and system configuration capabilities to the Aurora family of controls. An AID Tool is recommended, although not required, for ECM airflow settings. The AID Tool simply plugs into the exterior of the cabinet in the AID Tool port.



## ABC Control Board Layout

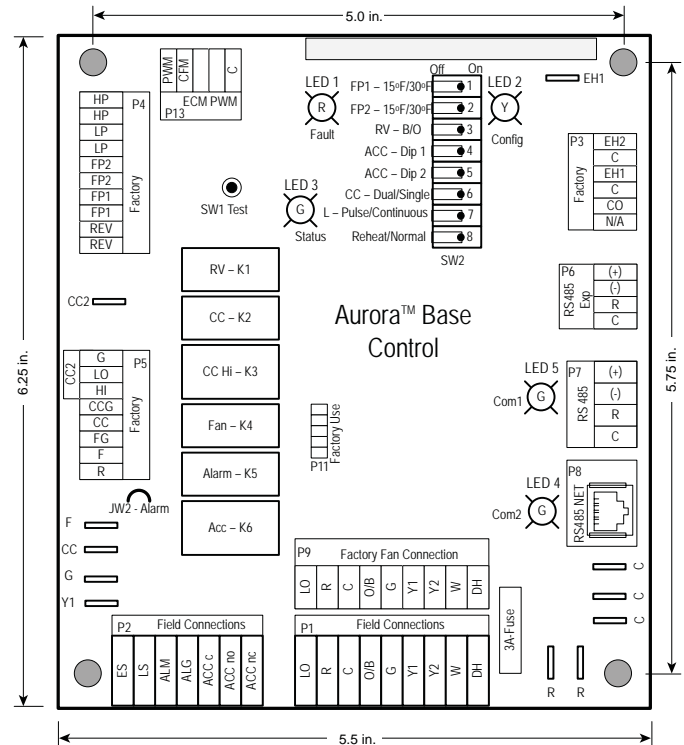

## Controls - FX10 (optional)

### Optional FX10 Microprocessor and BAS Interface

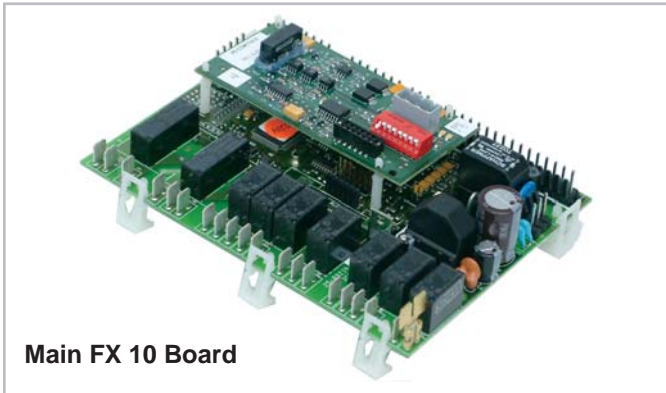

Main FX 10 Board

The FX10 is a microprocessor based control that not only monitors and controls the heat pump but also can communicate any of this information back to the building automation system (BAS). This means that not only does the control monitor the heat pump at the unit you can also monitor and control many the features over the BAS. This clearly puts the FX10 in a class of its own.

The control will enumerate all fault conditions (HP, LP, CO, LOC, and Freeze Detection) over a BAS as well as display them on a medium user interface (MUI). HP, LP, CO and Freeze Detection faults can all be reset over a BAS. A Loss Of Charge fault can not be reset or bypassed until the problem has been corrected. A MUI is invaluable as a service tool for the building service team.

The unit can be commanded to run by a typical heat pump thermostat or run based on heating and cooling set points supplied by a BAS. The control board is wired with quick connect harnesses for easy field change out of a bad control board. All variable speed ECM blower speed settings can be changed over a BAS or with a MUI. The control has an input programmed to enable field installed emergency heat in the event that the compressor is locked out. This input can also be commanded on from a BAS as needed. An alarm history can be viewed through the MUI and will be held in memory until the unit is power cycled. Relative humidity can be read by a 0-5VDC humidity sensor that is displayed over the network. If you are using a variable speed ECM blower motor the control can enable dehumidification mode based on a set point in the control. The dehumidification set point itself can also be changed over a BAS or with a MUI. Dehumidification mode can also be enabled by the BAS. Because the FX10 is not factory configured to read CO<sup>2</sup> levels, contact the factory for application assistance.

The FX10 control has unused analog and digital inputs for field installed items such as air temperature, water temperature, CO<sup>2</sup> or current status switches. The control has unused binary and PWM outputs that can be commanded over the BAS for field use.

An optional Medium User Interface (MUI) for control setup and advanced diagnostics is available with some mounting kits, MUIK3 - Panel mount version and the MUIK4-Wall mount version.

### Zone Sensors

There are two options for zone sensors that can be used with the FX10 control. Both sensors use a Johnson controls A99 positive temperature coefficient type sensor. The TAXXJ02 has a set point adjustment now which will give the end user a +/- 5°F adjustment from the set point as well as a push button that can be used for temporary occupancy. The control leaves the factory set to operate with a TAXXJ02 sensor, the TAXXA04 sensor through a building automation system, or with a user interface.

### Standard Features

- Anti Short Cycle
- High Pressure Protection
- Low Pressure Protection
- Freeze Detection
- Loss Of Charge Detection
- Random Start
- Display for diagnostics
- Reset Lockout at disconnect or through BAS
- 2 Accessory outputs
- Optional BAS add-on controls

### DDC Operation and Connection

Other optional network protocol boards that can be added to the FX10 are:

- Johnson Control N2
- LonWorks
- BACnet
  - MS/TP @ 19,200 Baud rate
  - Limit devices to 30 on a single trunk line

### Control and Safety Feature Details Emergency Shutdown

The emergency shutdown mode can be activated by a command from a facility management system or a closed contact on BI-2. The default state for the emergency shutdown data point is off. When the emergency shutdown mode is activated, all outputs will be turned off immediately and will remain off until the emergency shutdown mode is de-activated. The first time the compressor starts after the emergency shutdown mode has been de-activated, there will be a random start delay present.

## Controls - FX10 (optional) cont.

### Lockout Mode

Lockout mode can be activated by any of the following fault signals: refrigerant system high pressure, refrigerant system low pressure, freeze detection, and condensate overflow. When any valid fault signal remains continuously active for the length of its recognition delay, the controller will go into fault retry mode, which will turn off the compressor. After the Compressor short cycle delay, the compressor will attempt to operate once again. If three consecutive faults occur in 60 minutes during a single heating or cooling demand, the unit will go into lockout mode, turning off the compressor, enabling the alarm output, and setting the blower back to low speed operation until the controller is reset. If the control faults due to the low pressure input (BI-3) being open during the pre-compressor startup check, the control will go into lockout mode immediately, disabling the compressor from starting and enabling the alarm output (BO-6). The lockout condition can be reset by powering down the controller, by a command from the BAS, or by the holding the ESC and Return keys on the MUI for 5 seconds.



### Freeze Detection (AI-5)

The freeze detection sensor will monitor the liquid refrigerant temperature entering the water coil in the heating mode. If the temperature drops below the freeze detection trip point for the recognition delay period, the condition will be recognized as a fault. The freeze detection trip point will be factory set for 30°F (-1°C) and will be field selectable for 15°F (-9°C) by removing a jumper wire on BI-5. The freeze detection fault condition will be bypassed 2 minutes at normal compressor startup, to allow the refrigeration circuit to stabilize. If the freeze detection sensor becomes unreliable at any time compressor operation will immediately be suspended until the problem is corrected. This should be displayed as an alarm on the BAS and the MUI. This alarm will be reported as a "Water Low Temp Limit" fault.

### High Pressure (BI-11)

The high-pressure switch shall be a normally closed (NC) switch that monitors the systems refrigerant pressure. If the input senses the high-pressure switch is open it must disable the compressor output immediately and count the fault. The compressor minimum on time does not apply if the high-pressure switch opens. The compressor will not restart until the compressor short cycle time delay has been satisfied.

### Low Pressure (BI-3)

The low-pressure switch shall be a normally closed (NC) switch that monitors the systems refrigerant pressure. The input shall be checked 15 seconds before compressor start up to be sure the pressure switch is closed and then ignored for the first 2 minutes after the compressor output (BO-2) is enabled. If the switch is open continuously for (30) seconds during compressor operation the compressor output (BO-2) will be disabled. The compressor will not restart until the compressor short cycle time delay has been satisfied.

### Condensate Overflow

The condensate overflow sensing circuit will monitor the condensate level as a resistance input to AI-3. If the condensate water level rises resulting in the input resistance rising above the set point for the recognition delay period, the condition will be recognized as a fault. The condensate will be subjected to a (30) second lockout delay which requires that the fault be sensed for a continuous (30) seconds before suspending unit operation.

### Alarm Output (BO-6)

The alarm output will be enabled when the control is in the lockout mode and will be disabled when the lockout is reset.

### Test Mode

Raising the zone temperature input (AI-1) reading to 180–220°F or by holding the ESC and down arrow keys on the MUI for 5 seconds will put the control into test mode. In test mode the random start delay and the compressor fixed on delay time will both be shortened to 5 seconds and the reversing valve will be allowed to cycle with out shutting down the compressor. If an MUI is connected to the control LED 8 will flash and the words "Test Mode Enabled" will be shown on the LCD display when the control is in test mode. Test mode will be disabled after a power cycle, 30 minute timeout, or by holding the ESC and Up arrow keys on the MUI.

## Sequence of Operation

### Power Fail Restart

When the controller is first powered up, the outputs will be disabled for a random start delay. The delay is provided to prevent simultaneous starting of multiple heat pumps. Once the timer expires, the controller will operate normally.

### Random Start Delay

This delay will be used after every power failure, as well as the first time the compressor is started after the control exits the unoccupied mode or the emergency shutdown mode. The delay should not be less than 1 second and not longer than 120 seconds. If the control is in test mode the random start delay will be shortened to 5 seconds.

## Controls - FX10 (optional) cont.

### Compressor Fixed On Delay Time

The Compressor Fixed On Delay Time will ensure that the compressor output (BO2) is not enabled for 90 seconds after the control receives a call to start the compressor. This delay is adjustable from 30 – 300 seconds over a BAS or a MUI. If the control is in test mode the Compressor Fixed On Delay Timer will be shortened to 5 seconds.

### Compressor Minimum On Delay

The compressor minimum on delay will ensure that the compressor output is enabled for a minimum of two (2) minute each time the compressor output is enabled. This will apply in every instance except in the event the high pressure switch is tripped or emergency shutdown then the compressor output will be disable immediately.

### Compressor Short Cycle Delay Time

The compressor short cycle time delay will ensure that the compressor output will not be enabled for a minimum of five (5) minutes after it is disabled. This allows for the system refrigerant pressures to equalize after the compressor is disabled.

## Heating Cycle

On a call for heating, the blower enable output and accessory output 2 will turn on immediately after the random start delay timer has been satisfied. If the compressor short cycle time delay has been satisfied, the compressor will turn on after the blower enable and accessory output 2 are on and the fixed compressor start delay timers have been satisfied. **NOTE:** Auxiliary heat output can be controlled over the BAS.

#### Set Point Control Mode

In set point control mode the reversing valve output will be disabled. As the temperature drops below the heating set point and begins to operate in the heating proportional band, the compressor (low capacity for two-stage compressors) output (BO-2) will be enabled. For units with two-stage compressors, a PI loop in the programming of the control will determine when the full capacity compressor output (BO-4) is to be enabled. The compressor must be operating in low capacity for a minimum of 30 seconds before the full capacity compressor output can be enabled. During low capacity compressor operation the variable speed ECM blower will operate in medium speed and will operate in high speed when the compressor is operating at full capacity.

#### Thermostat Control Mode

In thermostat mode the compressor will be cycled based on Y1 and Y2 calls from a room thermostat. When the control receives a Y1 command (BI-7) from the thermostat the low capacity compressor output (BO2) will be enabled and the variable speed ECM blower will operate in medium speed. When the control receives a Y2 command (BI-8) from the

thermostat the variable speed ECM blower will operate in high speed. During the heating cycle the reversing valve will be commanded into the off position.

## Cooling Cycle

On a call for cooling, the blower enable output and accessory output 2 will turn on immediately after the random start delay timer has been satisfied. If the compressor short cycle time delay has been satisfied, the compressor will turn on after the blower enable and accessory output 2 are on and the fixed compressor start delay timers have been satisfied.

#### Set Point Control Mode

In set point control mode the reversing valve output will be enabled. As the temperature rises above the cooling set point and begins to operate in the cooling proportional band, the low capacity compressor output (BO-2) will be enabled. A PI loop in the programming of the control will determine when the full capacity compressor output (BO-4) is to be enabled. The compressor must be operating in low capacity for a minimum of 30 seconds before the full capacity compressor output can be enabled. During low capacity compressor operation the variable speed ECM blower will operate in medium speed and will operate in high speed when the compressor is operating at full capacity.

#### Thermostat Control Mode

In thermostat mode the compressor will be cycled based on Y1 and Y2 calls from a room thermostat. When the control receives a Y1 command (BI-7) from the thermostat the low capacity compressor output (BO2) will be enabled and the variable speed ECM blower will operate in medium speed. When the control receives a Y2 command (BI-8) from the thermostat the full capacity compressor output will be enabled and the variable speed ECM blower will operate in high speed. During the cooling cycle the reversing valve will be commanded into the "ON" position.

## Variable Speed ECM Blower Operation

Blower speeds will be selected through the user interface or the facility management system. There will be a total of 12 speeds selectable with only three being selected at any one time. The lowest numbered speed selection set to ON will select the low-speed blower setting, the middle selection set to ON will select the medium-speed blower setting and the highest selection set to ON will select the high-speed blower setting. If all selections are set to OFF

## Controls - FX10 (optional) cont.

the software shall select speed setting 10 for low-speed, 11 for medium-speed, and will select speed setting 12 for high speed. If only one selection is set to ON, that selection will set the low-speed blower setting, the medium-speed setting will be 11, and the high-speed setting will be speed 12. The maximum low-speed setting will be speed 10 and the minimum high-speed setting will be speed 3. In addition there is a low limit setting in the software to prevent the variable speed ECM blower speed from being set below acceptable limits for each unit size.

### Emergency Heat/Network Enabled Output (BO-5)

This output is set from the factory to enable/disable emergency heat. If a problem occurs with the unit resulting in the compressor being locked out in heating mode, the control will automatically enable this output to turn on field installed electric heat. This output is interlocked with the blower proving input BI-6 (Blower proving sensors must be field supplied and installed). BI-6 must be connected to PB2 position 3 (see unit schematic) in the field if no blower proving sensor is desired. There is a configurable parameter available through a BAS network that must be enabled if this output is to be commanded over the BAS network. **NOTE:** For auto switch over, BO-5 must be set to "Emergency" using the MUI.

### MUI Alarm History Reporting

If a fault occurs the fault will be recorded in history for display on the medium user interface in the History Menu. Each fault type will be displayed in the history menu with a number between 0 and 3.

A reading of 3+ will mean that fault has occurred more than three times in the past. The history menu can be cleared with a power cycle only. Alarm date and time are not included in the history.

## Inputs and Outputs Configuration

### Field Selectable Options

#### Freeze Detection Set Point (BI-5)

The freeze detection set point input allows you to adjust the freeze detection set point (AI-5). When the jumper is installed on BI-5 (Wire #24) the freeze detection set point is factory set for 30°F (-1°C). When the jumper on BI-5 (Wire #24) is removed the freeze detection set point will be 15°F (-9°C).

#### Accessory Outputs (BO-7 and BO-8)

Accessory Output 1 will be energized 90 seconds prior to the compressor output being energized. Accessory Output 2 will be energized with the blower output (BO-1). When the corresponding compressor output is turned off the accessory output will be deactivated immediately. These outputs are selectable for normally open or normally closed operation through the MUI or through the BAS.

## FX10 User Interface (MUI) Physical Layout

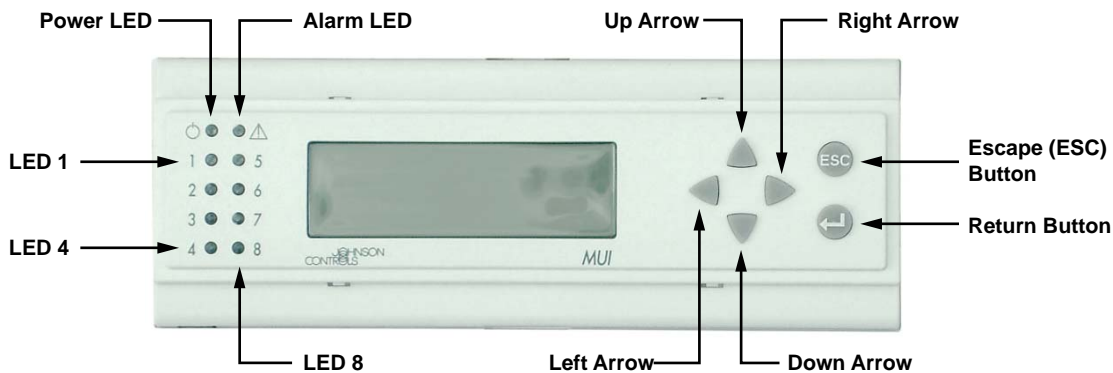

**Alarm LED** - Indicates a **Lock-Out** or a bad **Freeze Sensor**

**Power LED** - Shows FX processor is operational

**LED 1** - Flashing shows **Compressor 1** running

**LED 2** - Flashing shows **Full Capacity Compressor** running

**LED 3** - On shows **Fan** running

**LED 4** - On shows **Reversing Valve** in cool

**LED 8** - Flashing shows unit in **'Test' Mode**

## Controls - FX10 (optional) cont.

### MUI Menu Navigation for Single Compressor - Arbor Base Series Water-to-Air

Welcome

Info   Status   Temps   Outputs   Settings   Maint   Alarms   Alm-History

**Info**

|              |
|--------------|
| Water Source |
| Heat Pump    |
| PROFXENV-XX  |
| ___          |

**Status**

|              |           |
|--------------|-----------|
| Run Mode     | Auto      |
| Eff Occup'y  | Occ       |
| Y1 Input     | OFF       |
| Y2 Input     | OFF       |
| G Input      | OFF       |
| O Input      | Heat/Cool |
| Occ Input    | Occ       |
| Temp Occ Inp | OFF       |
| Condensate   | NML       |
| Emg Input    | Run       |
| Lo Press     | ON        |
| Hi Press     | ON        |
| Rndm Tmr     | 0         |
| BI-4 Input   | OFF       |

**Temps**

|               |          |
|---------------|----------|
| Zone Temp     | 77.2 °F  |
| Dis Air Temp  | 51.0 °F  |
| Eff Clg Setpt | 70.0°F   |
| Eff Htg Setpt | 66.0°F   |
| Water Coil    | 77.8°F   |
| Low WC Limit  | 30.0°F   |
| Humidity      | 56.7 %RH |
| WarmCool Al   | 14.6     |
| WarmCoolAdj   | 0.2      |

**Outputs**

|               |      |
|---------------|------|
| nvoFanStatus  | ON   |
| CmpCmd Status | OFF  |
| Cmp Capacity  | OFF  |
| Rev Valve     | Heat |
| X1 Output     | OFF  |
| X2 Output     | OFF  |
| PWMOut        | 98%  |
| BO5           | OFF  |
| BO9           | OFF  |
| AO2 Output    | 0%   |

**Settings**

|                 |         |
|-----------------|---------|
| Unit of Measure | F       |
| Occ Clg Setpt   | 73.9 °F |
| Occ Htg Setpt   | 69.9 °F |
| Unocc Clg       | 84.0 °F |
| Unocc Htg       | 60.0 °F |
| DeHumSetpt      | 0%      |
| SensorSelect    | TAXXJ02 |

**Maintenance**

|               |                 |
|---------------|-----------------|
| MinClgSetpt   | 60.0 °F         |
| MaxHtgSetpt   | 89.9 °F         |
| W Coil LoLim1 | 30.0 °F         |
| W Coil LoLim2 | 15.0 °F         |
| TmpOccTime    | 120 min         |
| Rev Vlv       | Default Heating |
| BO5 Mode      | Network         |
| CompStrtDly   | 90 sec          |
| SpaceT Offset | -1 °F           |
| DehumEnaDis   | Dis             |
| Acc1 Action   | On Comp         |
| Acc2 Action   | On Fan          |

Press right arrow key  
one time from  
Maintenance Menu

**ECM**

|      |     |
|------|-----|
| SW1  | OFF |
| SW2  | OFF |
| SW3  | ON  |
| SW4  | OFF |
| SW5  | OFF |
| SW6  | OFF |
| SW7  | ON  |
| SW8  | OFF |
| SW9  | OFF |
| SW10 | ON  |
| SW11 | OFF |
| SW12 | OFF |

No more than three  
speeds should be "ON"  
at one time

**Alarms**

|                 |
|-----------------|
| ALARM SUMMARY   |
| ^/High Pressure |

**Alm-History**

| Alarm        | #Events |
|--------------|---------|
| Condensate   | 0       |
| Hi Pressure  | 0       |
| Low Pressure | 0       |
| Low Temp     | 0       |
| Bad Sensor   | 0       |

**NOTE:** This FX10 application implements an **alarm history** which is reset only by cycling power . This history shows on the Alm-History page. Any alarm showing 4+ events has occurred more than 4 times.

**Alarm lock-outs** are reset by cycling power, by pressing the "ESC" and Return  keys simultaneously for a minimum of 15 seconds, or by commanding the nviAlarmReset over the BAS network.

**Test mode** is enabled by holding the 'Esc' and Down Arrow simultaneously for a minimum of 15 seconds and releasing. Test mode times out after 30 minutes, and may also be ended by pressing 'ESC' and Up Arrow simultaneously and releasing. Test Mode bypasses the On Delay (90 sec) and Random Start timers for quicker troubleshooting. It also allows cycling the reversing valve without compressor shutdown.

## Unit Startup

---

### Before Powering Unit, Check The Following:

**NOTE:** Remove and discard the compressor shipping bolts. The bolts can then be discarded.

- High voltage is correct and matches nameplate.
- Fuses, breakers and wire size correct.
- Low voltage wiring complete.
- Piping completed and water system cleaned and flushed.
- Air is purged from closed loop system.
- Isolation valves are open, water control valves or loop pumps wired.
- Condensate line open and correctly pitched.
- Transformer switched to 208V if applicable.
- Dip switches are set correctly.
- Blower rotates freely – foam shipping support has been removed.
- Blower speed correct.
- Air filter/cleaner is clean and in position.
- Service/access panels are in place.
- Return air temperature is between 50-80°F heating and 60-95°F cooling.
- Check air coil cleanliness to insure optimum performance. Clean as needed according to maintenance guidelines. To obtain maximum performance the air coil should be cleaned before startup. A 10-percent solution of dishwasher detergent and water is recommended for both sides of coil, a thorough water rinse should follow.

### Startup Steps

**NOTE:** Complete the Equipment Start-Up/Commissioning Check Sheet during this procedure. Refer to thermostat operating instructions and complete the startup procedure.

1. Initiate a control signal to energize the blower motor. Check blower operation.
2. Initiate a control signal to place the unit in the cooling mode. Cooling setpoint must be set below room temperature.
3. Cooling will energize after a time delay. Check for correct rotation of scroll compressors in 3 phase applications. Incorrect rotation will cause low refrigerant pressures and possibly unusual noise. Switch any two power leads at the compressor or contactor to reverse rotation.
4. Be sure that the compressor and water control valve or loop pump(s) are activated.
5. Verify that the water flow rate is correct by measuring the pressure drop through the heat exchanger using the P/T plugs and comparing to the pressure drop table.
6. Check the temperature of both the supply and discharge water (Refer to Operating Parameters tables).
7. Check for an air temperature drop of 15°F to 25°F across the air coil, depending on the blower speed and entering water temperature.
8. Decrease the cooling set point several degrees and verify high-speed blower operation (variable speed ECM only).
9. Adjust the cooling setpoint above the room temperature and verify that the compressor and water valve or loop pumps deactivate.
10. Initiate a control signal to place the unit in the heating mode. Heating set point must be set above room temperature.
11. Heating will energize after a time delay.
12. Check the temperature of both the supply and discharge water (Refer to Unit Operating Parameters tables).
13. Check for an air temperature rise of 20°F to 35°F across the air coil, depending on the blower speed and entering water temperature.
14. If auxiliary electric heaters are installed, increase the heating setpoint until the electric heat banks are sequenced on. All stages of the auxiliary heater should be sequenced on when the thermostat is in the Emergency Heat mode. Check amperage of each element.
15. Adjust the heating setpoint below room temperature and verify that the compressor and water valve or loop pumps deactivate.
16. During all testing, check for excessive vibration, noise or water leaks. Correct or repair as required.
17. Set system to desired normal operating mode and set temperature to maintain desired comfort level.
18. Instruct the owner/operator in the proper operation of the thermostat and system maintenance.

**NOTE:** Be certain to fill out and forward all warranty registration papers.



## Operating Parameters

| Entering Water Temp °F | Water Flow GPM/ton | Cooling               |                         |           |            |                    |                     |
|------------------------|--------------------|-----------------------|-------------------------|-----------|------------|--------------------|---------------------|
|                        |                    | Suction Pressure psig | Discharge Pressure psig | Superheat | Subcooling | Water Temp Rise °F | Air Temp Drop °F DB |
| 30                     | 1.5                | 100-115               | 170-190                 | 17 - 26   | 10 - 14    | 18 - 22            | 18 - 22             |
|                        | 3.0                | 95-110                | 150-170                 | 20 - 29   | 7 - 11     | 8 - 10             | 18 - 22             |
| 50                     | 1.5                | 133 - 148             | 205 - 225               | 17 - 26   | 10 - 14    | 18 - 22            | 18 - 22             |
|                        | 3.0                | 129 - 144             | 185 - 205               | 20 - 29   | 7 - 11     | 8 - 10             | 18 - 22             |
| 70                     | 1.5                | 139 - 154             | 280 - 300               | 8 - 11    | 8-12       | 18 - 22            | 18 - 22             |
|                        | 3.0                | 137 - 152             | 250 - 270               | 9 - 12    | 7 - 11     | 8 - 10             | 18 - 22             |
| 90                     | 1.5                | 143 - 158             | 360 - 380               | 8 - 11    | 9 - 13     | 18 - 22            | 16 - 20             |
|                        | 3.0                | 141 - 156             | 330 - 350               | 9 - 12    | 8 - 12     | 8 - 10             | 16 - 20             |
| 110                    | 2.3                | 143 - 158             | 360 - 380               | 8 - 11    | 9 - 13     | 18 - 22            | 16 - 20             |
|                        | 3.0                | 141 - 156             | 440-460                 | 9 - 12    | 8 - 12     | 8 - 10             | 16 - 20             |

| Entering Water Temp °F | Water Flow GPM/ton | Heating               |                         |           |            |                    |                     |
|------------------------|--------------------|-----------------------|-------------------------|-----------|------------|--------------------|---------------------|
|                        |                    | Suction Pressure psig | Discharge Pressure psig | Superheat | Subcooling | Water Temp Drop °F | Air Temp Rise °F DB |
| 30                     | 1.5                | 73 - 79               | 279 - 304               | 7 - 13    | 2 - 6      | 7 -10              | 18 - 24             |
|                        | 3.0                | 79 - 85               | 285 - 310               | 8 - 14    | 2 - 6      | 3 - 6              | 20 - 26             |
| 50                     | 1.5                | 103 - 109             | 308 - 333               | 8 - 12    | 4 - 8      | 8 - 11             | 20 - 26             |
|                        | 3.0                | 110 - 116             | 315 - 340               | 9 - 13    | 4 - 8      | 4 - 7              | 22 - 28             |
| 70                     | 1.5                | 140 - 146             | 330 - 365               | 10 - 14   | 7 - 11     | 11 - 14            | 26 - 32             |
|                        | 3.0                | 146 - 153             | 340 - 375               | 10 - 14   | 7 - 11     | 7 - 10             | 28 - 34             |
| 90                     | 1.5                | 170-177               | 425-460                 | 14-18     | 12-16      | 8-11               | 42-50               |
|                        | 3.0                | 174-181               | 435-470                 | 14-18     | 12-16      | 8-11               | 42-50               |
| 110                    | 2.3                |                       |                         |           |            |                    |                     |
|                        | 3.0                |                       |                         |           |            |                    |                     |

NOTES: Cooling performance based on entering air temperatures of 80°F DB, 67°F WB.  
 Heating performance based on entering air temperature of 70°F DB.

5/1/11

## Operating Limits

| Operating Limits         | Cooling   |         | Heating |      |
|--------------------------|-----------|---------|---------|------|
|                          | (°F)      | (°C)    | (°F)    | (°C) |
| <b>Air Limits</b>        |           |         |         |      |
| Min. Ambient Air         | 45        | 7.2     | 45      | 7.2  |
| Rated Ambient Air        | 80        | 26.7    | 70      | 21.1 |
| Max. Ambient Air         | 100       | 37.8    | 85      | 29.4 |
| Min. Entering Air        | 50        | 10.0    | 40      | 4.4  |
| Rated Entering Air db/wb | 80.6/66.2 | 27/19   | 68      | 20.0 |
| Max. Entering Air db/wb  | 110/83    | 43/28.3 | 80      | 26.7 |
| <b>Water Limits</b>      |           |         |         |      |
| Min. Entering Water      | 30        | -1.1    | 20      | -6.7 |
| Normal Entering Water    | 50-110    | 10-43.3 | 30-70   | -1.1 |
| Max. Entering Water      | 120       | 48.9    | 90      | 32.2 |

**NOTE:** Minimum/maximum limits are only for start-up conditions, and are meant for bringing the space up to occupancy temperature. Units are not designed to operate at the minimum/maximum conditions on a regular basis. The operating limits are dependent upon three primary factors: 1) water temperature, 2) return air temperature, and 3) ambient temperature. When any of the factors are at the minimum or maximum levels, the other two factors must be at the normal level for proper and reliable unit operation.

## Pressure Drop

| Model | GPM  | Pressure Drop (psi) |      |      |      |       |
|-------|------|---------------------|------|------|------|-------|
|       |      | 30°F                | 50°F | 70°F | 90°F | 110°F |
| 006   | 1.0  | 1.2                 | 1.2  | 1.1  | 1.0  | 1.0   |
|       | 1.5  | 2.2                 | 2.0  | 1.9  | 1.8  | 1.7   |
|       | 2.0  | 3.3                 | 3.1  | 2.9  | 2.7  | 2.5   |
|       | 2.5  | 4.1                 | 3.8  | 3.4  | 3.1  | 2.9   |
| 009   | 1.5  | 1.9                 | 1.7  | 1.5  | 1.3  | 1.1   |
|       | 2.0  | 3.0                 | 2.8  | 2.6  | 2.4  | 2.2   |
|       | 3.0  | 6.3                 | 6.3  | 6.1  | 5.9  | 5.7   |
|       | 4.0  | 8.1                 | 7.9  | 7.4  | 6.8  | 6.1   |
| 012   | 1.5  | 1.1                 | 1.1  | 1.0  | 0.9  | 0.9   |
|       | 2.5  | 2.4                 | 2.3  | 2.2  | 2.0  | 1.9   |
|       | 3.5  | 4.2                 | 4.0  | 3.7  | 3.4  | 3.2   |
|       | 4.5  | 6.1                 | 5.9  | 5.2  | 4.7  | 4.1   |
| 015   | 2.0  | 1.8                 | 1.7  | 1.6  | 1.4  | 1.2   |
|       | 3.0  | 3.3                 | 3.1  | 2.9  | 2.6  | 2.3   |
|       | 4.0  | 5.0                 | 4.9  | 4.8  | 4.7  | 4.6   |
|       | 5.0  | 7.1                 | 6.7  | 5.9  | 5.4  | 5.1   |
| 018   | 3.0  | 3.3                 | 3.2  | 3.0  | 2.8  | 2.6   |
|       | 4.0  | 4.7                 | 4.2  | 3.9  | 3.6  | 3.1   |
|       | 5.0  | 6.2                 | 5.2  | 4.7  | 4.1  | 3.5   |
|       | 6.0  | 7.7                 | 6.2  | 5.4  | 4.6  | 3.8   |
| 024   | 3.0  | 3.2                 | 3.1  | 2.9  | 2.7  | 2.5   |
|       | 4.5  | 6.1                 | 5.5  | 4.9  | 4.5  | 4.2   |
|       | 6.0  | 9.0                 | 7.9  | 6.9  | 6.3  | 5.8   |
|       | 8.0  | 12.9                | 10.9 | 9.5  | 8.8  | 7.9   |
| 030   | 4.0  | 2.4                 | 2.3  | 2.2  | 2.0  | 1.8   |
|       | 6.0  | 5.1                 | 4.9  | 4.7  | 4.5  | 4.3   |
|       | 8.0  | 7.8                 | 7.5  | 7.1  | 6.9  | 6.7   |
|       | 10.0 | 10.5                | 10.1 | 9.6  | 9.3  | 8.9   |
| 036   | 5.0  | 2.0                 | 1.9  | 1.7  | 1.5  | 1.4   |
|       | 7.0  | 3.6                 | 3.5  | 3.3  | 3.1  | 2.9   |
|       | 9.0  | 5.2                 | 5.1  | 4.8  | 4.6  | 4.4   |
|       | 12.0 | 7.5                 | 7.4  | 7.1  | 6.9  | 6.7   |
| 042   | 5.0  | 2.1                 | 2.0  | 1.8  | 1.6  | 1.4   |
|       | 8.0  | 4.8                 | 4.7  | 4.5  | 4.4  | 4.2   |
|       | 11.0 | 7.5                 | 7.4  | 7.0  | 6.6  | 6.1   |
|       | 14.0 | 10.1                | 9.9  | 9.6  | 8.8  | 8.1   |
| 048   | 6.0  | 2.7                 | 2.6  | 2.4  | 2.2  | 2.0   |
|       | 9.0  | 6.0                 | 5.9  | 5.4  | 5.2  | 5.1   |
|       | 12.0 | 9.5                 | 9.3  | 8.5  | 8.3  | 8.1   |
|       | 16.0 | 14.2                | 13.9 | 12.7 | 12.3 | 12.1  |
| 060   | 9.0  | 4.5                 | 4.4  | 4.2  | 4.0  | 3.8   |
|       | 12.0 | 6.5                 | 6.3  | 6.1  | 5.9  | 5.7   |
|       | 15.0 | 8.6                 | 8.1  | 7.9  | 7.7  | 7.5   |
|       | 20.0 | 12.1                | 11.2 | 10.8 | 10.6 | 10.4  |
| 070   | 12.0 | 5.7                 | 5.6  | 5.4  | 5.2  | 5.0   |
|       | 15.0 | 8.9                 | 8.6  | 8.2  | 7.7  | 6.7   |
|       | 18.0 | 12.0                | 11.5 | 11.0 | 10.1 | 8.4   |
|       | 24.0 | 17.4                | 16.9 | 16.5 | 15.1 | 11.8  |

9/5/12

| Valve   | GPM  | Cv   | Pressure Drop (psi) |
|---|------|------|---------------------|
| Internally mounted 2-position solenoid water valves are not available on models 006-012 |      |      |                     |
| 1/2"  | 3.0  | 9.9  | 0.09                |
|   | 4.0  | 10.1 | 0.16                |
|   | 5.0  | 10.4 | 0.23                |
|   | 6.0  | 10.6 | 0.32                |
| 1/2"  | 3.0  | 9.9  | 0.09                |
|   | 4.0  | 10.1 | 0.16                |
|   | 5.0  | 10.4 | 0.23                |
|   | 6.0  | 10.6 | 0.32                |
| 3/4"  | 3.0  | 9.9  | 0.09                |
|   | 4.5  | 10.2 | 0.19                |
|   | 6.0  | 10.6 | 0.32                |
|   | 8.0  | 11.0 | 0.53                |
| 3/4"  | 4.0  | 10.1 | 0.16                |
|   | 6.0  | 10.6 | 0.32                |
|   | 8.0  | 11.0 | 0.53                |
|   | 10.0 | 11.5 | 0.76                |
| 3/4"  | 5.0  | 10.4 | 0.23                |
|   | 7.0  | 10.8 | 0.42                |
|   | 9.0  | 11.2 | 0.64                |
|   | 12.0 | 11.9 | 1.02                |
| 3/4"  | 5.0  | 10.4 | 0.23                |
|   | 8.0  | 11.0 | 0.53                |
|   | 11.0 | 11.7 | 0.89                |
|   | 14.0 | 12.3 | 1.29                |
| 3/4"  | 6.0  | 10.6 | 0.32                |
|   | 9.0  | 11.2 | 0.64                |
|   | 12.0 | 11.9 | 1.02                |
|   | 16.0 | 12.8 | 1.57                |
| 1"  | 9.0  | 16.8 | 0.29                |
|   | 12.0 | 17.4 | 0.47                |
|   | 15.0 | 18.1 | 0.69                |
|   | 20.0 | 19.2 | 1.09                |
| 1"  | 12.0 | 17.4 | 0.47                |
|   | 15.0 | 18.1 | 0.69                |
|   | 18.0 | 18.7 | 0.92                |
|   | 24.0 | 20.1 | 1.43                |

9/5/12

# Compressor and Thermistor Resistance

## Compressor Resistance

| Model | 115/60/1                             |           | 208-230/60/1 |           | 265/60/1  |           | 208-230/60/3 | 460/60/3  | 575/60/4  |
|-------|--------------------------------------|-----------|--------------|-----------|-----------|-----------|--------------|-----------|-----------|
|       | Run                                  | Start     | Run          | Start     | Run       | Start     |              |           |           |
| 006   | 1.25-1.43                            | 2.70-3.10 | 5.30-6.09    | 5.12-5.89 | 8.33-9.59 | 4.25-4.89 |              |           |           |
| 009   | 0.77-0.89                            | 1.79-2.05 | 3.65-4.19    | 3.75-4.31 | 3.73-4.27 | 4.45-5.13 |              |           |           |
| 012   | Not Available at Time of Publication |           | 3.35-3.85    | 2.80-3.22 | 3.73-4.27 | 4.45-5.13 |              |           |           |
| 015   |                                      |           | 2.74-3.16    | 2.60-3.00 | 3.03-3.49 | 2.39-2.75 |              |           |           |
| 018   |                                      |           | 2.24-2.58    | 2.84-3.26 | 3.03-3.49 | 2.39-2.75 |              |           |           |
| 024   |                                      |           | 1.36-1.50    | 2.26-2.50 | 1.33-1.47 | 2.34-2.58 | 1.29-1.43    | 5.06-5.6  |           |
| 030   |                                      |           | 0.93-1.03    | 1.64-1.82 | 1.33-1.47 | 2.34-2.58 | 1.29-1.43    | 5.06-5.6  |           |
| 036   |                                      |           | 0.60-0.66    | 1.20-1.32 | 0.76-0.84 | 1.67-1.85 | 1.09-1.21    | 4.38-4.84 |           |
| 042   |                                      |           | 0.49-0.55    | 1.56-1.73 |           |           | 1.09-1.21    | 4.38-4.84 | 6.88-7.60 |
| 048   |                                      |           | 0.51-0.57    | 1.58-1.74 |           |           | 0.88-0.97    | 3.41-3.77 | 5.39-5.96 |
| 060   |                                      |           | 0.43-0.48    | 1.33-1.47 |           |           | 0.88-0.97    | 2.78-3.07 | 5.39-5.96 |
| 070   |                                      |           | 0.35-0.40    | 1.34-1.54 |           |           | 0.71-0.81    | 2.72-3.13 | 4.27-4.92 |

09/26/12

## Thermistor Resistance

| Thermistor Temperature (°F) | Microprocessor Resistance (Ohms) | FX10 Resistance (Ohms) |
|-----------------------------|----------------------------------|------------------------|
| 5                           | 72,950                           | 746-770                |
| 14                          | 55,330                           | 775-803                |
| 23                          | 42,330                           | 808-836                |
| 32                          | 32,650                           | 841-869                |
| 41                          | 25,390                           | 875-903                |
| 50                          | 19,900                           | 910-938                |
| 59                          | 15,710                           | 946-974                |
| 68                          | 12,490                           | 981-1013               |
| 77                          | 10,000                           | 1019-1051              |
| 86                          | 8,057                            | 1058-1090              |
| 95                          | 6,530                            | 1097-1129              |
| 104                         | 5,327                            | 1137-1169              |
| 113                         | 4,370                            | 1179-1211              |
| 122                         | 3,603                            | 1221-1253              |
| 131                         | 2,986                            | 1261-1297              |
| 140                         | 2,488                            | 1305-1341              |
| 149                         | 2,083                            | 1350-1386              |

5/1/11

## Refrigerant Circuit Guideline

| Symptom                                       | Head Pressure | Suction Pressure | Compressor Amp Draw | Superheat   | Subcooling  | Air Temp. Differential                                      | Water Temp. Differential |
|---|---------------|------------------|---------------------|-------------|-------------|---|--------------------------|
| Under Charged System (Possible Leak)          | Low           | Low              | Low                 | High        | Low         | Low   | Low                      |
| Over Charged System                           | High          | High             | High                | Normal      | High        | Normal/Low  | Normal                   |
| Low Air Flow Heating                          | High          | High             | High                | High/Normal | Low         | High  | Low                      |
| Low Air Flow Cooling                          | Low           | Low              | Low                 | Low/Normal  | High        | High  | Low                      |
| Low Water Flow Heating                        | Low/Normal    | Low/Normal       | Low                 | Low         | High        | Low   | High                     |
| Low Water Flow Cooling                        | High          | High             | High                | High        | Low         | Low   | High                     |
| High Air Flow Heating                         | Low           | Low              | Low                 | Low         | High        | Low   | Low                      |
| High Air Flow Cooling                         | Low           | High             | Normal              | High        | Low         | Low   | Normal                   |
| High Water Flow Heating                       | Normal        | Low              | Normal              | High        | Normal      | Normal  | Low                      |
| High Water Flow Cooling                       | Low           | Low              | Low                 | Low         | High        | Normal  | Low                      |
| Low Indoor Air Temperature Heating            | Low           | Low              | Low                 | Normal      | High        | Normal  | Normal/High              |
| Low Indoor Air Temperature Cooling            | Low           | Low              | Low                 | Normal/Low  | High        | Low   | Low                      |
| High Indoor Air Temperature Heating           | High          | High             | High                | Normal/High | Normal/Low  | Low   | Normal                   |
| High Indoor Air Temperature Cooling           | High          | High             | High                | High        | Low         | Low   | High                     |
| Restricted TXV (Check Service Advisory)       | High          | Low              | Normal/Low          | High        | High        | Low   | Low                      |
| Insufficient Compressor (Possible Bad Valves) | Low           | High             | Low                 | High        | Normal/High | Low   | Low                      |
| TXV - Bulb Loss of Charge                     | Low           | Low              | Low                 | High        | High        | Low   | Low                      |
| Scaled Coaxial Heat Exchanger Heating         | Low           | Low              | Low                 | Normal/Low  | High        | Low   | Low                      |
| Scaled Coaxial Heat Exchanger Cooling         | High          | High             | High                | Normal/Low  | Low         | Low   | Low                      |
| Restricted Filter Drier                       |               |                  |                     |             |             | Check temperature difference (delta T) across filter drier. |                          |

7/6/10

## Heat of Extraction/Rejection Data

| Model | GPM  | Heat Of Extraction (HE) |      |      |      | Heat of Rejection (HR) |      |      |      |       |
|-------|------|-------------------------|------|------|------|------------------------|------|------|------|-------|
|       |      | 30°F                    | 50°F | 70°F | 90°F | 30°F                   | 50°F | 70°F | 90°F | 110°F |
| 006   | 1.0  |                         | 4.6  | 6.0  | 7.5  |                        | 10.2 | 9.2  | 13.5 |       |
|       | 1.5  | 3.6                     | 4.7  | 6.1  | 7.7  | 9.8                    | 10.1 | 9.3  | 13.3 | 8.2   |
|       | 2.0  | 3.1                     | 4.8  | 6.2  | 7.8  | 9.8                    | 10.1 | 9.3  | 13.2 | 8.3   |
| 009   | 1.5  |                         | 6.2  | 7.7  | 10.0 |                        | 11.9 | 11.1 | 10.1 |       |
|       | 2.0  | 5.0                     | 6.3  | 7.9  | 10.2 | 11.8                   | 11.9 | 11.0 | 10.1 | 9.3   |
|       | 3.0  | 4.8                     | 6.5  | 8.2  | 10.4 | 11.9                   | 12.0 | 10.9 | 10.2 | 9.4   |
| 012   | 1.5  |                         | 8.0  | 9.9  | 13.3 |                        | 15.2 | 14.6 | 13.6 |       |
|       | 2.5  | 6.6                     | 8.4  | 10.4 | 13.5 | 14.6                   | 15.1 | 14.7 | 13.6 | 11.6  |
|       | 3.5  | 6.4                     | 8.7  | 10.9 | 13.7 | 14.7                   | 15.0 | 14.8 | 13.6 | 11.7  |
| 015   | 2.0  |                         | 9.2  | 11.5 | 13.4 |                        | 18.9 | 18.0 | 17.0 |       |
|       | 3.0  | 7.7                     | 9.5  | 11.8 | 13.6 | 19.2                   | 19.0 | 18.1 | 17.1 | 15.5  |
|       | 4.0  | 7.2                     | 9.9  | 12.1 | 13.8 | 19.3                   | 19.1 | 18.2 | 17.2 | 15.6  |
| 018   | 3.0  |                         | 11.4 | 14.6 | 16.2 |                        | 25.4 | 24.0 | 22.7 |       |
|       | 4.0  | 9.2                     | 11.7 | 14.7 | 16.5 | 25.2                   | 25.1 | 23.6 | 22.7 | 21.7  |
|       | 5.0  | 8.9                     | 11.9 | 14.8 | 16.8 | 25.3                   | 24.9 | 23.3 | 22.9 | 21.8  |
| 024   | 3.0  |                         | 15.9 | 20.2 | 22.5 |                        | 32.6 | 30.8 | 28.8 |       |
|       | 4.5  | 13.2                    | 16.5 | 20.5 | 22.9 | 33.1                   | 33.0 | 31.3 | 28.8 | 26.1  |
|       | 6.0  | 11.9                    | 17.2 | 20.8 | 23.3 | 33.3                   | 33.4 | 31.7 | 29.1 | 26.3  |
| 030   | 4.0  |                         | 19.9 | 25.4 | 31.0 |                        | 39.9 | 37.4 | 34.8 |       |
|       | 6.0  | 16.1                    | 20.7 | 26.5 | 31.5 | 39.0                   | 40.3 | 37.7 | 34.8 | 31.4  |
|       | 8.0  | 14.5                    | 21.6 | 27.6 | 32.0 | 39.2                   | 40.7 | 38.1 | 35.2 | 31.6  |
| 036   | 5.0  |                         | 24.8 | 32.3 | 38.1 |                        | 48.6 | 46.4 | 43.0 |       |
|       | 7.0  | 20.0                    | 25.9 | 33.4 | 38.7 | 46.7                   | 48.7 | 46.8 | 43.1 | 39.3  |
|       | 9.0  | 18.4                    | 27.0 | 34.6 | 39.3 | 46.9                   | 48.8 | 47.1 | 43.5 | 39.6  |
| 042   | 5.0  |                         | 28.1 | 37.3 | 47.4 |                        | 57.0 | 52.9 | 68.6 |       |
|       | 8.0  | 22.8                    | 29.9 | 39.0 | 48.2 | 54.7                   | 57.6 | 53.4 | 68.7 | 44.9  |
|       | 11.0 | 22.1                    | 31.6 | 40.7 | 49.0 | 55.0                   | 58.1 | 54.0 | 69.2 | 45.3  |
| 048   | 6.0  |                         | 33.7 | 44.8 | 58.0 |                        | 69.2 | 64.8 | 59.5 |       |
|       | 9.0  | 26.3                    | 35.4 | 47.3 | 58.9 | 63.9                   | 69.5 | 65.4 | 59.6 | 53.5  |
|       | 12.0 | 25.9                    | 37.1 | 49.8 | 59.9 | 64.2                   | 69.7 | 66.0 | 60.1 | 53.9  |
| 060   | 9.0  |                         | 36.7 | 47.2 | 60.6 |                        | 78.1 | 73.7 | 68.6 |       |
|       | 12.0 | 28.8                    | 38.0 | 49.9 | 61.6 | 74.0                   | 78.4 | 74.1 | 68.7 | 62.2  |
|       | 15.0 | 28.6                    | 39.3 | 52.6 | 62.6 | 74.3                   | 78.6 | 74.4 | 69.2 | 62.6  |
| 070   | 12.0 |                         | 47.7 | 63.7 | 78.4 |                        | 88.8 | 86.1 | 79.5 |       |
|       | 15.0 | 36.0                    | 48.7 | 65.4 | 79.7 | 76.1                   | 87.9 | 86.3 | 79.6 | 72.1  |
|       | 18.0 | 34.5                    | 49.6 | 67.1 | 81.0 | 76.4                   | 87.1 | 86.5 | 80.3 | 72.6  |

Values displayed in MBtu/h

09/26/12

## Reference Calculations

| Heating Calculations:                    | Cooling Calculations:                            |
|--|--|
| $LWT = EWT - \frac{HE}{gpm \times 500}$  | $LWT = EWT + \frac{HR}{gpm \times 500}$          |
| $LAT = EAT + \frac{HC}{cfm \times 1.08}$ | $LAT(DB) = EAT(DB) - \frac{SC}{cfm \times 1.08}$ |
| $TH = HC + HWC$                          | $LC = TC - SC$                                   |
|  | $S/T = \frac{SC}{TC}$                            |

## Legend

### ABBREVIATIONS AND DEFINITIONS:

- cfm = airflow, cubic feet/minute
- EWT = entering water temperature, Fahrenheit
- gpm = water flow in gallons/minute
- WPD = water pressure drop, PSI and feet of water
- EAT = entering air temperature, Fahrenheit (dry bulb/wet bulb)
- HC = air heating capacity, MBtu/h
- TC = total cooling capacity, MBtu/h
- SC = sensible cooling capacity, MBtu/h
- KW = total power unit input, kilowatts
- HR = total heat of rejection, MBtu/h
- HE = total heat of extraction, MBtu/h
- HWC = hot water generator capacity, MBtu/h
- EER = Energy Efficient Ratio = BTU output/Watt input
- COP = Coefficient of Performance = BTU output/BTU input
- LWT = leaving water temperature, °F
- LAT = leaving air temperature, °F
- TH = total heating capacity, MBtu/h
- LC = latent cooling capacity, MBtu/h
- S/T = sensible to total cooling ratio

## Troubleshooting

Should a major problem develop, refer to the following information for possible causes and corrective steps.

### If compressor won't run:

1. The fuse may be open or the circuit breaker is tripped. Check electrical circuits and motor windings for shorts or grounds. Investigate for possible overloading. Replace fuse or reset circuit breakers after fault is corrected.
2. Supply voltage may be too low. Check it with a volt meter.
3. Control system may be faulty. Check control for correct wiring of thermostat or aquastat and check the 24 volt transformer for proper voltage.
4. Wires may be loose or broken. Replace or tighten.
5. The low pressure switch may have tripped due to one or more of the following:
  - a) Heating
    - 1) Plugged heat exchanger on source side
    - 2) Water flow source side - (Low)
    - 3) Water too cold source side
    - 4) Low refrigerant
  - b) Cooling
    - 1) Plugged heat exchanger on load side
    - 2) Water flow load side - (Low)
    - 3) Water too cold load side
    - 4) Low refrigerant
6. The high pressure switch may have tripped due to one or more of the following:
  - a) Heating
    - 1) Plugged heat exchanger on load side
    - 2) Low water flow load side
    - 3) Water too warm load side
  - b) Cooling
    - 1) Plugged heat exchanger on source side
    - 2) Low water flow on source side
    - 3) Water too warm source side
7. The compressor overload protection may be open.
8. The internal winding of the compressor motor may be grounded to the compressor shell. If so, replace the compressor.
9. The compressor winding may be open or shorted. Disconnect power. Check continuity with ohm meter. If the winding is open, replace the compressor.

### If sufficient cooling or heating is not obtained:

1. Check control for improper location or setting.
2. Check for restriction in water flow.
3. Check refrigerant subcooling and superheat for proper refrigerant charge and expansion valve operation.
4. The reversing valve may be defective and creating a bypass of refrigerant. If the unit will not heat, check the reversing valve coil.

### If the unit operation is noisy:

1. Check compressor for loosened mounting bolts. Make sure compressor is floating free on its isolator mounts. Check for tubing contact with the compressor or other surfaces. Readjust it by bending slightly.
2. Check screws on all panels.
3. Check for chattering or humming in the contactor or relays due to low voltage or a defective holding coil. Replace the component.
4. Check for proper installation of vibration absorbing material under the unit.
5. Check for abnormally high discharge pressures.
6. Compressor rotation incorrect

## Refrigerant Systems

To maintain sealed circuit integrity, do not install service gauges unless unit operation appears abnormal. Compare the change in temperature on the air side as well as the water side to the Operating Parameters tables. If the unit's performance is not within the ranges listed, and the airflow and water flow are known to be correct, gauges should then be installed and superheat and subcooling numbers calculated. If superheat and subcooling are outside recommended ranges, an adjustment to the refrigerant charge may be necessary.

**NOTE:** Verify that air and water flow rates are at proper levels before servicing the refrigerant circuit.

# Startup and Troubleshooting Form

Company Name: \_\_\_\_\_ Company Phone No: \_\_\_\_\_  
 Technician Name: \_\_\_\_\_ Date: \_\_\_\_\_  
 Model No: \_\_\_\_\_ Serial No: \_\_\_\_\_  
 Owner's Name: \_\_\_\_\_ Open or Closed Loop: \_\_\_\_\_  
 Installation Address: \_\_\_\_\_ Installation Date: \_\_\_\_\_

Check One

Start up/Check-out for new installation       Troubleshooting      Problem: \_\_\_\_\_

1. FLOW RATE IN GPM (COAXIAL HEAT EXCHANGER)

Water In Pressure: a. \_\_\_\_\_ PSI  
 Water Out Pressure: b. \_\_\_\_\_ PSI  
 Pressure Drop = a - b c. \_\_\_\_\_ PSI  
 Convert Pressure Drop to Flow Rate  
 (refer to *Pressure Drop* table) d. \_\_\_\_\_ GPM

2. TEMPERATURE RISE OR DROP ACROSS COAXIAL HEAT EXCHANGER

|                         | COOLING     | HEATING     |
|-------------------------|-------------|-------------|
| Water In Temperature:   | e. _____ °F | e. _____ °F |
| Water Out Temperature:  | f. _____ °F | f. _____ °F |
| Temperature Difference: | g. _____ °F | g. _____ °F |

3. TEMPERATURE RISE OR DROP ACROSS AIR COIL

|                         | COOLING     | HEATING     |
|-------------------------|-------------|-------------|
| Air In Temperature:     | h. _____ °F | h. _____ °F |
| Air Out Temperature:    | i. _____ °F | i. _____ °F |
| Temperature Difference: | j. _____ °F | j. _____ °F |

4. HEAT OF REJECTION (HR) / HEAT OF EXTRACTION (HE) CALCULATION

HR or HE = Flow Rate x Temperature Difference x Brine Factor\*  
 d. (above) x g. (above) x 485 for Methanol or Environol, 500 for water\*  
 Heat of Extraction (Heating Mode) = \_\_\_\_\_ btu/hr  
 Heat of Rejection (Cooling Mode) = \_\_\_\_\_ btu/hr  
 Compare results to Capacity Data Tables

Note: Steps 5 through 8 need only be completed if a problem is suspected

5. WATTS

|                           | COOLING        | HEATING        |
|---------------------------|----------------|----------------|
| Volts:                    | m. _____ VOLTS | m. _____ VOLTS |
| Total Amps (Comp. + Fan): | n. _____ AMPS  | n. _____ AMPS  |
| Watts = m. x n. x 0.85    | o. _____ WATTS | o. _____ WATTS |

6. CAPACITY

Cooling Capacity = HR. - (o. x 3.413)      p. \_\_\_\_\_ btu/hr  
 Heating Capacity = HE. + (o. x 3.413)      p. \_\_\_\_\_ btu/hr

7. EFFICIENCY

Cooling EER = p. / o.      q. \_\_\_\_\_ EER  
 Heating COP = p. / (o. x 3.413)      q. \_\_\_\_\_ COP

8. SUPERHEAT (S.H.) / SUBCOOLING (S.C.)

|                                 | COOLING      | HEATING      |
|---------------------------------|--------------|--------------|
| Suction Pressure:               | r. _____ PSI | r. _____ PSI |
| Suction Saturation Temperature: | s. _____ °F  | s. _____ °F  |
| Suction Line Temperature:       | t. _____ °F  | t. _____ °F  |
| Superheat = t. - s.             | u. _____ °F  | u. _____ °F  |
| Head Pressure:                  | v. _____ PSI | v. _____ PSI |
| High Pressure Saturation Temp.: | w. _____ °F  | w. _____ °F  |
| Liquid Line Temperature*:       | x. _____ °F  | x. _____ °F  |
| Subcooling = w. - x.            | y. _____ °F  | y. _____ °F  |

\* Note: Liquid line is between the coaxial heat exchanger and the expansion valve in the cooling mode; between the air coil and the expansion valve in the heating mode.

### Startup/Troubleshooting Form

Dealer: \_\_\_\_\_  
 Phone #: \_\_\_\_\_ Date: \_\_\_\_\_  
 Problem: \_\_\_\_\_  
 Model #: \_\_\_\_\_  
 Serial #: \_\_\_\_\_

Controls Info:  
 ABC Version: \_\_\_\_\_  
 AXB Version: \_\_\_\_\_  
 IZ2 Version: \_\_\_\_\_  
 T-Stat Version: \_\_\_\_\_  
 Installed Sensors: \_\_\_\_\_

### COOLING CYCLE ANALYSIS

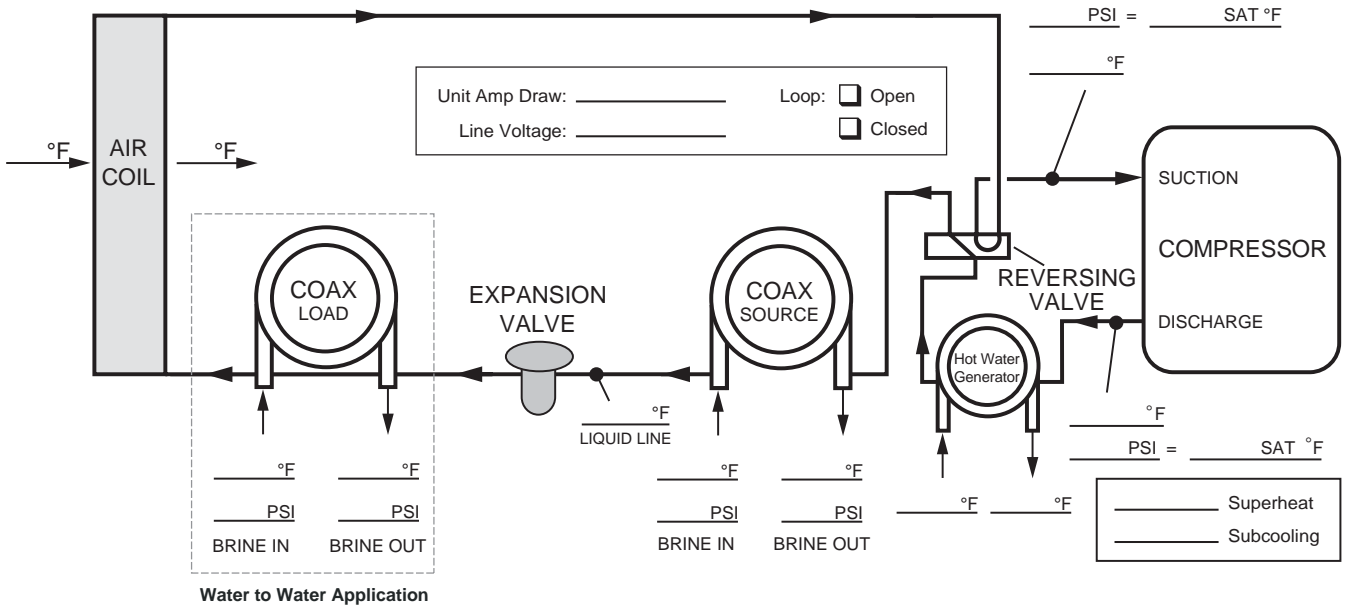

**Heat of Extraction/Rejection = gpm x 500 (485 for water/antifreeze) x ΔT**

**Note: DO NOT** hook up pressure gauges unless there appears to be a performance problem.

### HEATING CYCLE ANALYSIS

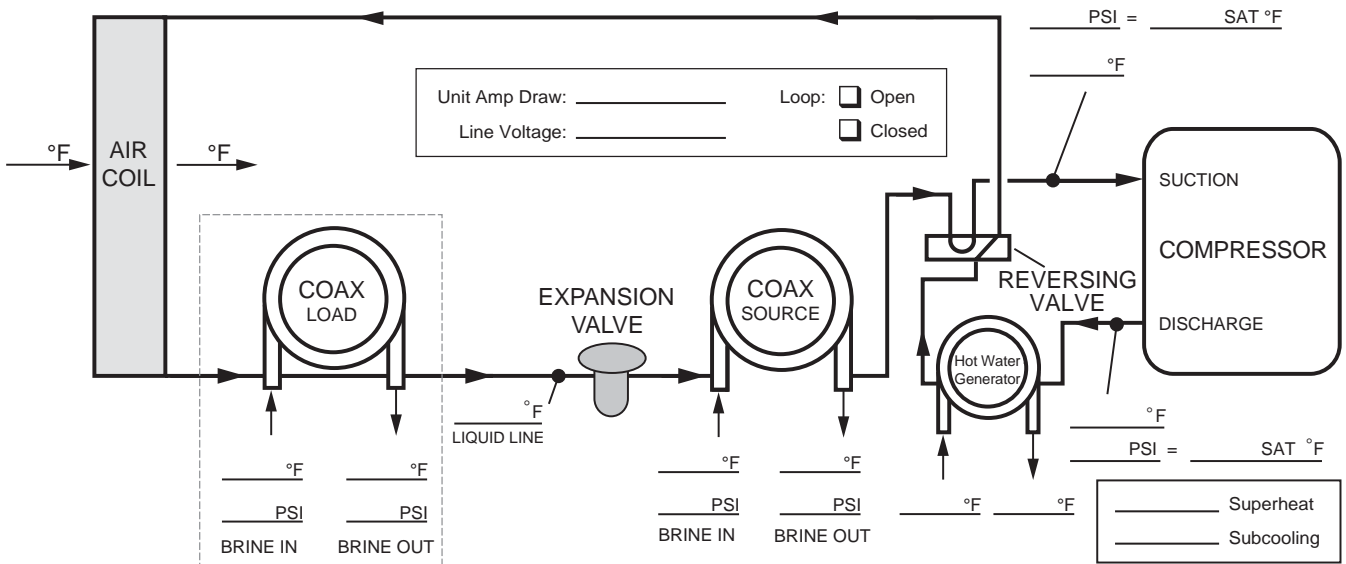



---

## Preventive Maintenance

---

### Water Coil Maintenance

1. Keep all air out of the water. An open loop system should be checked to ensure that the well head is not allowing air to infiltrate the water line. Lines should always be airtight.
2. Keep the system under pressure at all times. It is recommended in open loop systems that the water control valve be placed in the discharge line to prevent loss of pressure during off cycles. Closed loop systems must have positive static pressure.

**NOTE:** On open loop systems, if the installation is in an area with a known high mineral content (125 PPM or greater) in the water, it is best to establish with the owner a periodic maintenance schedule so the coil can be checked regularly. Should periodic coil cleaning be necessary, use standard coil cleaning procedures which are compatible with either the cupronickel or copper water lines. Generally, the more water flowing through the unit the less chance for scaling.

### Other Maintenance

#### Filters

Filters must be clean to obtain maximum performance. They should be inspected monthly under normal operating conditions and be replaced when necessary. Units should never be operated without a filter.

#### Condensate Drain

In areas where airborne bacteria produce a slime in the drain pan, it may be necessary to treat chemically to minimize the problem. The condensate drain can pick up lint and dirt, especially with dirty filters. Inspect twice a year to avoid the possibility of overflow.

#### Blower Motors

Blower motors are equipped with sealed ball bearings and require no periodic oiling.

#### Air Coil

The air coil must be cleaned to obtain maximum performance. Check once a year under normal operating conditions and, if dirty, brush or vacuum (with a brush attachment) clean. Care must be taken not to damage the aluminum fins while cleaning.



**CAUTION: Fin edges are sharp.**

---

## Replacement Procedures

---

### Obtaining Parts

When ordering service or replacement parts, refer to the model number and serial number of the unit as stamped on the serial plate attached to the unit. If replacement parts are required, mention the date of installation of the unit and the date of failure, along with an explanation of the malfunctions and a description of the replacement parts required.

### In-Warranty Material Return

Material may not be returned except by permission of authorized warranty personnel. Contact your local distributor for warranty return authorization and assistance.

# Service Parts - Vertical

|                                   |                                | 006           | 009       | 012       | 015           | 018       | 024       | 030       | 036           | 042           | 048       | 060       | 070       |           |
|-----------------------------------|--------------------------------|---------------|-----------|-----------|---------------|-----------|-----------|-----------|---------------|---------------|-----------|-----------|-----------|-----------|
| Compressor                        | Compressor 208-230/60/1        | 34P653-01     | 34P590-01 | 34P591-01 | 34P592-01     | 34P593-01 | 34P636-01 | 34P637-01 | 34P635-01     | 34P638-01     | 34P639-01 | 34P630-01 | 34P631-01 |           |
|                                   | 265/60/1                       | 34P653-02     | 34P590-02 | 34P591-02 | 34P592-02     | 34P593-02 | 34P636-02 | 34P637-02 | 34P635-02     | Not Available |           |           |           |           |
|                                   | 230/60/3                       | Not Available |           |           |               |           |           | 34P636-03 | 34P637-03     | 34P635-03     | 34P638-03 | 34P639-03 | 34P630-03 | 34P631-03 |
|                                   | 460/60/3                       | Not Available |           |           |               |           |           | 34P636-04 | 34P637-04     | 34P635-04     | 34P638-04 | 34P639-04 | 34P630-04 | 34P631-04 |
|                                   | 575/60/3                       | Not Available |           |           |               |           |           |           |               |               | 34P638-05 | 34P639-05 | 34P630-05 | 34P631-05 |
|                                   | 115/60/1                       | 34P653-09     | 34P590-09 | 34P591-09 | Not Available |           |           |           |               |               |           |           |           |           |
|                                   | Run Capacitor 208-230/60/1     | 16P002D12     | 16P002D17 | 16P002D18 | 16P002D19     |           | 16P002D19 |           | 16P002D20     | 16P002D21     | 16P002D32 | 16P002D23 |           |           |
|                                   | Run Capacitor 265/60/1         | 16P002D27     |           |           | 16P002D30     |           | 16P002D29 |           | 16P002D30     | Not Available |           |           |           |           |
|                                   | Run Capacitor 115/60/1         | 16P002D21     | 16P002D36 |           | Not Available |           |           |           |               |               |           |           |           |           |
|                                   | Sound Jacket                   | 92P504A01     |           |           |               |           |           | 92P523-01 |               |               |           | 92P524-01 |           |           |
| Discharge Muffler                 | Not Available                  |               |           |           |               |           |           |           |               |               | 36P503B02 |           |           |           |
| Variable Speed ECM Motor & Blower | VS ECM Motor 208-230/60/1      | Not Available |           |           |               | 14P515B01 |           |           |               | 14P516B01     |           | 14P517B01 |           |           |
|                                   | VS ECM Motor 265/60/1          | Not Available |           |           |               | 14P515B03 |           |           |               | Not Available |           |           |           |           |
|                                   | VS ECM Motor 230/60/3          | Not Available |           |           |               |           |           | 14P515B01 |               | 14P516B01     |           | 14P517B01 |           |           |
|                                   | VS ECM Motor 460/60/3          | Not Available |           |           |               |           |           | 14P515B03 |               | 14P516B03     |           | 14P517B03 |           |           |
|                                   | VS ECM Blower Housing          | Not Available |           |           |               | 53P512B01 |           |           |               | 53P515B01     |           |           |           |           |
| PSC Motor & Blower                | PSC Motor 115/60/1             | 14P506-03     |           |           | Not Available |           |           |           |               |               |           |           |           |           |
|                                   | PSC Motor 208-230/60/1         | 14P506-02     |           |           | 14P507B01     | 14P508B01 | 14P509B01 | 14P510B01 | 14P511B01     | 14P512B01     | 14P514B01 |           |           |           |
|                                   | PSC Motor 265/60/1             | 14P506-02     |           |           | 14P507B02     | 14P508B02 | 14P509B02 | 14P510B02 | Not Available |               |           |           |           |           |
|                                   | PSC Motor 230/60/3             | Not Available |           |           |               |           |           | 14P508B01 | 14P509B01     | 14P510B01     | 14P511B01 | 14P512B01 | 14P514B01 |           |
|                                   | PSC Motor 460/60/3             | Not Available |           |           |               |           |           | 14P508B03 | 14P509B03     | 14P510B03     | 14P511B02 | 14P512B02 | 14P514B02 |           |
|                                   | PSC Motor 575/60/3             | Not Available |           |           |               |           |           |           |               |               | 14P511B03 | 14P512B03 | 14P514B03 |           |
|                                   | PSC Blower & Housing           |               |           |           |               | 53P512B01 |           |           |               | 53P517-02     |           | 53P515B01 |           |           |
| 5-Speed ECM Motor & Blower        | 5-Speed ECM Motor 208-230/60/1 | Not Available |           |           | 14S536-18     | 14S536-01 | 14S536-02 | 14S536-03 | 14S537-01     | 14S537-02     | 14S537-03 | 14S537-03 |           |           |
|                                   | 5-Speed ECM Motor 277/60/1     | Not Available |           |           | 14S536-19     | 14S536-02 | 14S536-07 | 14S536-08 | Not Available |               |           |           |           |           |
|                                   | 5-Speed ECM Motor 230/60/3     | Not Available |           |           |               |           |           | 14P536-01 | 14S536-02     | 14S536-03     | 14S537-01 | 14S537-02 | 14S537-03 | 14S537-03 |
|                                   | 5-Speed ECM Motor 460/60/3     | Not Available |           |           |               |           |           | 14S536-03 | 14S536-10     | 14S536-11     | 14S537-04 | 14S537-05 | 14S537-06 | 14S537-06 |
|                                   | 5-Speed ECM Blower & Housing   | Not Available |           |           |               | 53P512B01 |           |           |               | 53P515B01     |           |           |           |           |
| Refrigeration Components          | Air Coil                       | 61P723-41     |           |           | 61P704-41     |           | 61P713-41 |           | 61P705-41     | 61P711-41     |           | 61P706-41 | 61P715-41 |           |
|                                   | Coax (Copper)                  | 62P587-01     | 62P591-01 | 62P586-01 | 62P586-01     | 62P586-01 | 62P586-01 | 62P572-01 | 62P566-01     |               | 62P568-01 | 62P573-01 | 62P574-01 |           |
|                                   | TXV                            | 33P605-19     |           |           | 33P605-16     |           |           | 33P605-02 |               | 33P605-10     |           | 33P608-10 | 33P605-13 |           |
|                                   | Reversing Valve                | 33P502-05     | 33P502-05 | 33P502-05 | 33P505-04     |           |           |           | 33P506-04     |               |           | 33P503-05 | 33P526-04 |           |
|                                   | Filter Drier                   | 36P500B01     |           |           |               |           |           |           |               |               |           |           |           |           |
| Controls                          | Transformer 115/60/1           | 15P008B02     |           |           | Not Available |           |           |           |               |               |           |           |           |           |
|                                   | Transformer 208-230/60/1       | 15P501B01     |           |           |               |           |           |           |               |               |           |           |           |           |
|                                   | Transformer 265/60/1           | 15P507B01     |           |           |               |           |           |           |               | Not Available |           |           |           |           |
|                                   | Transformer 230/60/3           | Not Available |           |           |               |           |           | 15P501B01 |               |               |           |           |           |           |
|                                   | Transformer 460/60/3           | Not Available |           |           |               |           |           | 15P505B01 |               |               |           |           |           |           |
|                                   | Transformer 575/60/3           | Not Available |           |           |               |           |           |           |               |               | 15P506B01 |           |           |           |
|                                   | Phase Guard                    | Not Available |           |           |               |           |           |           |               |               |           | 19P541A06 |           |           |
| Sensors & Safeties                | High Pressure Switch           | 35P506B02     |           |           |               |           |           |           |               |               |           |           |           |           |
|                                   | Low Pressure Switch            | 35P506B01     |           |           |               |           |           |           |               |               |           |           |           |           |

Part numbers subject to change

# Service Parts - Horizontal

|                                   |                                | 006           | 009       | 012       | 015           | 018       | 024           | 030       | 036           | 042           | 048       | 060       | 070       |  |
|-----------------------------------|--------------------------------|---------------|-----------|-----------|---------------|-----------|---------------|-----------|---------------|---------------|-----------|-----------|-----------|--|
| Compressor                        | Compressor 208-230/60/1        | 34P653-01     | 34P590-01 | 34P591-01 | 34P592-01     | 34P593-01 | 34P636-01     | 34P637-01 | 34P635-01     | 34P638-01     | 34P639-01 | 34P630-01 | 34P631-01 |  |
|                                   | 265/60/1                       | 34P653-02     | 34P590-02 | 34P591-02 | 34P592-02     | 34P593-02 | 34P636-02     | 34P637-02 | 34P635-02     | Not Available |           |           |           |  |
|                                   | 230/60/3                       | Not Available |           |           |               |           | 34P636-03     | 34P637-03 | 34P635-03     | 34P638-03     | 34P639-03 | 34P630-03 | 34P631-03 |  |
|                                   | 460/60/3                       | Not Available |           |           |               |           | 34P636-04     | 34P637-04 | 34P635-04     | 34P638-04     | 34P639-04 | 34P630-04 | 34P631-04 |  |
|                                   | 575/60/3                       | Not Available |           |           |               |           |               |           |               | 34P638-05     | 34P639-05 | 34P630-05 | 34P631-05 |  |
|                                   | 115/60/1                       | 34P653-09     | 34P590-09 | 34P591-09 | Not Available |           |               |           |               |               |           |           |           |  |
|                                   | Run Capacitor 208-230/60/1     | 16P002D12     | 16P002D17 | 16P002D18 | 16P002D19     | 16P002D19 | 16P002D20     | 16P002D21 | 16P002D32     | 16P002D23     |           |           |           |  |
|                                   | Run Capacitor 265/60/1         | 16P002D27     |           |           | 16P002D30     | 16P002D29 | Not Available |           |               |               |           |           |           |  |
|                                   | Run Capacitor 115/60/1         | 16P002D21     | 16P002D36 |           | Not Available |           |               |           |               |               |           |           |           |  |
|                                   | Sound Jacket                   | 92P504A01     |           |           |               |           | 92P523-01     |           |               |               |           | 92P524-01 |           |  |
| Discharge Muffler                 | Not Available                  |               |           |           |               |           |               |           |               |               | 36P503B02 |           |           |  |
| Variable Speed ECM Motor & Blower | VS ECM Motor 208-230/60/1      | Not Available |           |           |               | 14P515B01 |               |           |               | 14P516B01     |           | 14P517B01 |           |  |
|                                   | VS ECM Motor 265/60/1          | Not Available |           |           |               | 14P515B03 |               |           |               | Not Available |           |           |           |  |
|                                   | VS ECM Motor 230/60/3          | Not Available |           |           |               |           | 14P515B01     |           |               | 14P516B01     |           | 14P517B01 |           |  |
|                                   | VS ECM Motor 460/60/3          | Not Available |           |           |               |           | 14P515B03     |           |               | 14P516B03     |           | 14P517B03 |           |  |
|                                   | VS ECM Blower Housing          | Not Available |           |           |               | 53P512B01 |               |           |               | 53P515B01     |           |           |           |  |
| PSC Motor & Blower                | PSC Motor 115/60/1             | 14P506-03     |           |           | Not Available |           |               |           |               |               |           |           |           |  |
|                                   | PSC Motor 208-230/60/1         | 14P506-02     |           |           | 14P507B01     | 14P508B01 | 14P509B01     | 14P510B01 | 14P511B01     | 14P512B01     | 14P514B01 |           |           |  |
|                                   | PSC Motor 265/60/1             | 14P506-02     |           |           | 14P507B02     | 14P508B02 | 14P509B02     | 14P510B02 | Not Available |               |           |           |           |  |
|                                   | PSC Motor 230/60/3             | Not Available |           |           |               |           | 14P508B01     | 14P509B01 | 14P510B01     | 14P511B01     | 14P512B01 | 14P514B01 |           |  |
|                                   | PSC Motor 460/60/3             | Not Available |           |           |               |           | 14P508B03     | 14P509B03 | 14P510B03     | 14P511B02     | 14P512B02 | 14P514B02 |           |  |
|                                   | PSC Motor 575/60/3             | Not Available |           |           |               |           |               |           |               | 14P511B03     | 14P512B03 | 14P514B03 |           |  |
|                                   | PSC Blower & Housing           |               |           |           |               | 53P512B01 |               |           |               | 53P517-02     |           | 53P515B01 |           |  |
| 5-Speed ECM Motor & Blower        | 5-Speed ECM Motor 208-230/60/1 | Not Available |           |           | 14S536-18     | 14S536-01 | 14S536-02     | 14S536-03 | 14S537-01     | 14S537-02     | 14S537-03 | 14S537-03 |           |  |
|                                   | 5-Speed ECM Motor 277/60/1     | Not Available |           |           | 14S536-19     | 14S536-06 | 14S536-07     | 14S536-08 | Not Available |               |           |           |           |  |
|                                   | 5-Speed ECM Motor 230/60/3     | Not Available |           |           |               |           | 14P536-01     | 14S536-02 | 14S536-03     | 14S537-01     | 14S537-02 | 14S537-03 | 14S537-03 |  |
|                                   | 5-Speed ECM Motor 460/60/3     | Not Available |           |           |               |           | 14S536-09     | 14S536-10 | 14S536-11     | 14S537-04     | 14S537-05 | 14S537-06 | 14S537-06 |  |
|                                   | 5-Speed ECM Blower & Housing   | Not Available |           |           |               | 53P512B01 |               |           |               | 53P515B01     |           |           |           |  |
| Refrigeration Components          | Air Coil                       | 61P726-41     | 61P726-41 | 61P726-41 | 61P704-41     |           | 61P712-41     |           | 61P707-41     | 61P708-41     |           | 61P709-41 | 61P710-41 |  |
|                                   | Coax (Copper)                  | 62P587-01     | 62P591-01 | 62P586-01 | 62P586-01     | 62P586-01 | 62P586-01     | 62P572-01 | 62P566-01     |               | 62P568-01 | 62P573-01 | 62P574-01 |  |
|                                   | TXV                            | 33P605-19     |           |           | 33P605-16     |           |               | 33P605-02 |               | 33P605-10     |           | 33P608-10 | 33P605-13 |  |
|                                   | Reversing Valve                | 33P502-05     | 33P502-05 | 33P502-05 | 33P505-04     |           |               |           | 33P506-04     |               | 33P503-05 | 33P526-04 |           |  |
|                                   | Filter Drier                   | 36P500B01     |           |           |               |           |               |           |               |               |           | 36P500B02 |           |  |
| Controls                          | Transformer 115/60/1           | 15P008B02     |           |           | Not Available |           |               |           |               |               |           |           |           |  |
|                                   | Transformer 208-230/60/1       | 15P501B01     |           |           |               |           |               |           |               |               |           |           |           |  |
|                                   | Transformer 265/60/1           | 15P507B01     |           |           |               |           |               |           | Not Available |               |           |           |           |  |
|                                   | Transformer 230/60/3           | Not Available |           |           |               |           | 15P501B01     |           |               |               |           |           |           |  |
|                                   | Transformer 460/60/3           | Not Available |           |           |               |           | 15P505B01     |           |               |               |           |           |           |  |
|                                   | Transformer 575/60/3           | Not Available |           |           |               |           |               |           |               | 15P506B01     |           |           |           |  |
| Phase Guard                       | Not Available                  |               |           |           |               | 19P541A06 |               |           |               |               |           |           |           |  |
| Sensors & Safeties                | High Pressure Switch           | 35P506B02     |           |           |               |           |               |           |               |               |           |           |           |  |
|                                   | Low Pressure Switch            | 35P506B01     |           |           |               |           |               |           |               |               |           |           |           |  |

Part numbers subject to change.

## Notes

---

# Revision Guide

---

| <b>Pages:</b> | <b>Description:</b>                        | <b>Date:</b> | <b>By:</b> |
|---------------|--|--------------|------------|
| All           | Updated with CuproNickel Water Coil Option | 20 May 2014  | DS         |
| All           | Updated with All-Aluminum Air Coils        | 09 Oct 2013  | DS         |
| All           | First Published                            | 08 Apr 2013  | DS         |







Product: **Arbor Base Series**  
Type: Geothermal/Water Source Heat Pumps  
Size: 0.5-6 Ton

Document Type: Installation Manual  
Part Number: IM1201AZA  
Release Date: 05/14