

ASTON LOW SILL SERIES

COMMERCIAL

Water Source/Geothermal Heat Pump

- R-410A Refrigerant
- Commercial 0.75-6 Ton

Installation Information

Water Piping Connections

Hot Water Connections

Electrical

Startup Procedures

Troubleshooting

Preventive Maintenance



GEOSTAR

Table of Contents

| | |
|-------------------------------------------------|----|
| Model Nomenclature | 4 |
| General Installation Information | 5 |
| Dimensional Data | 6 |
| Physical Data | 10 |
| Installation Steps | 11 |
| System Cleaning and Flushing | 15 |
| Open Loop Ground Water Systems | 16 |
| Electrical Connections | 17 |
| Electrical Data | 18 |
| Blower Performance Data | 19 |
| Wiring Schematics | 20 |
| Controls | 26 |
| Unit Startup Notes | 34 |
| Unit Startup Checklist/Unit Startup Steps | 35 |
| Operating Parameters | 36 |
| Operating Limits | 36 |
| Pressure Drop | 37 |
| Compressor and Thermistor Resistance | 37 |
| Refrigerant Circuit Guideline | 38 |
| Heat of Extraction/Rejection Data | 39 |
| Reference Calculations and Legend | 39 |
| Startup/Troubleshooting Form | 40 |
| Preventive Maintenance | 41 |
| Replacement Procedures | 41 |
| Service Parts | 42 |
| Revision Guide | 44 |

Model Nomenclature

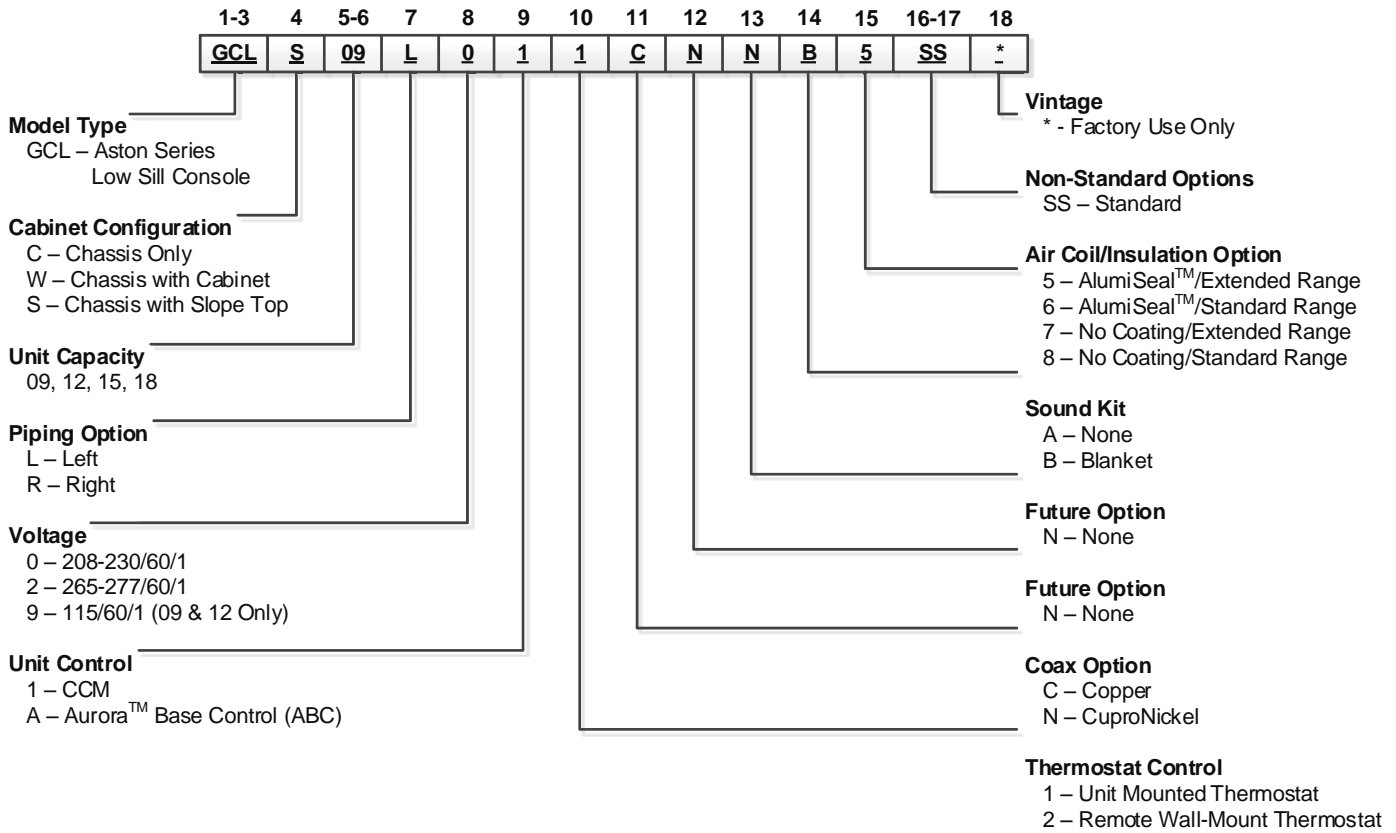

NOTES: Chassis only available with left piping option.
09-12 only available with PSC blower.
15-18 only available with 3-Speed ECM blower.



All Aston Series product is Safety listed under UL1995 thru ETL and performance listed with AHRI in accordance with standard 13256-1.

General Installation Information

Safety Considerations



WARNING: Before performing service or maintenance operations on a system, turn off main power switches to the indoor unit. If applicable, turn off the accessory heater power switch. Electrical shock could cause personal injury.

Installing and servicing heating and air conditioning equipment can be hazardous due to system pressure and electrical components. Only trained and qualified service personnel should install, repair or service heating and air conditioning equipment. Untrained personnel can perform the basic maintenance functions of cleaning coils and cleaning and replacing filters. All other operations should be performed by trained service personnel. When working on heating and air conditioning equipment, observe precautions in the literature, tags and labels attached to the unit and other safety precautions that may apply.

Follow all safety codes. Wear safety glasses and work gloves. Use a quenching cloth for brazing operations and have a fire extinguisher available.

Moving and Storage

Move units in the normal "up" orientation. Do not stack units. When the equipment is received, all items should be carefully checked against the bill of lading to be sure all crates and cartons have been received. Examine units for shipping damage, removing the units from the packaging if necessary. Units in question should also be internally inspected. If any damage is noted, the carrier should make the proper notation on the delivery receipt, acknowledging the damage.

Water Piping

The proper water flow must be provided to each unit whenever the unit operates. To assure proper flow, use pressure/temperature ports to determine the flow rate. These ports should be located at the supply and return water connections on the unit. The proper flow rate cannot be accurately set without measuring the water pressure drop through the refrigerant-to-water heat exchanger.

All source water connections on commercial units are fittings that accept a male pipe thread (MPT). Insert the connectors by hand, then tighten the fitting with a wrench to provide a leakproof joint. When connecting to an open loop (groundwater) system, thread any copper MPT fitting into the connector and tighten in the same manner as described above.

Refrigerant Systems

To maintain sealed circuit integrity, do not install service gauges unless unit operation appears abnormal. Compare the change in temperature on the air side as well as the water side to the Unit Operating Parameters tables. If the unit's performance is not within the ranges listed, and the airflow and water flow are known to be correct, gauges should then be installed and superheat and subcooling numbers calculated. If superheat and subcooling are outside recommended ranges, an adjustment to the refrigerant charge may be necessary.

Dimensional Data - Flat Top Cabinet

GCLW09-18

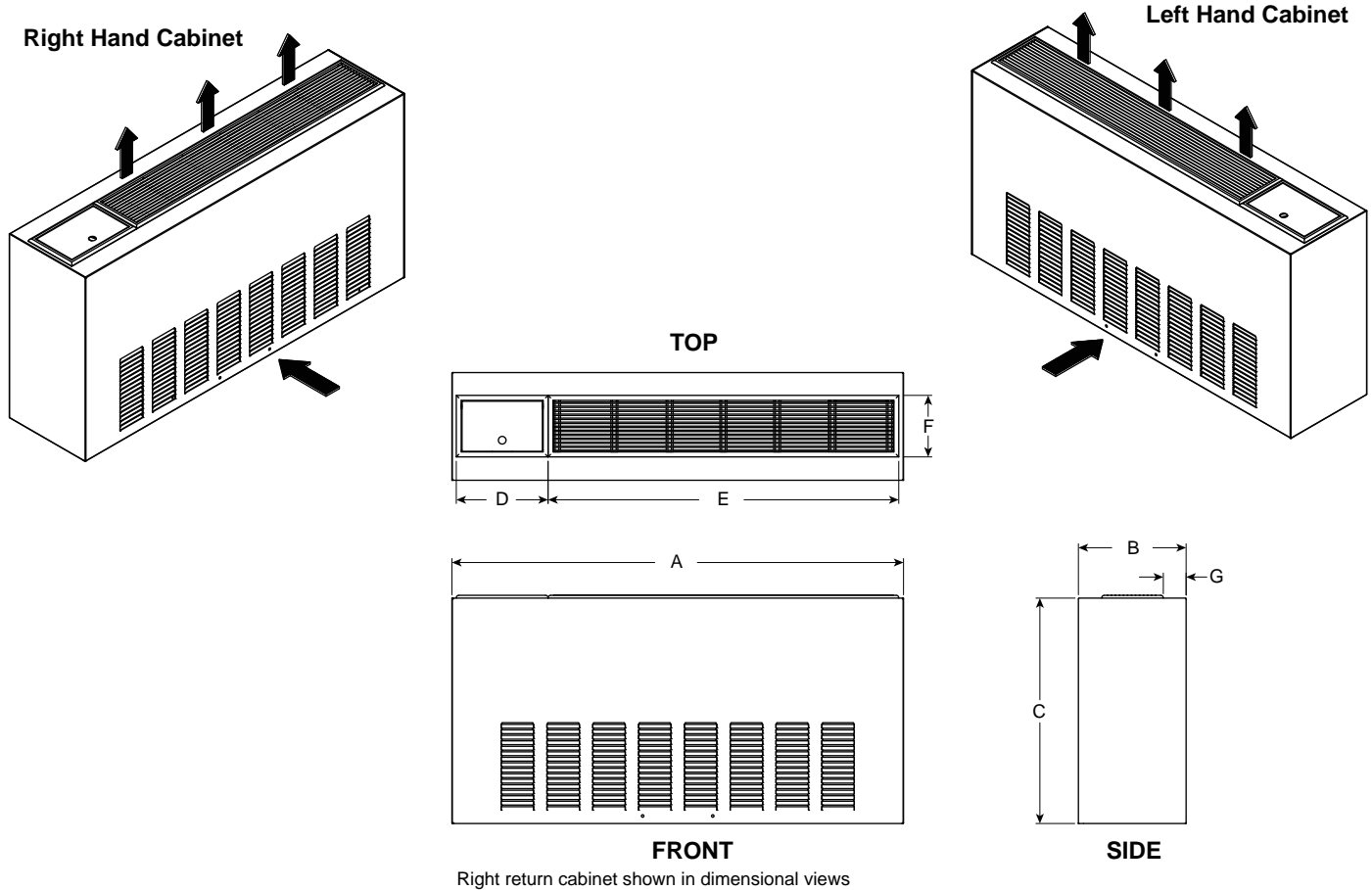

| Flat Top Configuration | | Overall Cabinet | | | Grille | | | |
|------------------------|-----|-----------------|-------|--------|------------|---------------|--------------|-----|
| | | A | B | C | D | E | F | G |
| | | Width | Depth | Height | Grille Lid | Grille Length | Grille Width | |
| 09-12 | in. | 45.1 | 10.8 | 22.5 | 9.2 | 35.0 | 6.1 | 2.3 |
| | cm. | 114.6 | 27.4 | 57.2 | 23.4 | 88.9 | 15.6 | 5.8 |
| 15-18 | in. | 50.0 | 12.8 | 22.5 | 9.2 | 35.0 | 6.1 | 3.3 |
| | cm. | 127.0 | 32.4 | 57.2 | 23.4 | 88.9 | 15.6 | 8.3 |

Dimensional Data - Slope Top Cabinet

GCLS09-18

Right Hand Cabinet

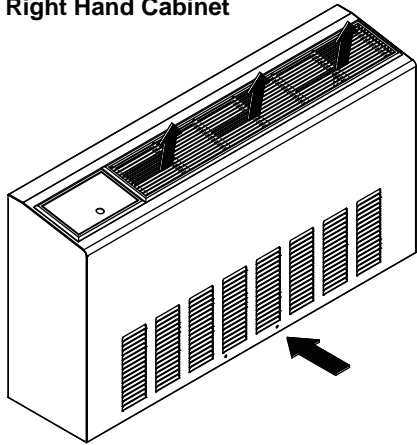

Left Hand Cabinet

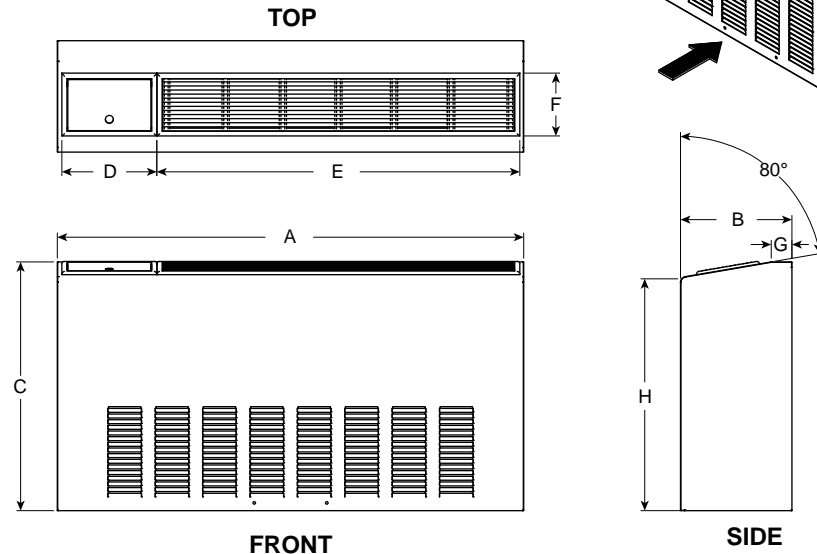
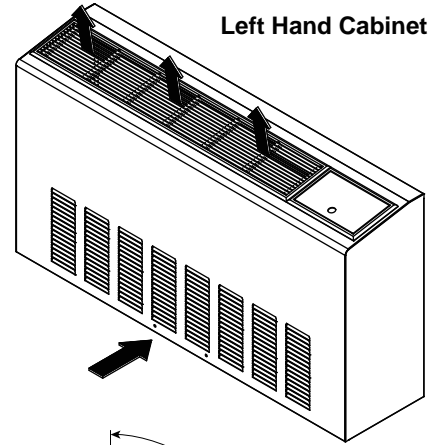

Right return cabinet shown in dimensional views

| Slope Top Configuration | | Overall Cabinet | | | Grille | | | | |
|-------------------------|-----|-----------------|-------|--------|------------|---------------|--------------|-----|------|
| | | A | B | C | D | E | F | G | H |
| | | Width | Depth | Height | Grille Lid | Grille Length | Grille Width | | |
| 09-12 | in. | 45.1 | 10.8 | 24.0 | 9.2 | 35.0 | 6.1 | 2.0 | 22.4 |
| | cm. | 114.6 | 27.4 | 61.0 | 23.4 | 88.9 | 15.6 | 5.1 | 56.9 |
| 15-18 | in. | 50.0 | 12.8 | 24.0 | 9.2 | 35.0 | 6.1 | 2.0 | 22.5 |
| | cm. | 127.0 | 32.4 | 61.0 | 23.4 | 88.9 | 15.6 | 5.1 | 57.2 |

Dimensional Data - Chassis

GCLC09-12

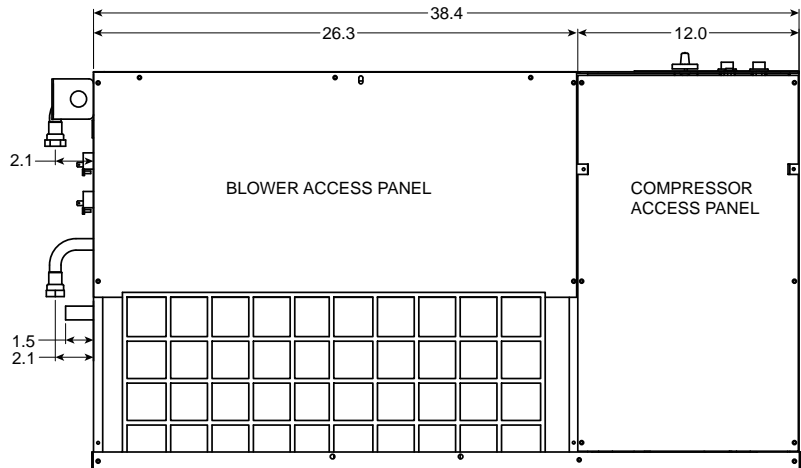
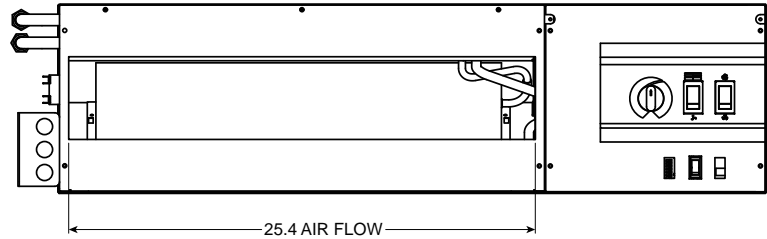
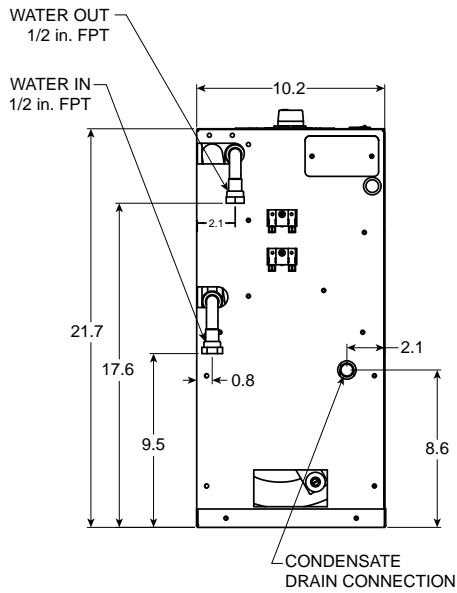

GCLC15-18

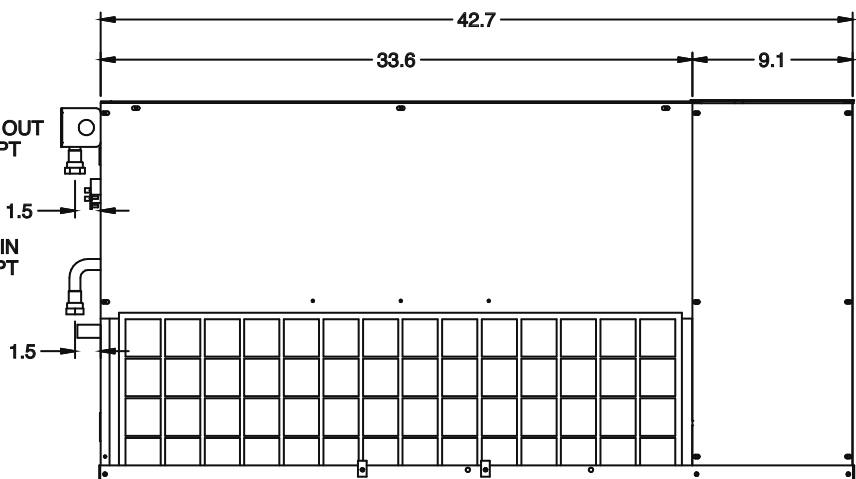
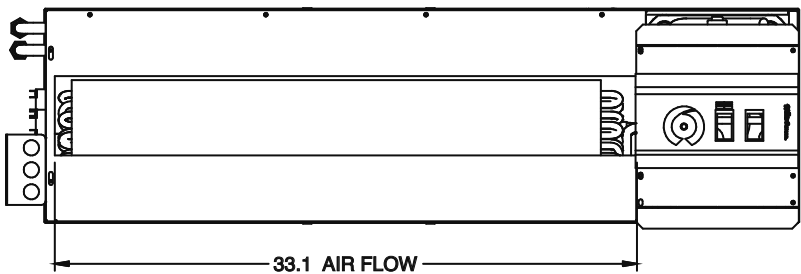
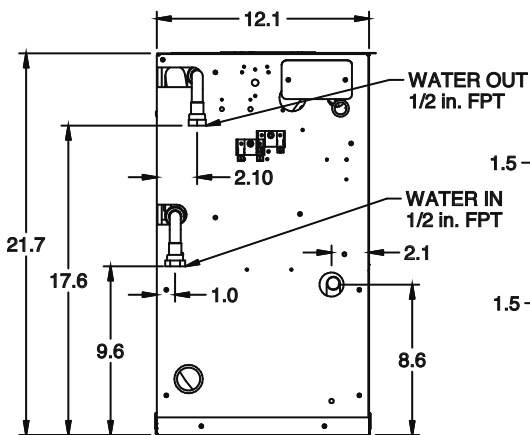

Dimensional Data - Controls Detail: Flat Top Chassis

Left Return

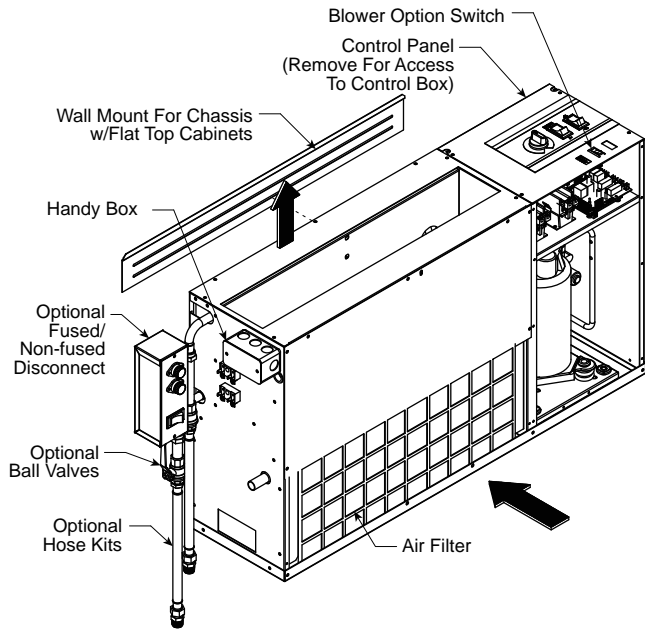

Right Return

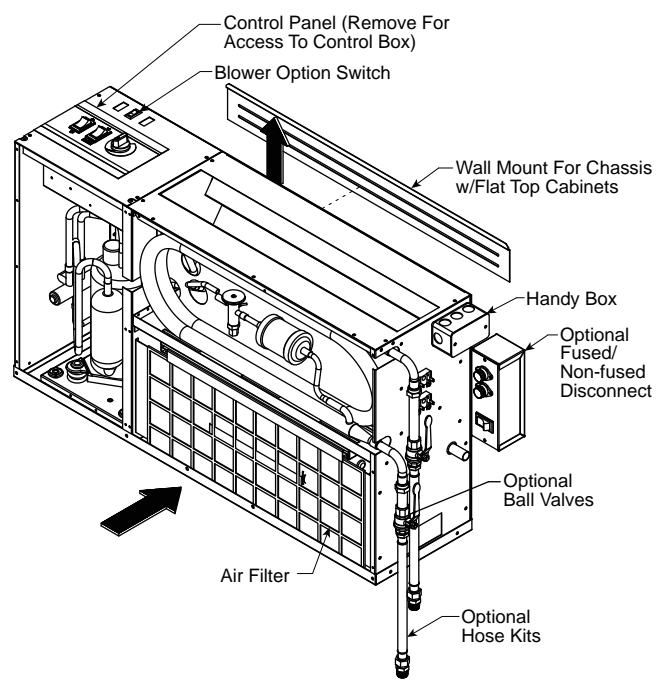

Dimensional Data - Controls Detail: Slope Top Chassis

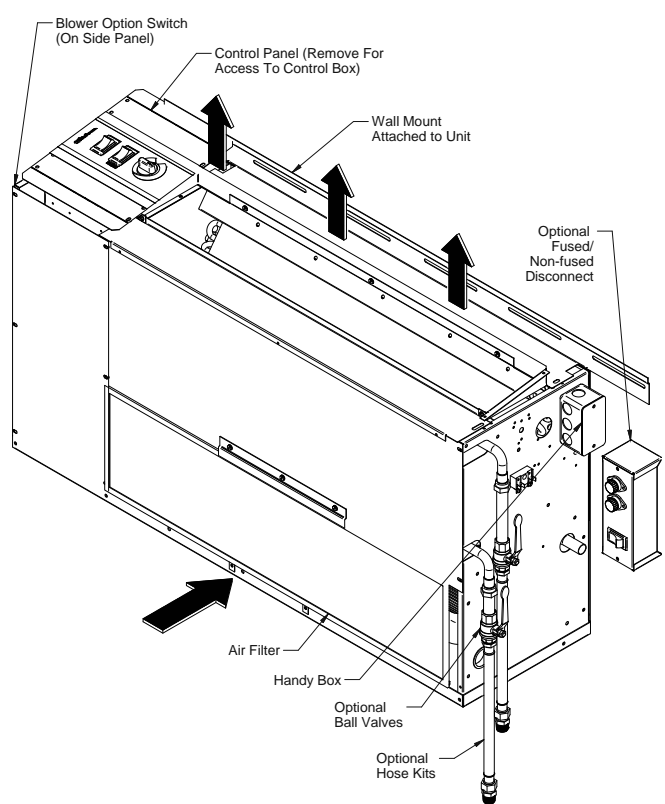
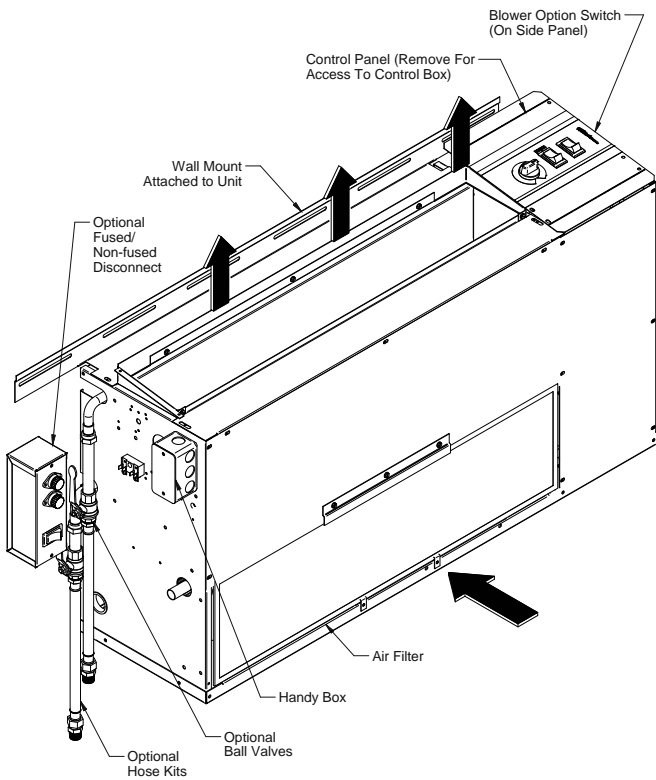

Physical Data

| Model | | Console | | | |
|-------------------------------------------------------------|--------------|----------------------------|----------------------------|--------------------------|--------------------------|
| | | 09 | 12 | 15 | 18 |
| Compressor (1 each) | | Rotary | | | |
| Factory Charge R-410A, oz [kg] | | 27 [0.77] | 27 [0.77] | 36 [1.02] | 34 [1.0] |
| Blower Motor & Blower | | | | | |
| Blower Motor Type/Speeds | 3-Spd ECM | N/A | | 3 Speeds | |
| Blower Motor - hp [W] | 3-Spd ECM | N/A | | 1/4 [186] | 1/4 [186] |
| Blower Wheel Size (Dia x W), in. [mm] | 3-Spd ECM | N/A | | 6.0 x 6.5 [152 x 165] | 6.0 x 6.5 [152 x 165] |
| Blower Motor Type/Speeds | PSC | 2 Speeds | | N/A | |
| Blower Motor - hp [W] | PSC | 1/16 [44.7] | 1/16 [44.7] | N/A | |
| Blower Wheel Size (Dia x W), in. [mm] | PSC | 5.75 x 5.50 [146 x 140] | 5.75 x 5.50 [146 x 140] | N/A | |
| Coax and Water Piping | | | | | |
| Water Connection Size - FPT - in [mm] | | 1/2 [12.7] | 1/2 [12.7] | 1/2 [12.7] | 1/2 [12.7] |
| Coax & Piping Water Volume - gal [l] | | 0.15 [0.6] | 0.18 [0.7] | 0.15 [0.6] | 0.18 [0.7] |
| Air Coil | | | | | |
| Air Coil Dimensions (H x W), in. [mm] | | 8 x 22 [203 x 559] | 8 x 22 [203 x 559] | 8 x 30 [203 x 762] | 8 x 30 [203 x 762] |
| Air Coil Total Face Area, ft ² [m ²] | | 1.2 [0.114] | 1.2 [0.114] | 1.7 [0.16] | 1.7 [0.16] |
| Air Coil Tube Size, in [mm] | | 3/8 [9.5] | 3/8 [9.5] | 3/8 [9.5] | 3/8 [9.5] |
| Air Coil Number of Rows | | 3 | 3 | 4 | 4 |
| Filter Standard - Throwaway, in [mm] | | 23 x 9.6 [584 x 244] | 23 x 9.6 [584 x 244] | 32 x 9.6 [813 x 244] | 32 x 9.6 [813 x 244] |
| Weight - Packaged, lb [kg] | | 200 [91] | 205 [93] | 215 [98] | 220 [100] |

12/13/13

Installation Steps

Step 1: Unpack Equipment and Inspect for Damage

Step 2: Determine Equipment Location

- Choose level flooring surface (Correctable with shims. Do not pitch towards drain.)
- Location of wall support and fasteners required to secure chassis backplate.
- Easy access for both installation and service.
- Consider availability and ease of wiring, water piping and condensate drain.
- No obstructions to block airflow in front of the unit.

Step 3: Mark Unit Position

- Ensure that floor is level. If shims are required, make sure that the entire compressor compartment area is uniformly shimmed and that the backplate mounting height is increased by the thickness of the shims used.
- Position backplate in desired equipment location. To further reduce the operating sound level of the unit, 1/8-inch thick rubber matting may be placed under the chassis to eliminate vibration on hard flooring surfaces. (Make sure back plate is level).
- Mark and cut floor or wall penetrations for electrical wiring, water and condensate piping.

Optional Electrical Disconnect and Motorized Outside Air Damper

- Mark and cut wall penetrations for field fabricated outside air duct sleeve.
- Align mounting holes with backplate and attach with screws supplied.

Figure 1

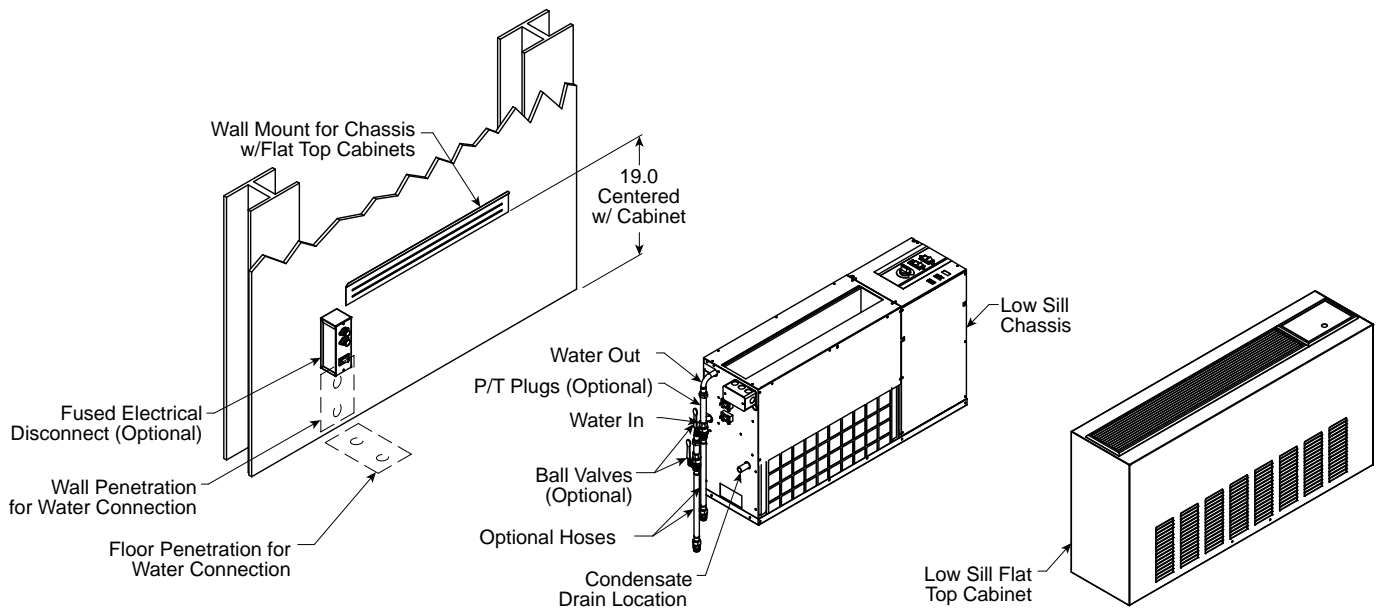

Installation Steps cont.

Step 4: Provide Water and Condensate Drain Connections

- A two-pipe reverse return piping configuration is recommended as it equalizes the piping circuit lengths and delivers even water flow to each unit. A direct return piping configuration may be used, but it may be difficult to achieve and maintain proper water flow to the units.
- An air vent must be installed in the water distribution system.
- The supply and return water piping should be run through the wall or floor penetration and terminate with a ball valve. The piping material used must comply with all local codes.
- Refer to: **System Cleaning and Flushing procedures.**

Pipe Locations

Figure 2

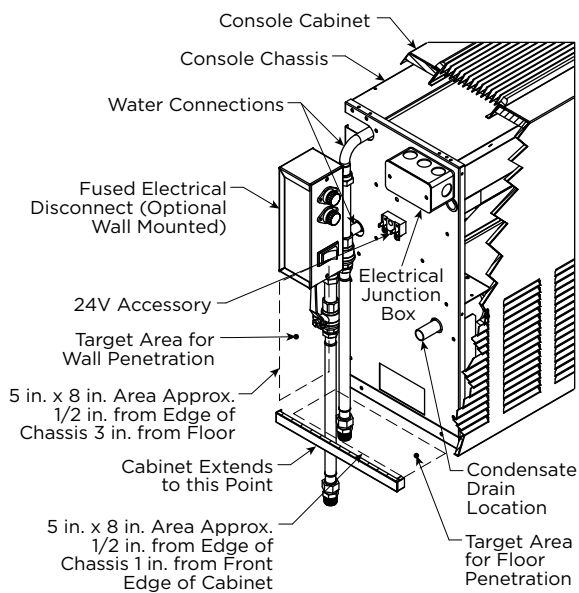

Installation Steps cont.

Step 5: Provide Line Voltage Wiring

- Check unit data plate located on control side of chassis for ampacity and fuse size.
- Remove electrical knockouts from chassis backplate.
- Run line voltage wiring through knockout and secure wiring to backplate or disconnect.

Step 6: Chassis Installation

- Level and secure backplate to wall.
- Position the chassis against back plate. Drive (2) screws through holes in lip of backplate into top flange of chassis.

Step 7: Final Electrical Connection

- Install flexible electrical conduit between the backplate or electrical disconnect and the unit mounted junction box.
- Make final wiring connections in disconnect and junction box, taking care to replace all covers when done. Wiring must conform to NEC and/or all local codes. **Refer to Electrical Data.**

NOTE: It is necessary to make final wiring connections prior to securing unit chassis to back plate on right-hand piping models with electrical disconnect.

Step 8: Final Water Connection

- For ease of installation and sound attenuation, high pressure (recommended) flexible hoses with a swivel fitting should be provided. Apply Teflon® tape or sealant compound to threaded hose fittings.
- Combination shut-off/balancing valves should be installed on both the supply and return water lines of the unit.
- Flow control valves should be installed on the water discharge line.
- It is recommended that P/T ports be installed on the supply and return water lines.

Step 9: Set Unit Controls

- Locate the "continuous fan/cycle fan" switch within the electrical compartment of the chassis and set to desired position. (Remote wall thermostat units do not use this optional switch.)
- Optional Control Settings-
Remote Thermostat - Run low voltage wiring from unit to the desired thermostat location.
Mount and wire thermostat according to manufacturer's recommendations.

Step 10: Secure the Cabinet Cover

- Position and lower cabinet over unit chassis. Apply pressure to the front of the cabinet to ensure that the back lip of the cabinet hooks over the tabs provided on the backplate.
- Secure cabinet to chassis with mounting screws provided.

Step 11: Perform Final Unit Check

- Measure the pressure drop across the water coil and monitor water or air temperatures in both heating and cooling modes. The measured values should fall within the acceptable ranges shown in the **Startup Performance table.**

Installation Steps cont.

Field Converting Console

Chassis is normally configured with controls on right end and piping on left end (see Figure 3 top view). In this position panel number 1 would be positioned against wall or back plate. Unit may also be turned 180° against wall or back plate. In this position controls will be on left end and piping on right end panel number 2 would be positioned against wall or back plate. Chassis must be enclosed with an approved cabinet enclosure.

1. Remove 4 screws from front kick panel on cabinet.
2. Remove cabinet from chassis by lifting and sliding cabinet straight up.
3. Remove grille assembly from cabinet by removing 4 screws from brackets located on the bottom of the grille and door assemblies.
4. Replace grille/door assemblies into cabinet repositioning pieces 1, 2, and 3 into the locations directly opposite the original positions. Secure by replacing mounting brackets. (Note: Be sure that louvers on the grille assembly are facing the proper direction when replacing the grille section.)
5. Replace grille/frame assembly into cabinet, and secure by replacing mounting brackets.
6. Replace cabinet by sliding it down over the top of the chassis.
7. Remove tab on leg that extends into return air opening. When the grille side of the cabinet is flat against chassis there will be 4 holes that line up in the leg section. Only use 1 hole for alignment for opposite side of grille. (Note: The tab can be removed by twisting back and forth until it breaks off.)
8. Remove plastic strip from tab and replace on rough edge that the tab was removed from.
9. Replace screws in front kick panel to secure cabinet to chassis.
10. Mount filter bracket in designated opening area. (Note: The filter bracket will only fit in one direction if cabinet is installed properly.)

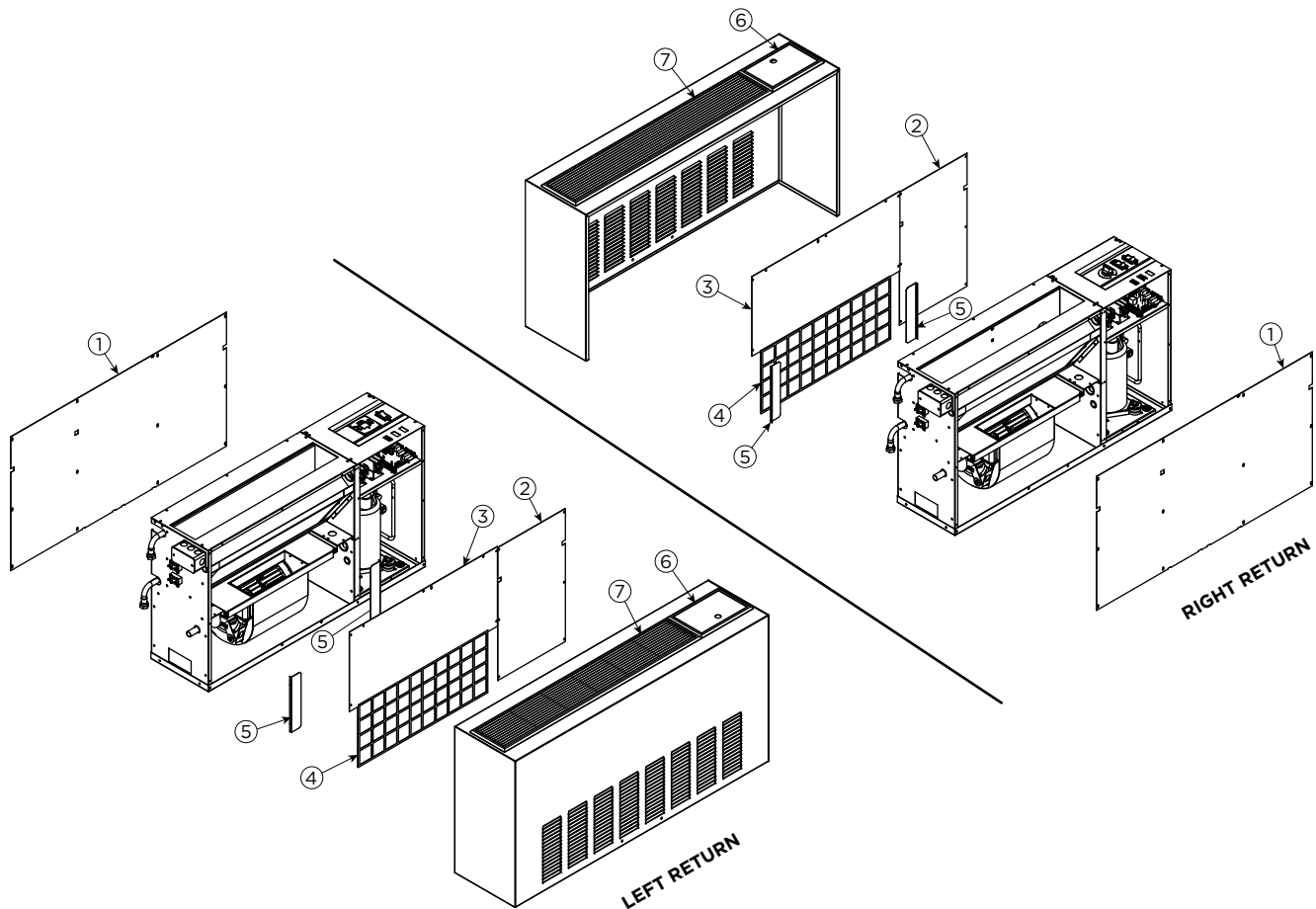

System Cleaning and Flushing

Cleaning and Flushing

Prior to start up of any heat pump, the water circulating system must be cleaned and flushed of all dirt and debris.

If the system is equipped with water shutoff valves, the supply and return runouts must be connected together at each unit location (This will prevent the introduction of dirt into the unit, see Figure 7). The system should be filled at the water make-up connection with all air vents open. After filling, vents should be closed.

The contractor should start the main circulator with the pressure reducing valve makeup open. Vents should be checked in sequence to bleed off any trapped air and to verify circulation through all components of the system.

As water circulates through the system, the contractor should check and repair any leaks found in the piping system. Drain(s) at the lowest point(s) in the system should be opened for initial flush and blowdown, making sure water fill valves are set at the same rate. Check the pressure gauge at the pump suction and manually adjust the make-up water valve to hold the same positive pressure both before and after opening the drain valves. Flushing should continue for at least two hours, or longer if required, until drain water is clean and clear.

The supplemental heater and/or circulator pump, if used, should be shut off. All drains and vents should be opened to completely drain the system. Short-circuited supply and return runouts should now be connected to the unit supply and return connections.

Refill the system with clean water. Test the system water for acidity and treat as required to leave the water slightly alkaline (pH 7.5 to 8.5). The specified percentage of antifreeze may also be added at this time. Use commercial grade antifreeze designed for HVAC systems only. Environol™ brand antifreeze is recommended..

Once the system has been filled with clean water and antifreeze (if used), precautions should be taken to protect the system from dirty water conditions. Dirty water will result in system-wide degradation of performance, and solids may clog valves, strainers, flow regulators, etc. Additionally, the heat exchanger may become clogged which reduces compressor service life and can cause premature unit failure.

In boiler/tower application, set the loop control panel set points to desired temperatures. Supply power to all motors and start the circulating pumps. After full flow has been established through all components including the heat rejector (regardless of season), air vented and loop temperatures stabilized, each of the units will be ready for check, test and start up and for air and water balancing.

Ground Source Loop System Checkout

Once piping is completed between the unit pumping system and ground loop, final purging and charging of the loop is needed. A high pressure pump is needed to achieve adequate flow velocity in the loop to purge air and dirt particles from the loop itself. Antifreeze solution is used in most areas to prevent freezing. Flush the system adequately to remove as much air as possible; then pressurize the loop to a static pressure of 40-50 psi (summer) or 50-75 psi (winter). This is normally adequate for good system operation. Loop static pressure may decrease soon after initial installation, due to pipe expansion and loop temperature change. Running the unit for at least 30 minutes after the system has been completely purged of air will allow for the "break-in" period. It may be necessary to adjust static loop pressure (by adding water) after the unit has run for the first time. Loop static pressure will also fluctuate with the seasons. Pressures will be higher in the winter months than during the cooling season. This fluctuation is normal and should be considered when charging the system initially.

Ensure the pump provides adequate flow through the unit by checking pressure drop across the heat exchanger. Usually 2.25-3.0 gpm of flow per ton of cooling capacity is recommended in earth loop applications.

Figure 7: Flushing with Water Shutoff Valve Equipped Systems

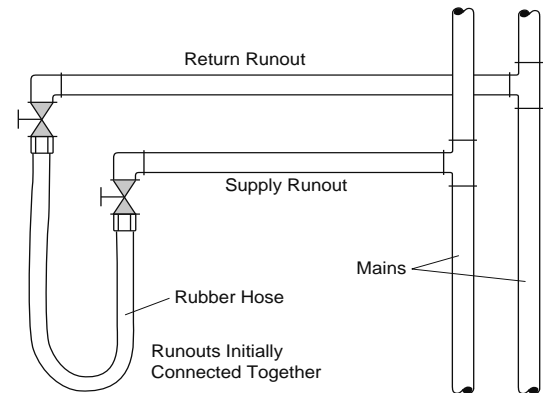

Open Loop Ground Water Systems

Always maintain water pressure in the heat exchanger by placing water control valves at the outlet of the unit to prevent mineral precipitation. Use a closed, bladder-type expansion tank to minimize mineral formation due to air exposure. Ensure proper water flow through the unit by checking pressure drop across the heat exchanger and comparing it to the figures in unit capacity data tables in the specification catalog. 1.5-2 gpm of flow per ton of cooling capacity is recommended in open loop applications.

Discharge water from the unit is not contaminated in any manner and can be disposed of in various ways, depending on local codes, i.e. recharge well, storm sewer, drain field, adjacent stream or pond, etc. Most local codes forbid the use of sanitary sewer for disposal. Consult your local building and zoning departments to assure compliance in your area.

Note: For open loop/groundwater systems or systems that do not contain an antifreeze solution, set SW1-Switch #2 to the “WELL” position (Refer to the Dip Switch Field Selection table). Slow opening/closing solenoid valves (type VM) are recommended to eliminate water hammer.

Water Quality

In ground water situations where scaling could be heavy or where biological growth such as iron bacteria will be present, a closed loop system is recommended. The heat exchanger coils in ground water systems may, over a period of time, lose heat exchange capabilities due to a buildup of mineral deposits inside. These can be cleaned, but only by a qualified service mechanic, as special solutions and pumping equipment are required. Desuperheater coils can likewise become scaled and possibly plugged. In areas with extremely hard water, the owner should be informed that the heat exchanger may require occasional flushing.

Units with cupronickel heat exchangers are recommended for open loop applications due to the increased resistance to build-up and corrosion, along with reduced wear caused by acid cleaning.

| Material | | Copper | 90/10 Cupronickel | 316 Stainless Steel |
|----------------------------------|-----------------------------------------------------------|-----------------------------------------------------------|-----------------------------------------------------------|-----------------------------------------------------------|
| pH | Acidity/Alkalinity | 7 - 9 | 7 - 9 | 7 - 9 |
| Scaling | Calcium and Magnesium Carbonate | (Total Hardness) less than 350 ppm | (Total Hardness) less than 350 ppm | (Total Hardness) less than 350 ppm |
| Corrosion | Hydrogen Sulfide | Less than 0.5 ppm (rotten egg smell appears at 0.5 ppm) | 10 - 50 ppm | Less than 1 ppm |
| | Sulfates | Less than 125 ppm | Less than 125 ppm | Less than 200 ppm |
| | Chlorine | Less than 0.5 ppm | Less than 0.5 ppm | Less than 0.5 ppm |
| | Chlorides | Less than 20 ppm | Less than 125 ppm | Less than 300 ppm |
| | Carbon Dioxide | Less than 50 ppm | 10 - 50 ppm | 10 - 50 ppm |
| | Ammonia | Less than 2 ppm | Less than 2 ppm | Less than 20 ppm |
| | Ammonia Chloride | Less than 0.5 ppm | Less than 0.5 ppm | Less than 0.5 ppm |
| | Ammonia Nitrate | Less than 0.5 ppm | Less than 0.5 ppm | Less than 0.5 ppm |
| | Ammonia Hydroxide | Less than 0.5 ppm | Less than 0.5 ppm | Less than 0.5 ppm |
| | Ammonia Sulfate | Less than 0.5 ppm | Less than 0.5 ppm | Less than 0.5 ppm |
| | Total Dissolved Solids (TDS) | Less than 1000 ppm | 1000 - 1500 ppm | 1000 - 1500 ppm |
| | LSI Index | +0.5 to -0.5 | +0.5 to -0.5 | +0.5 to -0.5 |
| Iron Fouling (Biological Growth) | Iron, FE ²⁺ (Ferrous) Bacterial Iron Potential | < 0.2 ppm | < 0.2 ppm | < 0.2 ppm |
| | Iron Oxide | Less than 1 ppm, above this level deposition will occur | Less than 1 ppm, above this level deposition will occur | Less than 1 ppm, above this level deposition will occur |
| Erosion | Suspended Solids | Less than 10 ppm and filtered for max. of 600 micron size | Less than 10 ppm and filtered for max. of 600 micron size | Less than 10 ppm and filtered for max. of 600 micron size |
| | Threshold Velocity (Fresh Water) | < 6 ft/sec | < 6 ft/sec | < 6 ft/sec |

NOTES: Grains = ppm divided by 17
mg/L is equivalent to ppm

2/22/12

Electrical Connections

General

Be sure the available power is the same voltage and phase as that shown on the unit serial plate. Line and low voltage wiring must be done in accordance with local codes or the National Electric Code, whichever is applicable.

208 Volt Operation

All 208/230 units are factory wired for 230 volt operation. For 208 volt operation, the red and blue transformer wires must be switched.

Microprocessor Remote Thermostat Wiring

Figure 5

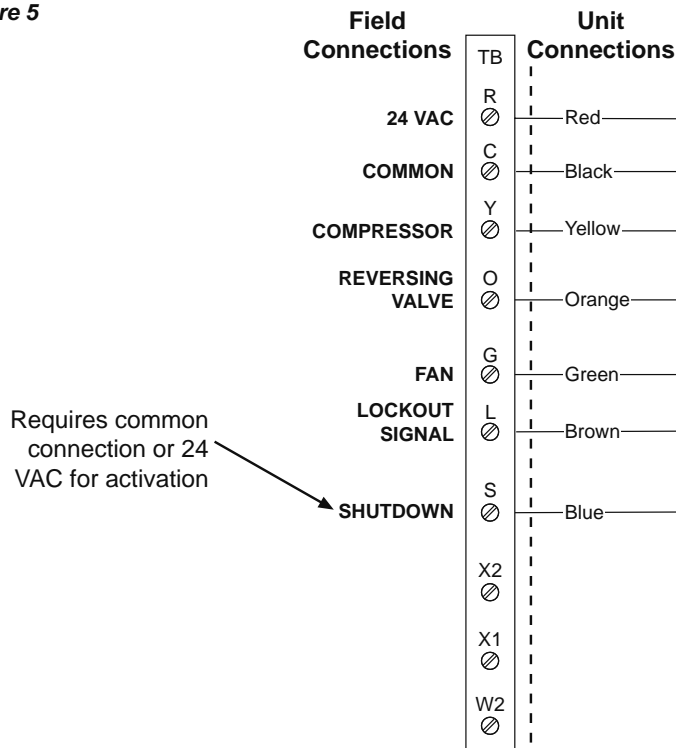

Electrical Data

| Model | Rated Voltage | Voltage Min/Max | Compressor | | | Blower Motor FLA | Total Unit FLA | Min Circ Amp | Max Fuse/HACR |
|-------|---------------|-----------------|------------|-----|------|------------------|----------------|--------------|---------------|
| | | | MCC | RLA | LRA | | | | |
| 09 | 115/60/1 | 104/127 | 12.5 | 8.0 | 50.0 | 1.5 | 9.5 | 11.5 | 15 |
| | 208-230/60/1 | 187/253 | 6.4 | 4.1 | 21.0 | 0.6 | 4.7 | 5.7 | 10/15 |
| | 265/60/1 | 238/292 | 6.7 | 4.3 | 22.0 | 0.6 | 4.9 | 6.0 | 10/15 |
| 12 | 115/60/1 | 104/127 | 14.8 | 9.5 | 50.0 | 1.5 | 11.0 | 13.4 | 20 |
| | 208-230/60/1 | 187/253 | 7.7 | 4.9 | 25.0 | 0.6 | 5.5 | 6.7 | 10/15 |
| | 265/60/1 | 238/292 | 7.0 | 4.5 | 22.0 | 0.6 | 5.1 | 6.2 | 10/15 |
| 15 | 208-230/60/1 | 187/253 | 9.2 | 5.9 | 29.0 | 2.6 | 8.5 | 10.0 | 15 |
| | 265/60/1 | 238/292 | 7.8 | 5.0 | 28.0 | 2.5 | 7.5 | 8.7 | 10/15 |
| 18 | 208-230/60/1 | 187/253 | 10.4 | 6.7 | 33.5 | 2.6 | 9.3 | 11.0 | 15 |
| | 265/60/1 | 238/292 | 8.7 | 5.6 | 28.0 | 2.5 | 8.1 | 9.5 | 15 |

HACR circuit breaker in USA only

6/10/13

Blower Performance Data

| Model | CFM | |
|-------|-----------|------------|
| | Low Speed | High Speed |
| 09 | 260 | 300 |
| 12 | 300 | 340 |
| 15 | 375 | 450 |
| 18 | 450 | 600 |

Air flow values are with dry coil and standard filter.

For wet coil performance, first calculate the face velocity of the air coil (face velocity (fpm) = airflow (cfm) / face area (sq ft))

Wiring Schematics

ABC - with PSC Motor and Electronic Stat - 208-230-265/60/1

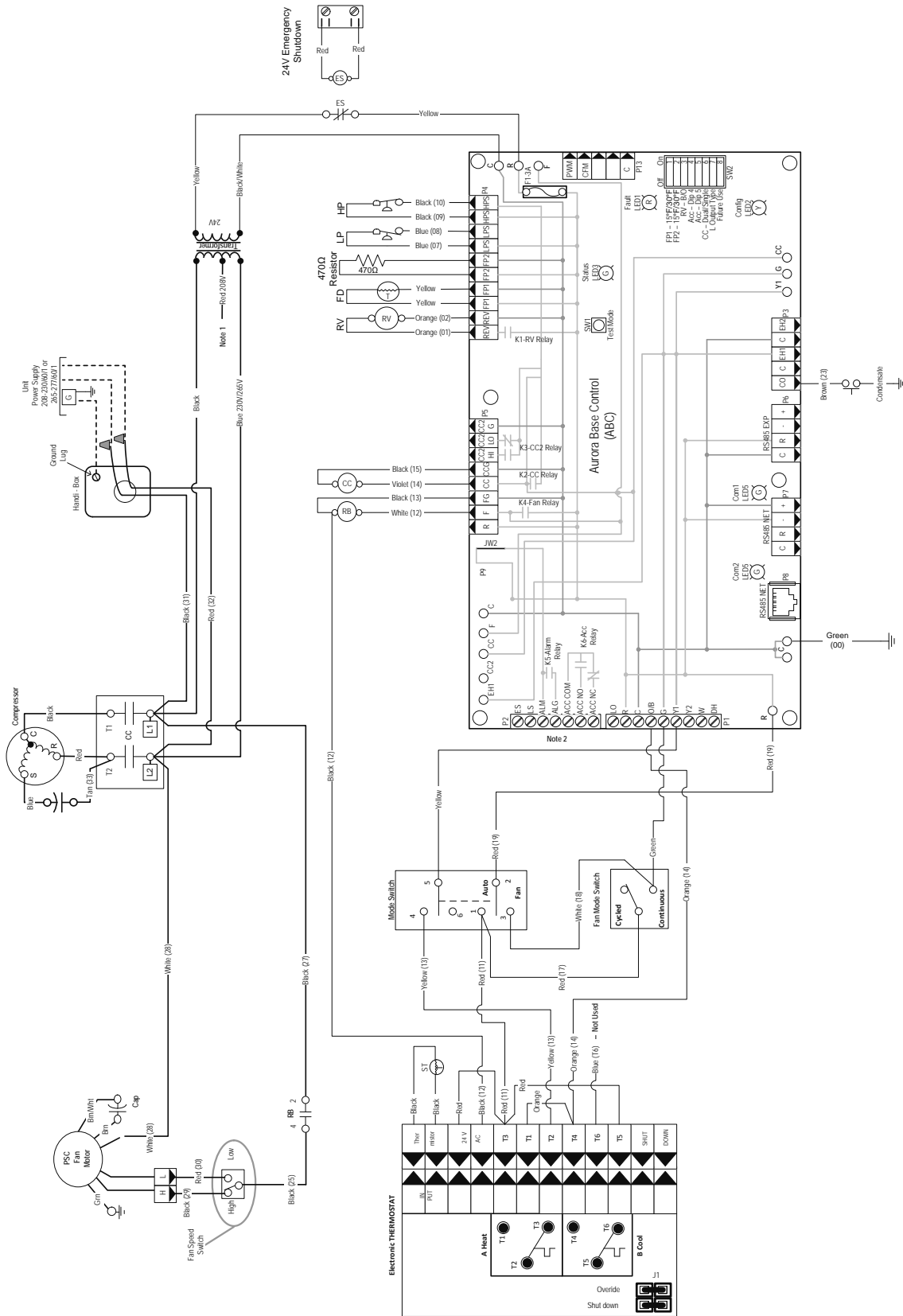

Wiring Schematics cont.

ABC - with PSC Motor and Electronic Stat - 208-230-265/60/1

| Accessory Relay | | |
|-----------------------|-------|-------|
| Operation | SW2-4 | SW2-5 |
| Cycle with Blowers | On | On |
| Cycle with compressor | Off | Off |
| Water Valve Slow Open | On | Off |
| Outdoor Air Damper | Off | On |

| Aurora Timing Events | | |
|----------------------------------------------------|--------------------|--------------------|
| Event | Normal Mode | Test Mode |
| Random Start Delay | 5 to 80 seconds | 1 second |
| Compressor On Delay | 5 seconds | < 1 second |
| Compressor Minimum On Time | 2 minutes | 5 seconds |
| Compressor Short Cycle Delay | 4 minutes | 15 seconds |
| Blower Off Delay | 30 seconds | 2 seconds |
| Fault Recognition Delay - High Pressure | Less than 1 second | Less than 1 second |
| Start-Up Bypass - Low Pressure | 2 minutes | 30 seconds |
| Fault Recognition Delay - Low Pressure | 30 seconds | 30 seconds |
| Start-Up Bypass - Low Water/Air Coil Limit | 2 minutes | 30 seconds |
| Fault Recognition Delay - Low Water/Air Coil Limit | 30 seconds | 30 seconds |
| Fault Recognition Delay - Condensate Overflow | 30 seconds | 30 seconds |
| Thermostat Call Recognition Time | 2 seconds | 2 seconds |
| Auxiliary Heat Staging Delay | 5 minutes | 20 seconds |
| Emergency Heat Staging Delay | 2 minutes | 7.5 seconds |
| Water Valve Slow Open Delay | 90 seconds | 90 seconds |
| Reheat Delay | 30 seconds | 30 seconds |

| Aurora LED Flash Codes | | | |
|----------------------------------|-------------------------------------------------------------------------------------|-----------------------------------------|------------------------------------|
| Slow Flash | 1 second on and 1 second off | | |
| Fast Flash | 100 milliseconds on and 100 milliseconds off | | |
| Flash Code | 100 milliseconds on and 400 milliseconds off with a 2 second pause before repeating | | |
| Random Start Delay | | | |
| Status LED (LED1, Green) | Fast Flash | | |
| Configuration LED (LED2, Yellow) | Fast Flash | | |
| Fault LED (LED3, Red) | Fast Flash | | |
| Status LED (LED1, Green) | | Configuration LED (LED2, Yellow) | |
| Normal Mode | ON | No Software Override | Flash ECM Setting |
| Control is Non-Functional | OFF | DIP Switch Override | Slow Flash |
| Test Mode | Slow Flash | ECM Configure Mode | Fast Flash |
| Lockout Active | Fast Flash | Reset Configure Mode | Off |
| Dehumidification Mode | Flash Code 2 | | Low Air Coil Limit Lockout - FP1 |
| Reserved | Flash Code 3 | | Low Water Coil Limit Lockout - FP1 |
| Reserved | Flash Code 4 | | Reserved |
| Load Shed | Flash Code 5 | | Condensate Overflow Lockout |
| ESD | Flash Code 6 | | Over/Under Voltage Shutdown |
| Reserved | Flash Code 7 | | Reserved |
| | | | Reserved |
| | | | Flash Code 10 |
| | | | Flash Code 11 |

Notes:

- 1 - Swap blue and red leads for 208V operation.
- 2 - Use ALG Output for 24V lockout.

Legend

| | | | |
|--|-----------------------------|--|-------------------------------|
| | Factory Low Voltage Wiring | | Thermistor |
| | Factory Line Voltage Wiring | | Relay Coil |
| | Field Low Voltage Wiring | | Switch - Condensate Overflow |
| | Field Line Voltage Wiring | | Switch - High pressure |
| | Optional Block | | Switch - Low pressure |
| | DC Voltage PCB Traces | | Polarized connector |
| | Field Zone Sensor Wiring | | Light Emitting Diode - Green |
| | Internal Junction | | Light Emitting Diode - Yellow |
| | Quick Connect Terminal | | Light Emitting Diode - Red |
| | Field Wiring Lug | | Wire nut |
| | Ground | | |
| | Relay Contacts - N.O., N.C. | | |
| | Capacitor | | |
| | Fuse | | |
| | Temperature Switch | | |

CC - Compressor Contactor
 CO - Condensate Overflow Sensor
 ES - Emergency Shutdown
 PB - Power Block
 HP - High Pressure Switch
 LP - Low Pressure Switch
 FD - Freeze Detection Sensor
 F1 - Fuse

SW1 - Push button
 SW2 - DIP package 8 position
 PB - Power Block
 RB - Blower Relay
 RV - Reversing Valve Coil

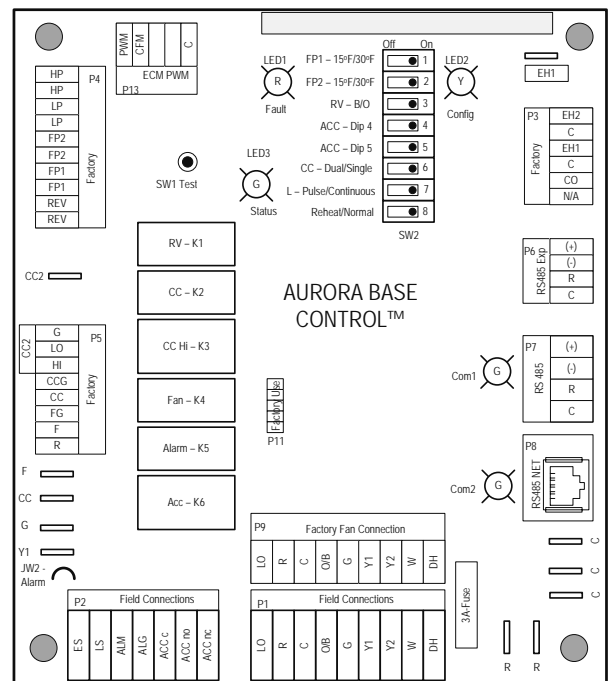

Wiring Schematics cont.

ABC - PSC Motor with Remote Stat - 208-230-265/60/1

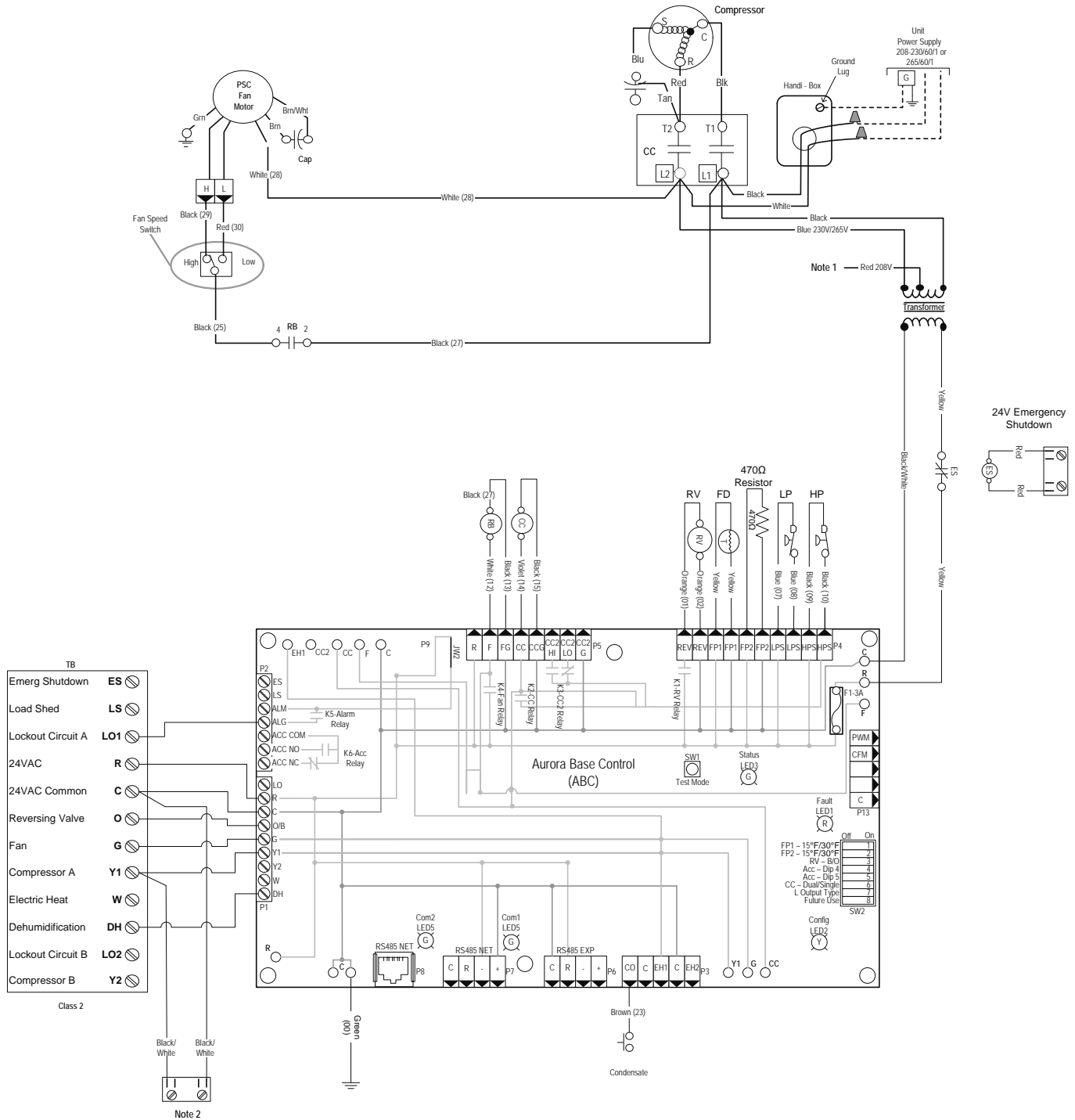

Wiring Schematics cont.

ABC - PSC Motor with Remote Stat - 208-230-265/60/1

Notes:

- 1 - Swap blue and red leads for 208V operation.
- 2 - When field installed 24VAC motorized valve is used, connect to C and Y.

| Accessory Relay | | |
|-----------------------|-------|-------|
| Operation | SW2-4 | SW2-5 |
| Cycle with Blower | On | On |
| Cycle with Compressor | Off | Off |
| Water Valve Slow Open | On | Off |
| Outdoor Air Damper | Off | On |

| Aurora Timing Events | | |
|----------------------------------------------------|--------------------|--------------------|
| Event | Normal Mode | Test Mode |
| Random Start Delay | 5 to 80 seconds | 1 second |
| Compressor On Delay | 5 seconds | - 1 second |
| Compressor Minimum On Time | 2 minutes | 5 seconds |
| Compressor Short Cycle Delay | 4 minutes | 15 seconds |
| Blower Off Delay | 30 seconds | 2 seconds |
| Fault Recognition Delay - High Pressure | Less than 1 second | Less than 1 second |
| Start-Up Bypass - Low Pressure | 2 minutes | 30 seconds |
| Fault Recognition Delay - Low Pressure | 30 seconds | 30 seconds |
| Start-Up Bypass - Low Water/Air Coil Limit | 2 minutes | 30 seconds |
| Fault Recognition Delay - Low Water/Air Coil Limit | 30 seconds | 30 seconds |
| Fault Recognition Delay - Condensate Overflow | 30 seconds | 30 seconds |
| Thermostat Call Recognition Time | 2 seconds | 2 seconds |
| Auxiliary Heat Staging Delay | 5 minutes | 20 seconds |
| Emergency Heat Staging Delay | 2 minutes | 7.5 seconds |
| Water Valve Slow Open Delay | 90 seconds | 90 seconds |
| Reheat Delay | 30 seconds | 30 seconds |

| Aurora LED Flash Codes | | | |
|----------------------------------|-------------------------------------------------------------------------------------|------------------------------------|-------------------|
| Slow Flash | 1 second on and 1 second off | | |
| Fast Flash | 100 milliseconds on and 100 milliseconds off | | |
| Flash Code | 100 milliseconds on and 400 milliseconds off with a 2 second pause before repeating | | |
| Random Start Delay | | | |
| Status LED (LED1, Green) | Fast Flash | | |
| Configuration LED (LED2, Yellow) | Fast Flash | | |
| Fault LED (LED3, Red) | Fast Flash | | |
| Status LED (LED1, Green) | | Configuration LED (LED2, Yellow) | |
| Normal Mode | ON | No Software Override | Flash ECM Setting |
| Control is Non-Functional | OFF | DIP Switch Override | Slow Flash |
| Test Mode | Slow Flash | ECM Configure Mode | Fast Flash |
| Lockout Active | Fast Flash | Reset Configure Mode | Off |
| Dehumidification Mode | Flash Code 2 | Fault LED (LED3, Red) | |
| Reserved | Flash Code 3 | Low Air Coil Limit Lockout - FP2 | Flash Code 4 |
| Reserved | Flash Code 4 | Low Water Coil Limit Lockout - FP1 | Flash Code 5 |
| Lead Shed | Flash Code 5 | Reserved | Flash Code 6 |
| ESD | Flash Code 6 | Condensate Overflow Lockout | Flash Code 7 |
| Reserved | Flash Code 7 | Over/Under Voltage Shutdown | Flash Code 8 |
| | | Reserved | Flash Code 9 |
| | | Reserved | Flash Code 10 |
| | | Air/Water Coil Limit Sensor Error | Flash Code 11 |

Legend

| | | | |
|--|-----------------------------|--|-------------------------------|
| | Factory Low Voltage Wiring | | Thermistor |
| | Factory Line Voltage Wiring | | Relay Coil |
| | Field Low Voltage Wiring | | Switch - Condensate Overflow |
| | Field Line Voltage Wiring | | Switch - High pressure |
| | Optional Block | | Switch - Low pressure |
| | DC Voltage PCB Traces | | Polarized connector |
| | Field Zone Sensor Wiring | | Light Emitting Diode - Green |
| | Internal Junction | | Light Emitting Diode - Yellow |
| | Quick Connect Terminal | | Light Emitting Diode - Red |
| | Field Wiring Lug | | Wire nut |
| | Ground | | |
| | Capacitor | | |
| | Fuse | | |
| | Temperature Switch | | |

CC - Compressor Contactor
 CO - Condensate Overflow Sensor
 ES - Emergency Shutdown
 HP - High Pressure Switch
 LP - Low Pressure Switch
 FD - Freeze Detection Sensor
 F1 - Fuse

SW1 - Push button
 SW2 - DIP package 8 position
 PB - Power Block
 RB - Blower Relay
 RV - Reversing Valve Coil

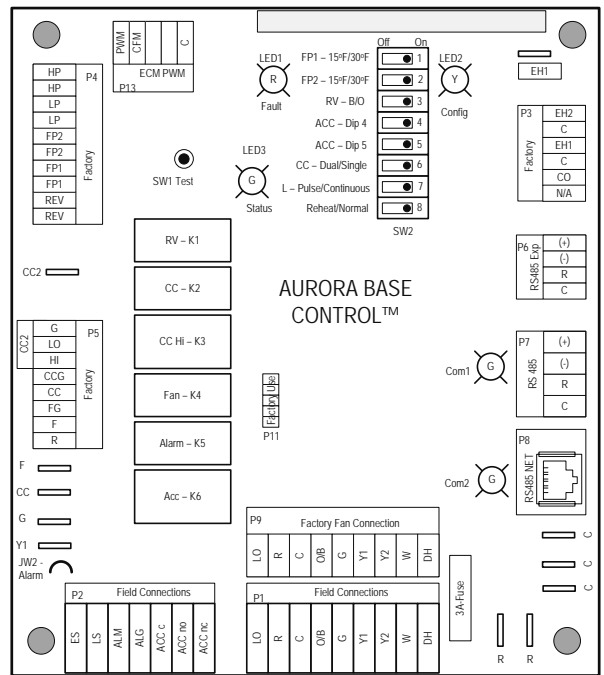

Wiring Schematics cont.

ABC - with ECM Motor and Electronic Stat - 208-230-265/60/1

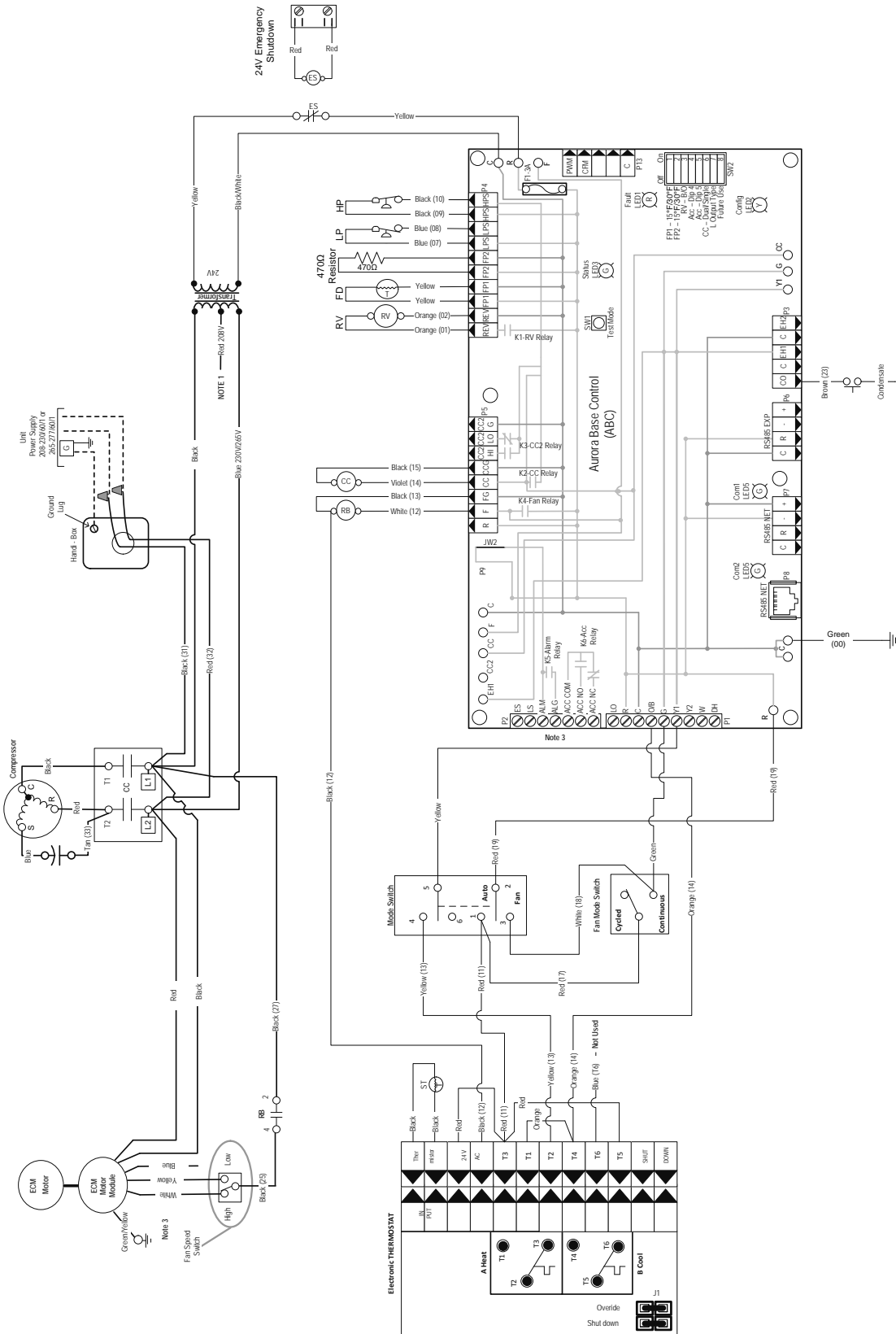

Wiring Schematics cont.

ABC - with ECM Motor and Electronic Stat - 208-230-265/60/1

| Accessory Relay | | |
|-----------------------|-------|-------|
| Operation | SW2-4 | SW2-5 |
| Cycle with Blower | On | On |
| Cycle with Compressor | Off | Off |
| Water Valve Slow Open | On | Off |
| Outdoor Air Damper | Off | On |

| Aurora Timing Events | | |
|----------------------------------------------------|--------------------|--------------------|
| Event | Normal Mode | Test Mode |
| Random Start Delay | 5 to 80 seconds | 1 second |
| Compressor On Delay | 5 seconds | < 1 second |
| Compressor Minimum On Time | 2 minutes | 5 seconds |
| Compressor Short Cycle Delay | 4 minutes | 15 seconds |
| Blower Off Delay | 30 seconds | 2 seconds |
| Fault Recognition Delay - High Pressure | Less than 1 second | Less than 1 second |
| Start-Up Bypass - Low Pressure | 2 minutes | 30 seconds |
| Fault Recognition Delay - Low Pressure | 30 seconds | 30 seconds |
| Start-Up Bypass - Low Water/Air Coil Limit | 2 minutes | 30 seconds |
| Fault Recognition Delay - Low Water/Air Coil Limit | 30 seconds | 30 seconds |
| Fault Recognition Delay - Condensate Overflow | 30 seconds | 30 seconds |
| Thermostat Call Recognition Time | 2 seconds | 2 seconds |
| Auxiliary Heat Staging Delay | 5 minutes | 20 seconds |
| Emergency Heat Staging Delay | 2 minutes | 7.5 seconds |
| Water Valve Slow Open Delay | 90 seconds | 90 seconds |
| Reheat Delay | 30 seconds | 30 seconds |

| Aurora LED Flash Codes | | | |
|----------------------------------|-------------------------------------------------------------------------------------|------------------------------------|-------------------|
| Slow Flash | 1 second on and 1 second off | | |
| Fast Flash | 100 milliseconds on and 100 milliseconds off | | |
| Flash Code | 100 milliseconds on and 400 milliseconds off with a 2 second pause before repeating | | |
| Random Start Delay | | | |
| Status LED (LED1, Green) | Fast Flash | | |
| Configuration LED (LED2, Yellow) | Fast Flash | | |
| Fault LED (LED3, Red) | Fast Flash | | |
| Status LED (LED1, Green) | Configuration LED (LED2, Yellow) | Fault LED (LED3, Red) | |
| Normal Mode | ON | No Software Override | Flash ECM Setting |
| Control Is Non-Functional | OFF | DIP Switch Override | Slow Flash |
| Test Mode | Slow Flash | ECM Configure Mode | Fast Flash |
| Lockout Active | Fast Flash | Reset Configure Mode | Off |
| Dehumidification Mode | Flash Code 2 | | |
| Reserved | Flash Code 3 | | |
| Reserved | Flash Code 4 | | |
| Load Shed | Flash Code 5 | | |
| ESD | Flash Code 6 | | |
| Reserved | Flash Code 7 | | |
| | | Normal Mode | OFF |
| | | High Pressure Lockout | Flash Code 1 |
| | | Low Pressure Lockout | Flash Code 3 |
| | | Low Air Coil Limit Lockout - FP2 | Flash Code 4 |
| | | Low Water Coil Limit Lockout - FP1 | Flash Code 5 |
| | | Reserved | Flash Code 6 |
| | | Condensate Overflow Lockout | Flash Code 7 |
| | | Over/Under Voltage Shutdown | Flash Code 8 |
| | | Reserved | Flash Code 9 |
| | | Reserved | Flash Code 10 |
| | | Air/Water Coil Limit Sensor Error | Flash Code 11 |

| Blower Settings | | |
|-----------------|--------|--------|
| | High | Low |
| LC*15 | Yellow | White |
| LC*18 | Blue | Yellow |

Notes:

- 1 - Swap blue and red leads for 208V operation.
- 2 - Use ALG Output for 24V lockout.
- 3 - Factory wired. Refer to blower table settings.

Legend

| | | | |
|--|-----------------------------|--|-------------------------------|
| | Factory Low Voltage Wiring | | Thermistor |
| | Factory Line Voltage Wiring | | Relay Coil |
| | Field Low Voltage Wiring | | Switch - Condensate Overflow |
| | Field Line Voltage Wiring | | Switch - High pressure |
| | Optional Block | | Switch - Low pressure |
| | DC Voltage PCB Traces | | Polarized connector |
| | Field Zone Sensor Wiring | | Light Emitting Diode - Green |
| | Internal Junction | | Light Emitting Diode - Yellow |
| | Quick Connect Terminal | | Light Emitting Diode - Red |
| | Field Wiring Lug | | Wire nut |
| | Ground | | |
| | Relay Contacts - N.O., N.C. | | |
| | Capacitor | | |
| | Fuse | | |
| | Temperature Switch | | |

CC - Compressor Contactor
 CO - Condensate Overflow Sensor
 ES - Emergency Shutdown
 HP - High Pressure Switch
 LP - Low Pressure Switch
 FD - Freeze Detection Sensor
 F1 - Fuse
 SW1 - Push button
 SW2 - DIP package 8 position
 PB - Power Block
 RB - Blower Relay
 RV - Reversing Valve Coil

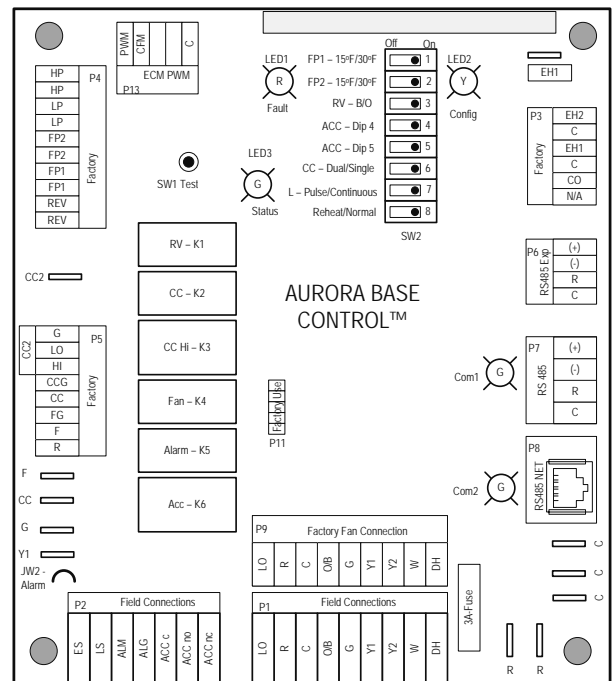

Controls

| Control | General Description | Application | Display/Interface | Protocol | Thermostat Options |
|--------------------------------------------------------------------------------------------------|----------------------------------------------------------------------------------------------------------------------------------------------------------------------------------------------------------------------------------------------------------------------------------------------------------------|------------------------------------------------------------------------------------------------------------------------------------------------------------------------|-------------------------------------------------------------------------------------------------------|----------|--------------------------------------|
| CCM Control  | The CCM (Compressor control module) is a more reliable replacement for electro-mechanical control applications. It features a small microprocessor board that handles the lockout function of the unit. A second microprocessor handles the unit mounted thermostat for maintaining accurate room temperature. | Residential and commercial applications requiring minimal but reliable controls. Includes Random Start, High and low pressure switches and auto changeover capability. | Dial thermostat with Hi and Low blower speeds, and auto changeover or cont blower selection switches. | None | Unit Mounted Digital Dial Thermostat |
| | | | | | Remote Mounted Standard Thermostat |

Standard CCM Control Features

Compressor control module (CCM) controls are standard on the Aston Series Low Sill Console heat pump. This control features unit mounted thermostat and switches,

Features of the standard control are:

- Easy to understand color coded thermostat adjustment markings.
- Large, rocker type mode and blower switches.
- Internally mounted blower switch to choose cycled or constant blower operation.
- High pressure and low pressure safety controls to protect the unit components.
- Lockout circuit to shut down unit operation upon receipt of a fault indicator from the safety controls.
- A 24 volt control circuit allows for safe and easy diagnosis.

The user selects either “Heat/Cool” or “Fan Only” on the mode switch, then either “High” or “Low” at the blower speed switch. The temperature can be controlled by rotating the thermostat control knob.

Unit Mounted Control

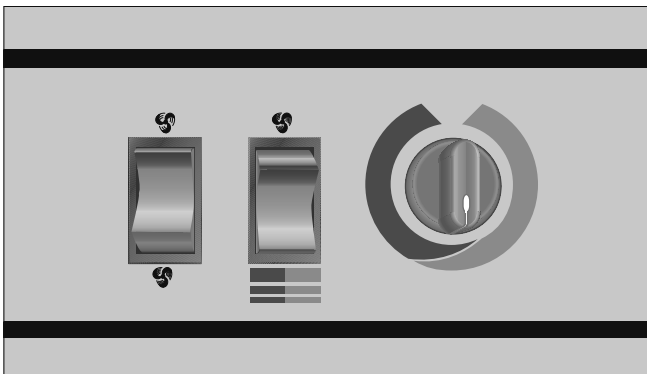

The “Fan Only” setting provides constant blower operation.

In the “Heat” mode, a call for heat by the thermostat closes the compressor contactor contacts, energizing the compressor, which will run until the thermostat is satisfied.

In the “Cool” mode, a call for cooling by the thermostat energizes the reversing valve and closes the compressor contactor contacts, energizing the compressor, which will run until the thermostat is satisfied.

If either the low or high pressure safety switches are opened, the compressor and reversing valve are disabled by the lockout relay. Unit operation will resume only after the voltage to the unit is interrupted or the mode switch is placed in the “Off” position.

Controls cont.

Aurora 'Base' Control

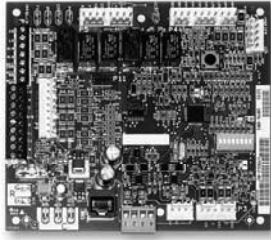

NOTE: Refer to the Aurora Base Control Application and Troubleshooting Guide and the Instruction Guide: Aurora Interface and Diagnostics (AID) Tool for additional information.

Control Features

Software ABC Standard Version 3.0

Single or Dual Capacity Compressors

Either single or dual capacity compressors can be operated.

Variable Speed ECM

Blower Motor Option (If Applicable)

A Variable Speed ECM blower motor can be driven directly using the onboard PWM output. Four blower speeds are available based upon the G, Y1, Y2, and W input signals to the board. The blower speeds can be changed either by the ECM manual configurations mode method or by using the Aurora AID Tool directly. All four blower speeds can be set to the same speed if desired.

5-Speed ECM Blower Motor Option (If Applicable)

A 5-Speed ECM blower motor will be driven directly using the thermostat connections. Any of the G, Y1, or Y2/W signals can drive any of the 5 available pre-programmed blower speeds on the motor. All 5 Series "G" vintage units will be wired this way at the factory.

Other Control Features

- Random start at power up
- Anti-short cycle protection
- High and low pressure cutouts
- Loss of charge
- Water coil freeze detection
- Air coil freeze detection
- Over/under voltage protection
- Condensate overflow sensor
- Load shed
- Dehumidification (where applicable)
- Emergency shutdown
- Hot gas reheat operation (where applicable)
- Diagnostic LED
- Test mode push button switch
- Two auxiliary electric heat outputs
- Alarm output
- Accessory output with N.O. and N.C.
- Modbus communication (master)
- Modbus communication (slave)

Field Selectable Options via Hardware

DIP Switch (SW1) – Test/Configuration Button (See SW1 Operation Table)

Test Mode

The control is placed in the test mode by holding the push button switch SW1 for 2 - 5 seconds. In test mode most of the control timings will be shortened by a factor of sixteen (16). LED3 (green) will flash at 1 second on and 1 second off. Additionally, when entering test mode LED1 (red) will flash the last lockout one time. Test mode will automatically time out after 30 minutes. Test mode can be exited by pressing and holding the SW1 button for 2 to 5 seconds or by cycling the power. **NOTE:** Test mode will automatically be exited after 30 minutes.

Variable Speed ECM Configuration Mode (If Applicable)

The control is placed in the ECM configuration mode by holding the pushbutton switch SW1 for 5 to 10 seconds, the high, low, and "G" ECM speeds can be selected by following the LED display lights. LED2 (yellow) will fast flash when entering the ECM configuration. When setting "G" speed LED3 (green) will be continuously lit, for low speed LED1 (red) will be continuously lit, and for high speed both LED3 (green) and LED1 (red) will be continuously lit. During the ECM configuration mode LED2 (yellow) will flash each of the 12 possible blower speeds 3 times. When the desired speed is flashed press SW1, LED2 will fast flash until SW1 is released. "G" speed has now been selected. Next select low speed, and high speed blower selections following the same process above. After third selection has been made, the control will exit the ECM configuration mode. Aux fan speed will remain at default or current setting and requires the AID Tool for adjustment.

Reset Configuration Mode

The control is placed in reset configuration mode by holding the push button switch SW1 for 50 to 60 seconds. This will reset all configuration settings and the EEPROM back to the factory default settings. LED3 (green) will turn off when entering reset configuration mode. Once LED3 (green) turns off, release SW1 and the control will reset.

DIP Switch (SW2)

- SW2-1** FP1 Selection – Low water coil temperature limit setting for freeze detection. On = 30°F; Off = 15°F.
- SW2-2** FP2 Selection – On = 30°F; Off = N/A
- SW2-3** RV - O/B - thermostat type. Heat pump thermostats with "O" output in cooling or "B" output in Heating can be selected. On = O; Off = B.
- SW2-4 and 2-5** Access Relay Operation (P2)

| Access Relay Operation | SW2-4 | SW2-5 |
|---------------------------------|-------|-------|
| Cycle with Blower | ON | ON |
| Cycle with Compressor | OFF | OFF |
| Water Valve Slow Opening | ON | OFF |
| Cycle with Comm. T-stat Hum Cmd | OFF | ON |

Controls cont.

Cycle with Blower - The accessory relay will cycle with the blower output.

Cycle with Compressor - The accessory relay will cycle with the compressor output.

Water Valve Slow Opening - The accessory relay will cycle and delay both the blower and compressor output for 90 seconds.

SW2-6 CC Operation – selection of single or dual capacity compressor. On = Single Stage; Off = Dual Capacity

SW2-7 Lockout and Alarm Outputs (P2) – selection of a continuous or pulsed output for both the LO and ALM Outputs. On = Continuous; Off = Pulsed

SW2-8 Future Use

Alarm Jumper Clip Selection

From the factory, ALM is connected to 24 VAC via JW2. By cutting JW2, ALM becomes a dry contact connected to ALG.

Variable Speed ECM Blower Speeds

The blower speeds can be changed either by using the ECM manual configurations mode method or by using the Aurora AID Tool directly (see Instruction Guide: Aurora Interface and Diagnostics (AID) Tool topic).

Field Selectable Options via Software

(Selectable via the Aurora AID Tool)

ECM Blower Speeds

An ECM blower motor can be driven directly using the onboard PWM output. Four blower speeds are available, based upon the “G”, Y1 (low), Y2 (high), and Aux input signals to the board. The blower speeds can be changed either by the ECM manual configurations mode method (see ECM Configuration Mode topic) or by using the Aurora AID Tool directly. All four blower speeds can be set to the same speed if desired. Aux blower speed will remain at default or current setting and requires the AID Tool for adjustment.

Safety Features

The following safety features are provided to protect the compressor, heat exchangers, wiring and other components from damage caused by operation outside of design conditions.

Fuse – a 3 amp automotive type plug-in fuse provides protection against short circuit or overload conditions.

Anti-Short Cycle Protection – 4 minute anti-short cycle protection for the compressor.

Random Start – 5 to 80 second random start upon power up.

Fault Retry – in the fault condition, the control will stage off the outputs and then “try again” to satisfy the thermostat Y input call. Once the thermostat input calls are satisfied, the control will continue on as if no fault occurred. If 3 consecutive faults occur without satisfying the thermostat Y input call, then the control will go to Lockout mode.

Lockout – when locked out, the blower will operate continuously in “G” speed, and PSC blower motor output will remain on. The Alarm output (ALM) and Lockout output (L) will be turned on. The fault type identification display LED1 (Red) shall flash the fault code. To reset lockout conditions with SW2-8 On, thermostat inputs “Y1”, “Y2”, and “W” must be removed for at least 3 seconds. To reset lockout conditions with SW2-8 Off, thermostat inputs “Y1”, “Y2”, “W”, and “DH” must be removed for at least 3 seconds. Lockout may also be reset by turning power off for at least 30 seconds or by enabling the emergency shutdown input for at least 3 seconds.

Lockout With Emergency Heat – if the control is locked out in the heating mode, and a Y2 or W input is received, the control will operate in the emergency heat mode while the compressor is locked out. The first emergency heat output will be energized 10 seconds after the W input is received, and the blower will shift to high speed. If the control remains locked out, and the W input is present, additional stage of emergency heat will stage on after 2 minutes. When the W input is removed, all of the emergency heat outputs will turn off, and the ECM blower will shift to “G” speed and PSC blower motor output will remain on.

High Pressure – fault is recognized when the Normally Closed High Pressure Switch, P4-9/10 opens, no matter how momentarily. The High Pressure Switch is electrically in series with the Compressor Contactor and serves as a hard-wired limit switch if an overpressure condition should occur.

Low Pressure – fault is recognized when the Normally Closed Low Pressure Switch, P4-7/8 is continuously open for 30 seconds. Closure of the LPS any time during the 30 second recognition time restarts the 30 second continuous open requirement. A continuously open LPS shall not be recognized during the 2 minute startup bypass time.

Loss of Charge – fault is recognized when the Normally Closed Low Pressure Switch, P4-7/8 is open prior to the compressor starting.

Condensate Overflow – fault is recognized when the impedance between this line and 24 VAC common or chassis ground drops below 100K ohms for 30 seconds continuously.

Freeze Detection (Coax) – set points shall be either 30°F or 15°F. When the thermistor temperature drops below the selected set point, the control shall begin counting down the 30 seconds delay. If the thermistor value rises above the selected set point, then the count should reset. The resistance value must remain below the selected set point for the entire length of the appropriate delay to be recognized as a fault. This fault will be ignored for the initial 2 minutes of the compressor run time.

Freeze Detection (Air Coil) – uses the FP2 input to protect against ice formation on the air coil. The FP2 input will operate exactly like FP1 except that the set point is 30 degrees and is not field adjustable.

Controls cont.

Over/Under Voltage Shutdown - An over/under voltage condition exists when the control voltage is outside the range of 18 VAC to 30 VAC. If the over/under voltage shutdown lasts for 15 minutes, the lockout and alarm relay will be energized. Over/under voltage shutdown is self-resetting in that if the voltage comes back within range of 18 VAC to 30 VAC for at least 0.5 seconds, then normal operation is restored.

Operation Description

Power Up - The unit will not operate until all the inputs and safety controls are checked for normal conditions. The unit has a 5 to 80 second random start delay at power up. Then the compressor has a 4 minute anti-short cycle delay after the random start delay.

Standby In standby mode, Y1, Y2, W, DH, and G are not active. Input O may be active. The blower and compressor will be off.

Heating Operation

Single Compressor Heating, 2nd Stage (Y1, Y2)

The compressor will be staged to full capacity 20 seconds after Y2 input is received. The ECM blower will shift to high speed seconds after the Y2 input is received.

Dual Compressor Heating, 2nd Stage (Y1, Y2)

In dual compressor operation, two ABC boards used in 24 VAC operation, there will be a Y2 call to the Y1 input on the second ABC. The compressor will stage to full capacity 30 seconds after Y1 input is received to the second board.

Single Compressor Heating, 3rd Stage (Y1, Y2, W)

The hot water pump is de-energized and the first stage of electric heat is energized 10 seconds after the W command is received. If the demand continues the second stage of electric heat will be energized after 5 minutes.

Dual Compressor Heating, 3rd Stage (Y1, Y2, W) -

The first stage of electric heat is energized 10 seconds after the W command is received. If the demand continues the second stage of electric heat will be energized after 5 minutes

Emergency Heat (W) - The blower will be started on "G" speed, 10 seconds later the first stage of electric heat will be turned on. 5 seconds after the first stage of electric heat is energized the blower will shift to Aux speed. If the emergency heat demand is not satisfied after 2 minutes the second electric heat stage will be energized.

Blower (G) - The blower will start immediately upon receiving a thermostat G command. If there are no other commands from the thermostat the ECM will run on "G" speed until the G command is removed. Regardless of blower input (G) from the thermostat, the blower will remain on for 30 seconds at the end of each heating cycle.

Cooling Operation

In all cooling operations, the reversing valve directly tracks the O input. Thus, anytime the O input is present, the reversing valve will be energized.

Single Compressor Cooling, 2nd Stage (Y1, Y2, O)

The compressor will be staged to full capacity 20 seconds after Y2 input was received. The ECM blower will shift to high speed 15 seconds after the Y2 input was received.

Dual Compressor Cooling, 2nd Stage (Y1, Y2, O)

In dual compressor operation, two ABC boards used in 24 VAC operation, there will be a Y2 call to the Y1 input on the second ABC. The compressor will stage to full capacity 30 seconds after Y1 input is received to the second board.

Blower (G) - The blower will start immediately upon receiving a thermostat G command. If there are no other commands from the thermostat the ECM will run on "G" speed until the G command is removed. Regardless of blower input (G) from the thermostat, the blower will remain on for 30 seconds at the end of each heating, cooling, and emergency heat cycle.

Dehumidification (Y1, O, DH or Y1, Y2, O, DH) - When a DH command is received from the thermostat during a compressor call for cooling the ECM blower speed will be reduced by 15% to increase dehumidification.

Emergency Shutdown - Four (4) seconds after a valid ES input, P2-7 is present, all control outputs will be turned off and remain off until the emergency shutdown input is no longer present. The first time that the compressor is started after the control exits the emergency shutdown mode, there will be an anti-short cycle delay followed by a random start delay. Input must be tied to common to activate.

Continuous Blower Operation - The blower output will be energized any time the control has a G input present, unless the control has an emergency shutdown input present. The blower output will be turned off when G input is removed.

Load Shed - The LS input disables all outputs with the exception of the blower output. When the LS input has been cleared, the anti-short cycle timer and random start timer will be initiated. Input must be tied to common to activate.

Controls cont.

Aurora ‘Base’ Control LED Displays

These three LEDs display the status, configuration, and fault codes for the control. These can also be read in plain English via the Aurora AID Tool.

Status LED (LED3, Green)

| Description of Operation | Fault LED, Green |
|---------------------------|------------------|
| Normal Mode | ON |
| Control is Non-functional | OFF |
| Test Mode | Slow Flash |
| Lockout Active | Fast Flash |
| Dehumidification Mode | Flash Code 2 |
| (Future Use) | Flash Code 3 |
| (Future Use) | Flash Code 4 |
| Load Shed | Flash Code 5 |
| ESD | Flash Code 6 |
| (Future Use) | Flash Code 7 |

Configuration LED (LED2, Yellow)

| Description of Operation | Configuration LED, Yellow |
|----------------------------|---------------------------|
| No Software Overwritten | Flashing ECM Setting |
| DIP Switch was Overwritten | Slow Flash |
| ECM Configuration Mode | Fast Flash |

Fault LED (LED1, Red)

| Red Fault LED | | LED Flash Code* | Lockout | Reset/Remove |
|--------------------------------|------------------------------|-----------------|--------------|--------------|
| ABC Basic Faults | Normal - No Faults | OFF | - | |
| | Fault - Input | 1 | No | Auto |
| | Fault - High Pressure | 2 | Yes | Hard or Soft |
| | Fault - Low Pressure | 3 | Yes | Hard or Soft |
| | Fault - Freeze Detection FP2 | 4 | Yes | Hard or Soft |
| | Fault - Freeze Detection FP1 | 5 | Yes | Hard or Soft |
| | Fault - Condensate Overflow | 7 | Yes | Hard or Soft |
| | Fault - Over/Under Voltage | 8 | No | Auto |
| Fault - FP1 & FP2 Sensor Error | 11 | Yes | Hard or Soft | |

NOTE: All codes >11 use long flash for tens digit and short flash for the ones digit. 20, 30, 40, 50, etc. are skipped.

Aurora Interface and Diagnostics (AID) Tool

The Aurora Interface and Diagnostics (AID) Tool is a device that is a member of the Aurora network. The AID Tool is used to troubleshoot equipment which uses the Aurora control via Modbus RTU communication. The AID Tool provides diagnostics, fault management, ECM setup, and system configuration capabilities to the Aurora family of controls. An AID Tool is recommended, although not required, for ECM airflow settings. The AID Tool simply plugs into the exterior of the cabinet in the AID Tool port.



ABC Control Board Layout

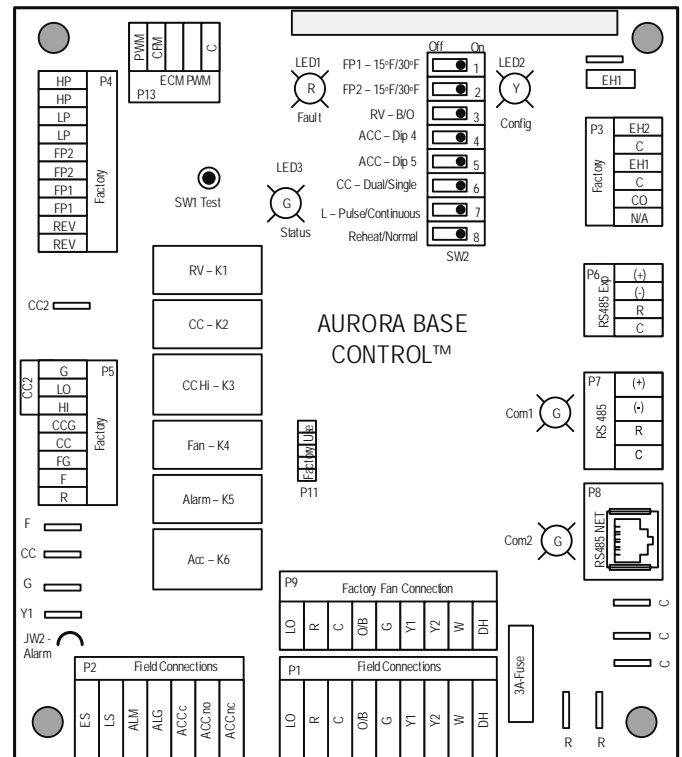

Controls cont.

Aurora ‘Advanced’ Control Features

The Aurora ‘Advanced’ Control system expands on the capability of the Aurora ‘Base’ Control (ABC) by adding the Aurora Expansion Board (AXB). All of the preceding features of the Aurora ‘Base’ Control are included. The following control description is of the additional features and capability of the Aurora advanced control.

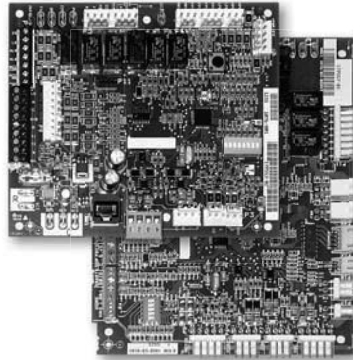

It is highly recommended the installing/servicing contractor obtain an Aurora Interface and Diagnostic Tool (AID) and specialized training before attempting to install or service an Aurora ‘Advanced’ control system.



The additional AXB features include the following:

AXB DIP Switch

DIP 1 - ID: This is the AXB ModBus ID and should always read On.

DIP 2 & 3 - Future Use

DIP 4 & 5 - Accessory Relay2: A second, DIP configurable, accessory relay is provided that can be cycled with the compressor 1 or 2, blower, or the Dehumidifier (DH) input. This is to complement the Accessory 1 Relay on the ABC board.

| Position | DIP 4 | DIP 5 | Description |
|----------|-------|-------|-------------------------------------------------------------------|
| 1 | ON | ON | Cycles with Fan or ECM (or G) |
| 2 | OFF | ON | Cycles with CC1 first stage of compressor or compressor spd 6 |
| 3 | ON | OFF | Cycles with CC2 second stage of compressor or compressor spd 7-12 |
| 4 | OFF | OFF | Cycles with DH input from ABC board |

Advanced Hot Water Generator Control (Domestic Hot Water Option)

In lieu of the ‘Base Hot Water Generator Control’, the Advanced features an AID Tool selectable temperature limit and microprocessor control of the process. This will maximize hot water generation and prevent undesirable energy use. An alert will occur when the hot water input temperature is at or above setpoint (100°F - 140°F) for 30 continuous seconds (130°F is the default setting). This alert will appear as an E15 on the AID Tool and the hot water pump de-energizes. Hot water pump operations resume on the next compressor cycle or after 15 minutes of continuous compressor operation during

the current thermostat demand cycle. Since compressor hot gas temperature is dependent on loop temperature in cooling mode, loop temperatures may be too low to allow proper heating of water. The control will monitor water and refrigerant temperatures to determine if conditions are satisfactory for heating water. LED1 (red LED) will flash code 15 when the DHW limit is reached and when conditions are not favorable for water heating. Error code 15 will also be displayed on the AID Tool in the fault screen. This flash code is a noncritical alert and does not necessarily indicate a problem.

Compressor Monitoring

The AXB includes two current transducers to monitor the compressor current and starting characteristics. Open circuits or welded contactor faults will be detected. A fault will produce an E10 code.

IntelliZone2 Zoning Compatibility (Optional IntelliZone2 Zoning)

A dedicated input to connect and communicate with the IntelliZone2 (IZ2) zoning system is provided on P7. This is a dedicated communication port using a proprietary ModBus protocol. An AXB can be added to other selected ABC-only systems as well. Then an advanced communicating IntelliZone2 zoning system can be added to ABC-only systems. Consult the IntelliZone2 literature for more information.

Variable Speed Pump

This input and output are provided to drive and monitor a variable speed pump. The VS pump output is a PWM signal to drive the variable speed pump. The minimum and maximum level are set using the AID Tool. 75% and 100% are the default settings respectively. The VS data input allows a separate PWM signal to return from the pump giving fault and performance information. Fault received from the variable speed pump will be displayed as E16.

Modulating Water Valve

This output is provided to drive a modulating water valve. Through advanced design the 0-10VDC valve can be driven directly from the VS pump output. The minimum and maximum level are set in the same way as the VS pump using the AID Tool. 75% and 100% are the default settings respectively.

Loop Pump Linking

This input and output are provided so that two units can be linked together with a common flow center. When either unit has a call for loop pump, both unit’s loop pump relays and variable speed pumps are energized. The flow center then can simply be wired to either unit. The output from one unit should be routed to the input of the other. If daisy chained up to 16 heat pumps can be wired and linked together in this fashion.

Controls cont.

Advanced Communication Ports

Communication ports P6 and P8 will provide future expansion via dedicated protocols. These are for future use.

Smart Grid-On Peak (SG) Input

The 'On Peak' input was designed to allow utilities to utilize simple radio controlled switches to control the On Electric Peak behavior of the 5 and 7 Series Geothermal Heat Pumps. With a closed contact signal, this input will limit the operation and thus the power consumption of the unit by one of the below selections. The AID Tool will allow configuration of this input for the action of:

- No Action
- Disable compressor operation until removed
- Go to On Peak thermostat settings until removed [Requires Com T-Stat] (Future Release)
- Compressor limited to 50% or low cap until removed [dual capacity or variable speed only] (Future Release)
- Disable compressor operation for 1/2 hr (can be removed immediately) (Future Release)

Then Flash Code 7 on the Green LED for the 'On Peak' mode. And On Peak will display on communicating thermostats.

Home Automation 1 and 2 Inputs

The Home automation inputs are simple closed contact inputs that will trigger an AID Tool and thermostat alert for the homeowner. These would require optional sensors and or equipment for connection to the AXB board. With two inputs two different sensors can be selected. The selected text will then be displayed on the AID Tool and communicating thermostats. These events will NOT alter functionality or operation of the heat pump/accessories and is for homeowner/service notification only.

Home Automation 1 - E23 HA1

With a closed dry contact signal, this input will cause an alarm and Alert Code 23 to indicate on the stat or flash on ABC. The AID Tool will allow configuration of this input between the following selections:

- No Action
- Home Automation Fault [no lockout info only]
 - Output from home automation system
- Security Alarm [no lockout info only]
 - Output from home security
- Sump Alarm Fault [no lockout info only]
 - Switch output from sump sensor
- Smoke/CO Alarm Fault [no lockout info only]
 - Switch output from Smoke/CO sensor
- Dirty Filter Alarm [no lockout info only]
 - Output from dirty filter sensor

Home Automation 2 - E24 HA2

With a closed dry contact signal, this input will cause an alarm and Alert Code 24 to indicate on the stat or flash on ABC. The AID Tool will allow configuration of this input between the following selections:

- No Action
- Home Automation Fault [no lockout info only]
 - Output from home automation system
- Security Alarm [no lockout info only]
 - Output from home security
- Sump Alarm Fault [no lockout info only]
 - Switch output from sump sensor
- Smoke/CO Alarm Fault [no lockout info only]
 - Switch output from Smoke/CO sensor
- Dirty Filter Alarm [no lockout info only]
 - Output from dirty filter sensor

Monitoring Sensor Kits

Energy Monitoring

(Standard Sensor Kit on 'Advanced' models)

The Energy Monitoring Kit includes two current transducers (blower and electric heat) added to the existing two compressor sensors so that the complete power usage of the heat pump can be measured. The AID Tool provides configuration detail for the type of blower motor and a line voltage calibration procedure to improve the accuracy. This information can be displayed on the AID Tool or selected communicating thermostats. The TPCM32U03/04 will display instantaneous energy use while the color touchscreen TPCC32U01 will in addition display a 13 month history in graph form.

Refrigerant Monitoring (optional sensor kit)

The optional Refrigerant Monitoring Kit includes two pressure transducers, and three temperature sensors, heating liquid line, suction temperature and existing cooling liquid line (FP1). These sensors allow the measurement of discharge and suction pressures, suction and liquid line temperatures as well as superheat and subcooling. This information will only be displayed on the AID Tool.

Performance Monitoring (optional sensor kit)

The optional Performance Monitoring Kit includes three temperature sensors, entering and leaving water, leaving air temperature and a water flow rate sensor. With this kit heat of extraction and rejection will be calculated. This requires configuration using the AID Tool for selection of water or antifreeze.

Controls cont.

Special Modes and Applications

5-Speed ECM Blower Motor

Normally the 5-Speed ECM motor can be driven off of thermostat signals and the ABC connector P9.

Communicating thermostats, however present a special problem in this application since they operate without 24 VAC thermostat signals. The ABC board is wired to operate these systems from the alternate relay output signals CC1, CC2, Fan, and EH1 and should be wired for this.

Communicating Digital Thermostats

The Aurora controls system also features either monochromatic or color touch screen graphic display thermostats for user interface. These displays not only feature easy to use graphical interface but display alerts and faults in plain English. Many of the features discussed here may not be applicable without these thermostats.

Dehumidification - Passive

In passive dehumidification mode, the airflow is reduced by 15% from the heating airflow setting. If cooling airflow is set to +5, -5 or -10% of heating airflow it will automatically be set to -15% of heating airflow whenever the dehumidification call is present in the communicating stat or from the thermostat input DH. If the airflow for cooling is already set to -15% no airflow change will be noticed from normal cooling. Dehumidification mode will be shown on the ABC and the communicating thermostats.

Aurora 'Advanced' Control LED Displays

These three LEDs display the status, configuration, and fault codes for the control. These can also be read in plain English via the Aurora AID Tool.

Status LED (LED3, Green)

| Description of Operation | Fault LED, Green |
|---------------------------|------------------|
| Normal Mode | ON |
| Control is Non-functional | OFF |
| Test Mode | Slow Flash |
| Lockout Active | Fast Flash |
| Dehumidification Mode | Flash Code 2 |
| Load Shed | Flash Code 5 |
| Emergency Shutdown | Flash Code 6 |
| On Peak Mode | Flash Code 7 |
| (Future Use) | Flash Code 8 |
| (Future Use) | Flash Code 9 |

Configuration LED (LED2, Yellow)

| Description of Operation | Configuration LED, Yellow |
|--------------------------|---------------------------|
| No Software Overwritten | ECM Setting |
| DIP Switch Overwritten | Slow Flash |
| ECM Configuration Mode | Fast Flash |
| Reset Configuration Mode | OFF |

Fault LED (LED1, Red)

| Red Fault LED | LED Flash Code * | Lockout | Reset/Remove | Fault Condition Summary | |
|---------------------------|----------------------------|---------|--------------|-----------------------------------------------------------------------|------------------------------------------------------------------------------|
| Normal - No Faults | Off | - | | | |
| ABC Basic Faults | Fault-Input | 1 | No | Auto | Tstat input error. Autoreset upon condition removal. |
| | Fault-High Pressure | 2 | Yes | Hard or Soft | HP switch has tripped (>600 psi) |
| | Fault-Low Pressure | 3 | Yes | Hard or Soft | Low Pressure Switch has tripped (<40 psi for 30 continuous sec.) |
| | Fault-Freeze Detection FP2 | 4 | Yes | Hard or Soft | Freeze protection sensor has tripped (<15 or 30 degF for 30 continuous sec.) |
| | Fault-Freeze Detection FP1 | 5 | Yes | Hard or Soft | Freeze protection sensor has tripped (<15 or 30 degF for 30 continuous sec.) |
| | Fault-Condensate Overflow | 7 | Yes | Hard or Soft | Condensate switch has shown continuity for 30 continuous sec. |
| | Fault-Over/Under Voltage | 8 | No | Auto | Instantaneous voltage is out of range. **Controls shut down until resolved. |
| | Fault-FP1 & 2 Snsr Error | 11 | Yes | Hard or Soft | If FP1 or 2 Sensor Error |
| ABC & AXB Advanced Faults | Fault-Compressor Monitor | 10 | Yes | Hard or Soft | Open Crkt, Run, Start or welded cont |
| | Non-CriticAXBSnsrErr | 13 | No | Auto | Any Other Sensor Error |
| | CriticAXBSnsrErr | 14 | Yes | Hard or Soft | Sensor Error for EEV or HW |
| | Alert-HotWtr | 15 | No | Auto | HW over limit or logic lockout. HW pump deactivated. |
| | Fault-VarSpdPump | 16 | No | Auto | Alert is read from PWM feedback. |
| | Not Used | 17 | No | Auto | IZ2 Com Fault. Autoreset upon condition removal. |
| | Non-CritComErr | 18 | No | Auto | Any non-critical com error |
| | Fault-CritComErr | 19 | No | Auto | Any critical com error. Auto reset upon condition removal |
| | Alarm - Low Loop Pressure | 21 | No | Auto | Loop pressure is below 3 psi for more than 3 minutes |
| | Alarm - Home Automation 1 | 23 | No | Auto | Closed contact input is present on Dig 2 input - Text is configurable |
| Alarm - Home Automation 2 | 24 | No | Auto | Closed contact input is present on Dig 3 input - Text is configurable | |

NOTES:

*All codes >11 use long flash for tens digit and short flash for the ones digit. 20, 30, 40, 50 etc. are skipped!

Alert' is a noncritical sensor or function that has failed. Normal operation of the heat pump is maintained but service is desired at some point.

Unit Startup Notes

Electrical Disconnect

Optional field installed console disconnect provides a permanent electrical connection to the main electrical supply branch. Wiring between the disconnect and the unit chassis is field supplied and allows the electrical power source to the chassis to be interrupted for unit servicing.

Non-Fused

Constructed of heavy gauge galvanized steel, the rocker style disconnect switch provides reliable electrical control. Wiring pigtailed, using 12-gauge wires, are factory installed to simplify field wiring.

Fused

Similar in construction to the non-fused electrical disconnect. The fused disconnect is available in five models with equipment rated fuses to provide additional circuit protection. The fuses are panel mounted to allow easy inspection and removal without removing the cover on the disconnect.

- CFD-10 - 10 amp rated fuse
- CFD-12 - 12 amp rated fuse
- CFD-15 - 15 amp rated fuse
- CFD-20 - 20 amp rated fuse
- CFD-25 - 25 amp rated fuse

The hydronic loop controller is a microprocessor based control panel for control of water loop heat rejector (tower), heat supplier (boiler), and/or water well pumps and circulation pumps. Includes audible and visual alarms, temperature indication, and add-on options of low switches, remote alarm sensor wells and pump alternator.

Hydronic Loop Controller for Boiler/Tower Installations

Unit Startup Checklist/Unit Startup Steps

Before Powering Unit, Check The Following:

- High voltage is correct and matches nameplate.
 - Fuses, breakers and wire size correct.
 - Low voltage wiring complete.
 - Piping completed and water system cleaned and flushed.
 - Air is purged from closed loop system.
 - Isolation valves are open, water control valves or loop pumps wired.
 - Condensate line open and correctly pitched.
 - Transformer switched to 208V if applicable.
 - Dip switches are set correctly, if applicable.
 - Blower rotates freely
 - Air filter is clean and in position.
 - Service/access panels are in place.
 - Return air temperature is between 50-80°F heating and 60-95°F cooling.
1. Check air coil cleanliness to ensure optimum performance. Clean as needed according to maintenance guidelines. To obtain maximum performance the air coil should be cleaned before startup. A 10-percent solution of dishwasher detergent and water is recommended for both sides of coil, a thorough water rinse should follow.

Startup Steps

Note: Complete the Equipment Start-Up/Commissioning Check Sheet during this procedure. Refer to thermostat operating instructions and complete the startup procedure.

1. Initiate a control signal to energize the blower motor. Check blower operation.
2. Initiate a control signal to place the unit in the cooling mode. Cooling setpoint must be set below room temperature.
3. Be sure that the compressor and water control valve or loop pump(s) are activated.
4. Verify that the water flow rate is correct by measuring the pressure drop through the heat exchanger using the P/T plugs and comparing to unit capacity data in specification catalog.
5. Check the temperature of both the supply and discharge water (Refer to Unit Operating Parameters tables).
6. Check for an air temperature drop of 15°F to 25°F across the air coil, depending on the fan speed and entering water temperature.
7. Adjust the cooling setpoint above the room temperature and verify that the compressor and water valve or loop pumps deactivate.
8. Initiate a control signal to place the unit in the heating mode. Heating set point must be set above room temperature.
9. Check the temperature of both the supply and discharge water (Refer to Unit Operating Parameters tables).
10. Check for an air temperature rise of 20°F to 35°F across the air coil, depending on the fan speed and entering water temperature.
11. Adjust the heating setpoint below room temperature and verify that the compressor and water valve or loop pump deactivate.
12. During all testing, check for excessive vibration, noise or water leaks. Correct or repair as required.
13. Set system to desired normal operating mode and set temperature to maintain desired comfort level.
14. Instruct the owner/operator in the proper operation of the thermostat and system maintenance.

Note: Be certain to fill out and forward all warranty registration papers.

Operating Parameters

| Entering Water Temp °F | Water Flow gpm/ton | Cooling | | | | | |
|------------------------|--------------------|-----------------------|-------------------------|-----------|------------|--------------------|---------------------|
| | | Suction Pressure psig | Discharge Pressure psig | Superheat | Subcooling | Water Temp Rise °F | Air Temp Drop °F DB |
| 30 | 1.5 | 100 - 115 | 170 - 190 | 17 - 26 | 10 - 14 | 18 - 22 | 20 - 30 |
| | 3.0 | 115 - 125 | 150 - 170 | 20 - 29 | 7 - 11 | 8 - 10 | 20 - 30 |
| 50 | 1.5 | 133 - 148 | 225 - 245 | 8 - 11 | 7 - 11 | 18 - 22 | 20 - 30 |
| | 3.0 | 129 - 144 | 185 - 205 | 8 - 11 | 6 - 10 | 8 - 10 | 20 - 30 |
| 70 | 1.5 | 139 - 154 | 300 - 320 | 6 - 10 | 6 - 10 | 18 - 22 | 18 - 26 |
| | 3.0 | 137 - 152 | 250 - 270 | 6 - 10 | 6 - 10 | 8 - 10 | 18 - 26 |
| 90 | 1.5 | 143 - 158 | 360 - 380 | 6 - 10 | 6 - 10 | 18 - 22 | 18 - 26 |
| | 3.0 | 141 - 156 | 330 - 350 | 6 - 10 | 6 - 10 | 8 - 10 | 18 - 26 |
| 110 | 2.3 | 143 - 158 | 360 - 380 | 6 - 10 | 6 - 10 | 18 - 22 | 18 - 22 |
| | 3.0 | 141 - 156 | 440 - 460 | 6 - 10 | 6 - 10 | 8 - 10 | 18 - 22 |

| Entering Water Temp °F | Water Flow gpm/ton | Heating | | | | | |
|------------------------|--------------------|-----------------------|-------------------------|-----------|------------|--------------------|---------------------|
| | | Suction Pressure psig | Discharge Pressure psig | Superheat | Subcooling | Water Temp Drop °F | Air Temp Rise °F DB |
| 30 | 1.5 | 73 - 79 | 305 - 330 | 7 - 13 | 7 - 11 | 7 - 10 | 20 - 26 |
| | 3.0 | 79 - 85 | 315 - 345 | 7 - 13 | 7 - 11 | 3 - 6 | 20 - 26 |
| 50 | 1.5 | 103 - 109 | 330 - 370 | 7 - 13 | 7 - 11 | 8 - 11 | 22 - 32 |
| | 3.0 | 115 - 130 | 350 - 380 | 7 - 13 | 7 - 11 | 4 - 7 | 22 - 32 |
| 70 | 1.5 | 145 - 155 | 375 - 410 | 7 - 13 | 7 - 11 | 11 - 14 | 28 - 38 |
| | 3.0 | 155 - 165 | 415 - 435 | 10 - 14 | 7 - 11 | 7 - 10 | 35 - 45 |
| 90 | 1.5 | 170 - 185 | 435 - 470 | 11 - 18 | 7 - 11 | 8 - 11 | 42 - 50 |
| | 3.0 | 174 - 190 | 465 - 500 | 11 - 18 | 7 - 11 | 8 - 11 | 42 - 50 |
| 110 | 2.3 | | | | | | |
| | 3.0 | | | | | | |

NOTES: Cooling performance based on entering air temperatures of 80°F DB, 67°F WB.
 Heating performance based on entering air temperature of 70°F DB.

6/20/11

Operating Limits

| Operating Limits | Cooling | | Heating | |
|--------------------------|-----------|---------|---------|------|
| | (°F) | (°C) | (°F) | (°C) |
| Air Limits | | | | |
| Min. Ambient Air | 45 | 7.2 | 45 | 7.2 |
| Rated Ambient Air | 80 | 26.7 | 70 | 21.1 |
| Max. Ambient Air | 100 | 37.8 | 85 | 29.4 |
| Min. Entering Air | 50 | 10.0 | 40 | 4.4 |
| Rated Entering Air db/wb | 80.6/66.2 | 27/19 | 68 | 20.0 |
| Max. Entering Air db/wb | 110/83 | 43/28.3 | 80 | 26.7 |
| Water Limits | | | | |
| Min. Entering Water | 30 | -1.1 | 20 | -6.7 |
| Normal Entering Water | 50-110 | 10-43.3 | 30-70 | -1.1 |
| Max. Entering Water | 120 | 48.9 | 90 | 32.2 |

NOTE: Minimum/maximum limits are only for start-up conditions, and are meant for bringing the space up to occupancy temperature. Units are not designed to operate at the minimum/maximum conditions on a regular basis. The operating limits are dependant upon three primary factors: 1) water temperature, 2) return air temperature, and 3) ambient temperature. When any of the factors are at the minimum or maximum levels, the other two factors must be at the normal level for proper and reliable unit operation.

Pressure Drop

| Model | GPM | Pressure Drop (psi) | | | | |
|-------|-----|---------------------|------|------|------|-------|
| | | 30°F | 50°F | 70°F | 90°F | 110°F |
| 09 | 1.2 | 1.0 | 0.9 | 0.8 | 0.7 | 0.6 |
| | 1.8 | 2.3 | 2.2 | 2.0 | 1.9 | 1.8 |
| | 2.5 | 3.8 | 3.7 | 3.5 | 3.3 | 3.1 |
| 12 | 1.5 | 0.9 | 0.8 | 0.7 | 0.6 | 0.5 |
| | 2.3 | 1.7 | 1.5 | 1.4 | 1.3 | 1.1 |
| | 3.5 | 3.0 | 2.7 | 2.5 | 2.4 | 2.2 |
| 15 | 2.0 | 1.7 | 1.6 | 1.5 | 1.4 | 1.3 |
| | 3.0 | 3.3 | 3.2 | 3.0 | 2.9 | 2.8 |
| | 4.5 | 5.7 | 5.5 | 5.3 | 5.1 | 4.9 |
| 18 | 3.0 | 1.7 | 1.6 | 1.5 | 1.4 | 1.3 |
| | 4.0 | 4.1 | 4.0 | 3.9 | 3.7 | 3.6 |
| | 5.5 | 7.9 | 7.6 | 7.4 | 7.2 | 6.9 |

6/10/13

Compressor and Thermistor Resistance

Compressor Resistance

| Model | 115/60/1 | | 208-230/60/1 | | 265/60/1 | |
|-------|-------------|-------------|--------------|-------------|-------------|-------------|
| | Run | Start | Run | Start | Run | Start |
| 09 | 0.77 - 0.89 | 1.79 - 2.05 | 3.65 - 4.19 | 3.75 - 4.31 | 3.73 - 4.27 | 4.45 - 5.13 |
| 12 | 0.77 - 0.89 | 1.79 - 2.05 | 3.35 - 3.85 | 2.80 - 3.22 | 3.73 - 4.27 | 4.45 - 5.13 |
| 15 | | | 2.74 - 3.16 | 2.60 - 3.00 | 3.03 - 3.49 | 2.39 - 2.75 |
| 18 | | | 2.24 - 2.58 | 2.84 - 3.26 | 3.03 - 3.49 | 2.39 - 2.75 |

6/10/13

Thermistor Resistance

| Thermistor Temperature (°F) | Microprocessor Resistance (Ohms) |
|-----------------------------|----------------------------------|
| 5 | 75757-70117 |
| 14 | 57392-53234 |
| 23 | 43865-40771 |
| 32 | 33809-31487 |
| 41 | 26269-24513 |
| 50 | 20570-19230 |
| 59 | 16226-15196 |
| 68 | 12889-12093 |
| 77 | 10310-9688 |
| 86 | 8300-7812 |
| 95 | 6723-6337 |
| 104 | 5480-5172 |
| 113 | 4490-4246 |
| 122 | 3700-3504 |
| 131 | 3067-2907 |
| 140 | 2554-2424 |
| 149 | 2149-2019 |

9/01/2015

Refrigerant Circuit Guideline

| Symptom | Head Pressure | Suction Pressure | Compressor Amp Draw | Superheat | Subcooling | Air Temp. Differential | Water Temp. Differential |
|-----------------------------------------------|-------------------------------------------------------------|------------------|---------------------|-------------|-------------|------------------------|--------------------------|
| Under Charged System (Possible Leak) | Low | Low | Low | High | Low | Low | Low |
| Over Charged System | High | High | High | Normal | High | Normal/Low | Normal |
| Low Air Flow Heating | High | High | High | High/Normal | Low | High | Low |
| Low Air Flow Cooling | Low | Low | Low | Low/Normal | High | High | Low |
| Low Water Flow Heating | Low/Normal | Low/Normal | Low | Low | High | Low | High |
| Low Water Flow Cooling | High | High | High | High | Low | Low | High |
| High Air Flow Heating | Low | Low | Low | Low | High | Low | Low |
| High Air Flow Cooling | Low | High | Normal | High | Low | Low | Normal |
| High Water Flow Heating | Normal | Low | Normal | High | Normal | Normal | Low |
| High Water Flow Cooling | Low | Low | Low | Low | High | Normal | Low |
| Low Indoor Air Temperature Heating | Low | Low | Low | Normal | High | Normal | Normal/High |
| Low Indoor Air Temperature Cooling | Low | Low | Low | Normal/Low | High | Low | Low |
| High Indoor Air Temperature Heating | High | High | High | Normal/High | Normal/Low | Low | Normal |
| High Indoor Air Temperature Cooling | High | High | High | High | Low | Low | High |
| Restricted TXV (Check Service Advisory) | High | Low | Normal/Low | High | High | Low | Low |
| Insufficient Compressor (Possible Bad Valves) | Low | High | Low | High | Normal/High | Low | Low |
| TXV - Bulb Loss of Charge | Low | Low | Low | High | High | Low | Low |
| Scaled Coaxial Heat Exchanger Heating | Low | Low | Low | Normal/Low | High | Low | Low |
| Scaled Coaxial Heat Exchanger Cooling | High | High | High | Normal/Low | Low | Low | Low |
| Restricted Filter Drier | Check temperature difference (delta T) across filter drier. | | | | | | |

7/6/10

Heat of Extraction/Rejection Data

| Model | gpm | Heat of Extraction (HE) | | | | Heat of Rejection (HR) | | | | |
|-------|-----|-------------------------|------|------|------|------------------------|------|------|------|-------|
| | | 30°F | 50°F | 70°F | 90°F | 30°F | 50°F | 70°F | 90°F | 110°F |
| 09 | 1.2 | | 6.2 | 8.1 | 10.6 | | 12.9 | 12.1 | 11.8 | |
| | 1.8 | 5.0 | 6.6 | 8.5 | 10.8 | 13.9 | 13.1 | 12.4 | 11.7 | 10.9 |
| | 2.5 | 5.0 | 6.9 | 9.0 | 10.9 | 14.0 | 13.4 | 12.6 | 11.8 | 11.0 |
| 12 | 1.5 | | 7.8 | 10.1 | 12.4 | | 15.2 | 14.4 | 13.9 | |
| | 2.3 | 6.3 | 8.1 | 10.4 | 12.6 | 16.3 | 15.4 | 14.6 | 13.9 | 12.9 |
| | 3.5 | 6.2 | 8.6 | 10.9 | 12.8 | 16.3 | 15.8 | 14.9 | 14.0 | 13.0 |
| 15 | 2.0 | | 10.3 | 12.4 | 16.4 | | 19.7 | 18.2 | 19.9 | |
| | 3.0 | 8.8 | 10.7 | 12.9 | 16.7 | 19.4 | 19.8 | 18.2 | 20.0 | 18.7 |
| | 4.5 | 7.4 | 11.3 | 13.7 | 17.0 | 19.5 | 19.9 | 18.2 | 20.2 | 18.9 |
| 18 | 3.0 | | 12.0 | 15.2 | 17.6 | | 23.8 | 22.0 | 20.7 | |
| | 4.0 | 9.5 | 12.2 | 15.5 | 17.9 | 23.4 | 23.9 | 21.9 | 20.7 | 19.4 |
| | 5.5 | 8.5 | 12.6 | 16.0 | 18.2 | 23.5 | 23.9 | 21.9 | 20.9 | 19.5 |

Data provided in MBtu/h

6/10/13

Reference Calculations

| Heating Calculations: | Cooling Calculations: |
|------------------------------------------|--------------------------------------------------|
| $LWT = EWT - \frac{HE}{gpm \times 500}$ | $LWT = EWT + \frac{HR}{gpm \times 500}$ |
| $LAT = EAT + \frac{HC}{cfm \times 1.08}$ | $LAT(DB) = EAT(DB) - \frac{SC}{cfm \times 1.08}$ |
| $TH = HC + HWC$ | $LC = TC - SC$ |
| | $S/T = \frac{SC}{TC}$ |

Legend

ABBREVIATIONS AND DEFINITIONS:

cfm = airflow, cubic feet/minute
 EWT = entering water temperature, Fahrenheit
 gpm = water flow in gallons/minute
 WPD = water pressure drop, psi and feet of water
 EAT = entering air temperature, Fahrenheit (dry bulb/wet bulb)
 HC = air heating capacity, MBtu/h
 TC = total cooling capacity, MBtu/h
 SC = sensible cooling capacity, MBtu/h
 KW = total power unit input, kilowatts
 HR = total heat of rejection, MBtu/h

HE = total heat of extraction, MBtu/h
 HWC = hot water generator capacity, MBtu/h
 EER = Energy Efficient Ratio = Btu output/Watt input
 COP = Coefficient of Performance = Btu output/Btu input
 LWT = leaving water temperature, °F
 LAT = leaving air temperature, °F
 TH = total heating capacity, MBtu/h
 LC = latent cooling capacity, MBtu/h
 S/T = sensible to total cooling ratio

DEALER: _____

PHONE #: _____ DATE: _____

PROBLEM: _____

MODEL #: _____

SERIAL #: _____

Startup/Troubleshooting Form

COOLING CYCLE ANALYSIS

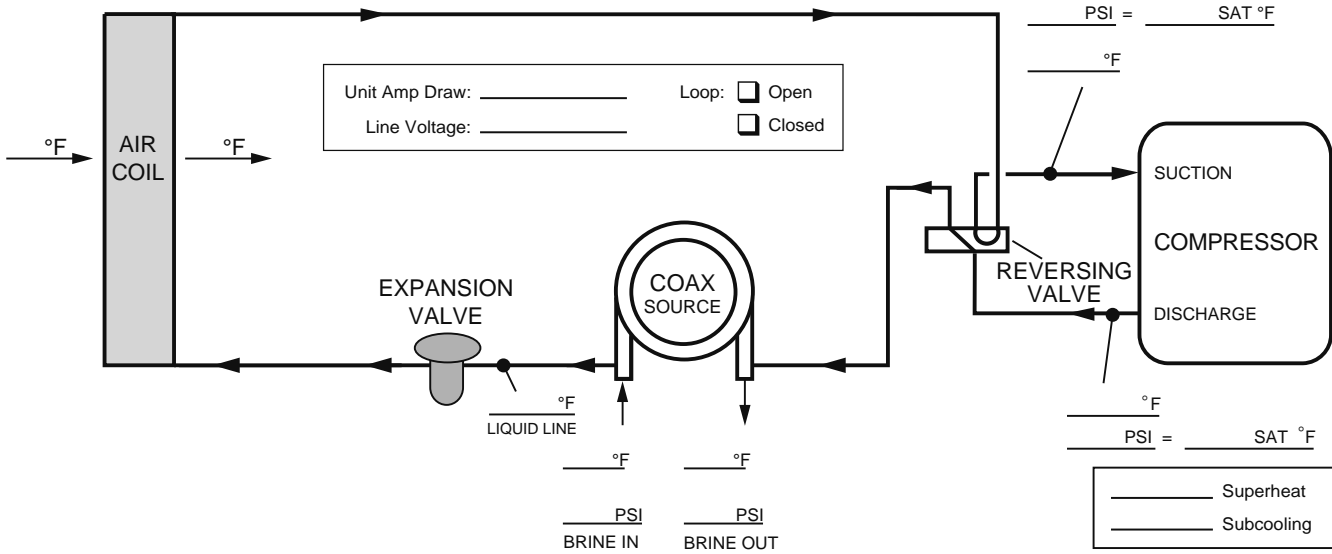

Heat of Extraction/Rejection = GPM x 500 (485 for water/antifreeze) x ΔT

Note: DO NOT hook up pressure gauges unless there appears to be a performance problem.

HEATING CYCLE ANALYSIS

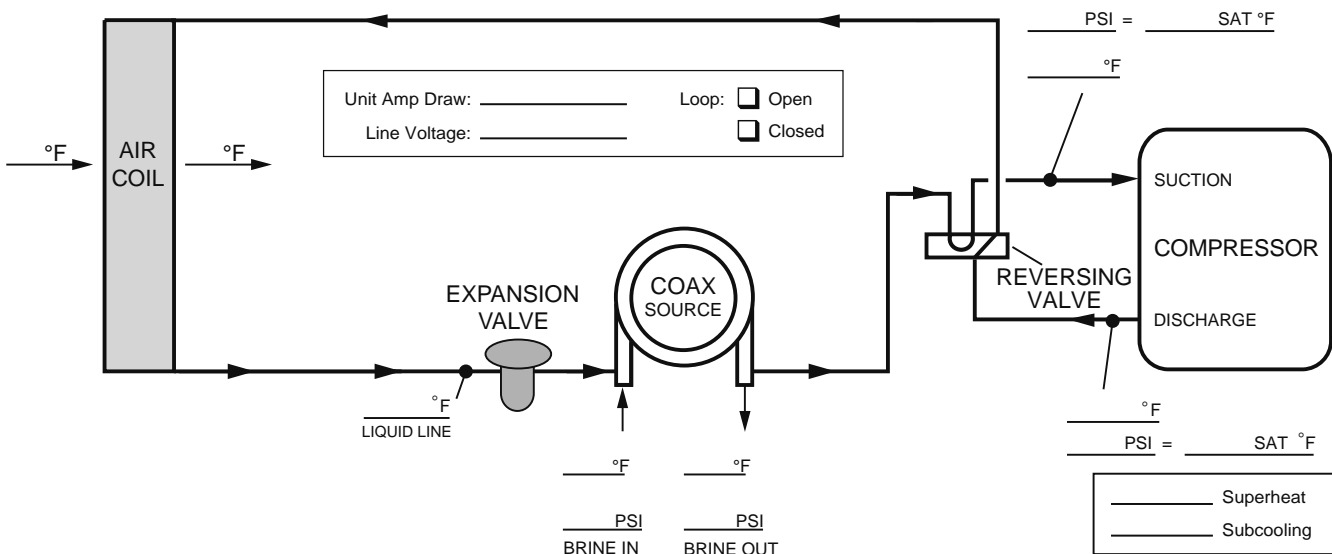

Preventive Maintenance

Water Coil Maintenance

1. Keep all air out of the water. An open loop system should be checked to ensure that the well head is not allowing air to infiltrate the water line. Lines should always be airtight.
2. Keep the system under pressure at all times. It is recommended in open loop systems that the water control valve be placed in the discharge line to prevent loss of pressure during off cycles. Closed loop systems must have positive static pressure.

Note: On open loop systems, if the installation is in an area with a known high mineral content (125 PPM or greater) in the water, it is best to establish with the owner a periodic maintenance schedule so the coil can be checked regularly. Should periodic coil cleaning be necessary, use standard coil cleaning procedures which are compatible with either the cupronickel or copper water lines. Generally, the more water flowing through the unit the less chance for scaling.

Other Maintenance

Filters

Filters must be clean to obtain maximum performance. They should be inspected monthly under normal operating conditions and be replaced when necessary. Units should never be operated without a filter.

Condensate Drain

In areas where airborne bacteria produce a slime in the drain pan, it may be necessary to treat chemically to minimize the problem.

The condensate drain can pick up lint and dirt, especially with dirty filters. Inspect twice a year to avoid the possibility of overflow.

Blower Motors

Blower motors are equipped with sealed ball bearings and require no periodic oiling.

Air Coil

The air coil must be cleaned to obtain maximum performance. Check once a year under normal operating conditions and, if dirty, brush or vacuum (with a brush attachment) clean. Care must be taken not to damage the aluminum fins while cleaning.



CAUTION: Fin edges are sharp.

Replacement Procedures

Obtaining Parts

When ordering service or replacement parts, refer to the model number and serial number of the unit as stamped on the serial plate attached to the unit. If replacement parts are required, mention the date of installation of the unit and the date of failure, along with an explanation of the malfunctions and a description of the replacement parts required.

In-Warranty Material Return

Material may not be returned except by permission of authorized warranty personnel. Contact your local distributor for warranty return authorization and assistance.

Service Parts List

| | | Low Sill Consoles | | | |
|--------------------------|---------------------------------------|-------------------|-----------|-----------|-----------|
| | | 09 | 12 | 15 | 18 |
| Compressor | Compressor 115/60/1 | 34P590-09 | 34P591-09 | N/A | N/A |
| | Compressor 208-230/60/1 | 34P590-01 | 34P591-01 | 34P592-01 | 34P593-01 |
| | Compressor 265/60/1 | 34P590-02 | 34P591-02 | 34P592-02 | 34P593-02 |
| | Run Capacitor 115/60/1 | 16P002D36 | 16P002D36 | N/A | N/A |
| | Run Capacitor 208-230/60/1 | 16P002D17 | 16P002D18 | 16P002D19 | 16P002D19 |
| | Run Capacitor 265/60/1 | 16P002D27 | 16P002D27 | 16P002D30 | 16P002D30 |
| | Sound Jacket | 92P504A01 | | | |
| PSC Motor & Blower | PSC Motor 115/60/1 | 14P506-03 | | N/A | |
| | PSC Motor 208-230/60/1 | 14P506-02 | | N/A | |
| | PSC Motor 265/60/1 | 14P506-02 | | N/A | |
| | Blower Housing | 53P518-02 | | N/A | |
| | Blower Capacitor 208-230/60/1 | 16P002D10 | | N/A | |
| | Blower Capacitor 265/60/1 | 16P002D37 | | N/A | |
| ECM Motor & Blower | ECM Motor 115/208-230/265/60/1 | N/A | | 14P549-01 | |
| | ECM Motor Module 115/208-230/265/60/1 | N/A | | 17P576-01 | |
| | Blower Housing | N/A | | 53P514B01 | |
| Refrigeration Components | Air Coil | 61P714-41 | | 61P724-41 | |
| | Coax | 62P558-03 | 62P559-03 | 62P560-01 | |
| | TXV | 33P605-09 | | 33P605-08 | |
| | Reversing Valve | 33P502-05 | | | |
| | Filter Drier | 36P500B01 | | | |
| Controls | CCM Board | 17P535-03 | | | |
| | ABC | 17P553-02 | | | |
| | Contactors | 13P004A03 | | | |
| Transformer | Transformer 208-230/60/1 | 15P514-01 | | | |
| | Transformer 265/60/1 | 15P515-01 | | | |
| Sensors & Safeties | High Pressure Switch | 35P506B02 | | | |
| | Low Pressure Switch | 35P506B01 | | | |

Part numbers subject to change

9/01/2015

Notes

Revision Guide

| Pages: | Description: | Date: | By: |
|---------------|--------------------------------------------------------|--------------|------------|
| All | Released ABC Control Option | 01 Sept 2015 | MA |
| 23-24, 43 | Updated Wiring Schematics, Updated Service Parts Table | 11 May 2015 | MA |
| All | Updated with All-Aluminum Air Coils | 10 Mar 2014 | DS |
| All | First Published | 11 Oct 2013 | DS |



Intertek

Product: **Aston Low Sill Series**
Type: Geothermal/Water Source Heat Pumps
Size: 0.75-1.5 Ton

Document Type: Installation Manual
Part Number: IM1012CGB
Release Date: 09/15