

ASTON CONSOLE SERIES

COMMERCIAL

Water Source/Geothermal Heat Pump

- R-410A Refrigerant
- Commercial 0.75-1.5 Ton

Installation Information

Water Piping Connections

Hot Water Connections

Electrical

Startup Procedures

Troubleshooting

Preventive Maintenance



GEOSTAR

Table of Contents

Model Nomenclature 4

General Installation Information 5

Dimensional Data 6-12

Installation Steps 13-16

System Cleaning and Flushing 17

Open Loop Ground Water Systems 18

Electrical Connections 19

Electrical Data 20

Auxiliary Heat Ratings 21

Blower Performance 21

Wiring Schematics 22-27

Controls 28

Startup Notes 36

Startup Checklist/Unit Startup Steps 37

Operating Parameters 38

Operating Limits 38

Startup/Troubleshooting Form 39

Pressure Drop 40

Preventive Maintenance 41

Replacement Procedures 41

Revision Guide 42

Model Nomenclature

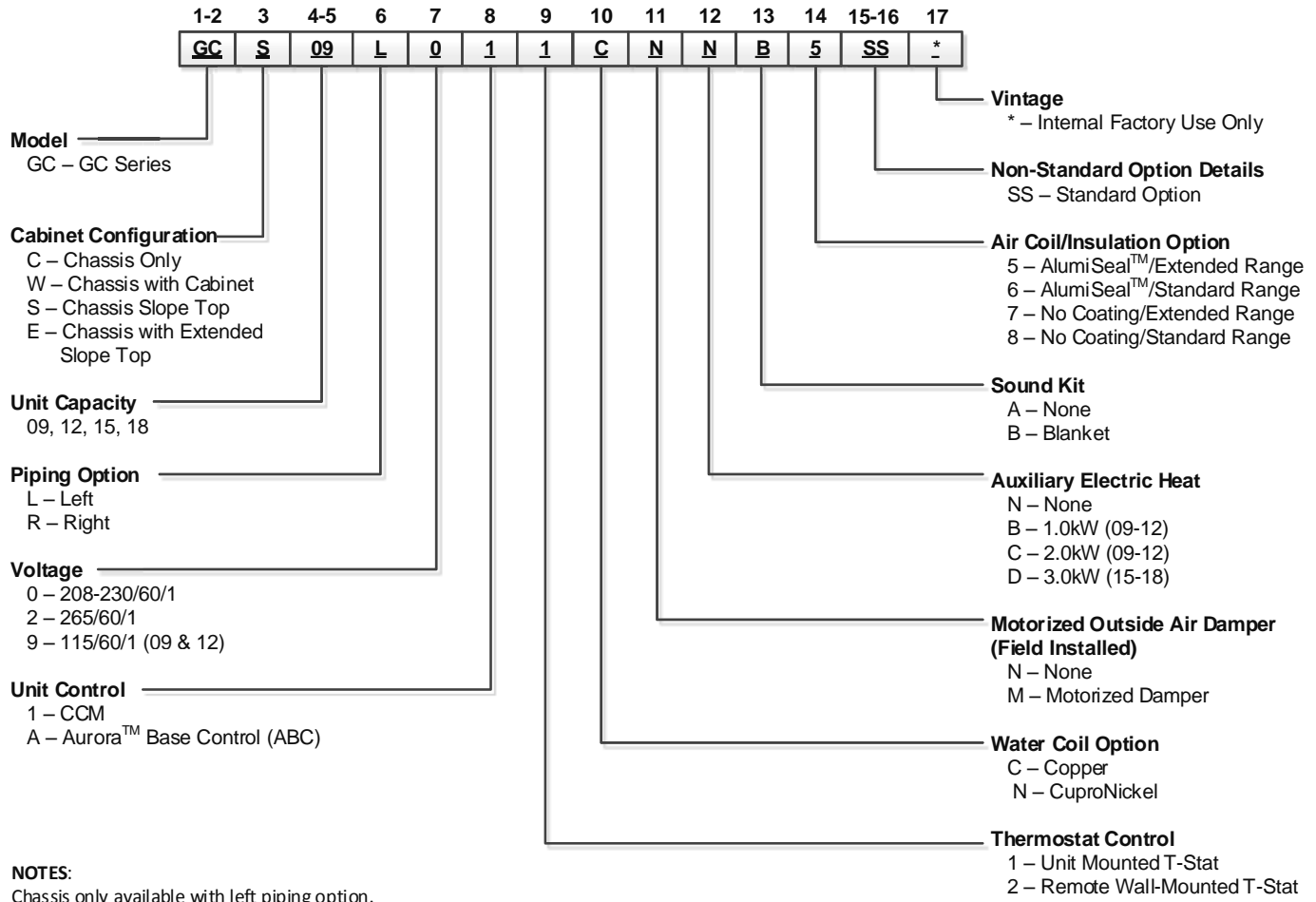

Voltage Availability

Voltage	Model			
	09	12	15	18
115/60/1	•	•		
208-230/60/1	•	•	•	•
265/60/1	•	•	•	•

1/20/14

General Installation Information

Safety Considerations



WARNING: Before performing service or maintenance operations on a system, turn off main power switches to the indoor unit. If applicable, turn off the accessory heater power switch. Electrical shock could cause personal injury.

Installing and servicing heating and air conditioning equipment can be hazardous due to system pressure and electrical components. Only trained and qualified service personnel should install, repair or service heating and air conditioning equipment. Untrained personnel can perform the basic maintenance functions of cleaning coils and cleaning and replacing filters. All other operations should be performed by trained service personnel. When working on heating and air conditioning equipment, observe precautions in the literature, tags and labels attached to the unit and other safety precautions that may apply.

Follow all safety codes. Wear safety glasses and work gloves. Use a quenching cloth for brazing operations and have a fire extinguisher available.

Moving and Storage

Move units in the normal "up" orientation. Do not stack units. When the equipment is received, all items should be carefully checked against the bill of lading to be sure all crates and cartons have been received. Examine units for shipping damage, removing the units from the packaging if necessary. Units in question should also be internally inspected. If any damage is noted, the carrier should make the proper notation on the delivery receipt, acknowledging the damage.

Water Piping

The proper water flow must be provided to each unit whenever the unit operates. To assure proper flow, use pressure/temperature ports to determine the flow rate. These ports should be located at the supply and return water connections on the unit. The proper flow rate cannot be accurately set without measuring the water pressure drop through the refrigerant-to-water heat exchanger.

All source water connections on commercial units are fittings that accept a male pipe thread (MPT). Insert the connectors by hand, then tighten the fitting with a wrench to provide a leakproof joint. When connecting to an open loop (groundwater) system, thread any copper MPT fitting into the connector and tighten in the same manner as described above.

Refrigerant Systems

To maintain sealed circuit integrity, do not install service gauges unless unit operation appears abnormal. Compare the change in temperature on the air side as well as the water side to the Unit Operating Parameters tables. If the unit's performance is not within the ranges listed, and the airflow and water flow are known to be correct, gauges should then be installed and superheat and subcooling numbers calculated. If superheat and subcooling are outside recommended ranges, an adjustment to therefrigerant charge may be necessary.

Dimensional Data - Flat Top Cabinet

GCW09-18

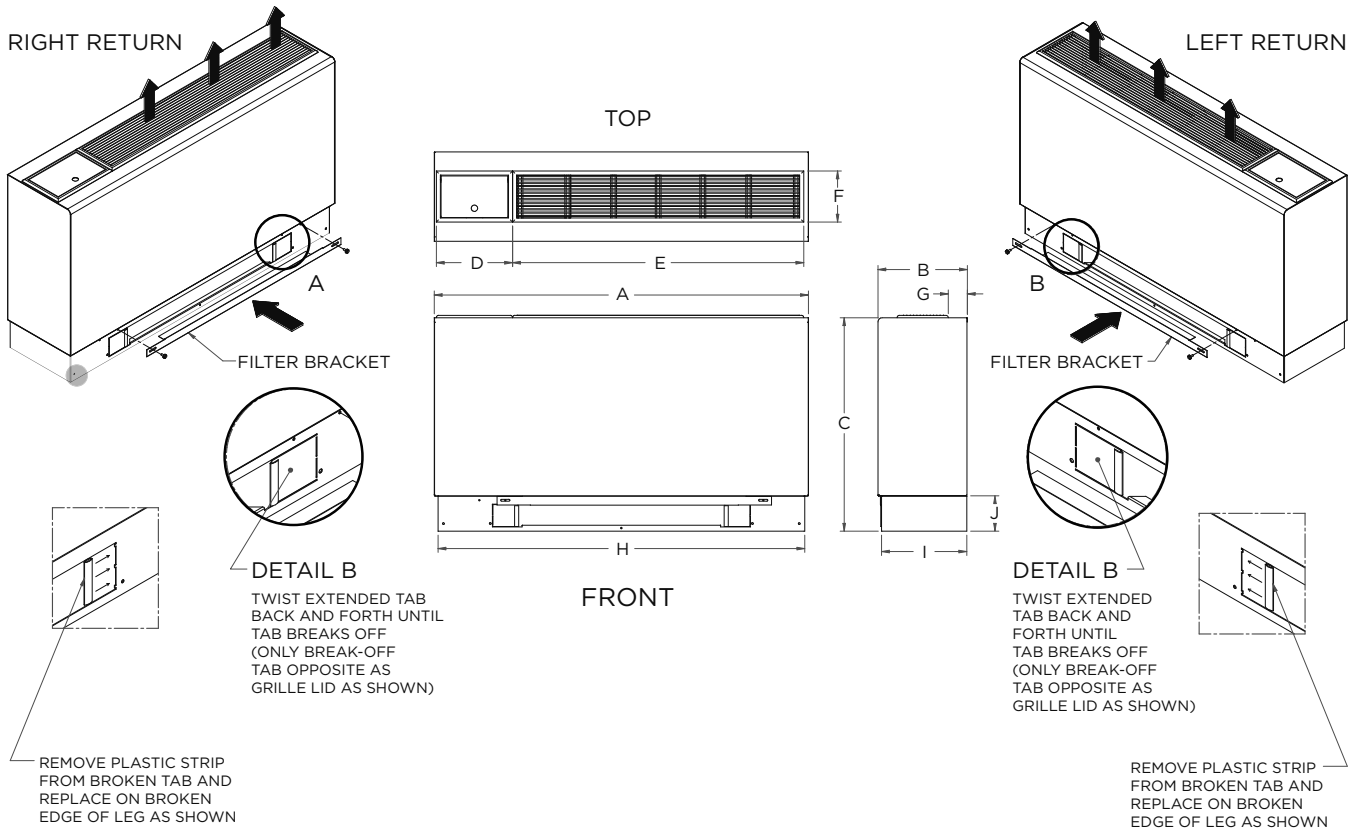

Flat Top Configuration		Overall Cabinet									
		A	B	C	D	E	F	G	H	I	J
		Width	Depth	Height	Grille Lid	Grille Length	Grille Width				
09-12	in.	45.0	10.8	25.7	9.2	35.0	6.1	2.3	44.1	10.3	4.3
	cm.	114.3	27.3	65.2	23.4	88.9	15.6	5.8	112.0	26.0	10.9
15-18	in.	50.0	12.3	25.7	9.2	35.0	6.1	3.3	49.1	11.8	4.3
	cm.	127.0	31.1	65.2	23.4	88.9	15.6	8.3	124.7	29.8	10.9

Dimensional Data - Slope Top Cabinet

GCS09-18

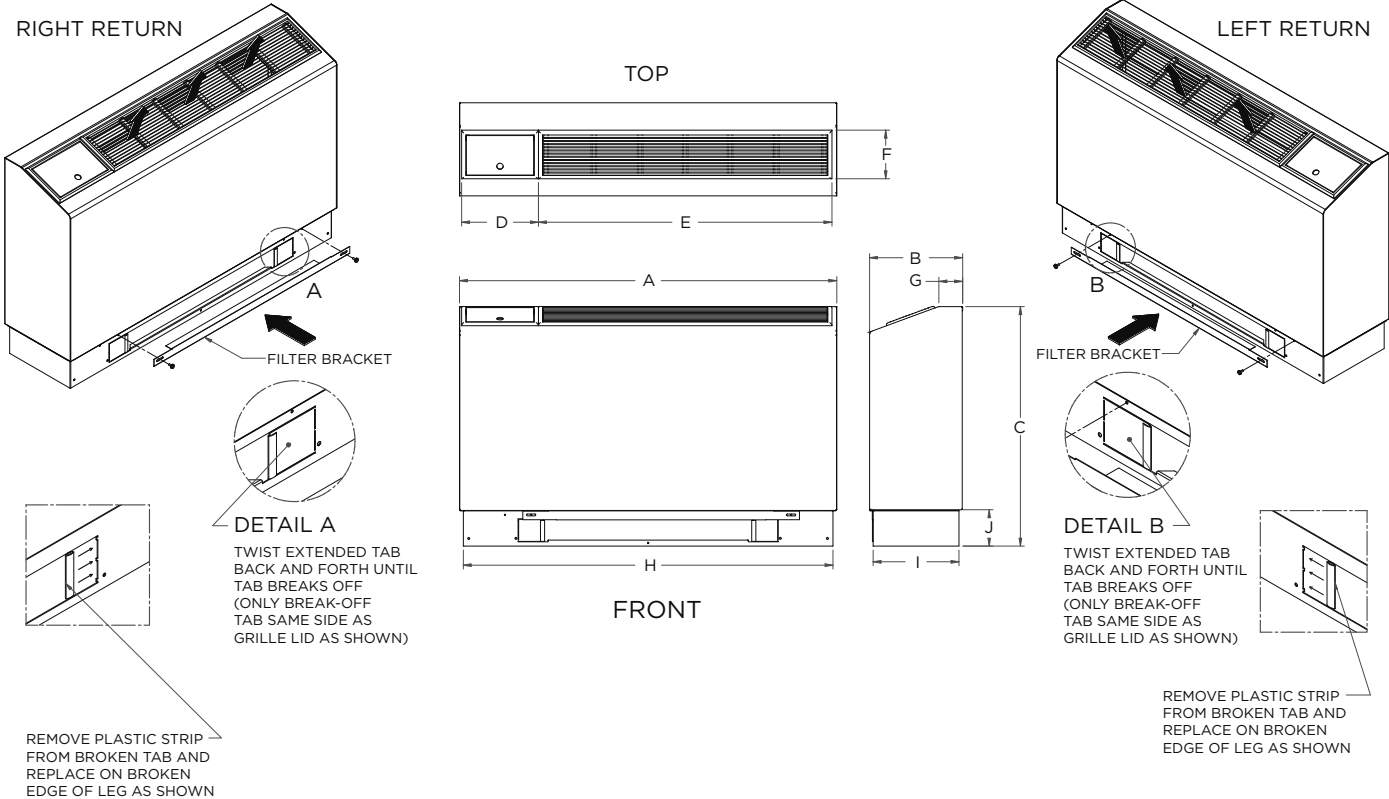

Slope Top Configuration		Overall Cabinet									
		A	B	C	D	E	F	G	H	I	J
		Width	Depth	Height	Grille Lid	Grille Length	Grille Width				
09-12	in.	45.0	11.1	28.6	9.2	35.0	6.1	2.8	44.1	10.3	4.3
	cm.	114.3	28.2	72.6	23.4	88.9	15.6	7.2	112.0	26.0	10.9
15-18	in.	50.0	12.6	29.1	9.2	35.0	6.1	2.5	49.1	11.8	4.3
	cm.	127.0	32.0	73.9	23.4	88.9	15.6	6.4	124.7	29.8	10.9

Dimensional Data - Extended Slope Top Cabinet

GCE09-18

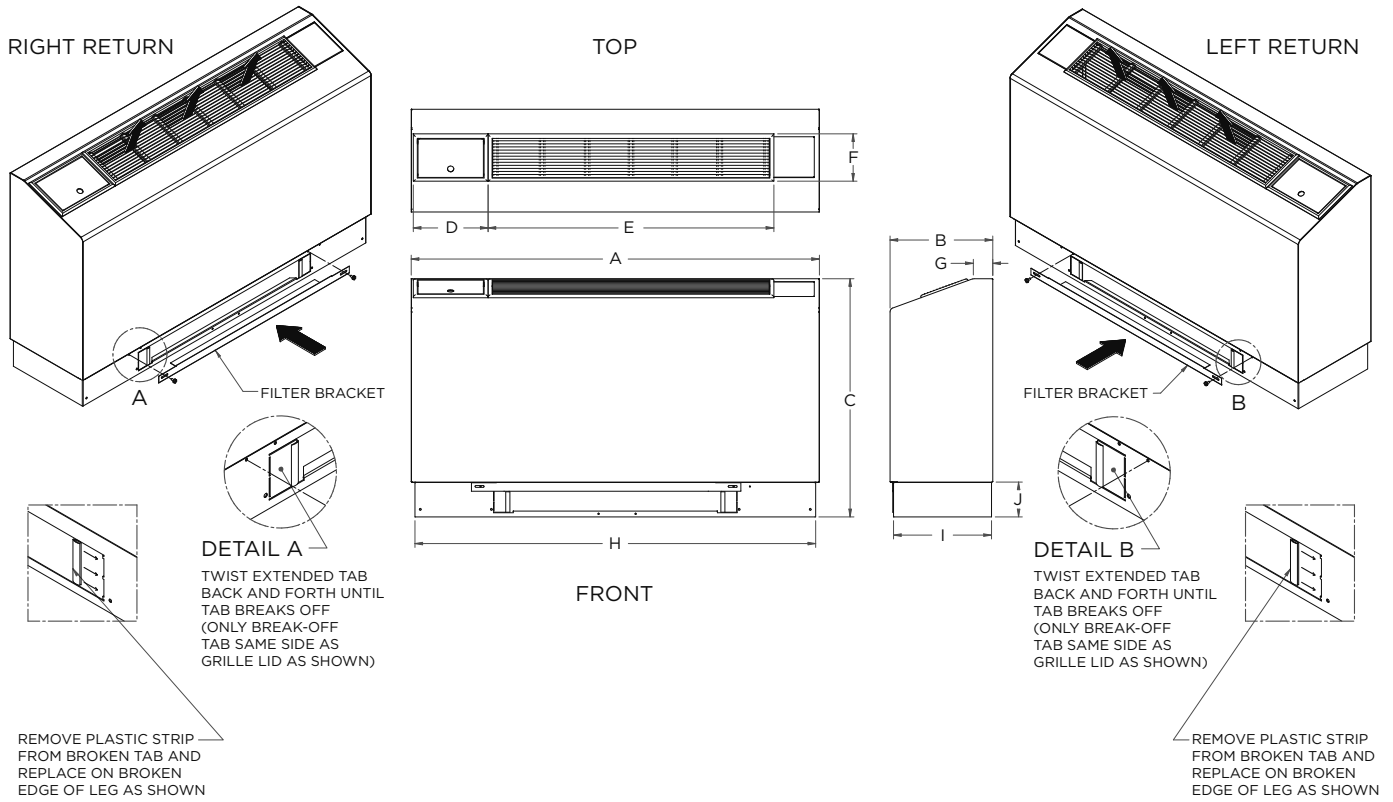

Ext. Slope Top Configuration		Overall Cabinet									
		A	B	C	D	E	F	G	H	I	J
		Width	Depth	Height	Grille Lid	Grille Length	Grille Width				
09-12	in.	50.0	12.6	29.1	9.2	35.0	6.1	2.4	49.1	12.0	4.3
	cm.	127.0	32.0	73.9	23.4	88.9	15.6	6.1	124.7	30.5	10.9
15-18	in.	55.0	12.6	29.1	9.2	35.0	6.1	2.5	54.1	11.8	4.3
	cm.	139.7	32.0	73.9	23.4	88.9	15.6	6.4	137.4	29.8	10.9

Dimensional Data - Right Return Controls Detail

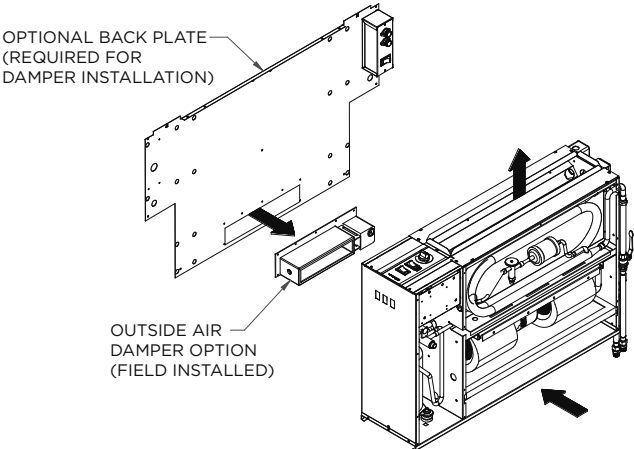
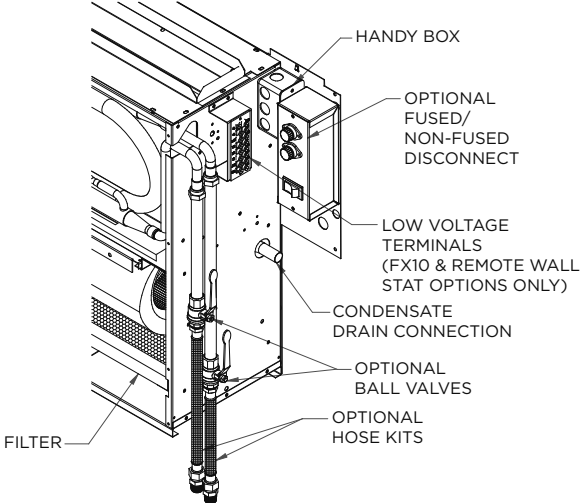
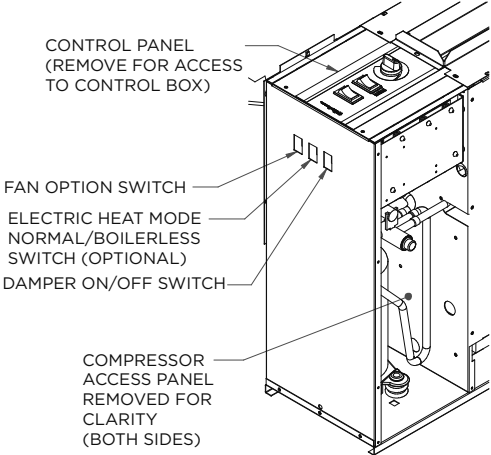

Dimensional Data - Right Return Chassis

Data = inches (cm)

Models 09-12

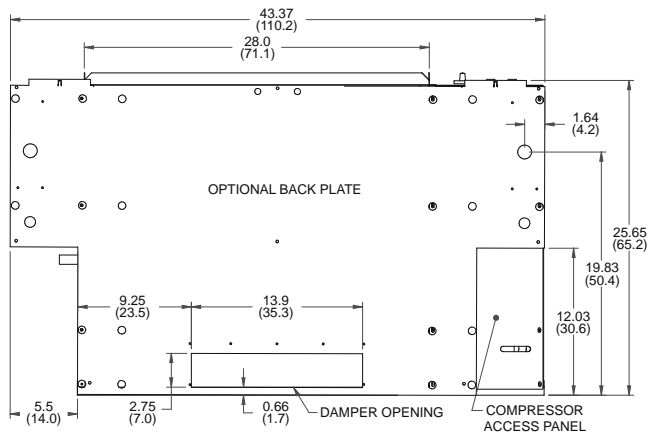
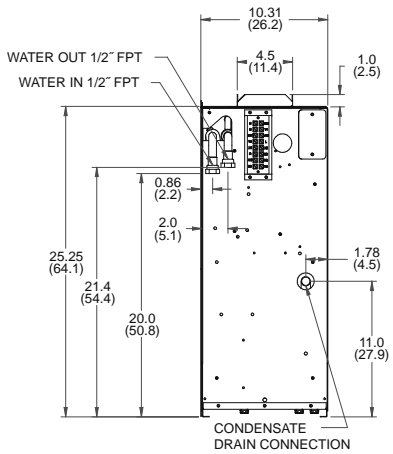
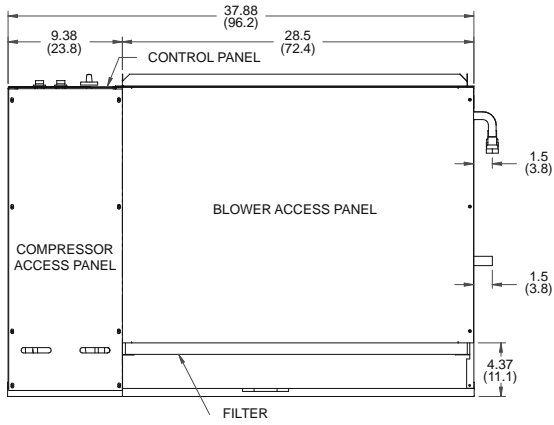

Models 15-18

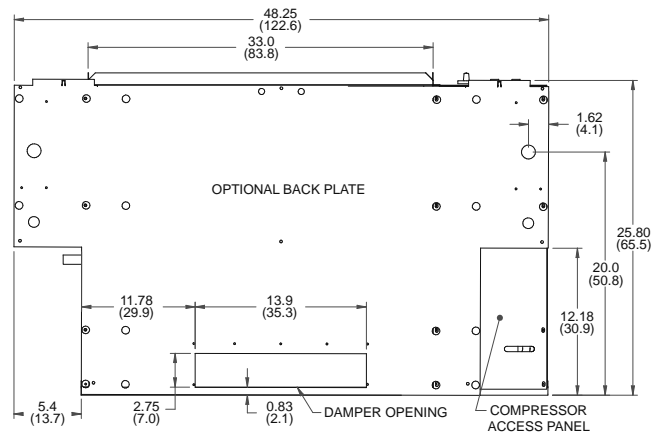
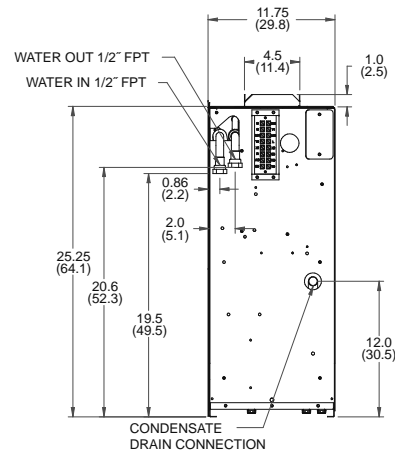
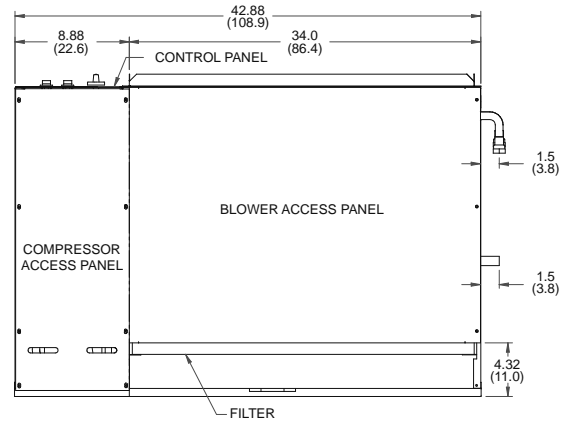

Dimensional Data - Left Return Controls Detail

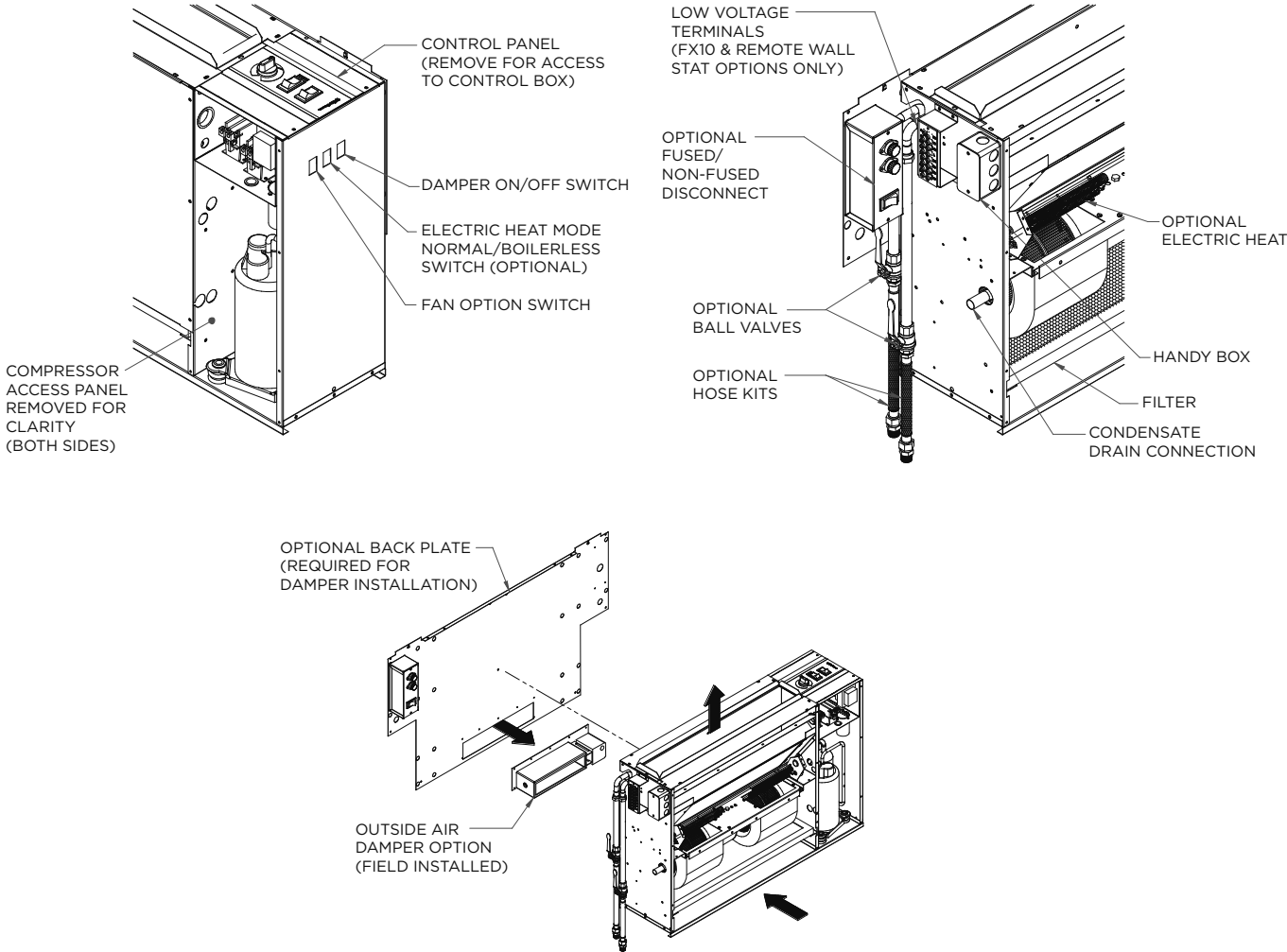

Dimensional Data - Left Return Chassis

Data = inches (cm)

Models 09-12

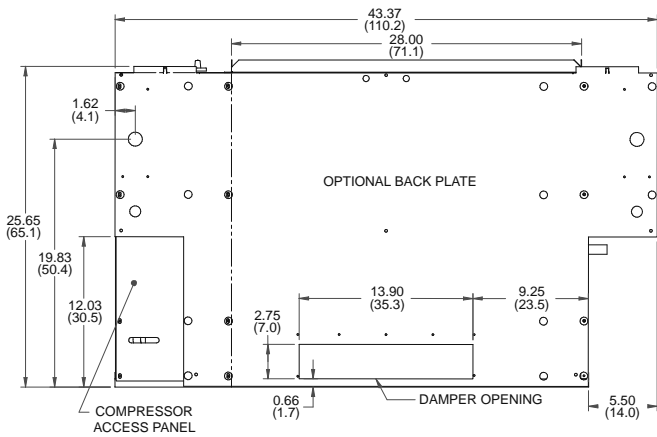
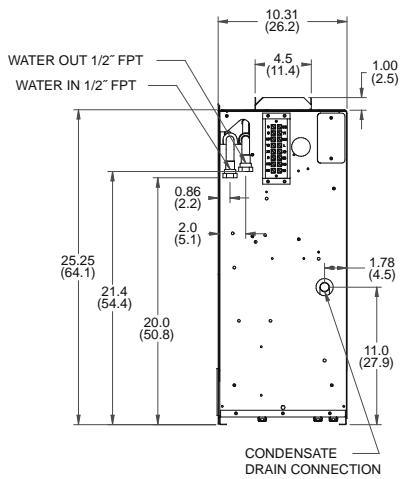
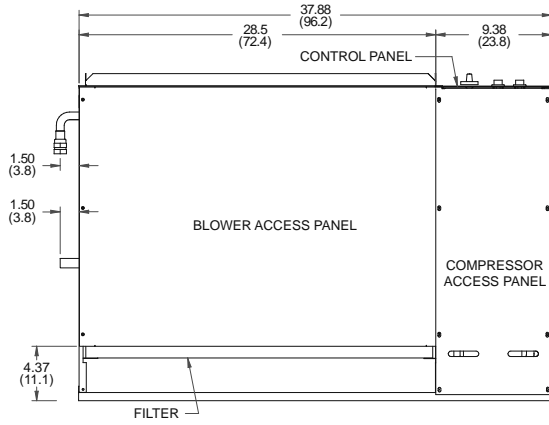

Models 15-18

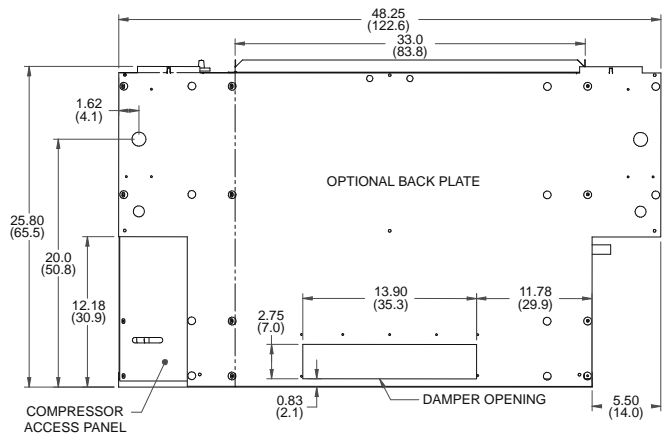
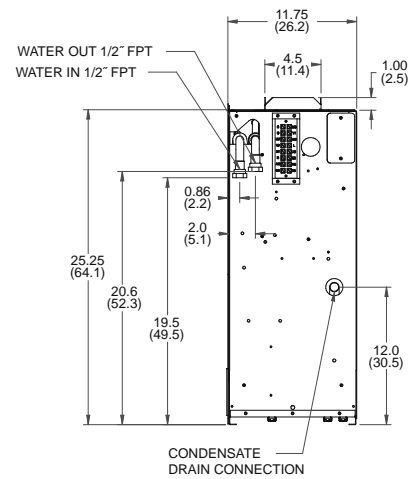
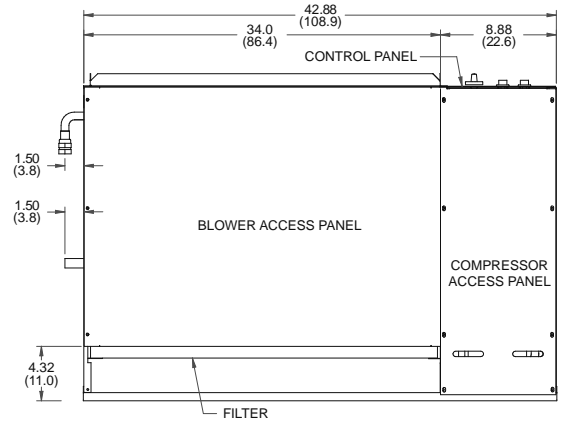

Installation Steps

Step 1: Unpack Equipment and Inspect for Damage

Step 2: Determine Equipment Location

- Choose level flooring surface (Correctable with shims. Do not pitch towards drain.)
- Location of wall support and fasteners required to secure chassis backplate.
- Easy access for both installation and service.
- Consider availability and ease of wiring, water piping and condensate drain.
- No obstructions to block airflow in front of the unit.

Step 3: Mark Unit Position

- Ensure that floor is level. If shims are required, make sure that the entire compressor compartment area is uniformly shimmed and that the backplate mounting height is increased by the thickness of the shims used.
- Position backplate in desired equipment location. To further reduce the operating sound level of the unit, 1/8-inch thick rubber matting may be placed under the chassis to eliminate vibration on hard flooring surfaces. (Make sure back plate is level).
- Mark and cut floor or wall penetrations for electrical wiring, water and condensate piping.

Optional Electrical Disconnect and Motorized Outside Air Damper

- Mark and cut wall penetrations for field fabricated outside air duct sleeve.
- Align mounting holes with backplate and attach with screws supplied.

Figure 1

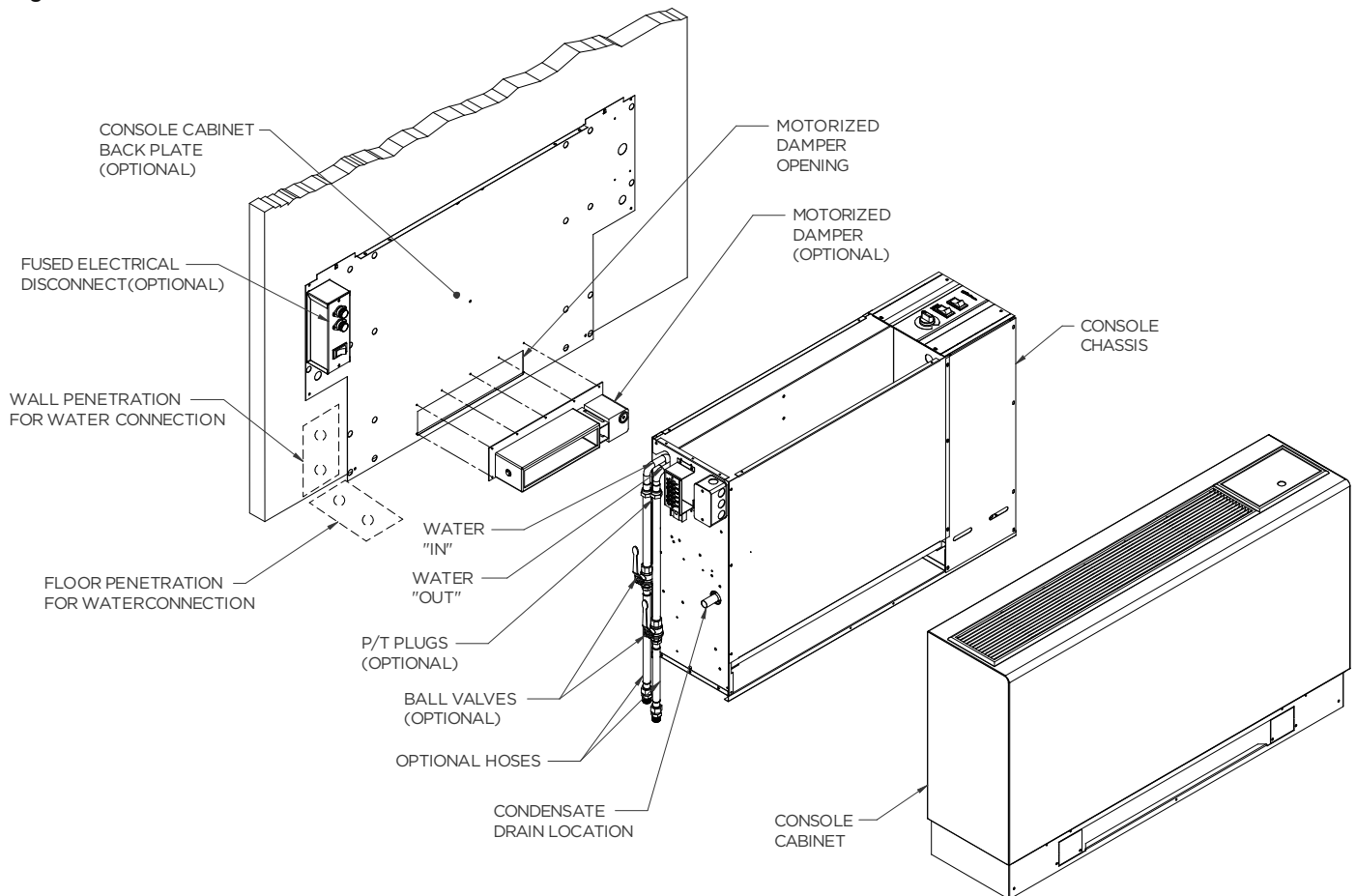

Installation Steps cont.

Step 4: Provide Water and Condensate Drain Connections

- A two-pipe reverse return piping configuration is recommended as it equalizes the piping circuit lengths and delivers even water flow to each unit. A direct return piping configuration may be used, but it may be difficult to achieve and maintain proper water flow to the units.
- An air vent must be installed in the water distribution system.
- The supply and return water piping should be run through the wall or floor penetration and terminate with a ball valve. The piping material used must comply with all local codes.
- Refer to: **System Cleaning and Flushing procedures.**

Pipe Locations

Figure 2

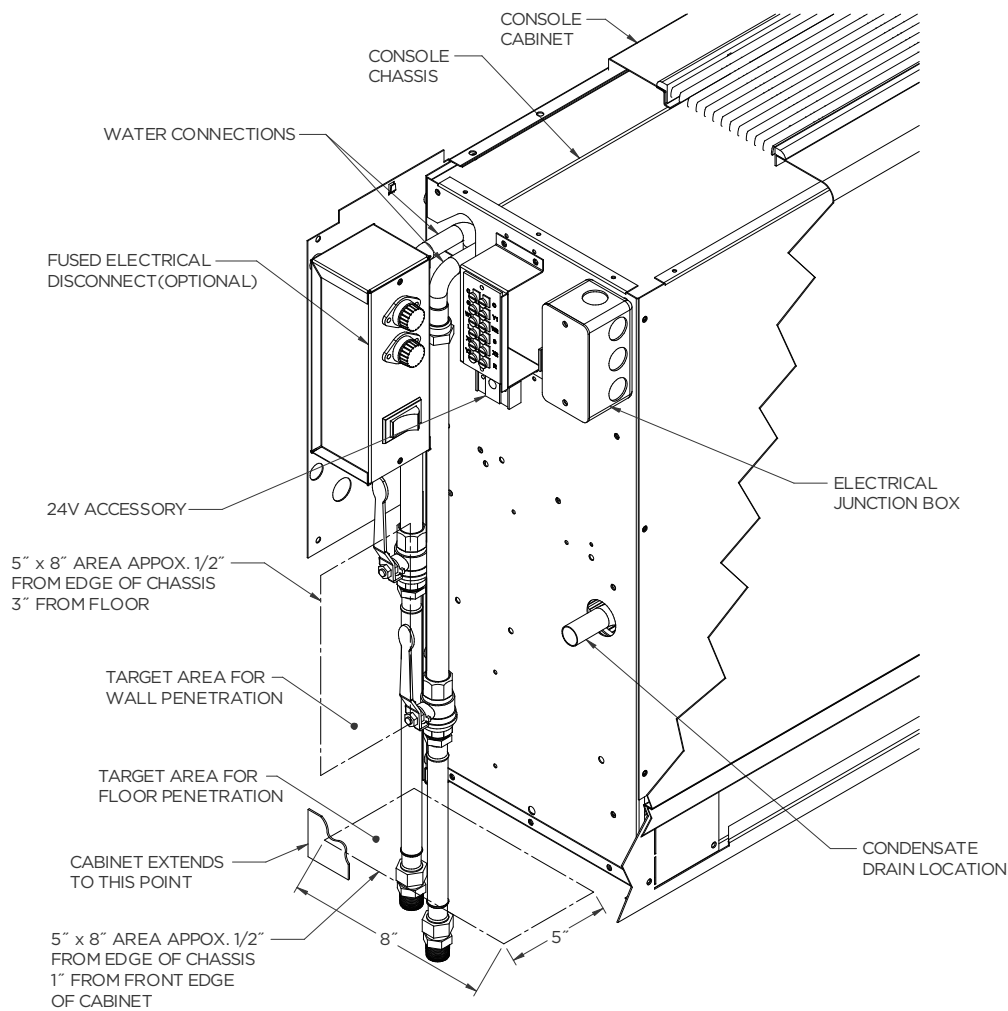

Installation Steps cont.

Step 5: Provide Line Voltage Wiring

- Check unit data plate located on control side of chassis for ampacity and fuse size.
- Remove electrical knockouts from chassis backplate.
- Run line voltage wiring through knockout and secure wiring to backplate or disconnect.

Step 6: Chassis Installation

- Remove air filter from console chassis and set aside. Remove the front air filter tabs on both sides of the return air opening by breaking them off using pliers.
- Depending upon the piping configuration of the chassis, remove the base foot cover tab by bending it back and forth until the tab breaks off. **Only remove the tab on the side opposite of where the controls grille lid is located.**
- Position and lower cabinet over unit chassis. Apply pressure to the front of the cabinet to ensure that the back lip of the cabinet hooks over the tabs provided on the backplate.
- Secure cabinet to chassis with mounting screws provided (small envelope taped to the control box panel).
- Reinstall the air filter so that the rear of the filter is supported by the back support tabs. Install the filter bracket with the two screws provided (the front of the filter is supported by the filter bracket when secured).

Step 7: Final Electrical Connection

- Install flexible electrical conduit between the backplate or electrical disconnect and the unit mounted junction box.
- Make final wiring connections in disconnect and junction box, taking care to replace all covers when done. Wiring must conform to NEC and/or all local codes. **Refer to Electrical Data.**

NOTE: It is necessary to make final wiring connections prior to securing unit chassis to back plate on right-hand piping models with electrical disconnect.

Step 8: Final Water Connection

- For ease of installation and sound attenuation, high pressure (recommended) flexible hoses with a swivel fitting should be provided. Apply Teflon® tape or sealant compound to threaded hose fittings.
- Combination shut-off/balancing valves should be installed on both the supply and return water lines of the unit.
- Flow control valves should be installed on the water discharge line.
- It is recommended that P/T ports be installed on the supply and return water lines.

Step 9: Set Unit Controls

- Locate the “continuous fan/cycle fan” switch within the electrical compartment of the chassis and set to desired position. (Remote wall thermostat units do not use this optional switch.)
- Optional Control Settings-
 - Remote Thermostat - Run low voltage wiring from unit to the desired thermostat location. Mount and wire thermostat according to manufacturer’s recommendations.
 - Motorized Outside Air Damper - Locate the “damper on/damper off” damper switch within the electrical compartment of the chassis and set to desired position.
 - Emergency Electrical Heat - Locate the “electric heat/normal/boilerless” control switch within the electrical compartment of the chassis and set to desired position.

Step 10: Secure the Cabinet Cover

- Position and lower cabinet over unit chassis. Apply pressure to the front of the cabinet to ensure that the back lip of the cabinet hooks over the tabs provided on the backplate.
- Secure cabinet to chassis with mounting screws provided.

Step 11: Perform Final Unit Check

- Measure the pressure drop across the water coil and monitor water or air temperatures in both heating and cooling modes. The measured values should fall within the acceptable ranges shown in the **Startup Performance table.**

Installation Steps cont.

Field Converting Console

Chassis is normally configured with controls on right end and piping on left end (see Figure 3 top view). In this position panel number 1 would be positioned against wall or back plate. Unit may also be turned 180° against wall or back plate. In this position controls will be on left end and piping on right end panel number 2 would be positioned against wall or back plate. Chassis must be enclosed with an approved cabinet enclosure.

Figure 3

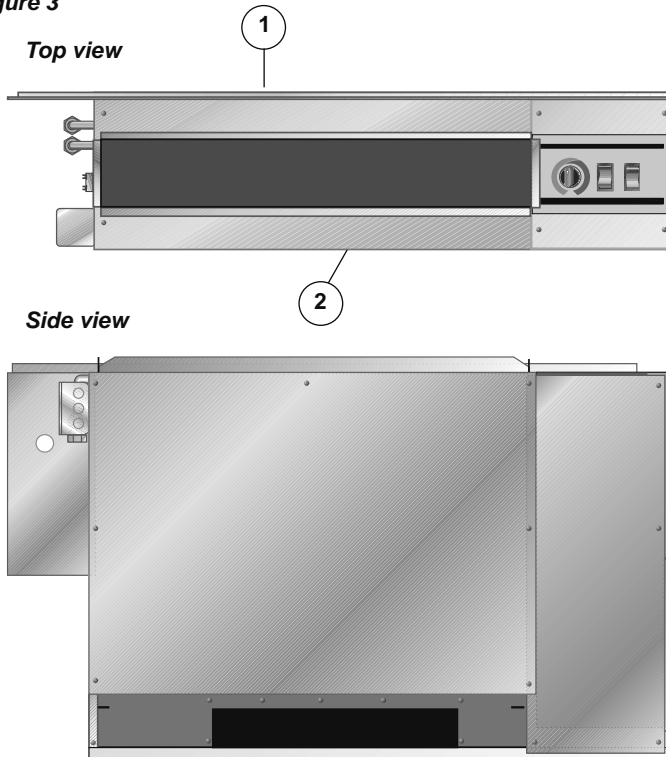

1. Remove 4 screws from front kick panel on cabinet.
2. Remove cabinet from chassis by lifting and sliding cabinet straight up.
3. Remove grille assembly from cabinet by removing 4 screws from brackets located on the bottom of the grille and door assemblies.
4. Replace grille/door assemblies into cabinet repositioning pieces 1, 2, and 3 into the locations directly opposite the original positions. Secure by replacing mounting brackets. (Note: Be sure that louvers on the grille assembly are facing the proper direction when replacing the grille section.)
5. Replace grille/frame assembly into cabinet, and secure by replacing mounting brackets.
6. Replace cabinet by sliding it down over the top of the chassis.
7. Remove tab on leg that extends into return air opening. When the grille side of the cabinet is flat against chassis there will be 4 holes that line up in the leg section. Only use 1 hole for alignment for opposite side of grille. (Note: The tab can be removed by twisting back and forth until it breaks off.)
8. Remove plastic strip from tab and replace on rough edge that the tab was removed from.
9. Replace screws in front kick panel to secure cabinet to chassis.
10. Mount filter bracket in designated opening area. (Note: The filter bracket will only fit in one direction if cabinet is installed properly.)

Figure 4

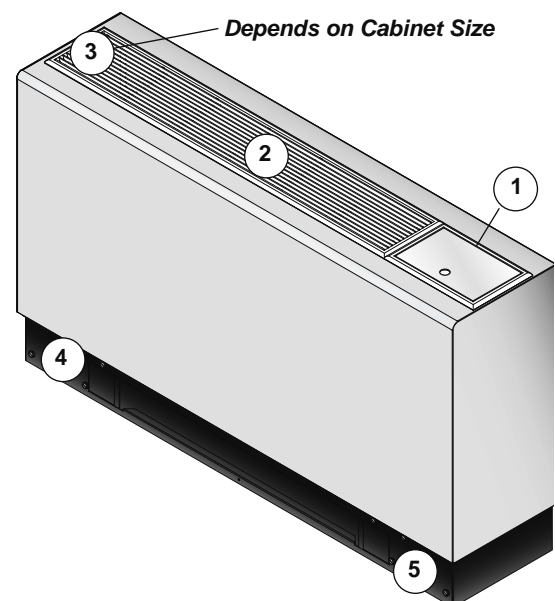

System Cleaning and Flushing

Cleaning and Flushing

Prior to start up of any heat pump, the water circulating system must be cleaned and flushed of all dirt and debris.

If the system is equipped with water shutoff valves, the supply and return runouts must be connected together at each unit location (This will prevent the introduction of dirt into the unit, see Figure 7). The system should be filled at the water make-up connection with all air vents open. After filling, vents should be closed.

The contractor should start the main circulator with the pressure reducing valve makeup open. Vents should be checked in sequence to bleed off any trapped air and to verify circulation through all components of the system.

As water circulates through the system, the contractor should check and repair any leaks found in the piping system. Drain(s) at the lowest point(s) in the system should be opened for initial flush and blowdown, making sure water fill valves are set at the same rate. Check the pressure gauge at the pump suction and manually adjust the make-up water valve to hold the same positive pressure both before and after opening the drain valves. Flushing should continue for at least two hours, or longer if required, until drain water is clean and clear.

The supplemental heater and/or circulator pump, if used, should be shut off. All drains and vents should be opened to completely drain the system. Short-circuited supply and return runouts should now be connected to the unit supply and return connections.

Refill the system with clean water. Test the system water for acidity and treat as required to leave the water slightly alkaline (pH 7.5 to 8.5). The specified percentage of antifreeze may also be added at this time. Use commercial grade antifreeze designed for HVAC systems only. Environol™ brand antifreeze is recommended.

Once the system has been filled with clean water and antifreeze (if used), precautions should be taken to protect the system from dirty water conditions. Dirty water will result in system-wide degradation of performance, and solids may clog valves, strainers, flow regulators, etc. Additionally, the heat exchanger may become clogged which reduces compressor service life and can cause premature unit failure.

In boiler/tower application, set the loop control panel set points to desired temperatures. Supply power to all motors and start the circulating pumps. After full flow has been established through all components including the heat rejector (regardless of season), air vented and loop temperatures stabilized, each of the units will be ready for check, test and start up and for air and water balancing.

Ground Source Loop System Checkout

Once piping is completed between the unit pumping system and ground loop, final purging and charging of the loop is needed. A high pressure pump is needed to achieve adequate flow velocity in the loop to purge air and dirt particles from the loop itself. Antifreeze solution is used in most areas to prevent freezing. Flush the system adequately to remove as much air as possible; then pressurize the loop to a static pressure of 40-50 PSI (summer) or 50-75 PSI (winter). This is normally adequate for good system operation. Loop static pressure may decrease soon after initial installation, due to pipe expansion and loop temperature change. Running the unit for at least 30 minutes after the system has been completely purged of air will allow for the "break-in" period. It may be necessary to adjust static loop pressure (by adding water) after the unit has run for the first time. Loop static pressure will also fluctuate with the seasons. Pressures will be higher in the winter months than during the cooling season. This fluctuation is normal and should be considered when charging the system initially.

Insure the pump provides adequate flow through the unit by checking pressure drop across the heat exchanger. Usually 2.25-3.0 GPM of flow per ton of cooling capacity is recommended in earth loop applications.

Figure 7: Flushing with Water Shutoff Valve Equipped Systems

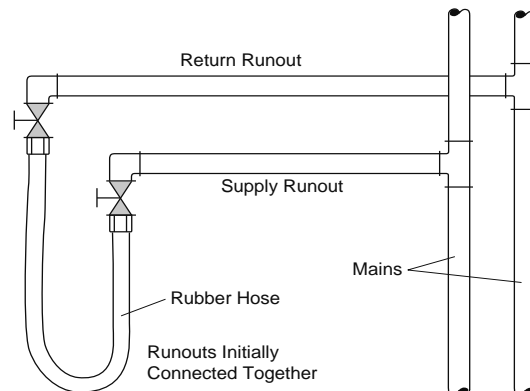

Open Loop Ground Water Systems

Always maintain water pressure in the heat exchanger by placing water control valves at the outlet of the unit to prevent mineral precipitation. Use a closed, bladder-type expansion tank to minimize mineral formation due to air exposure. Insure proper water flow through the unit by checking pressure drop across the heat exchanger and comparing it to the figures in unit capacity data tables in the specification catalog. 1.5-2 GPM of flow per ton of cooling capacity is recommended in open loop applications.

Discharge water from the unit is not contaminated in any manner and can be disposed of in various ways, depending on local codes, i.e. recharge well, storm sewer, drain field, adjacent stream or pond, etc. Most local codes forbid the use of sanitary sewer for disposal. Consult your local building and zoning departments to assure compliance in your area.

Note: For open loop/groundwater systems or systems that do not contain an antifreeze solution, set SW1-Switch #2 to the "WELL" position (Refer to the Dip Switch Field Selection table). Slow opening/closing solenoid valves (type VM) are recommended to eliminate water hammer.

Water Quality

In ground water situations where scaling could be heavy or where biological growth such as iron bacteria will be present, a closed loop system is recommended. The heat exchanger coils in ground water systems may, over a period of time, lose heat exchange capabilities due to a buildup of mineral deposits inside. These can be cleaned, but only by a qualified service mechanic, as special solutions and pumping equipment are required. Desuperheater coils can likewise become scaled and possibly plugged. In areas with extremely hard water, the owner should be informed that the heat exchanger may require occasional flushing.

Units with cupronickel heat exchangers are recommended for open loop applications due to the increased resistance to build-up and corrosion, along with reduced wear caused by acid cleaning.

Material		Copper	90/10 Cupronickel	316 Stainless Steel
pH	Acidity/Alkalinity	7 - 9	7 - 9	7 - 9
Scaling	Calcium and Magnesium Carbonate	(Total Hardness) less than 350 ppm	(Total Hardness) less than 350 ppm	(Total Hardness) less than 350 ppm
Corrosion	Hydrogen Sulfide	Less than 0.5 ppm (rotten egg smell appears at 0.5 ppm)	10 - 50 ppm	Less than 1 ppm
	Sulfates	Less than 125 ppm	Less than 125 ppm	Less than 200 ppm
	Chlorine	Less than 0.5 ppm	Less than 0.5 ppm	Less than 0.5 ppm
	Chlorides	Less than 20 ppm	Less than 125 ppm	Less than 300 ppm
	Carbon Dioxide	Less than 50 ppm	10 - 50 ppm	10 - 50 ppm
	Ammonia	Less than 2 ppm	Less than 2 ppm	Less than 20 ppm
	Ammonia Chloride	Less than 0.5 ppm	Less than 0.5 ppm	Less than 0.5 ppm
	Ammonia Nitrate	Less than 0.5 ppm	Less than 0.5 ppm	Less than 0.5 ppm
	Ammonia Hydroxide	Less than 0.5 ppm	Less than 0.5 ppm	Less than 0.5 ppm
	Ammonia Sulfate	Less than 0.5 ppm	Less than 0.5 ppm	Less than 0.5 ppm
	Total Dissolved Solids (TDS)	Less than 1000 ppm	1000 - 1500 ppm	1000 - 1500 ppm
	LSI Index	+0.5 to -0.5	+0.5 to -0.5	+0.5 to -0.5
Iron Fouling (Biological Growth)	Iron, FE ²⁺ (Ferrous) Bacterial Iron Potential	< 0.2 ppm	< 0.2 ppm	< 0.2 ppm
	Iron Oxide	Less than 1 ppm, above this level deposition will occur	Less than 1 ppm, above this level deposition will occur	Less than 1 ppm, above this level deposition will occur
Erosion	Suspended Solids	Less than 10 ppm and filtered for max. of 600 micron size	Less than 10 ppm and filtered for max. of 600 micron size	Less than 10 ppm and filtered for max. of 600 micron size
	Threshold Velocity (Fresh Water)	< 6 ft/sec	< 6 ft/sec	< 6 ft/sec

NOTES: Grains = ppm divided by 17
mg/L is equivalent to ppm

2/22/12

Electrical Connections

General

Be sure the available power is the same voltage and phase as that shown on the unit serial plate. Line and low voltage wiring must be done in accordance with local codes or the National Electric Code, whichever is applicable.

208 Volt Operation

All Envision Series 208/230 units are factory wired for 230 volt operation. For 208 volt operation, the red and blue transformer wires must be switched.

Microprocessor Remote Thermostat Wiring

Figure 5

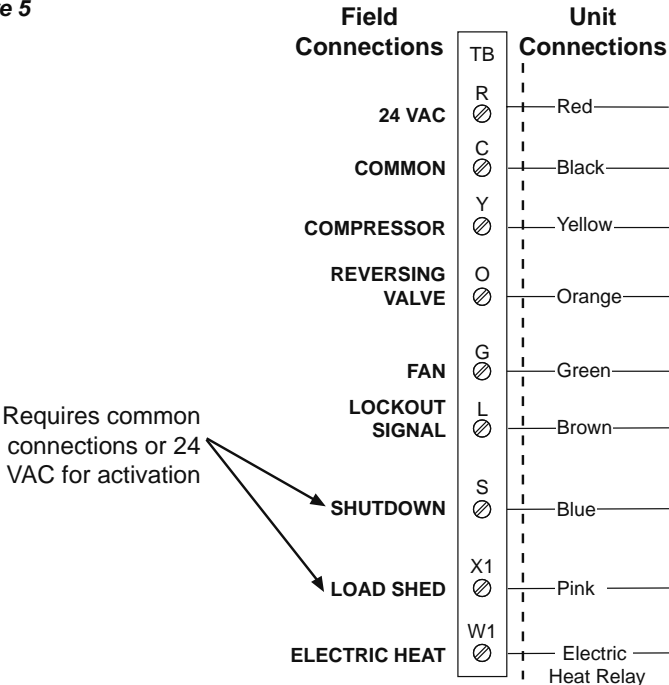

Electrical Data

ECM Motor

Model	Rated Voltage	Voltage Min/Max	Compressor			Fan Motor FLA	Total Unit FLA	Min Circ Amp	Max Fuse/HACR
			MCC	RLA	LRA				
09	115/60/1	104/127	12.5	8.0	50.0	4.25	12.3	14.3	20
	208-230/60/1	187/253	6.4	4.1	21.0	2.6	6.7	7.7	10/15
	265/60/1	238/292	6.7	4.3	22.0	2.5	6.8	7.9	10/15
12	115/60/1	104/127	14.8	9.5	50.0	4.25	13.8	16.1	25
	208-230/60/1	187/253	7.7	4.9	25.0	2.6	7.5	8.8	10/15
	265/60/1	238/292	7.0	4.5	22.0	2.5	7.0	8.1	10/15
15	208-230/60/1	187/253	9.2	5.9	29.0	2.6	8.5	10.0	15
	265/60/1	238/292	7.8	5.0	28.0	2.5	7.5	8.8	10/15
18	208-230/60/1	187/253	10.4	6.7	33.5	2.6	9.3	10.9	15
	265/60/1	238/292	8.7	5.6	28.0	2.5	8.1	9.5	15

HACR circuit breaker in USA only

1/20/14

Auxiliary Heat Ratings

ECM Motors

Model	Rated Voltage	Voltage Min./Max.	Heater Element Watts	Fan Motor FLA	Heater Element FLA	Total Unit FLA	Min. Circuit Amp.	Max. Fuse/Brkr.
09-12 (1 kW)	208/60/1	197/254	818	2.45	3.93	6.4	8.0	10
	230/60/1	197/254	1000	2.60	4.35	7.0	8.7	15
	265/60/1	239/291	1000	2.50	3.77	6.3	7.8	10
09-12 (2 kW)	208/60/1	197/254	1636	2.45	7.86	10.3	12.9	20
	230/60/1	197/254	2000	2.60	8.70	11.3	14.1	25
	265/60/1	239/292	2000	2.50	7.55	10.1	12.6	20
15-18 (3 kW)	208/60/1	197/254	2454	2.45	11.80	14.3	17.8	30
	230/60/1	197/254	3000	2.60	13.04	15.6	19.6	35
	265/60/1	239/292	3000	2.50	11.32	13.8	17.3	30

Always refer to unit nameplate data prior to installation.

10/5/10

Blower Performance Data

ECM Motors

Model	CFM		
	Low Speed	Medium Speed	High Speed
09	300	325	400
12	300	325	400
15	350	450	600
18	350	450	600

For wet coil performance first calculate the face velocity of the air coil (Face Velocity [fpm] = Airflow [cfm] / Face Area [sq ft]). Then for velocities of 200 fpm reduce the static capability by 0.03 in. wg, 300 fpm by 0.08 in. wg, 400 fpm by 0.12in. wg. and 500 fpm by 0.16 in. wg.

Wiring Schematics

CCM - with ECM Motor and Electronic Stat

208-230-265/60/1

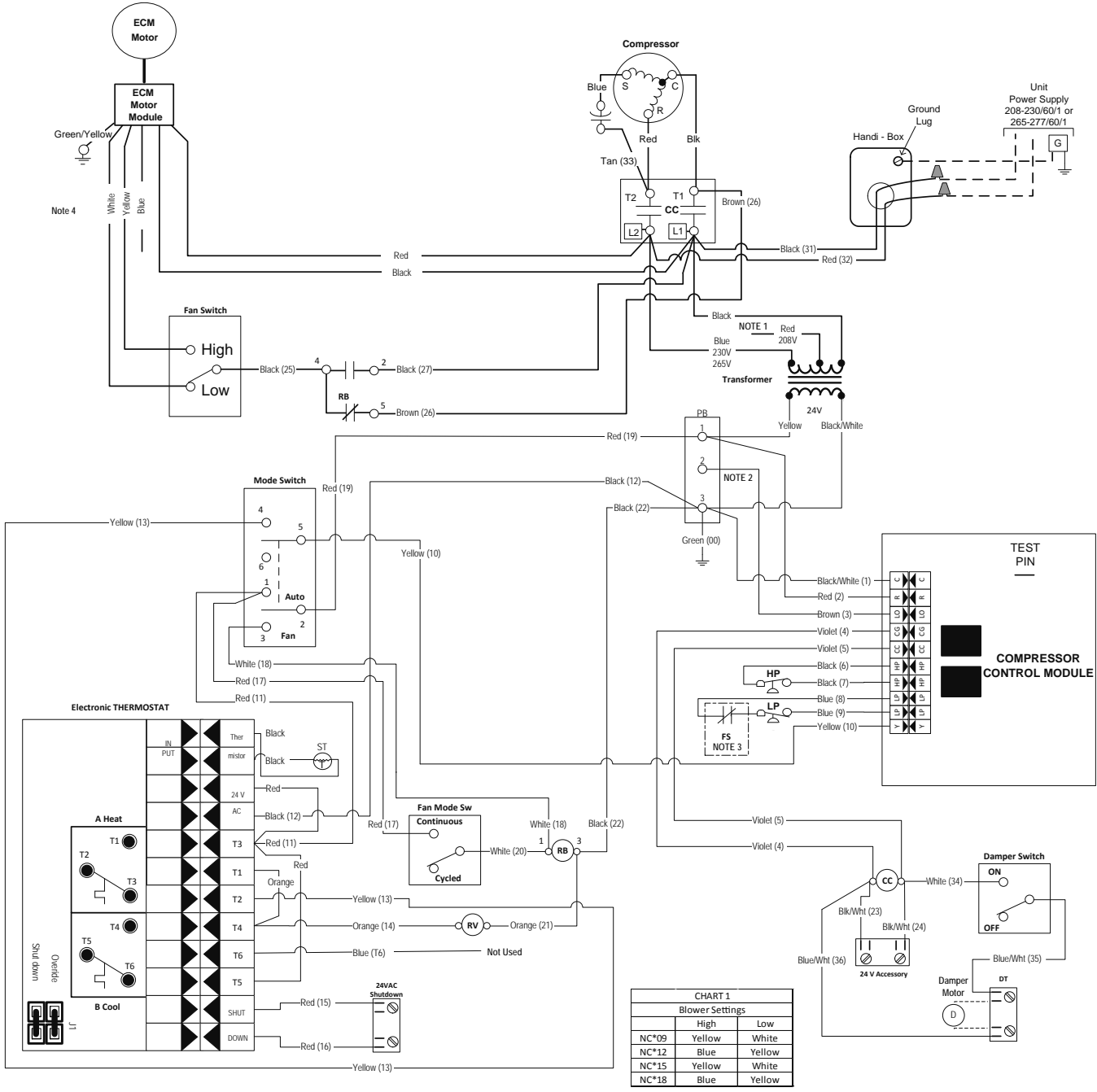

CHART 1

	Blower Settings	
	High	Low
NC*09	Yellow	White
NC*12	Blue	Yellow
NC*15	Yellow	White
NC*18	Blue	Yellow

Legend

<p>— Factory low voltage wiring</p> <p>— Factory line voltage wiring</p> <p>- - - Field low voltage wiring</p> <p>- - - Field line voltage wiring</p> <p>○ Quick connect terminal</p> <p>▲ Wire nut</p>	<p>CC - Compressor Contactor</p> <p>DT - Damper Terminal Block</p> <p>FS - Freeze Sensing Device</p> <p>HP - High Pressure Switch</p> <p>LP - Low Pressure Switch</p> <p>PB - Power Block</p> <p>RB - Blower Relay</p> <p>RV - Reversing Valve Coil</p> <p>ST - Entering Air Temperature Sensor</p>	<p>L1 Field wire lug</p> <p>Earth Ground</p> <p>Relay Contacts - N.O., N.C.</p> <p>Polarized connector</p>	<p>HP Switch - High Pressure</p> <p>LP Switch - Low Pressure</p> <p>Relay coil</p> <p>Capacitor</p> <p>Thermistor</p> <p>Temperature Switch</p>	<p>Notes:</p> <ol style="list-style-type: none"> 1. Switch Red and Blue wires for 208 volt operation 2. Terminal C of 24 V PB is used as "L" output for Brown wire 3 for Lockout. 3. Optional field installed freeze sensing device. 4. Factory wired. Refer to blower table settings.
---	---	--	---	---

Wiring Schematics, cont.

CCM - with ECM, Electric Heat and Electronic Stat

208-230-265/60/1

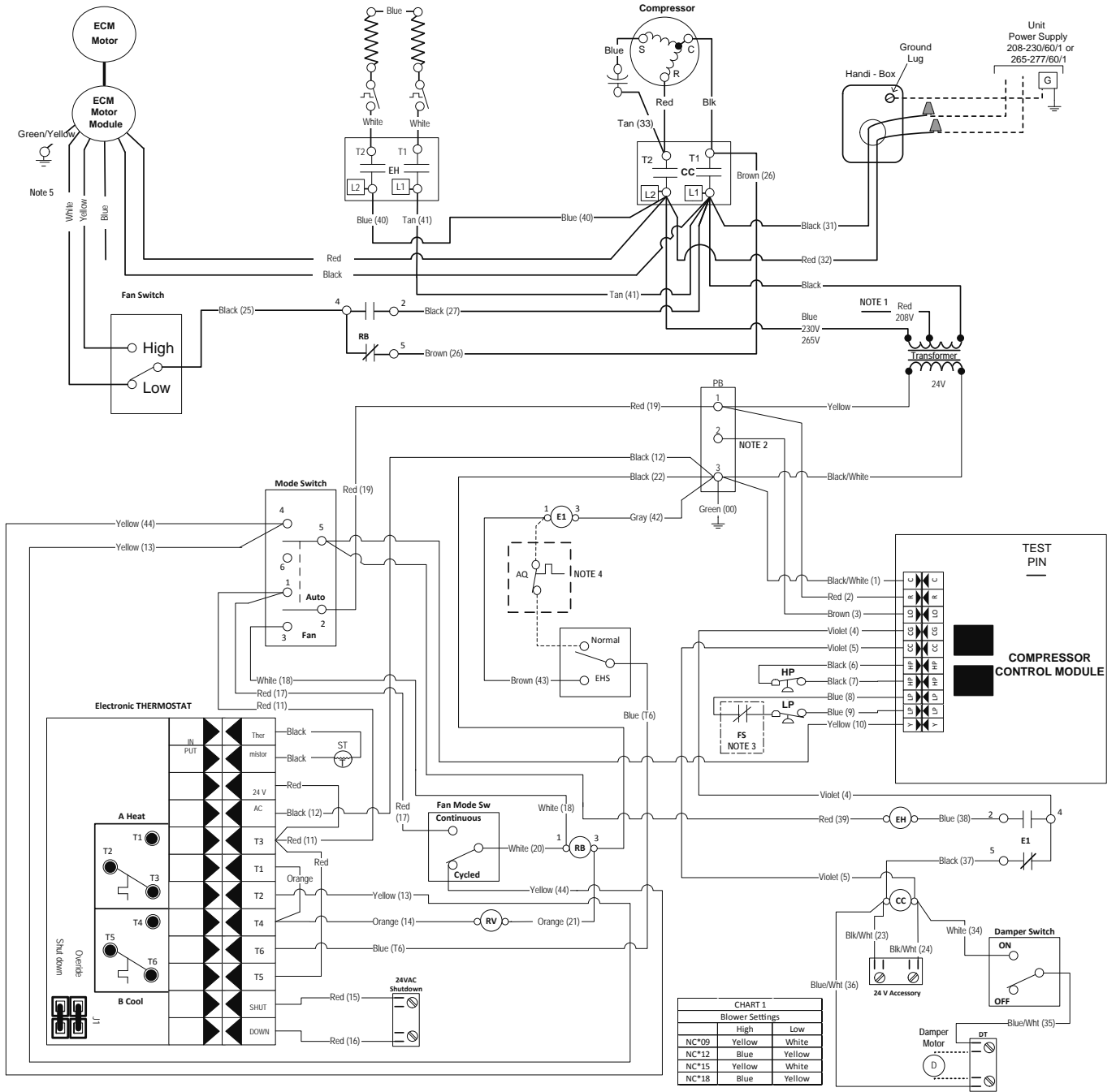

Legend

<p>— Factory low voltage wiring</p> <p>— Factory line voltage wiring</p> <p>- - - Field low voltage wiring</p> <p>- - - Field line voltage wiring</p> <p>○ Quick connect terminal</p> <p>▲ Wire nut</p>	<p>AQ - Aquastat</p> <p>CC - Compressor Contactor</p> <p>DT - Damper Terminal Block</p> <p>E1 - Electric Heat Relay</p> <p>EH - Electric Heat Contactor</p> <p>EHS - Electric Heat Switch</p> <p>FS - Freeze Sensing Device</p> <p>HP - High Pressure Switch</p> <p>LP - Low Pressure Switch</p> <p>PB - Power Block</p> <p>RB - Blower Relay</p> <p>RV - Reversing Valve Coil</p> <p>ST - Entering Air Temperature Sensor</p>	<p>L1 Field wire lug</p> <p>⊕ Earth Ground</p> <p>⎓ Relay Contacts - N.O., N.C.</p> <p>P Polarized connector</p>	<p>HP Switch - High Pressure</p> <p>LP Switch - Low Pressure</p> <p>○ Relay coil</p> <p>⊞ Capacitor</p> <p>⊕ Thermistor</p> <p>⊕ Temperature Switch</p>
---	--	--	---

Notes:

1. Switch Red and Blue wires for 208 volt operation
2. Terminal C of 24 V PB is used as "L" output for Brown wire 3 for Lockout.
3. Optional field installed freeze sensing device.
4. Optional field installed aquastat.
5. Factory wired. Refer to blower table settings.

Wiring Schematics cont.

ABC - ECM with Electric Heat and Remote Stat

208-230-265/60/1

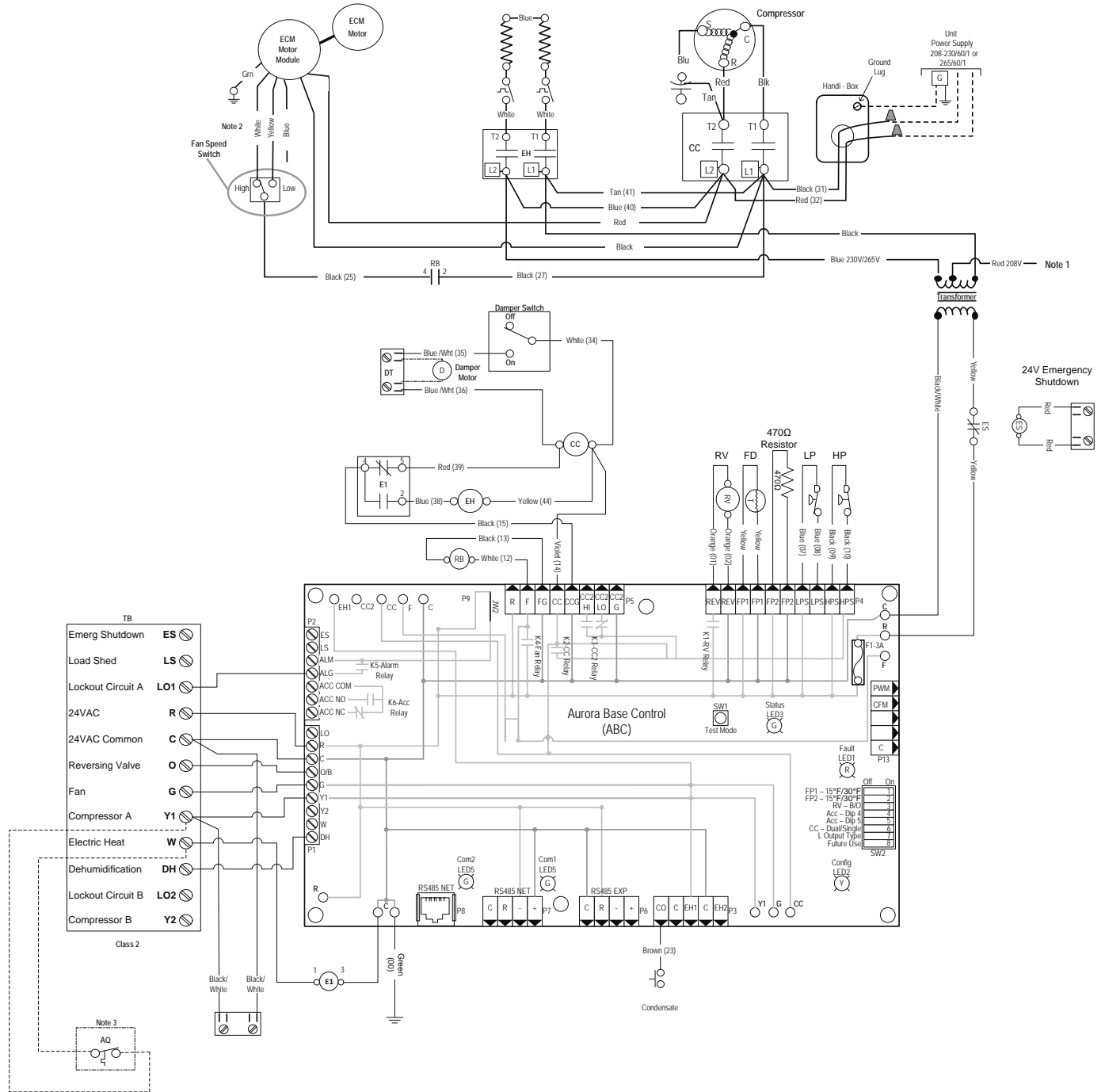

Wiring Schematics cont.

ABC - ECM with Electric Heat and Remote Stat

208-230-265/60/1

Notes:
 1 – Swap blue and red leads for 208V operation.
 2 – Factory wired. Refer to blower table settings.
 3 Optional field installed Aquastat for use with single heat.

Aurora Timing Events		
Event	Normal Mode	Test Mode
Random Start Delay	5 to 80 seconds	1 second
Compressor On Delay	5 seconds	< 1 second
Compressor Minimum On Time	2 minutes	5 seconds
Compressor Short Cycle Delay	4 minutes	15 seconds
Blower Off Delay	30 seconds	2 seconds
Fault Recognition Delay – High Pressure	Less than 1 second	Less than 1 second
Start-Up Bypass – Low Pressure	2 minutes	30 seconds
Fault Recognition Delay – Low Pressure	30 seconds	30 seconds
Start-Up Bypass – Low Water/Air Coil Limit	2 minutes	30 seconds
Fault Recognition Delay – Low Water/Air Coil Limit	30 seconds	30 seconds
Fault Recognition Delay – Condensate Overflow	30 seconds	30 seconds
Thermostat Call Recognition Time	2 seconds	2 seconds
Auxiliary Heat Staging Delay	5 minutes	20 seconds
Emergency Heat Staging Delay	2 minutes	7.5 seconds
Water Valve Slow Open Delay	90 seconds	90 seconds
Reheat Delay	30 seconds	30 seconds

Accessory Relay		
Operation	SW2-4	SW2-5
Cycle with Blower	On	On
Cycle with compressor	Off	Off
Water Valve Slow Open	On	Off
Outdoor Air Damper	Off	On

Aurora LED Flash Codes			
Slow Flash	1 second on and 1 second off		
Fast Flash	100 milliseconds on and 100 milliseconds off		
Flash Code	100 milliseconds on and 400 milliseconds off with a 2 second pause before repeating		
Random Start Delay			
Status LED (LED1, Green)	Fast Flash		
Configuration LED (LED2, Yellow)	Fast Flash		
Fault LED (LED3, Red)	Fast Flash		
Status LED (LED1, Green)	Configuration LED (LED2, Yellow)	Fault LED (LED3, Red)	
Normal Mode	ON	No Software Override	Flash ECM Setting
Control is Non-Functional	OFF	DIP Switch Override	Slow Flash
Test Mode	Slow Flash	ECM Configure Mode	Fast Flash
Lockout Active	Fast Flash	Reset Configure Mode	Off
Dehumidification Mode	Flash Code 2	Low Air Coil Limit Lockout - FP2	Flash Code 4
Reserved	Flash Code 3	Low Water Coil Limit Lockout - FP1	Flash Code 5
Reserved	Flash Code 4	Reserved	Flash Code 6
Load Shed	Flash Code 5	Condensate Overflow Lockout	Flash Code 7
ESD	Flash Code 6	Over/Under Voltage Shutdown	Flash Code 8
Reserved	Flash Code 7	Reserved	Flash Code 9
		Reserved	Flash Code 10
		Air/Water Coil Limit Sensor Error	Flash Code 11

CHART 1 Blower Settings		
	High	Low
NC*09	Yellow	White
NC*12	Blue	Yellow
NC*15	Yellow	White
NC*18	Blue	Yellow

Legend

<p>Factory Low Voltage Wiring</p> <p>Factory Line Voltage Wiring</p> <p>Field Line Voltage Wiring</p> <p>Optional Block</p> <p>DC Voltage PCB Traces</p> <p>Field Zone Sensor Wiring</p> <p>Internal Junction</p> <p>Quick Connect Terminal</p> <p>Field Wiring Lug</p> <p>Ground</p> <p>Relay Contacts - N.O., N.C.</p> <p>Capacitor</p> <p>Fuse</p> <p>Temperature Switch</p>	<p>Thermistor</p> <p>Relay Coil</p> <p>Switch - Condensate Overflow</p> <p>Switch - High pressure</p> <p>Switch - Low pressure</p> <p>Polarized connector</p> <p>Light Emitting Diode - Green</p> <p>Light Emitting Diode - Yellow</p> <p>Light Emitting Diode - Red</p> <p>Wire nut</p>
---	--

AO - Aquastat
 CC - Compressor Contactor
 CO - Condensate Overflow Sensor
 ES - Emergency Shutdown
 HP - High Pressure Switch
 LP - Low Pressure Switch
 FD - Freeze Detection Sensor
 F1 - Fuse

SW1 - Push button
 SW2 - DIP package 8 position
 PB - Power Block
 RB - Blower Relay
 RV - Reversing Valve Coil

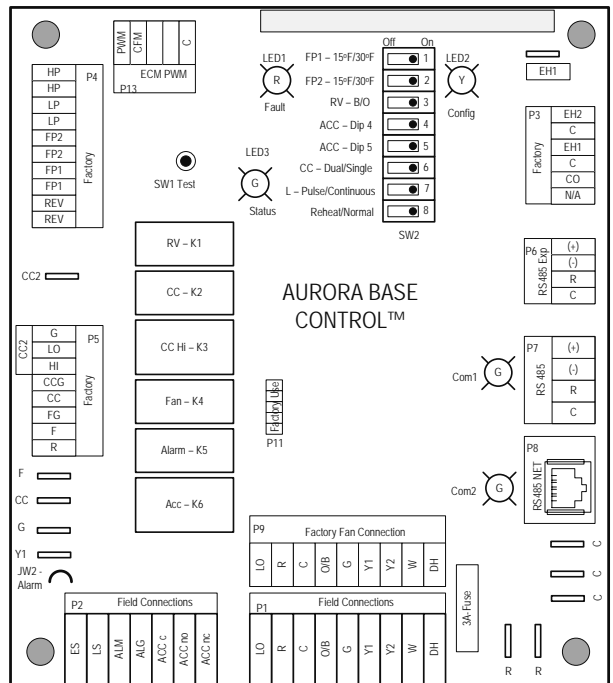

Wiring Schematics cont.

ABC - with ECM and Electronic Stat

208-230-265/60/1

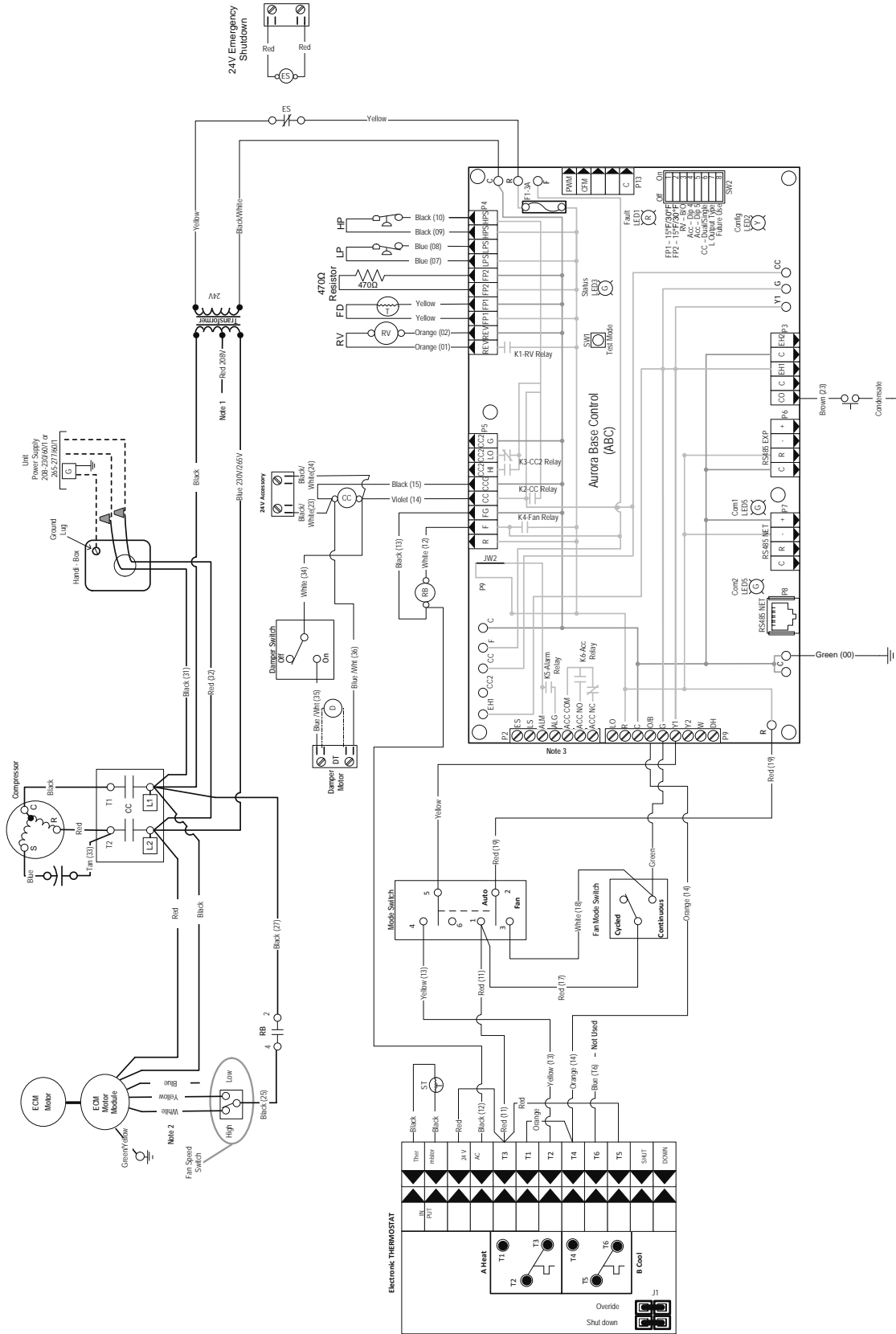

Wiring Schematics cont.

ABC - with ECM and Electronic Stat

208-230-265/60/1

Accessory Relay		
Operation	SW2-4	SW2-5
Cycle with Blower	On	On
Cycle with Compressor	Off	Off
Water Valve Slow Open	On	Off
Outdoor Air Damper	Off	On

Aurora Timing Events		
Event	Normal Mode	Test Mode
Random Start Delay	5 to 80 seconds	1 second
Compressor On Delay	5 seconds	< 1 second
Compressor Minimum On Time	2 minutes	5 seconds
Compressor Short Cycle Delay	4 minutes	15 seconds
Blower Off Delay	30 seconds	2 seconds
Fault Recognition Delay - High Pressure	Less than 1 second	Less than 1 second
Start-Up Bypass - Low Pressure	2 minutes	30 seconds
Fault Recognition Delay - Low Pressure	30 seconds	30 seconds
Start-Up Bypass - Low Water/Air Coil Limit	2 minutes	30 seconds
Fault Recognition Delay - Low Water/Air Coil Limit	30 seconds	30 seconds
Fault Recognition Delay - Condensate Overflow	30 seconds	30 seconds
Thermostat Call Recognition Time	2 seconds	2 seconds
Auxiliary Heat Staging Delay	5 minutes	20 seconds
Emergency Heat Staging Delay	2 minutes	7.5 seconds
Water Valve Slow Open Delay	90 seconds	90 seconds
Reheat Delay	30 seconds	30 seconds

Aurora LED Flash Codes					
Slow Flash	1 second on and 1 second off				
Fast Flash	100 milliseconds on and 100 milliseconds off				
Flash Code	100 milliseconds on and 400 milliseconds off with a 2 second pause before repeating				
Random Start Delay					
Status LED (LED1, Green)	Fast Flash				
Configuration LED (LED2, Yellow)	Fast Flash				
Fault LED (LED3, Red)	Fast Flash				
Status LED (LED1, Green)	Configuration LED (LED2, Yellow)	Fault LED (LED3, Red)			
Normal Mode	ON	No Software Override	Flash ECM Setting	Normal Mode	OFF
Control is Non-Functional	OFF	DIP Switch Override	Slow Flash	Input Fault Lockout	Flash Code 1
Test Mode	Slow Flash	ECM Configure Mode	Fast Flash	High Pressure Lockout	Flash Code 2
Lockout Active	Fast Flash	Reset Configure Mode	Off	Low Pressure Lockout	Flash Code 3
Dehumidification Mode	Flash Code 2			Low Air Coil Limit Lockout - FP2	Flash Code 4
Reserved	Flash Code 3			Low Water Coil Limit Lockout - FP1	Flash Code 5
Reserved	Flash Code 4			Reserved	Flash Code 6
Load Shed	Flash Code 5			Condensate Overflow Lockout	Flash Code 7
ESD	Flash Code 6			Over/Under Voltage Shutdown	Flash Code 8
Reserved	Flash Code 7			Reserved	Flash Code 9
				Reserved	Flash Code 10
				Air/Water Coil Limit Sensor Error	Flash Code 11

Legend

Factory Low Voltage Wiring
 Factory Line Voltage Wiring
 Field Low Voltage Wiring
 Field Line Voltage Wiring
 Optional Block
 DC Voltage PCB Traces
 Field Zone Sensor Wiring
 Internal Junction
 Quick Connect Terminal
 Field Wiring Lug
 Ground
 Relay Contacts - N.O., N.C.
 Capacitor
 Fuse
 Temperature Switch
 Thermistor
 Relay Coil
 Switch - Condensate Overflow
 Switch - High pressure
 Switch - Low pressure
 Polarized connector
 Light Emitting Diode - Green
 Light Emitting Diode - Yellow
 Light Emitting Diode - Red
 Wire nut
 CC - Compressor Contactor
 CO - Condensate Overflow Sensor
 ES - Emergency Shutdown
 HP - High Pressure Switch
 LP - Low Pressure Switch
 FD - Freeze Detection Sensor
 F1 - Fuse
 SW1 - Push button
 SW2 - DIP package 8 position
 PB - Power Block
 RB - Blower Relay
 RV - Reversing Valve Coil

Notes:

- 1 - Swap blue and red leads for 208V operation.
- 2 - Factory wired. Refer to blower table settings.
- 3 - Use ALG Output for 24V lockout.

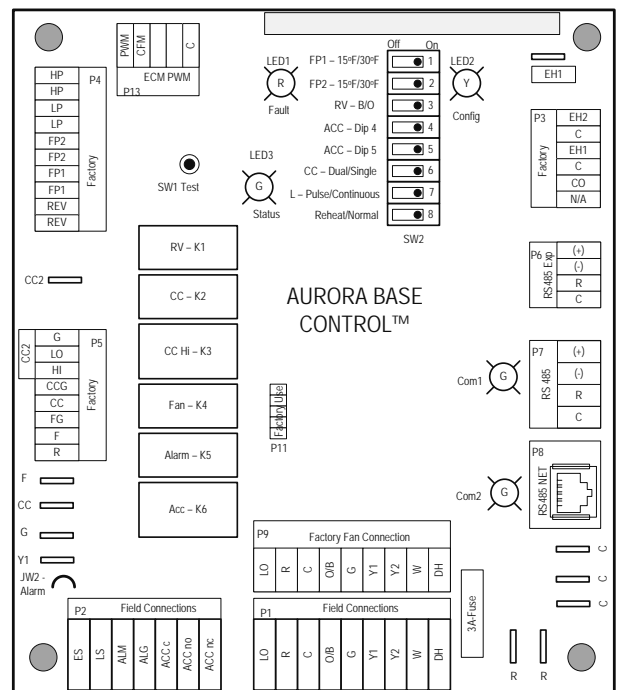

Controls

Control	General Description	Application	Display/Interface	Protocol	Thermostat Options
<p>CCM Control</p> 	<p>The CCM (Compressor control module) is a more reliable replacement for electro-mechanical control applications. It features a small microprocessor board that handles the lockout function of the unit. A second microprocessor handles the unit mounted thermostat for maintaining accurate room temperature.</p>	<p>Residential and commercial applications requiring minimal but reliable controls. Includes Random Start, High and low pressure switches and auto changeover capability.</p>	<p>Dial thermostat with Hi and Low fan speeds, and auto changeover or cont fan selection switches.</p>	<p>None</p>	<p>Unit Mounted Digital Dial Thermostat</p> <hr/> <p>Remote Mounted Standard Thermostat</p>

Standard CCM Control Features

Compressor control module (CCM) controls are standard on the Aston Series console heat pump. This control features unit mounted thermostat and switches,

Features of the standard control are:

- Easy to understand color coded thermostat adjustment markings.
- Large, rocker type mode and fan switches.
- Internally mounted fan switch to choose cycled or constant fan operation.
- High pressure and low pressure safety controls to protect the unit components.
- Lockout circuit to shut down unit operation upon receipt of a fault indicator from the safety controls.
- A 24 volt control circuit allows for safe and easy diagnosis.

The user selects either “Heat/Cool” or “Fan Only” on the mode switch, then either “High” or “Low” at the fan speed switch. The temperature can be controlled by rotating the thermostat control knob.

Figure 6: Unit Mounted Control

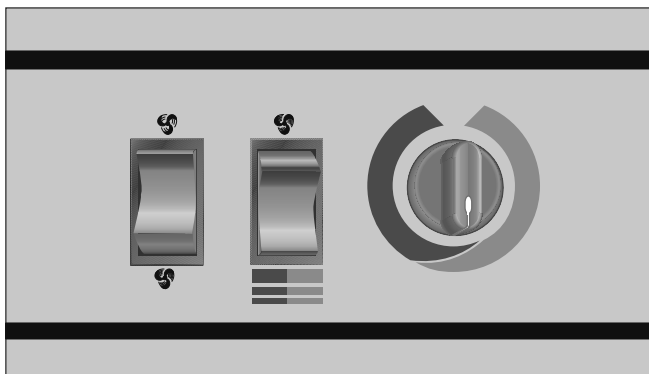

The “Fan Only” setting provides constant fan operation.

In the “Heat” mode, a call for heat by the thermostat closes the compressor contactor contacts, energizing the compressor, which will run until the thermostat is satisfied.

In the “Cool” mode, a call for cooling by the thermostat energizes the reversing valve and closes the compressor contactor contacts, energizing the compressor, which will run until the thermostat is satisfied.

The emergency electric heat operation in the “Heat/Cool” mode is subject to the setting of the internally mounted mode switch. The optional, factory installed electric heat will operate when the internally mounted mode switch is in the “Emergency Heat” mode. In the “Heat” mode, a call for heating energizes the fan and electric heater contactor, energizing the electric heat elements and fan, which will run until the thermostat is satisfied. When the internally mounted mode switch is in the “Normal/Boilerless” mode the unit operates in its normal “Heat/Cool” operation, unless there is an aquastat controller. When the normally open circuit of the aquastat closes and the unit is in the heating mode, it will switch to the “Emergency Heat” condition until the thermostat is satisfied or the aquastat opens restarting the compressor.

If either the low or high pressure safety switches are opened, the compressor and reversing valve are disabled by the lockout relay. Unit operation will resume only after the voltage to the unit is interrupted or the mode switch is placed in the “Off” position.

If the electric heat limit switches are opened, the electric heat is disabled.

Controls cont.

Aurora ‘Base’ Control



NOTE: Refer to the Aurora Base Control Application and Troubleshooting Guide and the Instruction Guide: Aurora Interface and Diagnostics (AID) Tool for additional information.

Control Features

Software ABC Standard Version 3.0

Single or Dual Capacity Compressors

Either single or dual capacity compressors can be operated.

Variable Speed ECM

Blower Motor Option (If Applicable)

A Variable Speed ECM blower motor can be driven directly using the onboard PWM output. Four blower speeds are available based upon the G, Y1, Y2, and W input signals to the board. The blower speeds can be changed either by the ECM manual configurations mode method or by using the Aurora AID Tool directly. All four blower speeds can be set to the same speed if desired.

5-Speed ECM Blower Motor Option (If Applicable)

A 5-Speed ECM blower motor will be driven directly using the thermostat connections. Any of the G, Y1, or Y2/W signals can drive any of the 5 available pre-programmed blower speeds on the motor. All 5 Series "G" vintage units will be wired this way at the factory.

Other Control Features

- Random start at power up
- Anti-short cycle protection
- High and low pressure cutouts
- Loss of charge
- Water coil freeze detection
- Air coil freeze detection
- Over/under voltage protection
- Condensate overflow sensor
- Load shed
- Dehumidification (where applicable)
- Emergency shutdown
- Hot gas reheat operation (where applicable)
- Diagnostic LED
- Test mode push button switch
- Two auxiliary electric heat outputs
- Alarm output
- Accessory output with N.O. and N.C.
- Modbus communication (master)
- Modbus communication (slave)

Field Selectable Options via Hardware

DIP Switch (SW1) - Test/Configuration Button (See SW1 Operation Table)

Test Mode

The control is placed in the test mode by holding the push button switch SW1 for 2 - 5 seconds. In test mode most of the control timings will be shortened by a factor of sixteen (16). LED3 (green) will flash at 1 second on and 1 second off. Additionally, when entering test mode LED1 (red) will flash the last lockout one time. Test mode will automatically time out after 30 minutes. Test mode can be exited by pressing and holding the SW1 button for 2 to 5 seconds or by cycling the power. **NOTE:** Test mode will automatically be exited after 30 minutes.

Variable Speed ECM Configuration Mode (If Applicable)

The control is placed in the ECM configuration mode by holding the pushbutton switch SW1 for 5 to 10 seconds, the high, low, and "G" ECM speeds can be selected by following the LED display lights. LED2 (yellow) will fast flash when entering the ECM configuration. When setting "G" speed LED3 (green) will be continuously lit, for low speed LED1 (red) will be continuously lit, and for high speed both LED3 (green) and LED1 (red) will be continuously lit. During the ECM configuration mode LED2 (yellow) will flash each of the 12 possible blower speeds 3 times. When the desired speed is flashed press SW1, LED2 will fast flash until SW1 is released. "G" speed has now been selected. Next select low speed, and high speed blower selections following the same process above. After third selection has been made, the control will exit the ECM configuration mode. Aux fan speed will remain at default or current setting and requires the AID Tool for adjustment.

Reset Configuration Mode

The control is placed in reset configuration mode by holding the push button switch SW1 for 50 to 60 seconds. This will reset all configuration settings and the EEPROM back to the factory default settings. LED3 (green) will turn off when entering reset configuration mode. Once LED3 (green) turns off, release SW1 and the control will reset.

DIP Switch (SW2)

- SW2-1** FP1 Selection - Low water coil temperature limit setting for freeze detection. On = 30°F; Off = 15°F.
- SW2-2** FP2 Selection - On = 30°F; Off = N/A
- SW2-3** RV - O/B - thermostat type. Heat pump thermostats with "O" output in cooling or "B" output in Heating can be selected. On = O; Off = B.
- SW2-4** Access Relay Operation (P2)
- and 2-5**

Access Relay Operation	SW2-4	SW2-5
Cycle with Blower	ON	ON
Cycle with Compressor	OFF	OFF
Water Valve Slow Opening	ON	OFF
Cycle with Comm. T-stat Hum Cmd	OFF	ON

Controls cont.

Cycle with Blower - The accessory relay will cycle with the blower output.

Cycle with Compressor - The accessory relay will cycle with the compressor output.

Water Valve Slow Opening - The accessory relay will cycle and delay both the blower and compressor output for 90 seconds.

SW2-6 CC Operation - selection of single or dual capacity compressor. On = Single Stage; Off = Dual Capacity

SW2-7 Lockout and Alarm Outputs (P2) - selection of a continuous or pulsed output for both the LO and ALM Outputs. On = Continuous; Off = Pulsed

SW2-8 Future Use

Alarm Jumper Clip Selection

From the factory, ALM is connected to 24 VAC via JW2. By cutting JW2, ALM becomes a dry contact connected to ALG.

Variable Speed ECM Blower Speeds

The blower speeds can be changed either by using the ECM manual configurations mode method or by using the Aurora AID Tool directly (see Instruction Guide: Aurora Interface and Diagnostics (AID) Tool topic).

Field Selectable Options via Software

(Selectable via the Aurora AID Tool)

ECM Blower Speeds

An ECM blower motor can be driven directly using the onboard PWM output. Four blower speeds are available, based upon the "G", Y1 (low), Y2 (high), and Aux input signals to the board. The blower speeds can be changed either by the ECM manual configurations mode method (see ECM Configuration Mode topic) or by using the Aurora AID Tool directly. All four blower speeds can be set to the same speed if desired. Aux blower speed will remain at default or current setting and requires the AID Tool for adjustment.

Safety Features

The following safety features are provided to protect the compressor, heat exchangers, wiring and other components from damage caused by operation outside of design conditions.

Fuse - a 3 amp automotive type plug-in fuse provides protection against short circuit or overload conditions.

Anti-Short Cycle Protection - 4 minute anti-short cycle protection for the compressor.

Random Start - 5 to 80 second random start upon power up.

Fault Retry - in the fault condition, the control will stage off the outputs and then "try again" to satisfy the thermostat Y input call. Once the thermostat input calls are satisfied, the control will continue on as if no fault occurred. If 3 consecutive faults occur without satisfying the thermostat Y input call, then the control will go to Lockout mode.

Lockout - when locked out, the blower will operate continuously in "G" speed, and PSC blower motor output will remain on. The Alarm output (ALM) and Lockout output (L) will be turned on. The fault type identification display LED1 (Red) shall flash the fault code. To reset lockout conditions with SW2-8 On, thermostat inputs "Y1", "Y2", and "W" must be removed for at least 3 seconds. To reset lockout conditions with SW2-8 Off, thermostat inputs "Y1", "Y2", "W", and "DH" must be removed for at least 3 seconds. Lockout may also be reset by turning power off for at least 30 seconds or by enabling the emergency shutdown input for at least 3 seconds.

Lockout With Emergency Heat - if the control is locked out in the heating mode, and a Y2 or W input is received, the control will operate in the emergency heat mode while the compressor is locked out. The first emergency heat output will be energized 10 seconds after the W input is received, and the blower will shift to high speed. If the control remains locked out, and the W input is present, additional stage of emergency heat will stage on after 2 minutes. When the W input is removed, all of the emergency heat outputs will turn off, and the ECM blower will shift to "G" speed and PSC blower motor output will remain on.

High Pressure - fault is recognized when the Normally Closed High Pressure Switch, P4-9/10 opens, no matter how momentarily. The High Pressure Switch is electrically in series with the Compressor Contactor and serves as a hard-wired limit switch if an overpressure condition should occur.

Low Pressure - fault is recognized when the Normally Closed Low Pressure Switch, P4-7/8 is continuously open for 30 seconds. Closure of the LPS any time during the 30 second recognition time restarts the 30 second continuous open requirement. A continuously open LPS shall not be recognized during the 2 minute startup bypass time.

Loss of Charge - fault is recognized when the Normally Closed Low Pressure Switch, P4-7/8 is open prior to the compressor starting.

Condensate Overflow - fault is recognized when the impedance between this line and 24 VAC common or chassis ground drops below 100K ohms for 30 seconds continuously.

Freeze Detection (Coax) - set points shall be either 30°F or 15°F. When the thermistor temperature drops below the selected set point, the control shall begin counting down the 30 seconds delay. If the thermistor value rises above the selected set point, then the count should reset. The resistance value must remain below the selected set point for the entire length of the appropriate delay to be recognized as a fault. This fault will be ignored for the initial 2 minutes of the compressor run time.

Freeze Detection (Air Coil) - uses the FP2 input to protect against ice formation on the air coil. The FP2 input will operate exactly like FP1 except that the set point is 30 degrees and is not field adjustable.

Controls cont.

Over/Under Voltage Shutdown - An over/under voltage condition exists when the control voltage is outside the range of 18 VAC to 30 VAC. If the over/under voltage shutdown lasts for 15 minutes, the lockout and alarm relay will be energized. Over/under voltage shutdown is self-resetting in that if the voltage comes back within range of 18 VAC to 30 VAC for at least 0.5 seconds, then normal operation is restored.

Operation Description

Power Up - The unit will not operate until all the inputs and safety controls are checked for normal conditions. The unit has a 5 to 80 second random start delay at power up. Then the compressor has a 4 minute anti-short cycle delay after the random start delay.

Standby In standby mode, Y1, Y2, W, DH, and G are not active. Input O may be active. The blower and compressor will be off.

Heating Operation

Single Compressor Heating, 2nd Stage (Y1, Y2)

The compressor will be staged to full capacity 20 seconds after Y2 input is received. The ECM blower will shift to high speed seconds after the Y2 input is received.

Dual Compressor Heating, 2nd Stage (Y1, Y2)

In dual compressor operation, two ABC boards used in 24 VAC operation, there will be a Y2 call to the Y1 input on the second ABC. The compressor will stage to full capacity 30 seconds after Y1 input is received to the second board.

Single Compressor Heating, 3rd Stage (Y1, Y2, W)

The hot water pump is de-energized and the first stage of electric heat is energized 10 seconds after the W command is received. If the demand continues the second stage of electric heat will be energized after 5 minutes.

Dual Compressor Heating, 3rd Stage (Y1, Y2, W)

The first stage of electric heat is energized 10 seconds after the W command is received. If the demand continues the second stage of electric heat will be energized after 5 minutes

Emergency Heat (W) - The blower will be started on "G" speed, 10 seconds later the first stage of electric heat will be turned on. 5 seconds after the first stage of electric heat is energized the blower will shift to Aux speed. If the emergency heat demand is not satisfied after 2 minutes the second electric heat stage will be energized.

Blower (G) - The blower will start immediately upon receiving a thermostat G command. If there are no other commands from the thermostat the ECM will run on "G" speed until the G command is removed. Regardless of blower input (G) from the thermostat, the blower will remain on for 30 seconds at the end of each heating cycle.

Cooling Operation

In all cooling operations, the reversing valve directly tracks the O input. Thus, anytime the O input is present, the reversing valve will be energized.

Single Compressor Cooling, 2nd Stage (Y1, Y2, O)

The compressor will be staged to full capacity 20 seconds after Y2 input was received. The ECM blower will shift to high speed 15 seconds after the Y2 input was received.

Dual Compressor Cooling, 2nd Stage (Y1, Y2, O)

In dual compressor operation, two ABC boards used in 24 VAC operation, there will be a Y2 call to the Y1 input on the second ABC. The compressor will stage to full capacity 30 seconds after Y1 input is received to the second board.

Blower (G) - The blower will start immediately upon receiving a thermostat G command. If there are no other commands from the thermostat the ECM will run on "G" speed until the G command is removed. Regardless of blower input (G) from the thermostat, the blower will remain on for 30 seconds at the end of each heating, cooling, and emergency heat cycle.

Dehumidification (Y1, O, DH or Y1, Y2, O, DH) - When a DH command is received from the thermostat during a compressor call for cooling the ECM blower speed will be reduced by 15% to increase dehumidification.

Emergency Shutdown - Four (4) seconds after a valid ES input, P2-7 is present, all control outputs will be turned off and remain off until the emergency shutdown input is no longer present. The first time that the compressor is started after the control exits the emergency shutdown mode, there will be an anti-short cycle delay followed by a random start delay. Input must be tied to common to activate.

Continuous Blower Operation - The blower output will be energized any time the control has a G input present, unless the control has an emergency shutdown input present. The blower output will be turned off when G input is removed.

Load Shed - The LS input disables all outputs with the exception of the blower output. When the LS input has been cleared, the anti-short cycle timer and random start timer will be initiated. Input must be tied to common to activate.

Controls cont.

Aurora ‘Base’ Control LED Displays

These three LEDs display the status, configuration, and fault codes for the control. These can also be read in plain English via the Aurora AID Tool.

Status LED (LED3, Green)

Description of Operation	Fault LED, Green
Normal Mode	ON
Control is Non-functional	OFF
Test Mode	Slow Flash
Lockout Active	Fast Flash
Dehumidification Mode	Flash Code 2
(Future Use)	Flash Code 3
(Future Use)	Flash Code 4
Load Shed	Flash Code 5
ESD	Flash Code 6
(Future Use)	Flash Code 7

Configuration LED (LED2, Yellow)

Description of Operation	Configuration LED, Yellow
No Software Overwritten	Flashing ECM Setting
DIP Switch was Overwritten	Slow Flash
ECM Configuration Mode	Fast Flash

Fault LED (LED1, Red)

Red Fault LED		LED Flash Code*	Lockout	Reset/Remove
ABC Basic Faults	Normal - No Faults	OFF	-	
	Fault - Input	1	No	Auto
	Fault - High Pressure	2	Yes	Hard or Soft
	Fault - Low Pressure	3	Yes	Hard or Soft
	Fault - Freeze Detection FP2	4	Yes	Hard or Soft
	Fault - Freeze Detection FP1	5	Yes	Hard or Soft
	Fault - Condensate Overflow	7	Yes	Hard or Soft
	Fault - Over/Under Voltage	8	No	Auto
	Fault - FP1 & FP2 Sensor Error	11	Yes	Hard or Soft

NOTE: All codes >11 use long flash for tens digit and short flash for the ones digit. 20, 30, 40, 50, etc. are skipped.

Aurora Interface and Diagnostics (AID) Tool

The Aurora Interface and Diagnostics (AID) Tool is a device that is a member of the Aurora network. The AID Tool is used to troubleshoot equipment which uses the Aurora control via Modbus RTU communication. The AID Tool provides diagnostics, fault management, ECM



setup, and system configuration capabilities to the Aurora family of controls. An AID Tool is recommended, although not required, for ECM airflow settings. The AID Tool simply plugs into the exterior of the cabinet in the AID Tool port.

ABC Control Board Layout

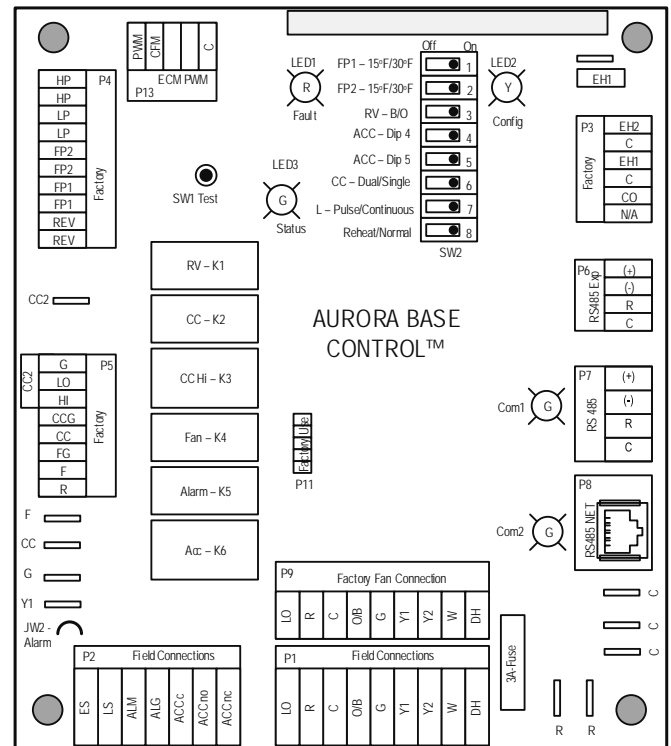

Controls cont.

Aurora ‘Advanced’ Control Features

The Aurora ‘Advanced’ Control system expands on the capability of the Aurora ‘Base’ Control (ABC) by adding the Aurora Expansion Board (AXB). All of the preceding features of the Aurora ‘Base’ Control are included. The following control description is of the additional features and capability of the Aurora advanced control.

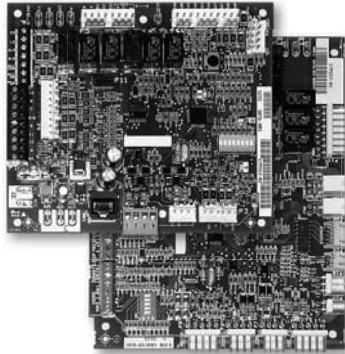

It is highly recommended the installing/servicing contractor obtain an Aurora Interface and Diagnostic Tool (AID) and specialized training before attempting to install or service an Aurora ‘Advanced’ control system.



The additional AXB features include the following:

AXB DIP Switch

DIP 1 - ID: This is the AXB ModBus ID and should always read On.

DIP 2 & 3 - Future Use

DIP 4 & 5 - Accessory Relay2: A second, DIP configurable, accessory relay is provided that can be cycled with the compressor 1 or 2, blower, or the Dehumidifier (DH) input. This is to complement the Accessory 1 Relay on the ABC board.

Position	DIP 4	DIP 5	Description
1	ON	ON	Cycles with Fan or ECM (or G)
2	OFF	ON	Cycles with CC1 first stage of compressor or compressor spd 6
3	ON	OFF	Cycles with CC2 second stage of compressor or compressor spd 7-12
4	OFF	OFF	Cycles with DH input from ABC board

Advanced Hot Water Generator Control (Domestic Hot Water Option)

In lieu of the ‘Base Hot Water Generator Control’, the Advanced features an AID Tool selectable temperature limit and microprocessor control of the process. This will maximize hot water generation and prevent undesirable energy use. An alert will occur when the hot water input temperature is at or above setpoint (100°F - 140°F) for 30 continuous seconds (130°F is the default setting). This alert will appear as an E15 on the AID Tool and the hot water pump de-energizes. Hot water pump operations resume on the next compressor cycle or after 15 minutes of continuous compressor operation during

the current thermostat demand cycle. Since compressor hot gas temperature is dependent on loop temperature in cooling mode, loop temperatures may be too low to allow proper heating of water. The control will monitor water and refrigerant temperatures to determine if conditions are satisfactory for heating water. LED1 (red LED) will flash code 15 when the DHW limit is reached and when conditions are not favorable for water heating. Error code 15 will also be displayed on the AID Tool in the fault screen. This flash code is a noncritical alert and does not necessarily indicate a problem.

Compressor Monitoring

The AXB includes two current transducers to monitor the compressor current and starting characteristics. Open circuits or welded contactor faults will be detected. A fault will produce an E10 code.

IntelliZone2 Zoning Compatibility (Optional IntelliZone2 Zoning)

A dedicated input to connect and communicate with the IntelliZone2 (IZ2) zoning system is provided on P7. There is a dedicated communication port using a proprietary ModBus protocol. An AXB can be added to other selected ABC-only systems as well. Then an advanced communicating IntelliZone2 zoning system can be added to ABC-only systems. Consult the IntelliZone2 literature for more information.

Variable Speed Pump

This input and output are provided to drive and monitor a variable speed pump. The VS pump output is a PWM signal to drive the variable speed pump. The minimum and maximum level are set using the AID Tool. 75% and 100% are the default settings respectively. The VS data input allows a separate PWM signal to return from the pump giving fault and performance information. Fault received from the variable speed pump will be displayed as E16.

Modulating Water Valve

This output is provided to drive a modulating water valve. Through advanced design the 0-10VDC valve can be driven directly from the VS pump output. The minimum and maximum level are set in the same way as the VS pump using the AID Tool. 75% and 100% are the default settings respectively.

Loop Pump Linking

This input and output are provided so that two units can be linked together with a common flow center. When either unit has a call for loop pump, both unit’s loop pump relays and variable speed pumps are energized. The flow center then can simply be wired to either unit. The output from one unit should be routed to the input of the other. If daisy chained up to 16 heat pumps can be wired and linked together in this fashion.

Controls cont.

Advanced Communication Ports

Communication ports P6 and P8 will provide future expansion via dedicated protocols. These are for future use.

Smart Grid-On Peak (SG) Input

The 'On Peak' input was designed to allow utilities to utilize simple radio controlled switches to control the On Electric Peak behavior of the 5 and 7 Series Geothermal Heat Pumps. With a closed contact signal, this input will limit the operation and thus the power consumption of the unit by one of the below selections. The AID Tool will allow configuration of this input for the action of:

- No Action
- Disable compressor operation until removed
- Go to On Peak thermostat settings until removed [Requires Com T-Stat] (Future Release)
- Compressor limited to 50% or low cap until removed [dual capacity or variable speed only] (Future Release)
- Disable compressor operation for 1/2 hr (can be removed immediately) (Future Release)

Then Flash Code 7 on the Green LED for the 'On Peak' mode. And On Peak will display on communicating thermostats.

Home Automation 1 and 2 Inputs

The Home automation inputs are simple closed contact inputs that will trigger an AID Tool and thermostat alert for the homeowner. These would require optional sensors and or equipment for connection to the AXB board. With two inputs two different sensors can be selected. The selected text will then be displayed on the AID Tool and communicating thermostats. These events will NOT alter functionality or operation of the heat pump/accessories and is for homeowner/service notification only.

Home Automation 1 - E23 HA1

With a closed dry contact signal, this input will cause an alarm and Alert Code 23 to indicate on the stat or flash on ABC. The AID Tool will allow configuration of this input between the following selections:

- No Action
- Home Automation Fault [no lockout info only]
 - Output from home automation system
- Security Alarm [no lockout info only]
 - Output from home security
- Sump Alarm Fault [no lockout info only]
 - Switch output from sump sensor
- Smoke/CO Alarm Fault [no lockout info only]
 - Switch output from Smoke/CO sensor
- Dirty Filter Alarm [no lockout info only]
 - Output from dirty filter sensor

Home Automation 2 - E24 HA2

With a closed dry contact signal, this input will cause an alarm and Alert Code 24 to indicate on the stat or flash on ABC. The AID Tool will allow configuration of this input between the following selections:

- No Action
- Home Automation Fault [no lockout info only]
 - Output from home automation system
- Security Alarm [no lockout info only]
 - Output from home security
- Sump Alarm Fault [no lockout info only]
 - Switch output from sump sensor
- Smoke/CO Alarm Fault [no lockout info only]
 - Switch output from Smoke/CO sensor
- Dirty Filter Alarm [no lockout info only]
 - Output from dirty filter sensor

Monitoring Sensor Kits

Energy Monitoring

(Standard Sensor Kit on 'Advanced' models)

The Energy Monitoring Kit includes two current transducers (blower and electric heat) added to the existing two compressor sensors so that the complete power usage of the heat pump can be measured. The AID Tool provides configuration detail for the type of blower motor and a line voltage calibration procedure to improve the accuracy. This information can be displayed on the AID Tool or selected communicating thermostats. The TPCM32U03/04 will display instantaneous energy use while the color touchscreen TPCC32U01 will in addition display a 13 month history in graph form.

Refrigerant Monitoring (optional sensor kit)

The optional Refrigerant Monitoring Kit includes two pressure transducers, and three temperature sensors, heating liquid line, suction temperature and existing cooling liquid line (FP1). These sensors allow the measurement of discharge and suction pressures, suction and liquid line temperatures as well as superheat and subcooling. This information will only be displayed on the AID Tool.

Performance Monitoring (optional sensor kit)

The optional Performance Monitoring Kit includes three temperature sensors, entering and leaving water, leaving air temperature and a water flow rate sensor. With this kit heat of extraction and rejection will be calculated. This requires configuration using the AID Tool for selection of water or antifreeze.

Controls cont.

Special Modes and Applications

5-Speed ECM Blower Motor

Normally the 5-Speed ECM motor can be driven off of thermostat signals and the ABC connector P9.

Communicating thermostats, however present a special problem in this application since they operate without 24 VAC thermostat signals. The ABC board is wired to operate these systems from the alternate relay output signals CC1, CC2, Fan, and EH1 and should be wired for this.

Communicating Digital Thermostats

The Aurora controls system also features either mono-chromatic or color touch screen graphic display thermostats for user interface. These displays not only feature easy to use graphical interface but display alerts and faults in plain English. Many of the features discussed here may not be applicable without these thermostats.

Dehumidification - Passive

In passive dehumidification mode, the airflow is reduced by 15% from the heating airflow setting. If cooling airflow is set to +5, -5 or -10% of heating airflow it will automatically be set to -15% of heating airflow whenever the dehumidification call is present in the communicating stat or from the thermostat input DH. If the airflow for cooling is already set to -15% no airflow change will be noticed from normal cooling. Dehumidification mode will be shown on the ABC and the communicating thermostats.

Aurora ‘Advanced’ Control LED Displays

These three LEDs display the status, configuration, and fault codes for the control. These can also be read in plain English via the Aurora AID Tool.

Status LED (LED3, Green)

Description of Operation	Fault LED, Green
Normal Mode	ON
Control is Non-functional	OFF
Test Mode	Slow Flash
Lockout Active	Fast Flash
Dehumidification Mode	Flash Code 2
Load Shed	Flash Code 5
Emergency Shutdown	Flash Code 6
On Peak Mode	Flash Code 7
(Future Use)	Flash Code 8
(Future Use)	Flash Code 9

Configuration LED (LED2, Yellow)

Description of Operation	Configuration LED, Yellow
No Software Overwritten	ECM Setting
DIP Switch Overwritten	Slow Flash
ECM Configuration Mode	Fast Flash
Reset Configuration Mode	OFF

Fault LED (LED1, Red)

Red Fault LED	LED Flash Code *	Lockout	Reset/Remove	Fault Condition Summary	
Normal - No Faults	Off	-			
ABC Basic Faults	Fault-Input	1	No	Auto	Tstat input error. Autoreset upon condition removal.
	Fault-High Pressure	2	Yes	Hard or Soft	HP switch has tripped (>600 psi)
	Fault-Low Pressure	3	Yes	Hard or Soft	Low Pressure Switch has tripped (<40 psi for 30 continuous sec.)
	Fault-Freeze Detection FP2	4	Yes	Hard or Soft	Freeze protection sensor has tripped (<15 or 30 degF for 30 continuous sec.)
	Fault-Freeze Detection FP1	5	Yes	Hard or Soft	Freeze protection sensor has tripped (<15 or 30 degF for 30 continuous sec.)
	Fault-Condensate Overflow	7	Yes	Hard or Soft	Condensate switch has shown continuity for 30 continuous sec.
	Fault-Over/Under Voltage	8	No	Auto	Instantaneous voltage is out of range. **Controls shut down until resolved.
	Fault-FP1 Snsr Error	11	Yes	Hard or Soft	If FP1 Sensor Error
ABC & AXB Advanced Faults	Fault-Compressor Monitor	10	Yes	Hard or Soft	Open Crkt, Run, Start or welded cont
	Non-CriticAXBSnsrErr	13	No	Auto	Any Other Sensor Error
	CriticAXBSnsrErr	14	Yes	Hard or Soft	Sensor Error for EEV or HW
	Alert-HotWtr	15	No	Auto	HW over limit or logic lockout. HW pump deactivated.
	Fault-VarSpdPump	16	No	Auto	Alert is read from PWM feedback.
	Not Used	17	No	Auto	I22 Com Fault. Autoreset upon condition removal.
	Non-CritComErr	18	No	Auto	Any non-critical com error
	Fault-CritComErr	19	No	Auto	Any critical com error. Auto reset upon condition removal
	Alarm - Low Loop Pressure	21	No	Auto	Loop pressure is below 3 psi for more than 3 minutes
	Alarm - Home Automation 1	23	No	Auto	Closed contact input is present on Dig 2 input - Text is configurable
Alarm - Home Automation 2	24	No	Auto	Closed contact input is present on Dig 3 input - Text is configurable	

NOTES:

*All codes >11 use long flash for tens digit and short flash for the ones digit. 20, 30, 40, 50 etc. are skipped!
Alert' is a noncritical sensor or function that has failed. Normal operation of the heat pump is maintained but service is desired at some point.

Startup Notes

Emergency Electric Resistance Heat

A factory-installed emergency electric heater package is available. Rated for 2,000 watts on models GC09 through GC12 and 3,000 watts on models GC15 through GC18. The heater package consists of ni-cad elements, ceramic insulators, and thermal limit switches. A concealed, chassis mounted rocker switch controls the heater mode operation and allows the field installation of an aquastat for boilerless unit operation.

Electrical Disconnect

Field installed on the optional chassis back plate, the console disconnect provides a permanent electrical connection to the main electrical supply branch. Wiring between the disconnect and the unit chassis is field supplied and allows the electrical power source to the chassis to be interrupted for unit servicing.

Non-Fused

Constructed of heavy gauge galvanized steel, the rocker style disconnect switch provides reliable electrical control. Wiring pigtailed, using 12-gauge wires, are factory installed to simplify field wiring.

Fused

Similar in construction to the non-fused electrical disconnect. The fused disconnect is available in five models with equipment rated fuses to provide additional circuit protection. The fuses are panel mounted to allow easy inspection and removal without removing the cover on the disconnect.

- CFD-10 - 10 amp rated fuse
- CFD-12 - 12 amp rated fuse
- CFD-15 - 15 amp rated fuse
- CFD-20 - 20 amp rated fuse
- CFD-25 - 25 amp rated fuse

Motorized Outside Air Damper

A field installed motorized outside air damper is available to allow the introduction of fresh air into the conditioned space through an outside vent. The damper motor is powered by 24 volts with a spring-close design in the event of a power failure. The damper blade and housing are constructed of aluminum for corrosion resistance and the blade includes a neoprene gasket to prevent air infiltration during off cycles. The damper assembly is installed on the optional chassis back plate and a two-wire low voltage connection simplifies wiring. A concealed, chassis mounted rocker switch allows the damper to be disabled.

Hydronic Loop Controller for Boiler/Tower Installations

The hydronic loop controller is a microprocessor based control panel for control of water loop heat rejector (tower), heat supplier (boiler), and/or water well pumps and circulation pumps. Includes audible and visual alarms, temperature indication, and add-on options of low switches, remote alarm sensor wells and pump alternator.

Startup Checklist / Unit Startup Steps

Before Powering Unit, Check The Following:

- High voltage is correct and matches nameplate.
 - Fuses, breakers and wire size correct.
 - Low voltage wiring complete.
 - Piping completed and water system cleaned and flushed.
 - Air is purged from closed loop system.
 - Isolation valves are open, water control valves or loop pumps wired.
 - Condensate line open and correctly pitched.
 - Transformer switched to 208V if applicable.
 - Dip switches are set correctly, if applicable.
 - Blower rotates freely
 - Air filter is clean and in position.
 - Service/access panels are in place.
 - Return air temperature is between 50-80°F heating and 60-95°F cooling.
1. Check air coil cleanliness to insure optimum performance. Clean as needed according to maintenance guidelines. To obtain maximum performance the air coil should be cleaned before startup. A 10-percent solution of dishwasher detergent and water is recommended for both sides of coil, a thorough water rinse should follow.

Startup Steps

Note: Complete the Equipment Start-Up/Commissioning Check Sheet during this procedure. Refer to thermostat operating instructions and complete the startup procedure.

1. Initiate a control signal to energize the blower motor. Check blower operation.
2. Initiate a control signal to place the unit in the cooling mode. Cooling setpoint must be set below room temperature.
3. Be sure that the compressor and water control valve or loop pump(s) are activated.
4. Verify that the water flow rate is correct by measuring the pressure drop through the heat exchanger using the P/T plugs and comparing to unit capacity data in specification catalog.
5. Check the temperature of both the supply and discharge water (Refer to Unit Operating Parameters tables).
6. Check for an air temperature drop of 15°F to 25°F across the air coil, depending on the fan speed and entering water temperature.
7. Adjust the cooling setpoint above the room temperature and verify that the compressor and water valve or loop pumps deactivate.
8. Initiate a control signal to place the unit in the heating mode. Heating set point must be set above room temperature.
9. Check the temperature of both the supply and discharge water (Refer to Unit Operating Parameters tables).
10. Check for an air temperature rise of 20°F to 35°F across the air coil, depending on the fan speed and entering water temperature.
11. Adjust the heating setpoint below room temperature and verify that the compressor and water valve or loop pump deactivate.
12. During all testing, check for excessive vibration, noise or water leaks. Correct or repair as required.
13. Set system to desired normal operating mode and set temperature to maintain desired comfort level.
14. Instruct the owner/operator in the proper operation of the thermostat and system maintenance.

Note: Be certain to fill out and forward all warranty registration papers.

Operating Parameters

Single Speed Models

Entering Water Temp °F	Water Flow GPM/Ton	Cooling					
		Suction Pressure PSIG	Discharge Pressure PSIG	09-18 Superheat	09-18 Subcooling	Water Temp Rise °F	Air Temp Drop °F DB
50	1.5	127 - 144	205 - 225	5 - 10	10 - 14	18 - 22	18 - 22
	3.0	120 - 140	185 - 205	7 - 15	5 - 10	8 - 10	18 - 22
70	1.5	139 - 154	280 - 300	8 - 11	8 - 12	18 - 22	18 - 22
	3.0	137 - 152	250 - 270	9 - 12	7 - 11	8 - 10	18 - 22
90	1.5	143 - 158	360 - 380	8 - 11	9 - 13	18 - 22	16 - 20
	3.0	141 - 156	330 - 350	9 - 12	8 - 12	8 - 10	16 - 20

Entering Water Temp °F	Water Flow GPM/Ton	Heating					
		Suction Pressure PSIG	Discharge Pressure PSIG	09-18 Superheat	09-18 Subcooling	Water Temp Drop °F	Air Temp Rise °F DB
30	1.5	73 - 79	279 - 304	7 - 13	2 - 6	7 - 10	18 - 24
	3.0	79 - 85	285 - 310	8 - 14	2 - 6	3 - 6	20 - 26
50	1.5	103 - 109	308 - 333	8 - 12	4 - 8	8 - 11	20 - 26
	3.0	110 - 116	315 - 340	9 - 13	4 - 8	4 - 7	22 - 28
70	1.5	140 - 146	330 - 365	10 - 14	7 - 11	11 - 14	26 - 32
	3.0	146 - 153	340 - 375	10 - 14	7 - 11	7 - 10	28 - 34

Note: Cooling performance based on entering air temperatures of 80° F DB, 67° F WB.
 Heating performance based on entering air temperature of 70° F DB.

Operating Limits

Operating Limits	Cooling		Heating	
	(°F)	(°C)	(°F)	(°C)
Air Limits				
Min. Ambient Air	45	7.2	45	7.2
Rated Ambient Air	80	26.7	70	21.1
Max. Ambient Air	100	37.8	85	29.4
Min. Entering Air	50	10.0	40	4.4
Rated Entering Air db/wb	80.6/66.2	27/19	68	20.0
Max. Entering Air db/wb	110/83	43/28.3	80	26.7
Water Limits				
Min. Entering Water	30	-1.1	20	-6.7
Normal Entering Water	50-110	10-43.3	30-70	-1.1
Max. Entering Water	120	48.9	90	32.2

Notes:

Minimum/maximum limits are only for start-up conditions, and are meant for bringing the space up to occupancy temperature. Units are not designed to operate at the minimum/maximum conditions on a regular basis. The operating limits are dependant upon three primary factors: 1) water temperature, 2) return air temperature, and 3) ambient temperature. When any of the factors are at the minimum or maximum levels, the other two factors must be at the normal level for proper and reliable unit operation.

DEALER: _____
 PHONE #: _____ DATE: _____
 PROBLEM: _____
 MODEL #: _____
 SERIAL #: _____

Startup/Troubleshooting Form

COOLING CYCLE ANALYSIS

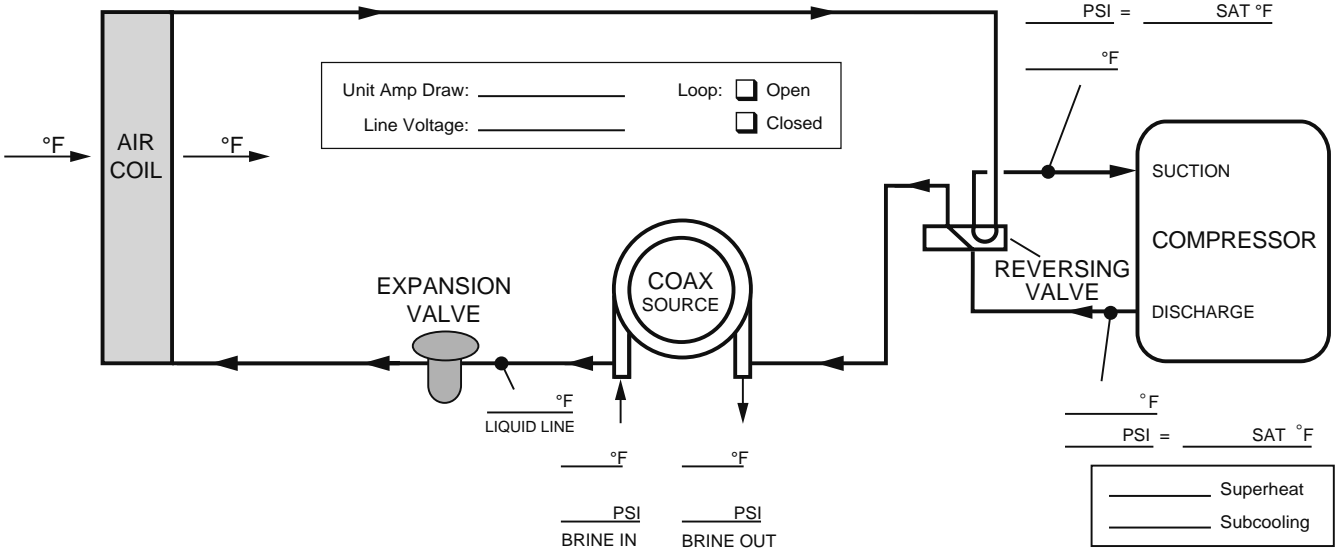

Heat of Extraction/Rejection = GPM x 500 (485 for water/antifreeze) x ΔT

Note: DO NOT hook up pressure gauges unless there appears to be a performance problem.

HEATING CYCLE ANALYSIS

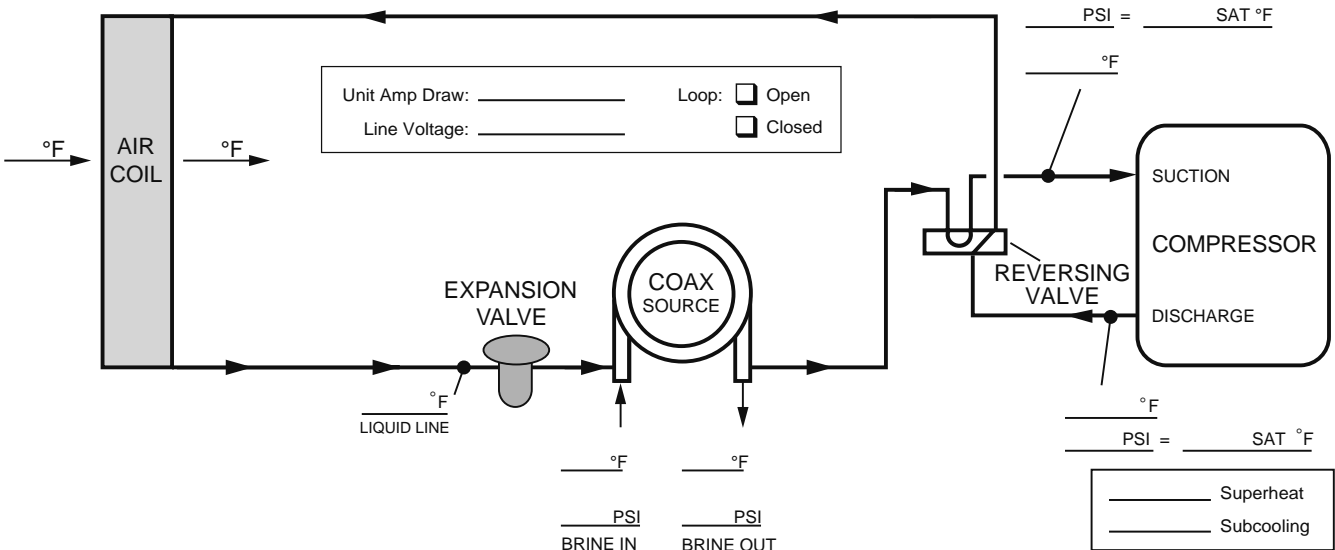

Pressure Drop

Model	GPM	Pressure Drop (psi)				
		30°F	50°F	70°F	90°F	110°F
09	1.2	1.0	0.9	0.8	0.7	0.6
	1.8	2.3	2.2	2.0	1.9	1.8
	2.5	3.8	3.7	3.5	3.3	3.1
12	1.5	0.9	0.8	0.7	0.6	0.5
	2.3	1.7	1.5	1.4	1.3	1.1
	3.5	3.0	2.7	2.5	2.4	2.2
15	2.0	1.7	1.6	1.5	1.4	1.3
	3.0	3.3	3.2	3.0	2.9	2.8
	4.5	5.7	5.5	5.3	5.1	4.9
18	3.0	1.7	1.6	1.5	1.4	1.3
	4.0	4.1	4.0	3.9	3.7	3.6
	5.5	7.9	7.6	7.4	7.2	6.9

12/14/09

Preventive Maintenance

Water Coil Maintenance

1. Keep all air out of the water. An open loop system should be checked to ensure that the well head is not allowing air to infiltrate the water line. Lines should always be airtight.
2. Keep the system under pressure at all times. It is recommended in open loop systems that the water control valve be placed in the discharge line to prevent loss of pressure during off cycles. Closed loop systems must have positive static pressure.

Note: On open loop systems, if the installation is in an area with a known high mineral content (125 PPM or greater) in the water, it is best to establish with the owner a periodic maintenance schedule so the coil can be checked regularly. Should periodic coil cleaning be necessary, use standard coil cleaning procedures which are compatible with either the cupronickel or copper water lines. Generally, the more water flowing through the unit the less chance for scaling.

Other Maintenance Filters

Filters must be clean to obtain maximum performance. They should be inspected monthly under normal operating conditions and be replaced when necessary. Units should never be operated without a filter.

Condensate Drain

In areas where airborne bacteria produce a slime in the drain pan, it may be necessary to treat chemically to minimize the problem. The condensate drain can pick up lint and dirt, especially with dirty filters. Inspect twice a year to avoid the possibility of overflow.

Blower Motors

Blower motors are equipped with sealed ball bearings and require no periodic oiling.

Air Coil

The air coil must be cleaned to obtain maximum performance. Check once a year under normal operating conditions and, if dirty, brush or vacuum (with a brush attachment) clean. Care must be taken not to damage the aluminum fins while cleaning.



CAUTION: Fin edges are sharp.

Replacement Procedures

Obtaining Parts

When ordering service or replacement parts, refer to the model number and serial number of the unit as stamped on the serial plate attached to the unit. If replacement parts are required, mention the date of installation of the unit and the date of failure, along with an explanation of the malfunctions and a description of the replacement parts required.

In-Warranty Material Return

Material may not be returned except by permission of authorized warranty personnel. Contact your local distributor for warranty return authorization and assistance.

Revision Guide

Pages:	Description:	Date:	By:
6, 15	Updated Chassis Installation Instructions, Flat Top Dimensional data	03 May 2016	MA
All	Updated Nomenclature and Wiring Schematics (ABC Controls)	1 Sept 2015	MA
All	Obsoleted PSC Option, Updated Nomenclature, Updated Wiring Schematics	04 Mar 2015	MA
All	Updated with All-Aluminum Air Coils	07 Mar 2014	DS
43	Added Revision Table	07 Mar 2014	DS



Product: **Aston Series Console**
Type: Geothermal Heat Pumps
Size: 0.75 - 1.5 Tons

Document Type: Installation Manual
Part Number: IM1010CGB
Release Date: 05/16