



INSTALLATION MANUAL

GEOHERMAL HEAT PUMPS



AFFORDABLE RENEWABLE CLEAN



ASTON SERIES AIR HANDLER

Table of Contents

Model Nomenclature	4
Initial Inspection	4
Physical Data	5
General Installation Information	5-11
Hydronic Models	12-13
Electrical Data	14-15
Wiring Schematics	16-18
ECM Blower Control	19
Blower Performance Data	20
Dimensional Data	21-24
Unit Startup	25
Replacement Procedures	26
Service Parts	26
Revision Guide	27

Model Nomenclature

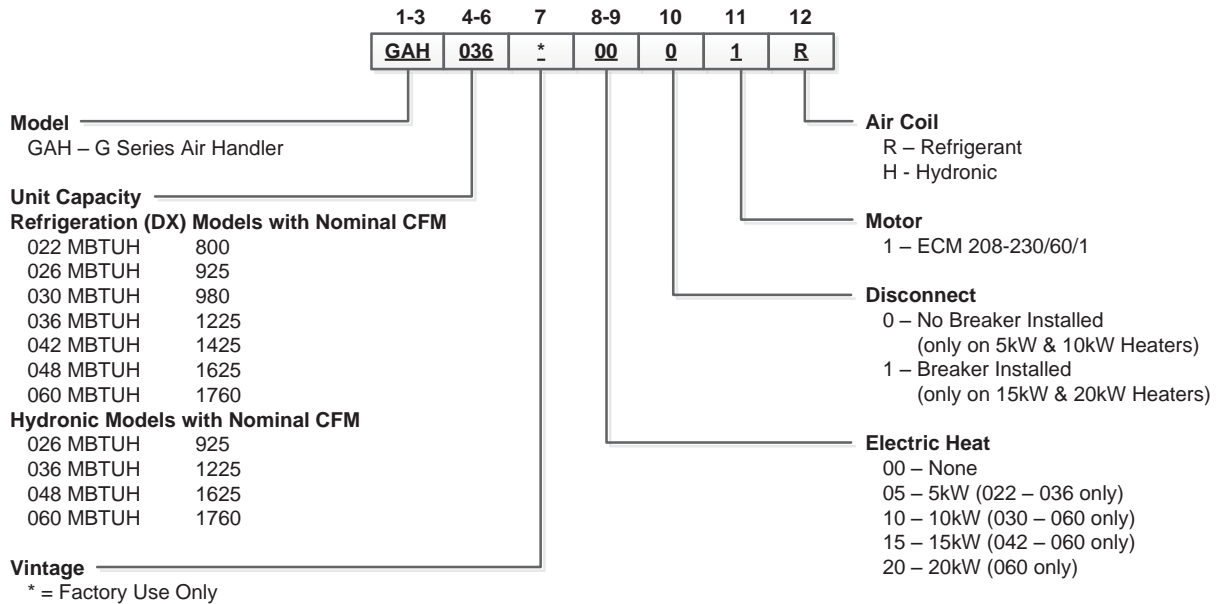

Rev.: 08 April 2013D

NOTE: To field convert the GAH042-060 to bottomflow air discharge, the NAHBC kit must be ordered.

Initial Inspection

When the equipment is received, all items should be carefully checked against the bill of lading to be sure all crates and cartons have been received. Examine units for shipping damage, removing the units from the packaging if necessary. Units in question

should also be internally inspected. If any damage is noted, the carrier should make the proper notation on the delivery receipt, acknowledging the damage.

Physical Data

Air Handler Model Number (Refrigerant)		GAH022	GAH026	GAH030	GAH036	GAH042	GAH048	GAH060
Evaporator Coil	Air Coil Total Face Area, ft2 [m2]	5.83 [0.54]						
	Tube outside diameter - in. [mm]	3/8 [9.52]						
	Number of rows	2			3			
	Fins per inch	12						
	Suction line connection - in. [mm] sweat	5/8 [15.87]				7/8 [22.22]		
	Liquid line connection - in. [mm] sweat	3/8 [9.52]						
Refrigerant		R-410a						
Nominal cooling capacity - tons [kW]		1.8 [6.44]	2.1 [7.59]	2.5 [8.79]	3 [10.55]	3.5 [12.30]	4 [14.06]	5 [17.58]
Condensate drain connection - (O.D.) in. [mm]		3/4 [19.05]						
Blower Wheel Size (Dia x W), in. [mm]		11 x 10 [279 x 254]						
Blower motor type/speeds		ECM variable speed						
Blower motor output - hp [W]		1/2 [373]				1 [746]		
Filter Standard - 1" [51mm] MERV3 disposable, in. [mm]		20 x 24 [508 x 635]						
Electrical characteristics (60hz)		208/230 - 1ph						
Shipping weight - lbs. [kg]		215 [97.52]				220 [99.79]		
Operating weight - lbs. [kg]		195 [88.45]				200 [90.71]		

4/28/14

Air Handler Model Number (Hydronic)		GAH026	GAH036	GAH048	GAH060
Hydronic Coil	Air Coil Total Face Area, ft2 [m2]	6.94 [0.64]			
	Tube outside diameter - in. [mm]	3/8 [9.52]			
	Number of rows	3			
	Fins per inch	13			
	Water In connection - in. [mm] sweat	7/8 [22.22]			
	Water Out connection - in. [mm] sweat	7/8 [22.22]			
Nominal cooling capacity - tons [kW]		2.1 [7.59]	3 [10.55]	4 [14.06]	5 [17.58]
Condensate drain connection - (O.D.) in. [mm]		3/4 [19.05]			
Blower Wheel Size (Dia x W), in. [mm]		11 x 10 [279 x 254]			
Blower motor type/speeds		ECM variable speed			
Blower motor output - hp [W]		1/2 [373]	1 [746]		
Filter Standard - 1" [51mm] MERV3 disposable, in. [mm]		20 x 24 [508 x 635]			
Electrical characteristics (60hz)		208/230 - 1ph			
Shipping weight - lbs. [kg]		220 [99.79]			
Operating weight - lbs. [kg]		200 [90.71]			

Note: Water connection dimensions are O.D.

8/15/14

General Installation Information

Safety Considerations

Warning: Before performing service or maintenance operations on a system, turn off main power switches to the equipment. Electrical shock could cause personal injury.

Installing and servicing heating and air conditioning equipment can be hazardous due to system pressure and electrical components. Only trained and qualified service personnel should install, repair or service heating and air conditioning equipment. Untrained personnel can perform the basic maintenance functions of cleaning coils and cleaning and replacing filters. All other operations should be performed by trained service personnel. When working on heating and air conditioning equipment, observe precautions in the literature, tags and labels attached to the unit and other safety precautions that may apply.

Follow all safety codes. Wear safety glasses and work gloves. Use a quenching cloth for brazing operations and have a fire extinguisher available.

Note: Local codes and regulations take precedent over any recommendations by the manufacturer. In addition to conforming to manufacturer's and local municipal building codes, the equipment should also be installed in accordance with the National Electric Code and National Fire Protection Agency recommendations.

General Installation Information cont.

Air Handler Sizing Selection

The Aston Series Air Handlers are designed for R410a refrigerant and should be matched with Aston indoor and outdoor series compressor section according to the table below.

Air Handler	Indoor Split Model (Single)	Indoor Split Model (Dual Capacity)	Outdoor Split Model (Dual Capacity)	Airflow(CFM)	Electric Heat (kW)
GAH022B***1R	103*022	-	-	800	5
GAH026B***1R	-	103*026	104*026	925	5
GAH030B***1R	103*030	-	-	980	5, 10
GAH036B***1R	103*036	-	-	1225	5, 10
GAH036B***1R	-	103*038	104*038	1225	5, 10
GAH042B***1R	103*042	-	-	1425	10, 15
GAH048B***1R	103*048	-	-	1625	10, 15
GAH048B***1R	-	103*049	104*049	1625	10, 15
GAH060B***1R	103*060	-	-	1760	10, 15, 20
GAH060B***1R	-	103*064	104*064	1760	10, 15, 20
GAH060B***1R	103*070	-	-	1760	10, 15, 20
GAH060B***1R	-	103*072	104*072	1760	10, 15, 20

6/9/08

Moving and Storage

If the equipment is not needed for immediate installation it should be left in its shipping carton and stored in a clean, dry area. Units must only be stored or moved in the normal "up" orientation.

Unit Location

Locate the unit in an indoor area that allows for easy removal of the filter and access panels (the air handler units are not approved for outdoor installation). Location should have enough space for service personnel to perform maintenance or repair. Provide sufficient room to make refrigerant, electrical and duct connections. If the unit is located in a confined space, such as a closet, provisions must be made for return air to freely enter the space by means of a louvered door, etc. The air handler section may be installed on any level surface strong enough to support its weight. When installed in a closet or on a stand, it should be mounted on vibration absorbing material slightly larger than the base to minimize vibration transmission to the building structure.

When installed in an attic or above a drop ceiling, the installation must conform to all local codes. If the unit is suspended and installed in the horizontal position, the entire length of the unit should be supported. If the application requires the air handler to be installed on the attic floor then the unit should be set in a full size secondary drain pan. In this case the secondary drain pan should be set on top of a vibration absorbing mesh. The secondary drain pan is usually placed on a plywood base. A secondary drain pan should be used when equipment is installed over a finished living area to provide protection from water damage in case of plugging of the air handler primary drain line. The secondary drain line should terminate somewhere that is easily visible by the homeowner. Be certain to show the homeowner the termination location of the secondary drain line and to explain its purpose.

Duct System

The duct system should be sized to handle the design airflow quietly and efficiently. To maximize sound attenuation of the unit blower, the supply and return plenums should include an internal duct liner of fiberglass or constructed of ductboard for the first few feet. On systems employing a metal duct system, canvas connectors should be used between the unit and the ductwork. If air noise or excessive airflow is a problem, the blower speed can be changed. Application of the unit to un-insulated metal ductwork in an unconditioned space will cause poor unit performance and allow condensation to form on the duct and possibly cause damage to the structure.

If the unit is connected to existing ductwork, check the duct system to ensure that it has the capacity to accommodate the air required for the unit application. If the duct is too small, as in the replacement of heating only systems, larger ductwork should be installed. All existing ductwork should be checked for leaks and repaired as necessary.

Condensate Drain

To facilitate condensate removal, the air handler should be pitched 1/4" towards the drain in both directions. The drain line contains cold water and should be insulated in unconditioned spaces to avoid drain line condensation from dripping on ceiling, etc. The drain pan has a primary and auxiliary drain connection. The 21S521A03 condensate hose assembly kit is provided to connect the drain pan's primary stainless steel tube to the PVC coupling. The air handler drain connections must be connected to a drain line and pitched away from the unit a minimum of 1/8" per foot to allow the condensate to flow away from the air handler. **A trap must be installed in the drain line** below the bottom of the drain pan to ensure free condensate flow (units are not internally trapped).

General Installation Information cont.

The primary condensate drain must be terminated to an open drain or sump. Do not connect the condensate drain to a closed waste system. An open vertical air vent should be installed to overcome line length, friction and static pressure. It is recommended that the auxiliary drain be connected to a drain line for all units. The auxiliary drain should be run to an area where the homeowner will notice it draining. The drain line should not be smaller than the drain connection at the condensate pan. If the air handler is located in an unconditioned space, water in the trap may freeze. It is recommended that the trap material be of a type that will allow for expansion of water when it freezes. Drain lines must be in conformance with local codes.

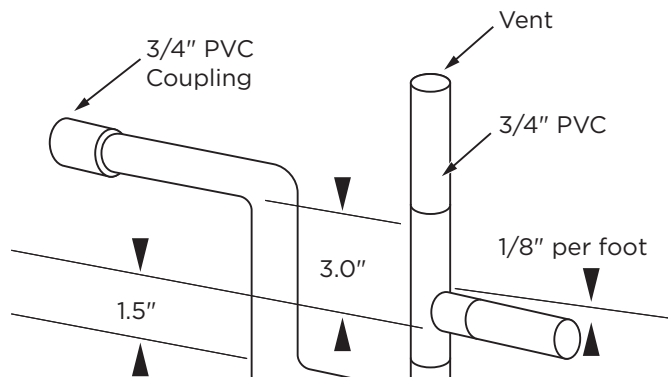

Air Handler Configuration

The air handler is factory configured for upflow and horizontal left hand air discharge installation (Figure 1). For bottomflow or horizontal right hand discharge, certain field modifications are required.

Warning: Do not lift or reposition the 'A' coil by grasping the copper tube header or distributor. This could cause a tubing fracture resulting in a refrigerant leak.

Figure 1 - Factory configuration is top discharge and horizontal left hand air discharge.

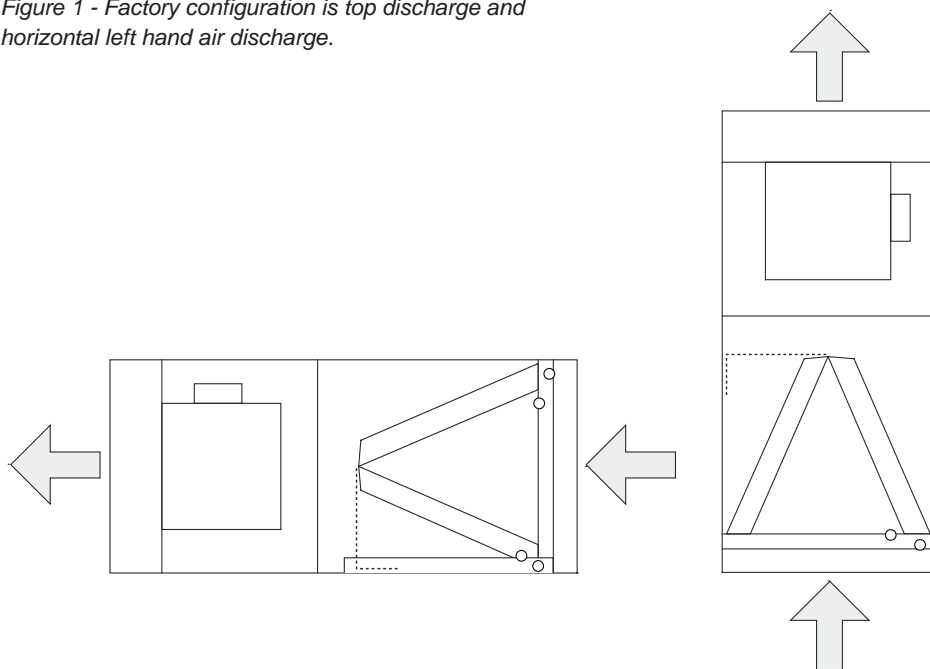

General Installation Information cont.

Bottomflow Application

To convert the air handler for bottomflow applications follow the steps shown below:

1. Remove all access panels. Disconnect the blower harnesses from the motor and loosen ground wire from blower. Remove the blower by removing 2 screws from the blower mounting bracket, and slide the blower assembly out the front. Remove the stiffener bracket in front of coil, 'A' coil/pan assembly and the horizontal drain pan. This will lighten the cabinet and make it easier to maneuver.
2. Rotate the cabinet 180° from the upright position so that the discharge air opening is located at the bottom and the return air opening is at the top.
3. Install the blower assembly into the blower discharge opening at the bottom of the cabinet by sliding the blower mounting bracket under the discharge support bracket and secure in place with 2 screws. The blower harness and motor ground wire should be reattached before sliding the blower into place.
4. On the 042-060 install the NAHBC bottomflow conversion kit per instructions in the kit. Failure to install this kit will result in condensate blow-off from the 'A' coil into the cabinet and ductwork.
5. Install the 'A' coil into the upper section of the cabinet as pictured in Figure 2. Attach the stiffener bracket into the two holes provided in the cabinet so that the bracket is in front of the coil. The horizontal drain pan is not needed and must be discarded. Plug the 2 drain hole openings in the access panel with the plugs provided.
6. Replace the access panels.
7. Bottom air discharge units require the supply air opening to be cut at least a 1/2" larger than the unit's air outlet.
8. When installed on combustible flooring, protect the edges of the floor opening with sheet metal over wrap or other non-combustible material.
9. Bottom air discharge units should be sealed well to the floor to prevent air leakage.

Figure 2 - Bottomflow Air Handler

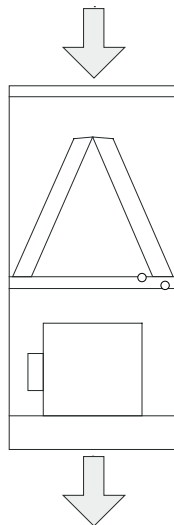

Horizontal Right Air Discharge Application

To convert air handler for horizontal right air discharge applications follow the steps shown below

1. Remove all access panels. Remove the stiffener bracket in front of the coil, 'A' coil assembly and the horizontal drain pan.
2. From the vertical upflow position, rotate the top of the cabinet 90° to the right and set in place.
3. Remove the support bracket mounted to the top plate of the 'A' coil. Rotate the 'A' coil support bracket 180° from its original position and re-attach into existing holes in the top plate of the coil. This must be done to prevent the 'A' coil from falling into the drain pan (Figure 3).
4. Move the horizontal drain pan from the left side of the 'A' coil to the right hand side of the 'A' coil. Place the 'A' coil and horizontal drain pan assembly into the cabinet so that the support bracket is resting in the horizontal drain pan as shown in Figure 3. Attach the stiffener bracket into the two holes provided in the cabinet so that the bracket is in front of the coil.
5. Remove the 2 drain plugs from the upper right of the access panel and install them on the lower left of the access panel. Replace the access panels.
6. If the unit is suspended, the entire length of the cabinet should be supported.

Figure 3 - Horizontal Right Hand Air Discharge

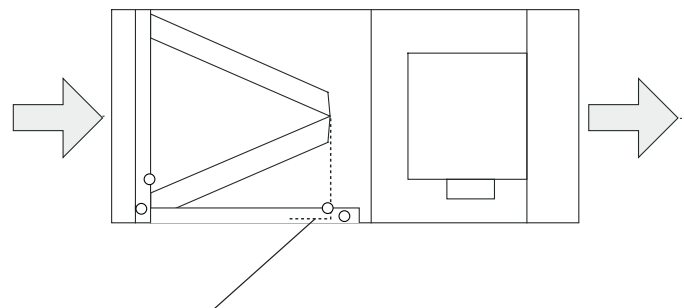

Rotate the coil support bracket to this position

Important: When removing the coil, there is possible danger of equipment damage and personal injury. Be careful when removing the coil assembly from the unit.

General Installation Information cont.

Air Handler Installation

The air handler is attached to the shipping pallet with screws. Prior to setting the unit in place remove the shipping screws located in the front base right behind the air filter access panel. Also remove the external shipping brackets at the rear of the cabinet.

An air filter must always be installed upstream of the air coil on the return air side of the air handler. An air filter is provided with the air handler. If there is limited access to the filter rack for normal maintenance, it is suggested that a return air filter grille be installed. In this instance the filter supplied with the air handler should be removed. Be sure that the return duct is properly installed and free of leaks to prevent dirt and debris from bypassing the filter and plugging the air coil.

The cabinet should be sealed so that unconditioned warm air can not enter the cabinet. Warm air will introduce moisture into the cabinet which could result in water blow-off problems, especially when installed in an unconditioned space. Make sure that the liquid line, suction line and drain line entry points into the cabinet are well sealed. Use the butyl tape supplied with the air handler to seal around the copper lines entering the cabinet.

All wall penetrations should be sealed properly. The line set should not come into direct contact with water pipes, floor joists, wall studs, duct work, floors, walls and brick. The line set should not be suspended from joists or studs with a rigid wire or strap which comes into direct contact with the tubing. Wide hanger straps which conform to the shape of the tubing are recommended. All line sets should be insulated with a minimum of 3/8" closed cell insulation. The line set insulation should be pliable, and should completely surround the refrigerant line. As in all R-410a equipment, a reversible liquid line filter drier is required to insure all moisture is removed from the system. This drier is factory installed in the series compressor section. This drier should be replaced whenever "breaking into" the system for service. All exterior insulation should be painted with UV resistant paint or covering to insure long insulation life.

Connection to the Coil

Connect the refrigerant line set to the 'A' coil tubes. Nitrogen should be bled through the system at 2 to 3 PSI to prevent oxidation inside the refrigerant tubing. Use a low silver phosphor copper braze alloy on all brazed connections. The air handler TXV bulb is secured to the 'A' coil for shipping. The indoor and outdoor compressor section is shipped with a factory charge and the service valves are not to be opened until the line set and air handler have been leak tested, purged and evacuated. A damp towel or heat sink should be used on the service valves to prevent damage caused by excessive heat.

Refer to the Refrigerant Line Sizing table to determine the proper line set configuration for the system being installed. Line sets over 60 feet in length are not recommended. If the line set is kinked or deformed and cannot be reformed, the bad section of pipe should

be replaced. A restricted line set will affect unit performance. Line sets should be routed as directly as possible, avoiding any unnecessary bends and turns.

Important Note:

The bulb will need to be attached to the suction line on the outside of the cabinet once the refrigerant line connections have been made.

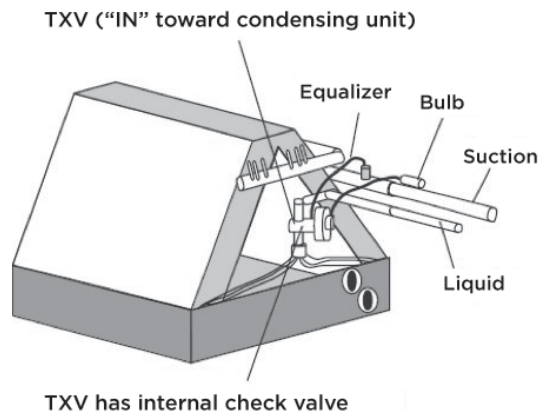

Leak Testing

The refrigeration line set must be pressurized and checked for leaks before purging and charging the unit. To pressurize the line set, attach refrigerant gauges to the service ports and add an inert gas (nitrogen or dry carbon dioxide) until pressure reaches 60 to 90 PSIG. Never use oxygen or acetylene to pressure test the system. Use an electronic leak detector or a good quality bubble solution to detect leaks on all connections made in the field. Be sure to check the service valve ports and stems for leaks. If a leak is found, repair it and repeat the above steps. For safety reasons do not pressurize the system above 150 PSIG. Purge pressure from the line set slowly when the pressure test is complete. The system is now ready for evacuation.

System Evacuation

Ensure that the line set and air coil are evacuated before opening service valves. The line set and air coil must be evacuated to 250 microns with a good quality vacuum pump and use a vacuum gauge to ensure that air and moisture are removed. With the system shut off from the vacuum pump a sufficient system vacuum is achieved when a 500 micron vacuum can be held for 30 minutes. A fast rise to atmospheric pressure indicates a leak, while a slower rise to around 1500 microns indicates moisture is still present in the system and further evacuation is required.

Refrigeration

The GAH series air handlers are supplied with an expansion device. Once the line set has been brazed into the air handler the txv bulb must be attached to the suction line outside of the cabinet and insulated with foam tape. Be careful not to crush the txv bulb by over-tightening the clamp. The txv supplied has an internal check valve so no external check valve is necessary. The

General Installation Information cont.

air handler TXV should be adjusted initially per TXV Superheat Adjustments table. Check sub-cooling and superheat, refrigerant charge and TXV may require further adjustment.

TXV Superheat Adjustment Procedure (see figure 4)

TXV's may require adjustment for a specific application.

1. Remove the seal cap from the bottom of the valve.
2. Turn the adjustment screw counterclockwise to increase superheat and clockwise to decrease superheat. One complete 360° turn changes the superheat approximately 3-4°F. You may need to allow as much as 30 minutes after the adjustment is made for the system to stabilize.
3. Once the proper superheat setting has been achieved replace and tighten the seal cap.

Warning – There are 8 total (360°) turns on the superheat adjustment stem from wide open to fully closed. When adjusting the superheat stem counterclockwise (superheat increase) and the stop is reached, any further counterclockwise turning adjustment will damage the valve.

NOTE: The air handler is factory supplied with a holding charge of dry nitrogen.

Charging the System

Refer to the unit Installation Manual for charging the system, checking sub-cooling/superheat and unit operating parameters. Refer to the Refrigerant Line Sizing table for initial refrigerant charge amounts used with the compression section.

TXV Superheat Adjustments

Part Number	GAH022, GAH026, GAH030	GAH036	GAH042	GAH048	GAH060
33P609-01	factory set				
33P609-03		factory set			
33P609-05			factory set	open 2 turns	
33P609-06					open 2 turns

Note: When installing these air handlers, follow the table for initial txv setting.

Check sub-cooling and superheat to verify final setting.

Refrigerant Line Sizing

Unit Size	Air Handler	20 feet		40 feet		60 feet		Factory Charge (oz.)	*Charge Amount with GAH Air Handler (oz.)
		Suction	Liquid	Suction	Liquid	Suction	Liquid		
022	GAH022	5/8" OD	3/8" OD	5/8" OD	3/8" OD	3/4" OD	3/8" OD	56	78
030	GAH030	5/8" OD	3/8" OD	3/4" OD	3/8" OD	3/4" OD	3/8" OD	56	78
036	GAH036	5/8" OD	3/8" OD	3/4" OD	3/8" OD	3/4" OD	1/2" OD	56	86
042	GAH042	3/4" OD	3/8" OD	3/4" OD	3/8" OD	7/8" OD	1/2" OD	74	99
048	GAH048	3/4" OD	3/8" OD	7/8" OD	3/8" OD	7/8" OD	1/2" OD	90	115
060	GAH060	7/8" OD	1/2" OD	7/8" OD	1/2" OD	1-1/8" OD	1/2" OD	92	112
070	GAH060	7/8" OD	1/2" OD	7/8" OD	1/2" OD	1-1/8" OD	1/2" OD	108	132
026	GAH026	5/8" OD	3/8" OD	3/4" OD	3/8" OD	3/4" OD	1/2" OD	52	74
038	GAH036	3/4" OD	3/8" OD	3/4" OD	3/8" OD	3/4" OD	1/2" OD	56	86
049	GAH048	3/4" OD	3/8" OD	7/8" OD	3/8" OD	7/8" OD	1/2" OD	90	115
064	GAH060	7/8" OD	1/2" OD	7/8" OD	1/2" OD	1-1/8" OD	1/2" OD	92	112
072	GAH060	7/8" OD	1/2" OD	7/8" OD	1/2" OD	1-1/8" OD	1/2" OD	104	132

NOTES: * The "Charge Amount with GAH Air Handler" column is based on the charge amount for a GAH Air Handler+Compressor Section/Split. Additional charge will have to be added accordingly for line set length.

After Charge is added adjustments can be made to get appropriate subcooling and superheat.

Additional charge for R-410A is 0.50 oz. per ft. for 3/8 in. and 1.0 oz. per ft. for 1/2 in. tube.

Longer line sets will significantly reduce capacity and efficiency of the system as well as adversely effect the system reliability due to poor oil return.

General Installation Information cont.

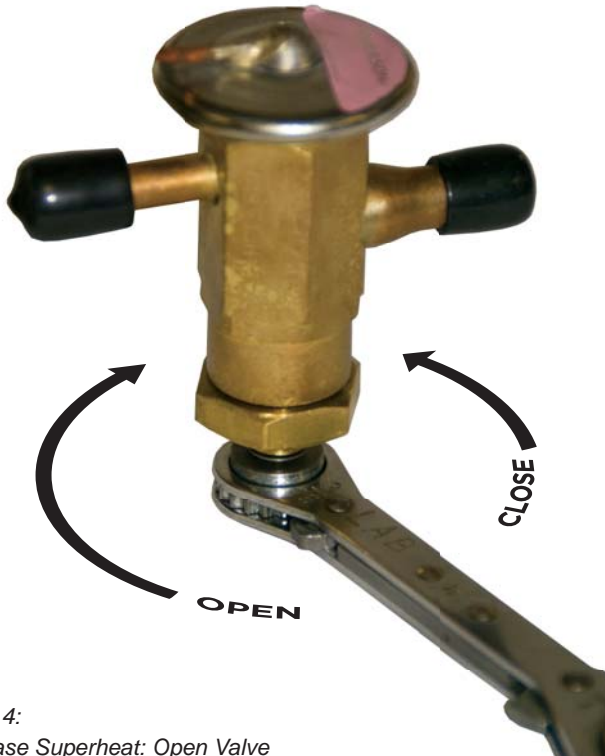

Figure 4:
Decrease Superheat: Open Valve
Increase Superheat: Close Valve

Hydronic Models

The water heater and hydronic air handler must be located indoors and not subject to freezing temperatures. The water heater must be installed in accordance to local codes and its own installation instructions. The piping between the water heater and air handler should be kept to a minimum. Piping should be sized to allow for water velocities of 2'-4' per second. At average water velocities, air bubbles should be carried along the piping to an air separator where they can be discharged from the system. Water velocities greater than 4' per second could cause flow noise and should be avoided. If water lines pass through an unconditioned space they should be protected to prevent them from freezing. Valves should be installed to allow system isolation. All closed loop hydronic systems must be equipped with an expansion tank to allow room for the heated liquid to expand. A system is considered closed when a check valve or backflow prevention valve is installed in the cold water pipe upstream of the water heater.

Once piping is complete all air must be purged from the water lines. There is a dole valve at the top of the hydronic coil header that can be opened to purge air from the coil. There is also a plug at the bottom of the hydronic coil header for draining the coil.

Dole valve for air purging



Plug for coil drainage.

Typical Installation. See the Hydronic Application Guide for other applications

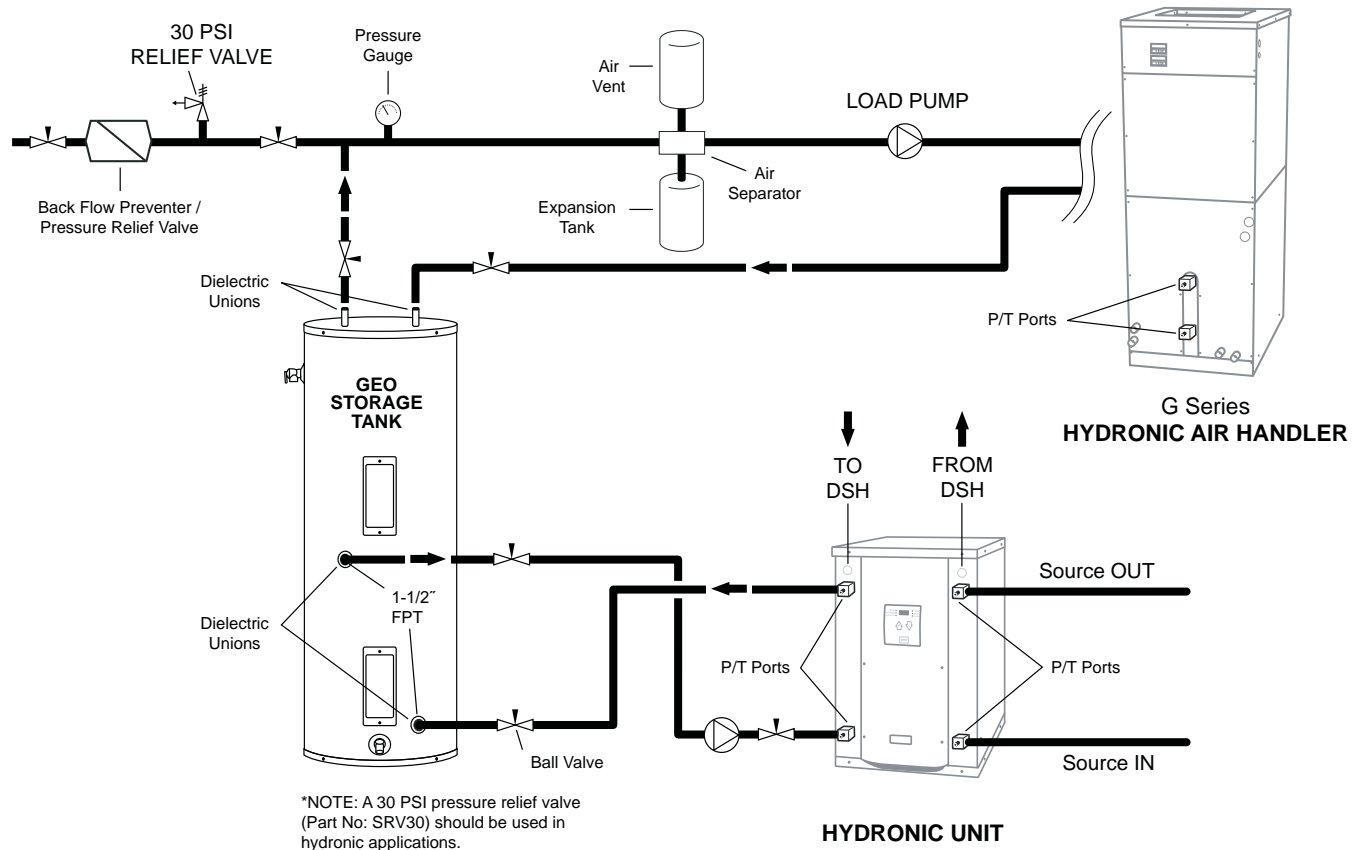

Hydronic Models cont.

Water Pressure Drop - Hydronic Coil

Flow gpm	Pressure Drop (PSI)						
	40°F	50°F	60°F	100°F	110°F	120°F	130°F
3.0	0.5	0.5	0.5	0.4	0.4	0.4	0.4
4.5	0.9	0.9	0.9	0.8	0.8	0.8	0.8
6.0	1.4	1.4	1.4	1.2	1.2	1.2	1.2
9.0	2.8	2.6	2.5	2.4	2.4	2.4	2.3
12.0	4.6	4.4	4.2	4.0	4.0	4.0	3.9
15.0	7.0	6.8	6.6	6.0	6.0	5.9	5.8

Coil Capacity vs. Entering Water Temperature

EAT °F	Entering Water Temperature °F					
	100	110	120	130	140	150
65	44%	56%	69%	81%	94%	106%
70	37%	50%	63%	75%	87%	100%

Electrical Data

All field wiring must comply with local and national fire, safety and electrical codes. Be sure the available power is the same voltage and phase as that shown on the unit serial plate. Refer to the unit Electrical Data table for fuse and circuit breaker sizing. The thermostat should be connected to the air handler and to the compressor section. Line voltage power should be supplied to the breakers on air handlers with 15kW and 20kW heater kits (see the electric heat control section picture).

15kW and 20kW Wiring Instructions

If two separate circuits are used to supply power to the auxiliary heat kit, the installer will need to verify that each leg of the auxiliary circuit breakers are wired from the power supply correctly in order for the electric heat kit to operate properly. This can be done by measuring the supply side voltage of the auxiliary heat circuit breakers. Put a voltmeter on the L2 side of Circuit Breaker One and on the L2 side of Circuit Breaker Two. The voltmeter should read approximately 0 volts. If the meter reads high voltage, the auxiliary heat breakers need to be rewired so that breakers in the auxiliary heat kit match the wiring of the Disconnect Panel breakers. Meaning, L1 and L2 from one breaker in the disconnect panel must connect to L1 and L2 at one of the auxiliary heat circuit breakers and L1 and L2 from the other breaker in the disconnect panel must connect to L1 and L2 of the other auxiliary heat circuit breaker, making sure that the L1 and L2 from each disconnect breaker matches the L1 and L2 at each of the auxiliary heat breakers.

On air handlers with no electric heat installed, or with 5kW and 10kW heater kits the power should be supplied to L1 and L2 lugs on PB (see air handler control section picture).

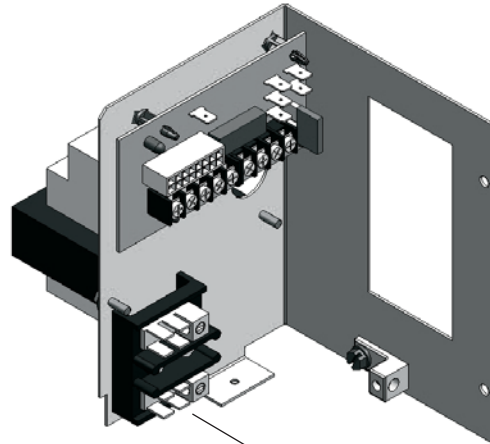

*Air Handler Control Section:
Power should be supplied to PB on air handlers with no electric heat and 5kW or 10kW heaters.*

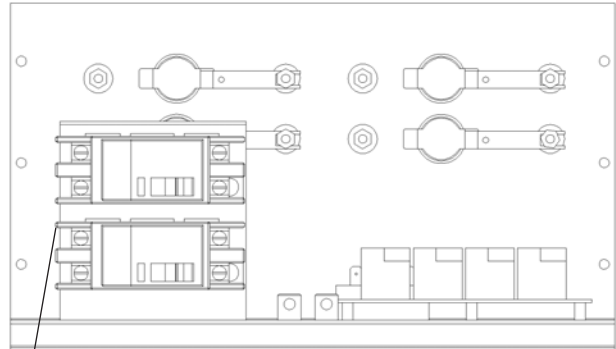

*Electric Heat Control Section:
Power should be supplied to the breakers on air handlers with 15kW and 20kW heaters.*

Electrical Data cont.

Model	Electric Heat Capacity		Supply Circuit	Aux. Heat Minimum CFM	Rated Voltage	Voltage Min/Max	Blower Motor FLA	Heater Ampacity		Total Unit FLA		Minimum Circuit Ampacity		Maximum Fuse/HACR			
	KW	BTUH						208v	240v	208v	240v	208v	240v	208v	240v	208v	240v
	240v	240v															
022	0	0	-		208-230/60/1	197/253	4.0	-	-	4.0	4.0	5.0	5.0	10	10		
	4.8	16,382	single	740			4.0	17.3	20.0	21.3	24.0	26.6	30.0	30.0	30	30	
026	0	0	-				4.0	-	-	4.0	4.0	5.0	5.0	10	10		
	4.8	16,382	single	740			4.0	17.3	20.0	21.3	24.0	26.6	30.0	30.0	30	30	
030	0	0	-				4.0	-	-	4.0	4.0	5.0	5.0	10	10		
	4.8	16,382	single	740			4.0	17.3	20.0	21.3	24.0	26.6	30.0	30.0	30	30	
	9.6	32,765	single	900			4.0	34.7	40.0	38.7	44.0	48.4	55.0	50	60		
036	0	0	-				4.0	-	-	4.0	4.0	5.0	5.0	10	10		
	4.8	16,382	single	740			4.0	17.3	20.0	21.3	24.0	26.6	30.0	30.0	30	30	
	9.6	32,765	single	900			4.0	34.7	40.0	38.7	44.0	48.4	55.0	50	60		
042	0	0	-				7.0	-	-	7.0	7.0	8.8	8.8	15	15		
	9.6	32,765	single	900			7.0	34.7	40.0	41.7	47.0	52.1	58.8	60	60		
	14.4	49,147	single				7.0	52.0	60.0	59.0	67.0	73.8	83.8	80	90		
	14.4	49,147	L1/L2 L3/L4	1,275			7.0	34.7	40.0	41.7	47.0	52.1	58.8	60	60		
048	0	0	-				-	17.3	20.0	17.3	20.0	21.6	25.0	25	25		
	9.6	32,765	single	900			7.0	-	-	7.0	7.0	8.8	8.8	15	15		
	14.4	49,147	single				7.0	34.7	40.0	41.7	47.0	52.1	58.8	60	60		
	14.4	49,147	L1/L2 L3/L4	1,275			7.0	52.0	60.0	59.0	67.0	73.8	83.8	80	90		
	14.4	49,147	L1/L2 L3/L4	1,275			7.0	34.7	40.0	41.7	47.0	52.1	58.8	60	60		
060	0	0	-				-	17.3	20.0	17.3	20.0	21.6	25.0	25	25		
	9.6	32,765	single	900			7.0	-	-	7.0	7.0	8.8	8.8	15	15		
	14.4	49,147	single				7.0	34.7	40.0	41.7	47.0	52.1	58.8	60	60		
	14.4	49,147	L1/L2 L3/L4	1,275			7.0	52.0	60.0	59.0	67.0	73.8	83.8	80	90		
	14.4	49,147	L1/L2 L3/L4	1,275			7.0	34.7	40.0	41.7	47.0	52.1	58.8	60	60		
	19.2	65,530	single				-	17.3	20.0	17.3	20.0	21.6	25.0	25	25		
	19.2	65,530	L1/L2 L3/L4	1,700			7.0	69.3	80.0	76.3	87.0	95.4	108.8	100	110		
				7.0			34.7	40.0	41.7	47.0	52.1	58.8	60	60			
				-			34.7	40.0	34.7	40.0	43.4	50.0	50	50			

7/11/08

Rated Voltage of 208/230/60/1
HACR circuit breaker in USA only

Low Voltage Point to Point Wiring

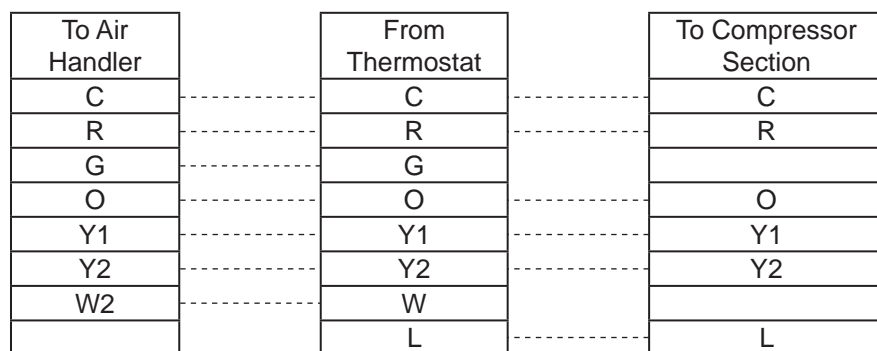

Air Handler transformer must be 75VA.

5/29/08

Wiring Schematics cont.

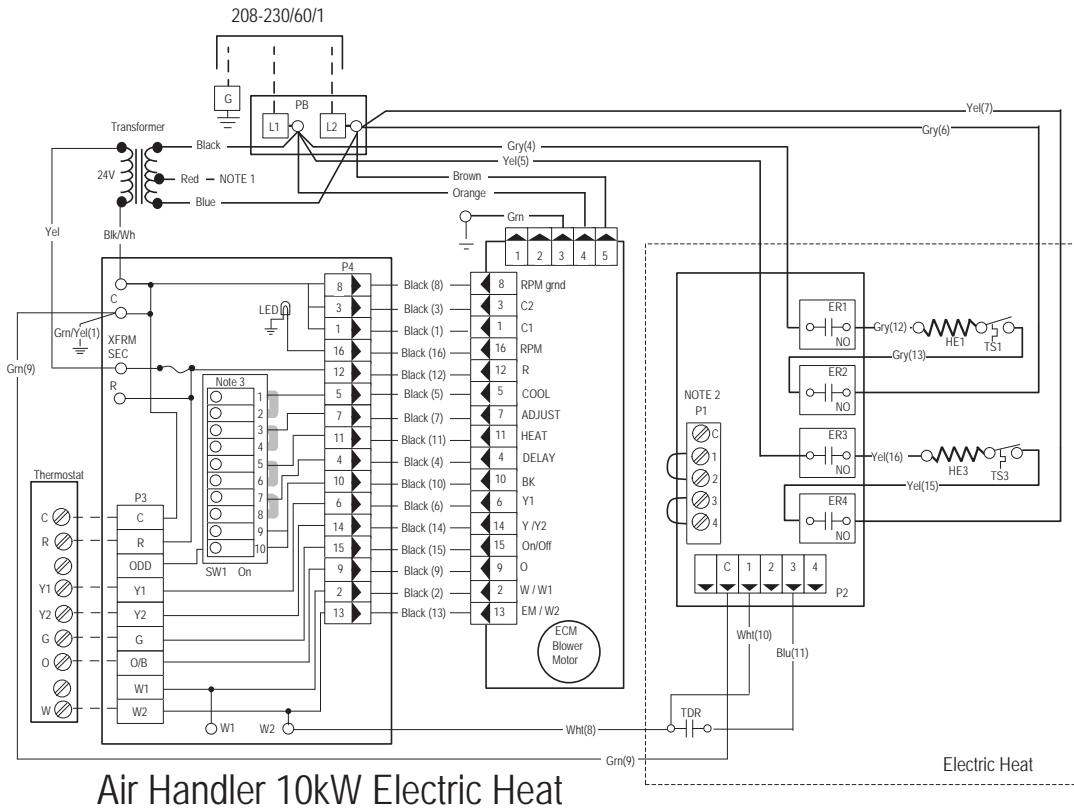
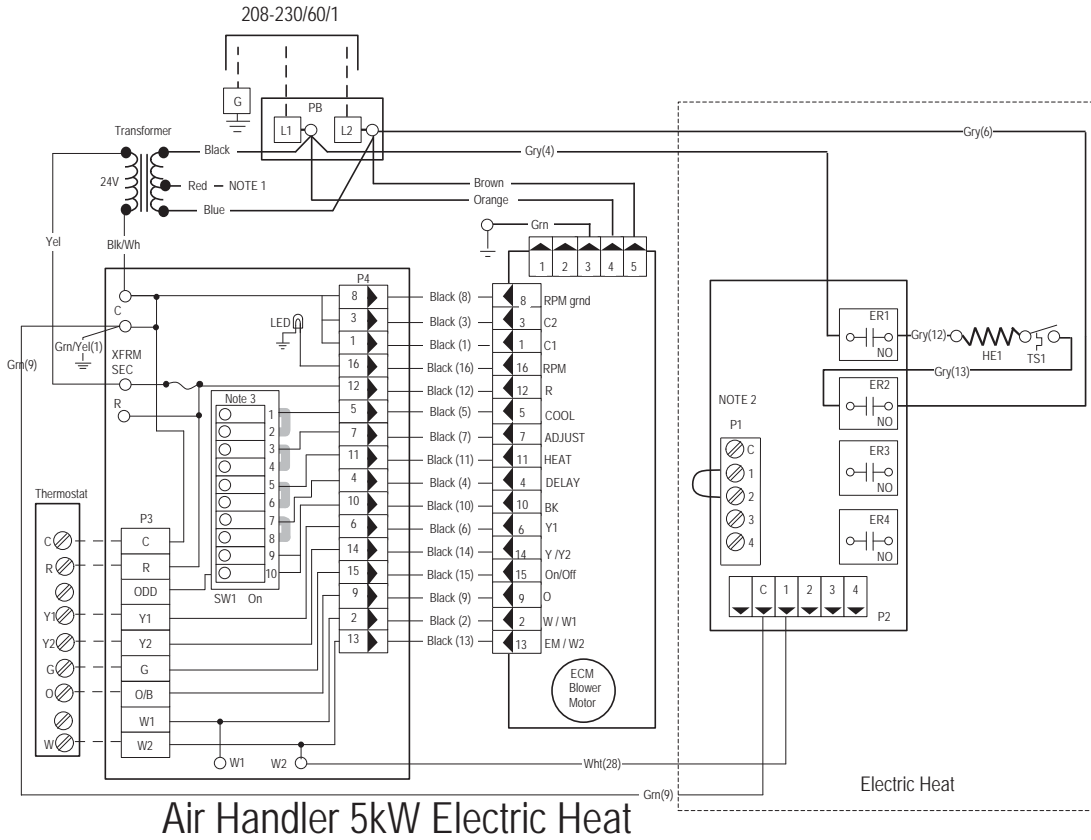

Wiring Schematics cont.

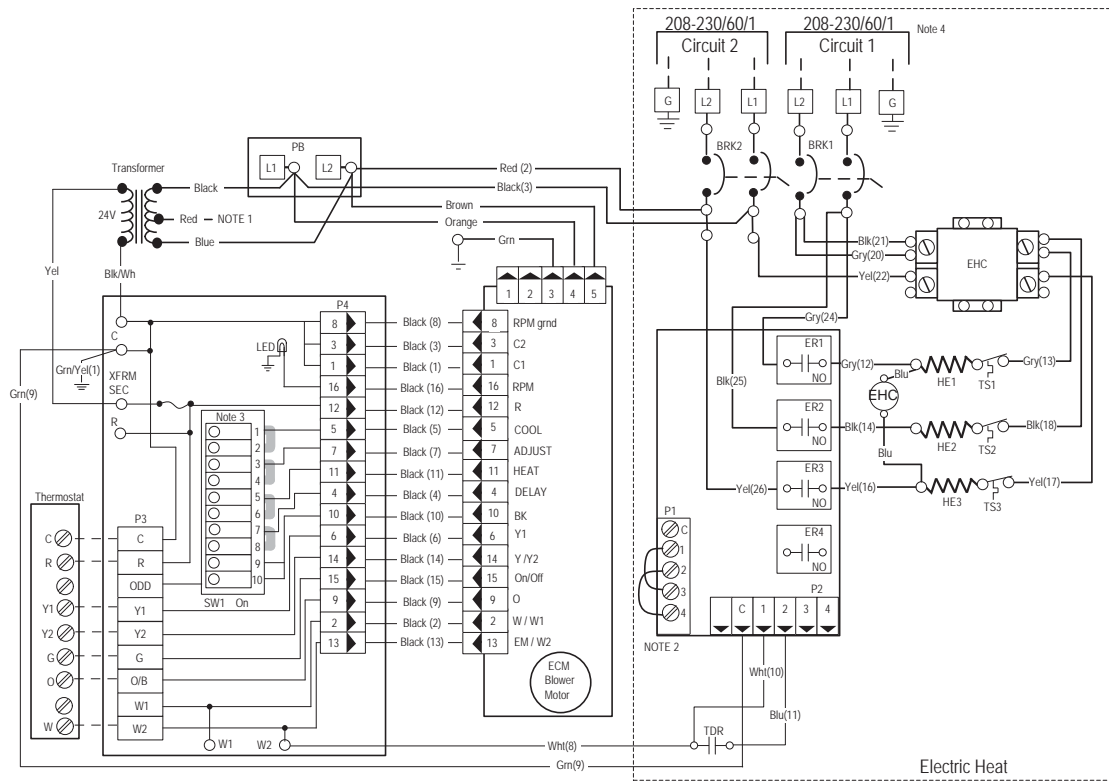

Air Handler w/ 15kW Electric Heat

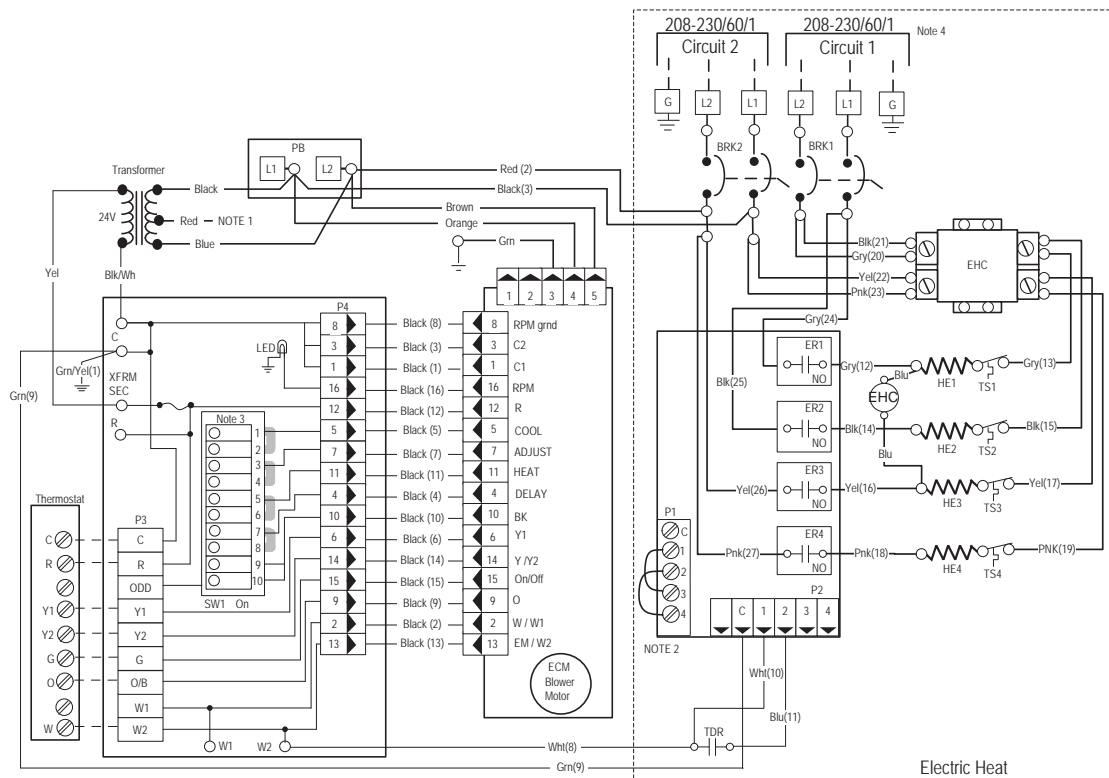

Air Handler w/ 20kW Electric Heat

ECM Blower Control

The ECM blower motor is controlled by an interface board installed in the air handler and allows field selectable CFM settings. The interface board receives inputs from the thermostat and converts them to signals used by the ECM motor. There are four different airflow settings that are field selectable via DIP switches (see Blower Performance table).

Cooling/Heating settings

The cooling/heating CFM settings determine the normal cooling/heating CFM when the unit is not in dehumidification mode or auxiliary heat mode. DIP switches 1 and 2 'off' is the lowest CFM setting while with DIP switches 1 and 2 'on' is the highest CFM setting. To prevent air coil freeze up, the lowest CFM setting can not be used when dehumidification mode is selected. DIP 9 must be 'on' to enable normal airflow settings.

Dehumidification Mode settings

This setting provides for field selection of humidity control (via setting DIP 9 'off'). The cooling airflow settings are determined by the Cooling/Heating DIP switch settings above. Dehumidification mode reduces the selected normal cooling CFM by 15%-20% which increases the moisture removing capability of the heat pump. To prevent air coil freeze up, the lowest CFM setting can not be used when dehumidification mode is selected.

Dehumidification Mode (Continuous) – This mode is selected via setting DIP 9 'off' on the ECM interface board and will be engaged whenever an 'O' input is present. In this mode any time the unit is operating in cooling mode, it will run at a CFM level 15%-20% lower than the selected normal cooling CFM.

NOTE: Do not select dehumidification mode if the lowest Cooling/Heating airflow level is selected (DIPS 1 & 2 off).

Auxiliary Heat settings - DIP 5 & 6 on the ECM interface board are used to select the desired CFM in auxiliary/emergency heat mode. Whenever auxiliary or emergency electric heat is energized this air flow setting will be used.

Blower Performance

Blower Performance Variable Speed ECM

Model	Max ESP (wg)	Blower Motor (hp)	HP CFM Setting		Normal Mode Htg & Clg			Dehumidification Mode Clg				Aux CFM Setting		Aux Emerg Mode
			S1	S2	Stg 2	Stg 1	Blower	S9	Stg 2	Stg 1	Blower	S5	S6	
022	0.50	1/2	On	On	900	700	450	Off	775	600	450	On	On	1000
	0.50	1/2	Off	On	800	625	400	Off	680	530	400	Off	On	800
	0.50	1/2	On	Off	700	540	375	Off	600	450	375	On	Off	775
	0.50	1/2	Off	Off	640	480	350					Off	Off	740
026	0.50	1/2	On	On	1050	800	525	Off	850	700	525	On	On	1150
	0.50	1/2	Off	On	925	725	475	Off	760	620	475	Off	On	950
	0.50	1/2	On	Off	800	625	425	Off	670	540	425	On	Off	925
	0.50	1/2	Off	Off	740	575	400					Off	Off	825
030	0.50	1/2	On	On	1150	950	600	Off	975	775	600	On	On	1250
	0.50	1/2	Off	On	980	780	500	Off	825	640	500	Off	On	1000
	0.50	1/2	On	Off	900	700	440	Off	750	580	440	On	Off	975
	0.50	1/2	Off	Off	800	630	425					Off	Off	900
036	0.50	1/2	On	On	1300	1025	760	Off	1105	871	760	On	On	1300
	0.50	1/2	Off	On	1225	950	685	Off	1041	808	685	Off	On	1250
	0.50	1/2	On	Off	1150	850	620	Off	940	690	620	On	Off	1225
	0.50	1/2	Off	Off	1075	800	550					Off	Off	1200
042	0.75	1	On	On	1500	1100	750	Off	1250	900	750	On	On	1550
	0.75	1	Off	On	1425	1010	650	Off	1180	840	650	Off	On	1450
	0.75	1	On	Off	1300	975	635	Off	1080	800	635	On	Off	1400
	0.75	1	Off	Off	1150	850	625					Off	Off	1275
048	0.75	1	On	On	1700	1300	975	Off	1400	1080	975	On	On	1700
	0.75	1	Off	On	1625	1240	875	Off	1350	1025	875	Off	On	1550
	0.75	1	On	Off	1450	1100	750	Off	1200	900	750	On	Off	1525
	0.75	1	Off	Off	1300	1000	675					Off	Off	1400
060	0.75	1	On	On	1850	1750	1175	Off	1540	1450	1175	On	On	1850
	0.75	1	Off	On	1760	1625	1050	Off	1460	1350	1050	Off	On	1760
	0.75	1	On	Off	1720	1575	1015	Off	1425	1300	1015	On	Off	1725
	0.75	1	Off	Off	1680	1525	975		1428			Off	Off	1700

Factory CFM settings are in boldface

CFM is controlled within 5% up to maximum ESP

Maximum ESP includes allowance for wet coil and standard filter

DIP switch 9 must be 'OFF' to select dehumidification mode

2/3/10

	DIPS	Switch Description
Air Handler DIP Switches	1	Used to set normal CFM
	2	
	3	Not used
	4	
	5	Used to set aux./emergency heat CFM
	6	
	7	Not used
	8	
	9	Used to set dehumidification CFM
	10	Not used

Dimensional Data - DX Air Handler

Top Flow/Horizontal Unit Configuration

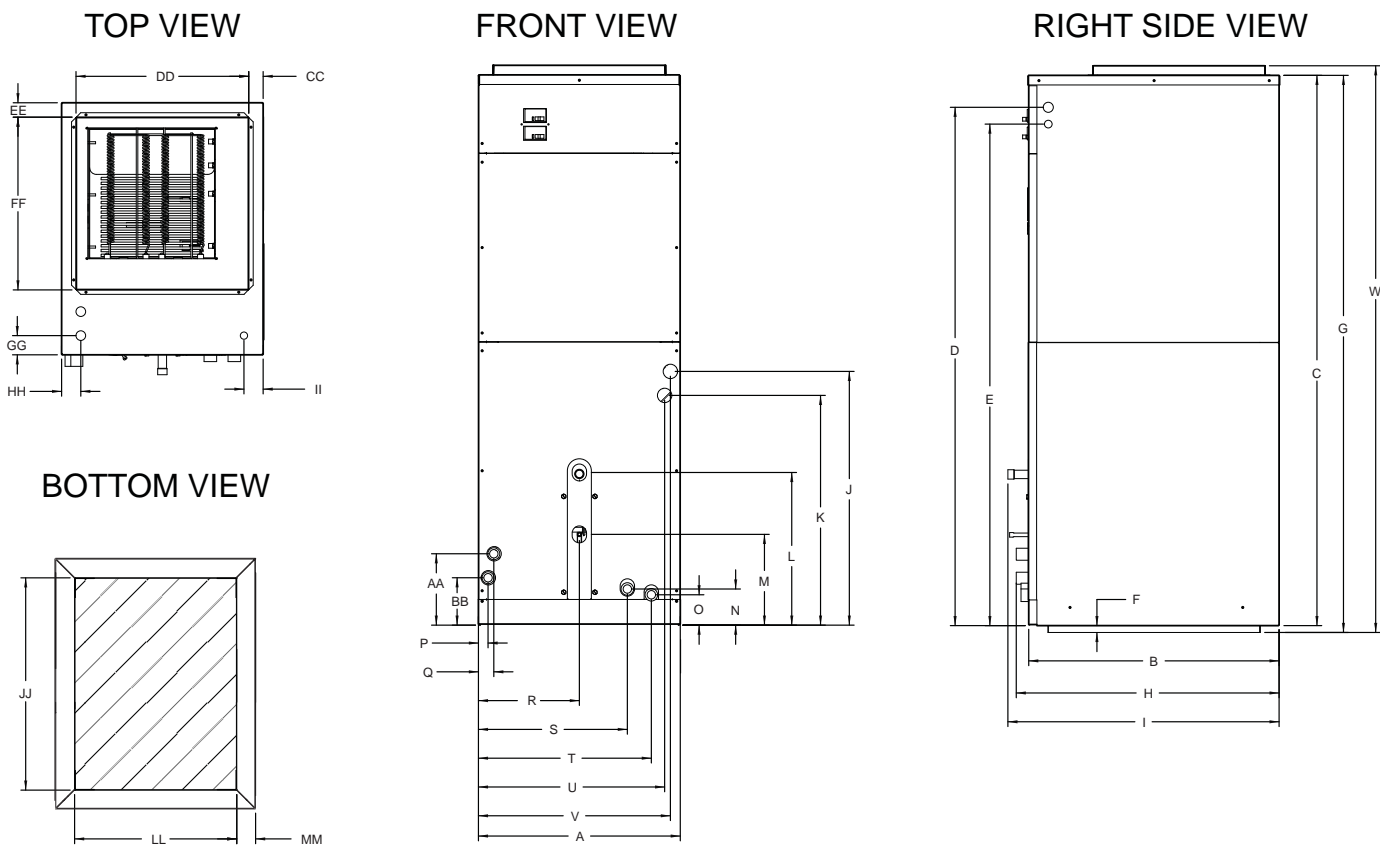

Topflow/ Horizontal Configuration	Overall Cabinet			Refrigerant/Water Connections								Refrigerant/Water Connections								
	A Width	B Depth	C Height	D 3/4" cond Power Supply	E 1/2" cond Low Voltage	F Return Air Duct Flange	G	H	I	J	K	L Suction / Water Out	M Liquid / Water In	N	O	P	Q	R	S	
026-060	in.	21.0	26.1	57.3	54.0	52.3	0.7	58.1	27.4	28.3	26.8	24.3	16.0	9.8	4.0	3.1	0.8	1.5	10.5	15.5
	cm.	53.4	66.3	145.6	137.2	132.7	1.8	147.4	69.6	71.8	68.1	61.7	40.6	24.9	10.2	7.9	2.0	3.9	26.7	39.4

S	T	U	V	W	X	Y	Z	AA	BB	CC	DD	EE	FF	GG 1" cond Power Supply	HH 1/2" cond Low Voltage	II	JJ	KK	LL	MM
15.5	18.0	19.5	20.1	59.5	15.1	53.1	51.3	7.8	5.2	1.5	18.0	1.5	18.0	2.0	2.0	2.0	22.1	2.0	16.9	1.96
39.4	45.8	49.5	51.0	151.1	38.4	134.9	130.2	19.8	13.2	3.8	45.7	3.8	45.7	5.1	5.1	5.1	56.2	5.0	42.9	5.0

Condensate is stainless steel 3/4" O.D. tube
 Discharge flange is field installed and extends 1" (25.4 mm) from cabinet

Rev: 4/28/14

Dimensional Data DX Air Handler

Bottom Flow Unit Configuration

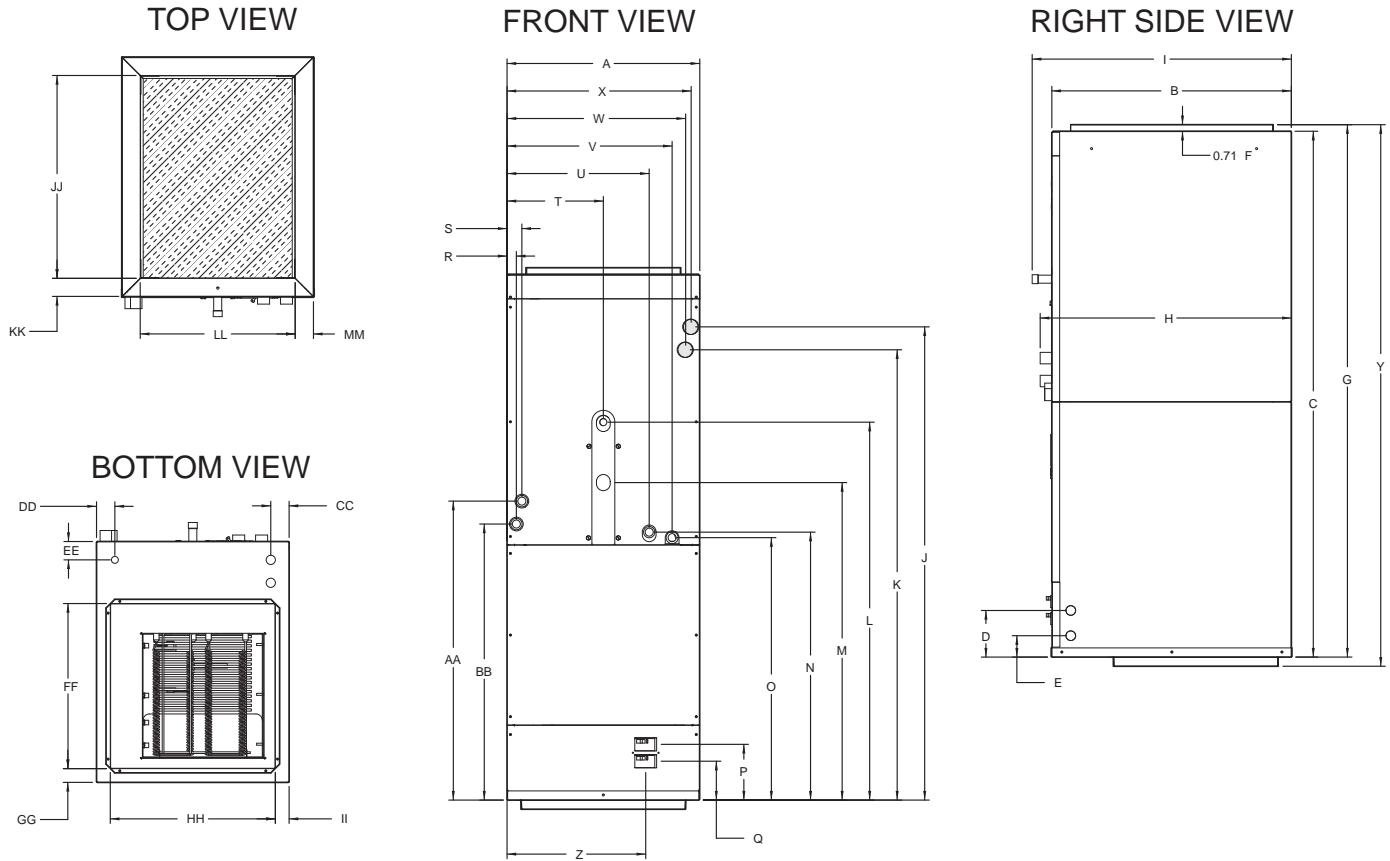

Bottomflow Configuration	Overall Cabinet											Refrigerant/Water Connections							
	A	B	C	D	E	F	G	H	I	J	K	L	M	N	O	P	Q	R	
	Width	Depth	Height	3/4" cond Low Voltage	1" cond Power Supply	Return Air Duct Flange						Suction / Water Out	Liquid / Water In						
026-060	in. cm.	21.0 53.4	26.1 66.3	57.3 145.6	5.1 12.9	3.3 8.5	0.7 1.8	58.1 147.4	27.4 69.6	28.3 71.8	51.9 131.8	49.4 125.5	41.2 104.7	34.9 88.7	29.2 74.2	28.2 71.6	6.1 15.4	4.2 10.8	0.9 2.4

											CC	DD	EE								
S	T	U	V	W	X	Y	Z	AA	BB		1" cond Power Supply	1/2" cond Low Voltage	FF	GG	HH	II	JJ	KK	LL	MM	
1.5	10.5	15.5	18.0	19.5	20.1	59.1	15.1	32.9	30.4		2.0	2.0	2.0	18.0	1.5	18.0	1.5	22.1	2.0	16.9	1.96
3.9	26.7	39.4	45.8	49.5	51.0	150.0	38.4	83.6	77.2		5.1	5.1	5.1	45.7	3.8	45.7	3.8	56.2	5.0	42.9	5.0

Condensate is stainless steel 3/4" O.D. tube
 Discharge flange is field installed and extends 1" (25.4 mm) from cabinet

Rev: 4/28/14

Dimensional Data - Hydronic Air Handler

Top Flow/Horizontal Unit Configuration

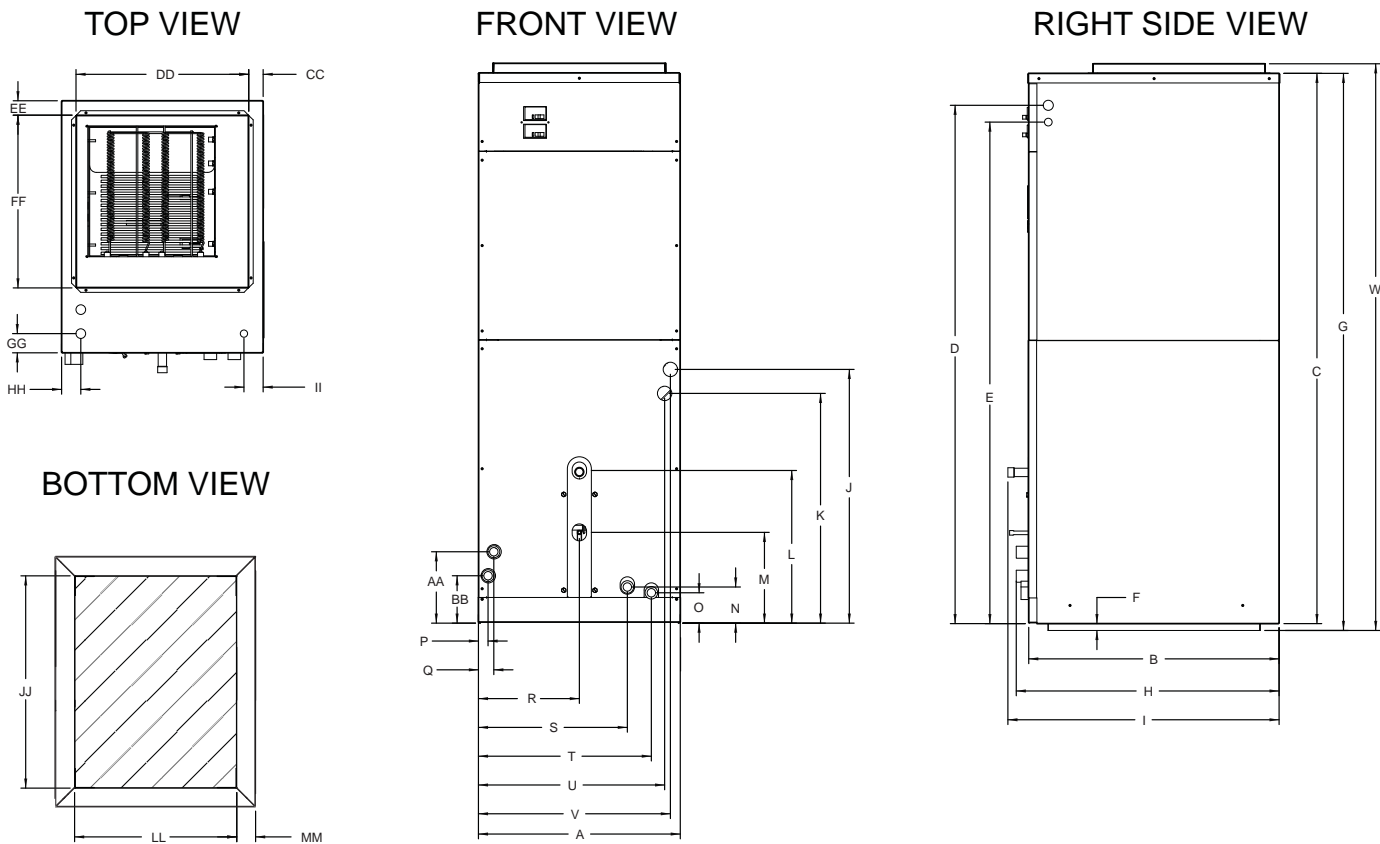

BOTTOM VIEW

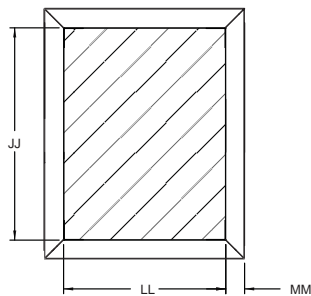

Topflow/ Horizontal Configuration	Overall Cabinet			Refrigerant/Water Connections																
	A	B	C	D	E	F	G	H	I	J	K	L	M	N	O	P	Q	R	S	
	Width	Depth	Height	3/4" cond Power Supply	1/2" cond Low Voltage	Return Air Duct Flange						Suction / Water Out	Liquid / Water In							
026-060	in.	21.0	26.1	57.3	54.0	52.3	0.7	58.1	27.4	28.3	26.8	24.3	15.9	9.5	4.0	3.1	0.8	1.5	10.5	15.5
	cm.	53.4	66.3	145.6	137.2	132.7	1.8	147.4	69.6	71.8	68.1	61.7	40.4	24.0	10.2	7.9	2.0	3.9	26.7	39.4

S	T	U	V	W	X	Y	Z	AA	BB	CC	DD	EE	FF	GG	HH	II	JJ	KK	LL	MM
15.5	18.0	19.5	20.1	59.5	15.1	53.1	51.3	7.8	4.9	1.5	18.0	1.5	18.0	2.0	2.0	2.0	22.1	2.0	16.9	1.96
39.4	45.8	49.5	51.0	151.1	38.4	134.9	130.2	19.8	12.5	3.8	45.7	3.8	45.7	5.1	5.1	5.1	56.2	5.0	42.9	5.0

Condensate is stainless steel 3/4" O.D
 Discharge flange is field installed and extends 1" (25.4 mm) from cabinet

Rev: 8/15/14

Unit Start Up

- **Check that supply voltage matches nameplate data.**
- **Fuses, breakers and wire size are correct.**
- **Confirm that the 15kW or 20kW auxiliary heat kit is wired correctly (see "Electrical Data" section if applicable).**
- **Low voltage wiring is complete.**
- Piping is complete and water system is cleaned and flushed.
- Air is purged from the closed loop system.
- Isolation valves are open, water control valves or pumps are wired.
- Condensate line is open and correctly pitched.
- Transformer switched to 208v if applicable.
- DIP switches are set correctly.
- Blower rotates freely.
- Blower speed is correct.
- Air filter/cleaner is clean and in position.
- Service/access panels are in place.
- Return air temperature is between 50-80°F heating and 60-95° cooling.
- Check air coil cleanliness to insure optimum performance. Clean as needed according to maintenance guidelines. To obtain maximum performance the air coil should be cleaned before startup. A 10 percent solution of dishwasher detergent and water is recommended for both sides of coil. A thorough water rinse should follow.

Maintenance Filters

Filters must be clean to obtain maximum performance. They should be inspected monthly under normal operating conditions and be replaced when necessary. Units should never be operated without a filter. Always replace the filter with the same type as originally furnished.

Condensate Drain

In areas where airborne bacteria produce slime in the drain pan, it may be necessary to treat chemically to minimize the problem. The condensate drain can pick up lint and dirt, especially with dirty filters.

Blower Motors

The ECM motor is equipped with sealed ball bearings and requires no periodic lubrication.

Air Coil

The air coil must be cleaned to obtain maximum performance. Check once a year under normal operating conditions and, if dirty, brush or vacuum clean. Care must be taken not to damage the aluminum fins while cleaning.

Caution: Fin edges are sharp.

Replacement Procedures

Obtaining Parts

When ordering service or replacement parts, refer to the model number and serial number of the unit as stamped on the serial plate attached to the unit. If replacement parts are required, mention the date of installation of the unit and the date of failure, along with an explanation of the malfunctions and a description of the replacement parts required.

In Warranty Material Return

Material may not be returned except by permission of authorized warranty personnel. Contact your local distributor for warranty return authorization and assistance.

Service Parts

Part Description		DX Refrigerant Models							Hydronic Models			
		022****R	026****R	030****R	036****R	042****R	048****R	060****R	026****H	036****H	048****H	060****H
Refrigeration	Air Coil	61S641-02				61S640-02			61S642-02			
	TXV	33P609-01			33P609-03	33P609-05		33P609-06	N/A			
ECM Motor & Blower	Blower Assembly	54S555-01	54S555-02	54S555-03	54S555-04	54S556-01	54S556-02	54S556-03	54S555-01	54S555-02	54S556-02	54S556-03
	ECM Blower Housing	53P501B01							53P501B01			
	ECM Motor 208-230/60/1	14S555-01	14S555-02	14S555-03	14S555-04	14S556-01	14S556-02	14S556-03	14S555-02	14S555-04	14S556-02	14S556-03
	ECM Power Harness	11P585B01							11P585B01			
	ECM Control Harness	11P598-01							11P598-01			
Electrical	Control board	17P551-01							17P551-01			
	Transformer	15P501B01							15P501B01			
	Power Block	12P501A02							12P501A02			
	Ground Lug	12P004A							12P004A			
Filter	Air Filter 20" x 24" x 1"	59P020B14							59P020B14			

08/14/14

Revision Guide

Pages:	Description:	Date:	By:
16-19, 26	Updated Wiring Schematics, Unit Start Up	01 April 2015	MA
5-7, 22-24	Updated Hydronic Data	15 Aug 2014	MA
4-6,19,20	Updated Drain Pan	20 May 2014	DS/MA
All	Updated Dimensional Data for New Vertical Condensate Drain	02 May 2014	DS
All	Updated Nomenclature For New ECM Motor	20 Feb 2013	DS
22	Added Service Parts List	20 Feb 2013	DS
23	Added Revision Guide	20 Feb 2013	DS



Product: **Aston Series Air Handler**
Type: Hydronic or R-410A
Size: 2 - 5 Tons

Document Type: Installation Manual
Part Number: IM1008HG
Release Date: 07/15