

G Series

Geothermal/Water Source Outdoor Split Heat Pump

- R-410A Refrigerant
- 2, 3, 4, 5, 6 Tons Dual Capacity

Installation Information

Water Piping Connections

Electrical

Startup Procedures

Troubleshooting

Preventive Maintenance



Table of Contents

Model Nomenclature	4
General Installation Information	5-7
Water Quality	8
Water Piping	9
Electrical Data	10
Thermostat Wiring	10
Dimensional Data	11
Physical Data	11
Model Nomenclature - Air Handler	12
Coil Data - Air Handler	12
Air Handler Compatibility	12
Physical Data - Air Handler	13
Model Nomenclature - Coil	13
Refrigerant Coil Compatibility	13
Wiring Schematics	14-17
Microprocessor Control	18-20
DIP Switch Settings	21
Refrigeration	22-23
Line Set Sizes	23
Pressure/Temperature Conversion Chart for R-410A	24
Operating Parameters	25
Pressure Drop	26
Compressor and Thermistor Resistance	26
Refrigerant Circuit Guideline	27
Heat of Extraction/Rejection Data	27
Reference Calculations	28
Legend	28
Operating Limits	28
Startup and Troubleshooting	29-31
Preventive Maintenance	32
Replacement Procedures	32
Service Parts List	33

Model Nomenclature

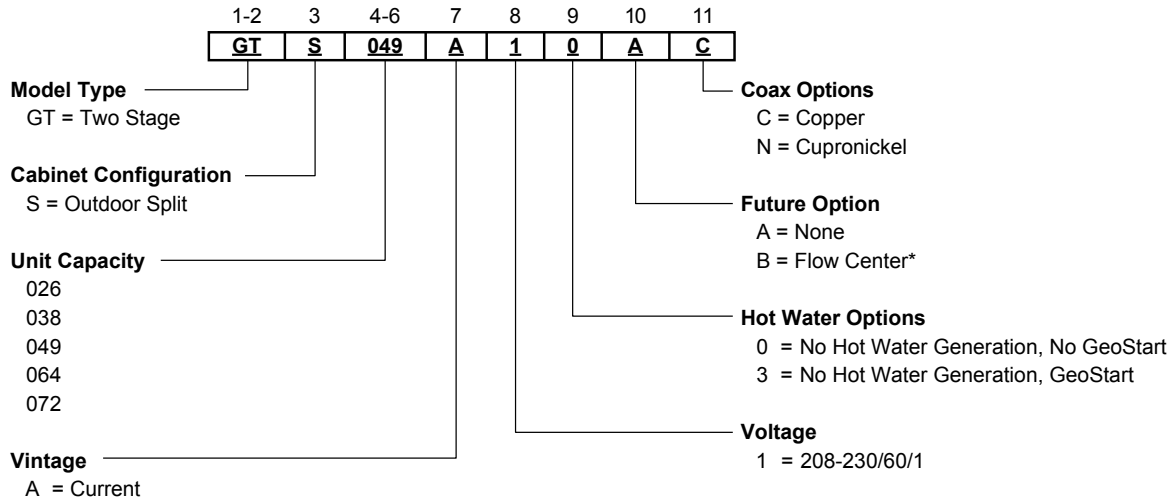

NOTE: * 026-049 uses the FC1-GL and 060-072 uses the FC2-GL

General Installation Information

Safety Considerations



WARNING: Before performing service or maintenance operations on a system, turn off main power switches to both units. Turn off accessory heater power switch if applicable. Electrical shock could cause personal injury. Installing and servicing heating and air conditioning equipment can be hazardous due to system pressure and electrical components. Only trained and qualified service personnel should install, repair or service heating and air conditioning equipment.

Installing and servicing heating and air conditioning equipment can be hazardous due to system pressure and electrical components. Only trained and qualified service personnel should install, repair or service heating and air conditioning equipment. Untrained personnel can perform the basic maintenance functions of cleaning coils and cleaning and replacing filters. All other operations should be performed by trained service personnel. When working on heating and air conditioning equipment, observe precautions in the literature, tags and labels attached to the unit and other safety precautions that may apply, such as the following safety measures:

- Follow all safety codes.
- Wear safety glasses and work gloves.
- Use a quenching cloth for brazing operations.
- Have a fire extinguisher available for all brazing operations.

Moving and Storage

Move units in the normal “up” orientation. Units may be moved and stored per the information on the packaging. Do not stack more than three units in total height. Do not attempt to move units while stacked. When the equipment is received, all items should be carefully checked against the bill of lading to be sure all crates and cartons have been received. Examine units for shipping damage, removing the units from the packaging if necessary. Units in question should also be internally inspected. If any damage is noted, the carrier should make the proper notation on the delivery receipt, acknowledging the damage.

Split Unit Location

Locate the split compressor section away from areas that may disturb the customer and in a way that allows easy removal of the access panels and the top of the cabinet. Provide sufficient room to make water, electrical and refrigerant line connections and allow space for service personnel to perform maintenance. The G Series split is approved for outdoor installation when properly installed.

Air Coil Location

Refer to the air handler manufacturer’s instructions for the blower coil unit for details on installing the air handling portion of the system.

Condensate Drain

Follow the blower coil manufacturer’s instructions.

Duct System

All blower coil units/air coils must be installed as specified by the manufacturer’s installation instructions; however, the following recommendations should be considered to minimize noise and service problems.

An air filter must always be installed upstream of the air coil on the return air side of the air handler or furnace. If there is limited access to the filter rack for normal maintenance, it is suggested that a return air filter grill be installed. Be sure that the return duct is properly installed and free of leaks to prevent dirt and debris from bypassing the filter and plugging the air coil.

In applications using galvanized metal ductwork, a flexible duct connector is recommended on both the supply and return air plenums to minimize vibration from the blower. To maximize sound attenuation of the unit blower, the supply and return plenums should include an internal duct liner of 1-inch thick glass fiber or be constructed of ductboard. Insulation is usually not installed in the supply branch ducts. Ducts in unconditioned areas should be wrapped with a minimum of 1-inch duct insulation. Application of the unit to uninsulated ductwork in an unconditioned space is not recommended as the unit’s performance will be adversely affected. If the air handler is connected to existing ductwork, a previous check should have been made to assure that the duct system has the capacity to handle the air required for the unit application. If ducting is too small, as in replacement of heating only systems, larger ductwork should be installed. All existing ductwork should be checked for leaks and repairs made accordingly. The duct systems and diffusers should be sized to handle the design airflow quietly. If air noise or excessive airflow is a problem, the blower speed can be changed to a lower speed to reduce airflow. This will reduce the performance of the unit slightly in heating; however, it will increase the temperature rise across the air coil. Airflow must still meet minimum requirements.

Equipment Selection

The following guidelines should be used when mating a G Series Split to an air handler/coil.

- Select R-410A components only.
- Match the air handler to the air handler coil data table.
- Indoor matching adjustable TXV is factory installed on every GAH air handler/coil. Fixed orifice or cap tube systems should not be used.
- Minimum of two (2) blower speeds

General Installation Information cont.

Utilizing Existing Coil or Air Handler

It is recommended that a new R-410A air handler be installed with a G Series Split considering the long term benefits of reliability, warranty, etc. versus the short term installation cost savings.

However, the existing air handler may be retained provided the following:

- Coil currently is R-410A rated
- Coil uses a TXV. No capillary or fixed orifice systems should be used
- A life expectancy of more than 7 years remaining for the air handler and components
- Flush air coil and line set

When utilizing the existing air coil or line set, only flushing compounds that vaporize should be used; which means they are packaged in a pressurized disposable cylinder. It is preferable to use a flushing agent that removes oil, water, and acid, plus, is biodegradable and non-toxic. The flushing agent should be safe to use with both HCFC and HFC refrigerants. Once a flushing agent has been selected, follow the instructions provided with the product.

The first step should be purging the lines or air coil with nitrogen. Purging with nitrogen first will remove some of the particulate and residual oil which will allow the flushing agent to work better. Never blow the flushing agent through a compressor, filter drier, or txv as it will cause the components to fail.

When flushing is complete and the final system is assembled, an acid check should be performed on the system. Acid test kits are available from most HVACR distributors.

Connection to Air Coil

Typical Split System Application - Remote Blower Coil and Typical Split System Heat Pump Coil Add-on Fossil Fuel Furnace illustrations show typical G Series Split installations. The Line Set Sizes table shows typical line set diameters and maximum length. Line sets over 60 feet are not recommended. If the line set is kinked or deformed and cannot be reformed, the bad section of pipe should be replaced. A restricted line set will affect unit performance.

As in all R-410A equipment, a reversible liquid line filter drier is required to ensure all moisture is removed from the system. This drier should be replaced whenever "breaking into" the system for service. All line sets should be insulated with a minimum of 1/2" closed cell insulation. All exterior insulation should be painted with UV resistant paint or covering to ensure long insulation life.

Air Handler Installation

Air handlers used with dual capacity units must be capable of operating with a minimum of 2 blower speeds. Refer to the manufacturer's instructions for the blower coil unit for details on installing the air handling portion of the system. All blower coil units/air coils must be installed as specified by the manufacturer's installations instructions. However, the following recommendations should be considered to minimize noise and service problems.

An air filter must always be installed upstream of the air coil on the return air side of the air handler or furnace. If there is limited access to the filter rack for normal maintenance, it is suggested that a return air filter grille be installed. Be sure that the return duct is properly installed and free of leaks to prevent dirt and debris from bypassing the filter and plugging the air coil.

Ensure that the line set size is appropriate to the capacity of the unit (refer to Line Set Sizes table). Line sets should be routed as directly as possible, avoiding unnecessary bends or turns. All wall penetrations should be sealed properly. Line set should not come into direct contact with water pipes, floor joists, wall studs, duct work, floors, walls and brick. Line set should not be suspended from joists or studs with a rigid wire or strap which comes into direct contact with the tubing. Wide hanger strips which conform to the shape of the tubing are recommended. Isolate hanger straps from line set insulation by using metal sleeves bent to conform to the shape of insulation. Line set insulation should be pliable, and should completely surround the refrigerant line.

NOTE: Improper installation of equipment may result in undesirable noise levels in the living areas.

Typical Split System Application - Remote Blower Coil

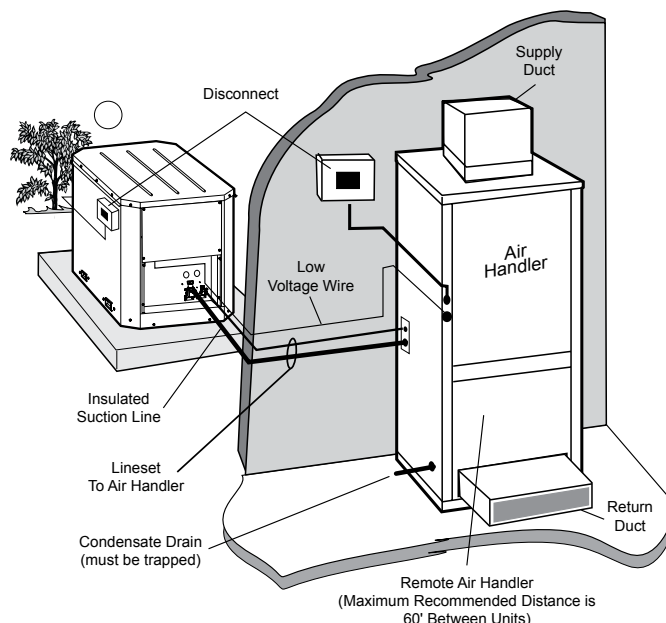

General Installation Information cont.

Dual Fuel Systems

G Series units can be connected to fossil fuel furnaces that include an A-coil or slab coil. Dual fuel installations utilize the G Series heat pump for heating until the point that auxiliary heat is called for on the thermostat. At that point, the furnace will be enabled and the heat pump will be disabled. The G Series heat pump provides air conditioning through the furnace's refrigerant coils.

Refer to the furnace manufacturer's installation manual for the furnace installation, wiring and coil insertion. A Dual Fuel thermostat or a field-installed DPST relay is required. See the Typical Split System Heat Pump Coil Add-on Fossil Fuel Furnace illustration for typical Dual Fuel application.

In add-on G Series Split applications, the coil should be located in the supply side of the furnace to avoid condensation damage to the furnace heat exchanger. A high temperature limit should be installed upstream of the coil to de-energize the compressor whenever the furnace is operating. Without this switch, the G Series Split will trip out on high pressure. A dual fuel thermostat can remove the Y1 and Y2 calls when a W call is energized to allow gas furnace backup on an G Series Split application. Refer to the Thermostat Wiring section for details.

Typical Split System Heat Pump Coil Add-on Fossil Fuel Furnace

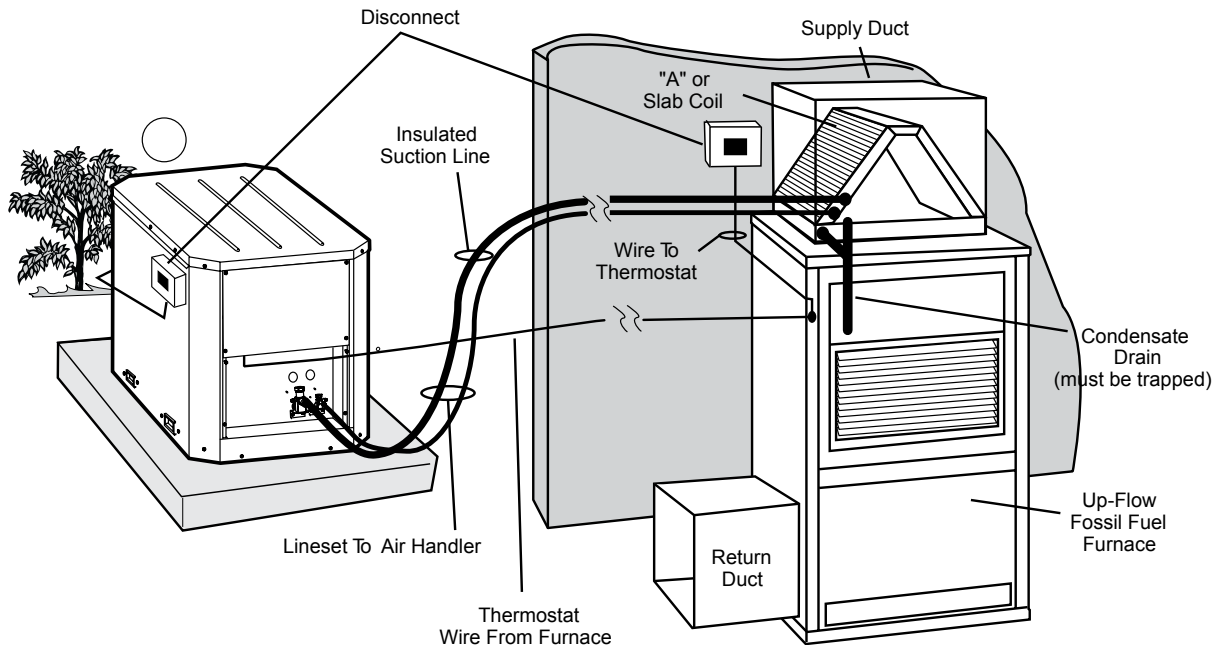

Water Quality

In ground water situations where scaling could be heavy or where biological growth such as iron bacteria will be present, a closed loop system is recommended. The heat exchanger coils in ground water systems may, over a period of time, lose heat exchange capabilities due to a buildup of mineral deposits inside. These can be cleaned, but only by a qualified service mechanic, as special solutions and pumping equipment are required. Hot water generator coils can likewise become scaled and possibly plugged.

In areas with extremely hard water, the owner should be informed that the heat exchanger may require occasional flushing. Failure to adhere to the guidelines in the water quality table could result in loss of warranty.

Units with cupronickel heat exchangers are recommended for open loop applications due to the increased resistance to build-up and corrosion, along with reduced wear caused by acid cleaning.

Material		Copper	90/10 Cupro-Nickel	316 Stainless Steel
pH	Acidity/Alkalinity	7 - 9	7 - 9	7 - 9
Scaling	Calcium and Magnesium Carbonate	(Total Hardness) less than 350 ppm	(Total Hardness) less than 350 ppm	(Total Hardness) less than 350 ppm
Corrosion	Hydrogen Sulfide	Less than .5 ppm (rotten egg smell appears at 0.5 PPM)	10 - 50 ppm	Less than 1 ppm
	Sulfates	Less than 125 ppm	Less than 125 ppm	Less than 200 ppm
	Chlorine	Less than .5 ppm	Less than .5 ppm	Less than .5 ppm
	Chlorides	Less than 20 ppm	Less than 125 ppm	Less than 300 ppm
	Carbon Dioxide	Less than 50 ppm	10 - 50 ppm	10- 50 ppm
	Ammonia	Less than 2 ppm	Less than 2 ppm	Less than 20 ppm
	Ammonia Chloride	Less than .5 ppm	Less than .5 ppm	Less than .5 ppm
	Ammonia Nitrate	Less than .5 ppm	Less than .5 ppm	Less than .5 ppm
	Ammonia Hydroxide	Less than .5 ppm	Less than .5 ppm	Less than .5 ppm
	Ammonia Sulfate	Less than .5 ppm	Less than .5 ppm	Less than .5 ppm
Iron Fouling (Biological Growth)	Total Dissolved Solids (TDS)	Less than 1000 ppm	1000-1500 ppm	1000-1500 ppm
	LSI Index	.05 to .05	.05 to .05	.05 to .05
Iron Fouling (Biological Growth)	Iron, Fe ²⁺ (Ferrous) Bacterial Iron Potential	< .2ppm	< .2 ppm	< .2 ppm
	Iron Oxide	Less than 1 ppm. Above this level deposition will occur.	Less than 1 ppm. Above this level deposition will occur.	Less than 1 ppm. Above this level deposition will occur.
Erosion	Suspended Solids	Less than 10 ppm and filtered for max of 600 micron size	Less than 10 ppm and filtered for max of 600 micron size	Less than 10 ppm and filtered for max of 600 micron size
	Threshold Velocity (Fresh Water)	< 6 ft/sec	< 6 ft/sec	< 6 ft/sec

Note:
Grains = PPM divided by 17
mg/l is equivalent to PPM

Water Piping

Residential G Series Outdoor Split units are supplied standard with GeoLink swivel connections with P.T. ports.



CAUTION: Water piping exposed to outside temperatures may be subject to freezing.

Water Piping

The proper water flow must be provided to each unit whenever the unit operates. To assure proper flow, use pressure/temperature ports to determine the flow rate. These ports should be located at the supply and return water connections on the unit. The proper flow rate cannot be accurately set without measuring the water pressure drop through the refrigerant-to-water heat exchanger.

Closed Loop - Earth coupled Systems (Outdoor Installations)

Locate unit on an air pad with access hole as shown below. When mounting on an existing concrete pad, holes must be bored through to accommodate 1 1/4-inch P.E. pipe with 1/2-inch insulation.

Connecting To Earth Loop

The earth loop trench should be continued directly under the unit as shown in the Typical Split System Outdoor Installation Using Closed Loop. Make the connections to optional fittings from the loop circulator pump(s) and ensure proper backfill to support the loop pipe during trench settling. All 1 1/4-inch piping should be insulated with a minimum of 1/2-inch closed cell insulation from below the ground surface to the loop circulator.



IMPORTANT: A freeze detection thermostat is installed in the unit to automatically start loop circulator pump if loop temperature drops below 20°F. Loop freeze detection should also be maintained to the lowest temperature the insulated loop may encounter in the case of power failure.

Open Loop (Indoor Installations)

G Series Outdoor Splits can be installed on an open loop system, but only indoors. All G Series Outdoor Splits are supplied with GeoLink swivel connectors. The swivel connectors will also accept 1 in O.D. copper pipe (sweat); which can be connected in an open loop system.

Flow Center Installation

Flow centers FC1-GL or FC2-GL, as needed, may be internally mounted on the G Series Outdoor Splits. Two stub tubes with barbs are pre connected to the coax. Two tubes with brass fittings, to adapt to the flow center, 2 hoses to connect between the two sets of tubes, and four hose clamps are included with each G Series Outdoor Split unit. The brass adapter fittings have plastic swivel connectors that also accept 1 in. O.D. copper pipe (sweat).

NOTE: For ease of installation, attach provided hoses to coax first and then trim to fit to elbows on flow center.

Typical Split System Outdoor Installation Using Closed Loop

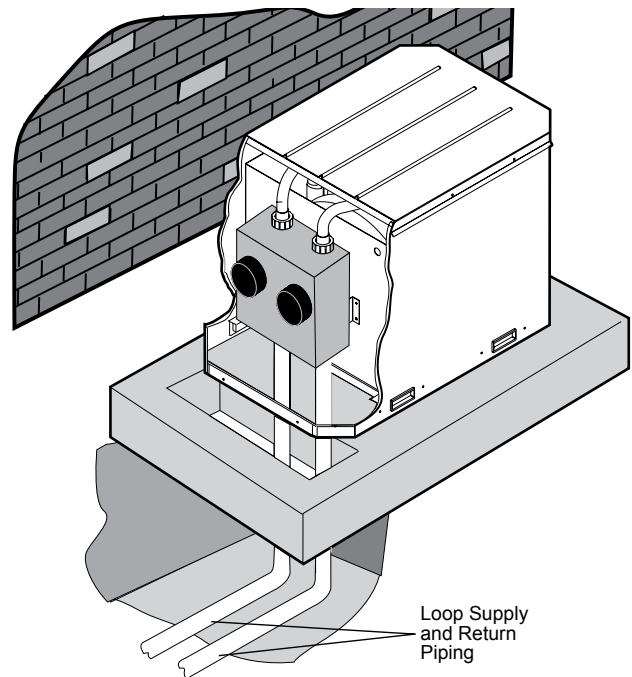

Electrical Data

General

Be sure the available power is the same voltage and phase as that shown on the unit serial plate. Line and low voltage wiring must be done in accordance with local codes or the National Electric Code, whichever is applicable. See unit electrical data for fuse or circuit breaker sizing information.

Model	Rated Voltage	Voltage Min/Max	Compressor				Ext Loop FLA	Total Unit FLA	Min Circ Amp	Max Fuse/HACR
			MCC	RLA	LRA	LRA*				
026	208-230/60/1	197/253	16.0	10.2	52.0	18.0	5.4	15.6	17.0	25
038	208-230/60/1	197/253	26.0	16.6	82.0	29.0	5.4	22.0	23.4	40
049	208-230/60/1	197/253	33.0	21.1	96.0	34.0	5.4	26.5	27.9	50
064	208-230/60/1	197/253	40.0	25.6	118.0	41.0	5.4	31.0	32.4	60
072	208-230/60/1	197/253	42.5	27.2	150.0	53.0	5.4	32.6	34.0	60

Rated voltage of 208-230/60/1.
 HACR circuit breaker in USA only.
 Min/Max voltage of 197/253.
 All fuses Class RK-5
 * With optional GeoStart

01/17/11

Thermostat Wiring

Thermostat Wiring

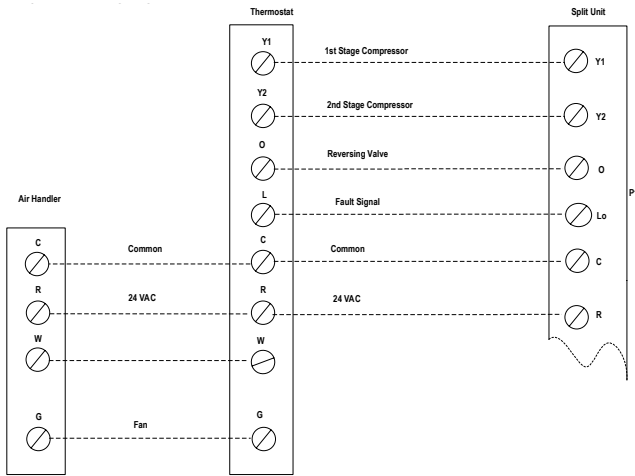

Air Handler transformer must be at least 75 VA.

Thermostat Wiring for Dual Fuel Applications

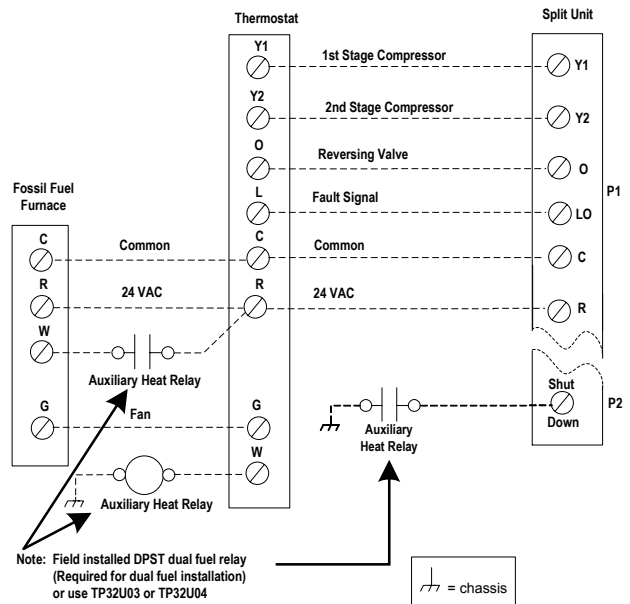

Note: Field installed DPST dual fuel relay (Required for dual fuel installation) or use TP32U03 or TP32U04

⏏ = chassis

Dimensional Data

Cabinet Dimensions and Refrigerant Piping Connections

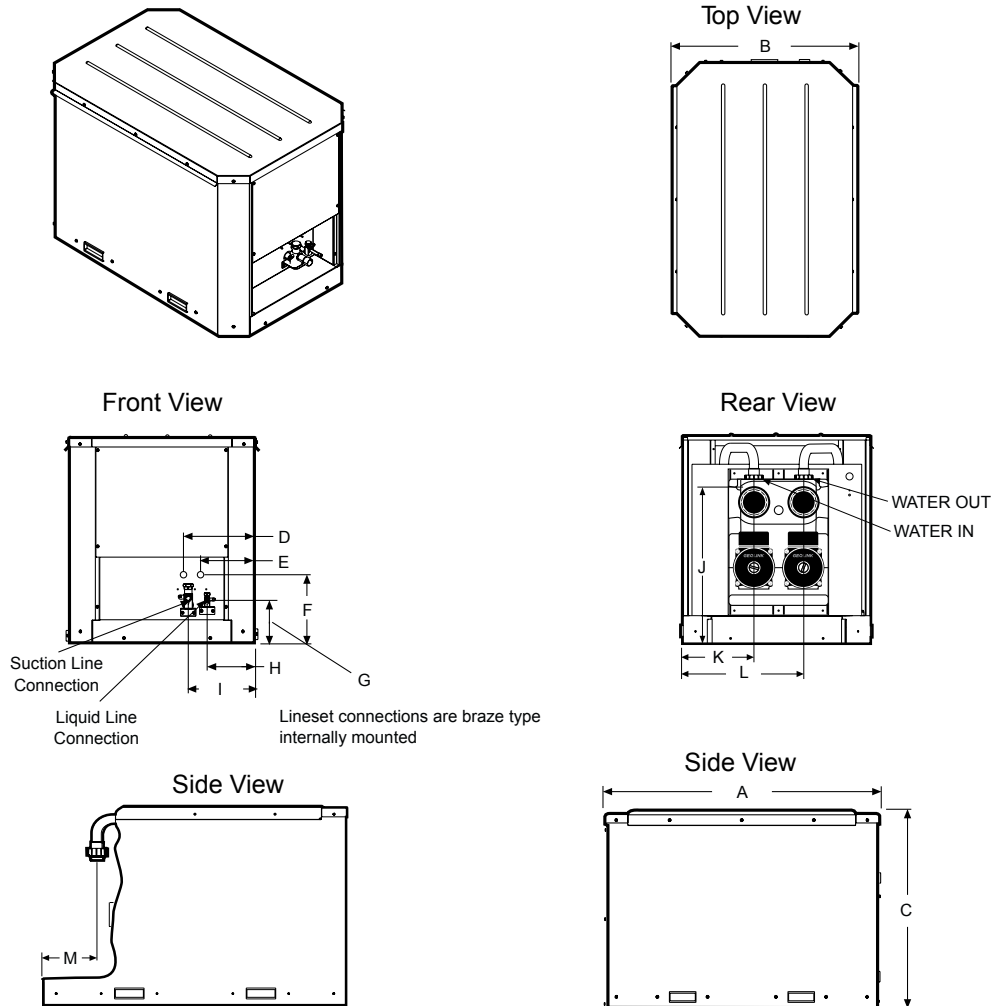

Model		A	B	C	D	E	F	G	H	I	J	K	L	M
026 thru 072	in	36.0	23.9	26.7	9.3	7.1	9.0	5.6	8.2	10.7	18.9	8.7	14.8	7.0
	[cm]	[91.4]	[60.7]	[67.8]	[23.7]	[18.0]	[22.8]	[14.2]	[20.9]	[27.2]	[48.0]	[22.1]	[37.6]	[17.8]

NOTES: Refer to Physical Dimensions and Piping Connections drawings
Inches [cm]

Physical Data

Model	026	038	049	064	072
Compressor (1 each)	Dual Capacity Scroll				
Factory Charge R-410A, oz [kg]	52 [1.47]	56 [1.59]	90 [2.55]	92 [2.61]	104 [2.95]
Coax and Water Piping					
Water Connections Size - Swivel- in [mm]	GeoLink Swivel Connectors				
Brass Service Valve - Liquid Line - in [mm]	3/8 [9.525]			1/2 [12.7]	
Brass Service Valve - Suction Line - in [mm]	5/8 [15.875]	3/4 [19.05]		7/8 [22.225]	
Coax and Piping Water Volume - gal [l]	0.7 [2.6]	1.3 [4.9]	1.6 [6.1]	1.6 [6.1]	1.6 [6.1]
Weight - Operating, lb [kg]	189 [86]	236 [107]	250 [113]	271 [123]	290 [132]
Weight - Packaged, lb [kg]	209 [95]	256 [116]	270 [122]	291 [132]	310 [141]

All units have TXV expansion devices, and 1/2 in. [12.2 mm] and 3/4 in. [19.1 mm] electrical knockouts.
Brass service valves are sweat type valves.

10/29/08

Model Nomenclature - Air Handler

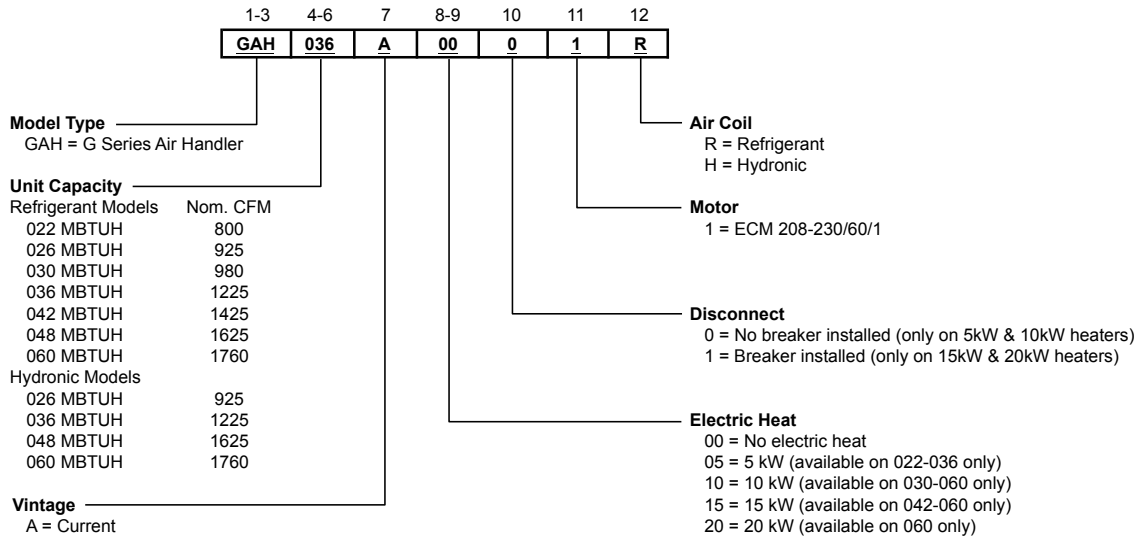

NOTE: Kit GAHBC must be ordered to field convert the GAH042-060 to bottomflow air discharge.

Coil Data - Air Handler

G Series Outdoor Split Model	Matching Air Handler	Coil Surface Area (ft ²)	FPI	Rows	Tube Diameter
022 - 038	GAH036	5.83	12	2	3/8 in.
042 - 072	GAH060	5.83	12	3	3/8 in.

Air Handler Compatibility

Air Handler	Indoor Split Model (Single)	Indoor Split Model (Dual Capacity)	Outdoor Split Model (Dual Capacity)	Airflow (CFM)	Electric Heat (kW)
GAH022A****R	GSZ022	-	-	800	5
GAH026A****R	-	GTZ026	GTS026	925	5
GAH030A****R	GSZ030	-	-	980	5, 10
GAH036A****R	GSZ036	-	-	1225	5, 10
GAH036A****R	-	GTZ038	GTS038	1225	5, 10
GAH042A****R	GSZ042	-	-	1425	10, 15
GAH048A****R	GSZ048	-	-	1625	10, 15
GAH048A****R	-	GTZ049	GTS049	1625	10, 15
GAH060A****R	GSZ060	-	-	1760	10, 15, 20
GAH060A****R	-	GTZ064	GTS064	1760	10, 15, 20
GAH060A****R	GSZ070	-	-	1760	10, 15, 20
GAH060A****R	-	GTZ072	GTS072	1760	10, 15, 20

Physical Data - Air Handler

Air Handler Model Number (Refrigerant)		GAH022	GAH026	GAH030	GAH036	GAH042	GAH048	GAH060	
Evaporator Coil	Air Coil Total Face Area, ft2 [m2]	5.83 [0.54]							
	Tube outside diameter - in. [mm]	3/8 [9.52]							
	Number of rows	2			3				
	Fins per inch	12							
	Suction line connection - in. [mm] sweat	5/8 [15.87]				7/8 [22.22]			
	Liquid line connection - in. [mm] sweat	3/8 [9.52]							
Refrigerant		R-410a							
Nominal cooling capacity - tons [kW]		1.8 [6.44]	2.1 [7.59]	2.5 [8.79]	3 [10.55]	3.5 [12.30]	4 [14.06]	5 [17.58]	
Condensate drain connection - (FPT) in. [mm]		3/4 [19.05]							
Blower Wheel Size (Dia x W), in. [mm]		11 x 10 [279 x 254]							
Blower motor type/speeds		ECM variable speed							
Blower motor output - hp [W]		1/2 [373]				1 [746]			
Filter Standard - 1" [51mm] MERV3 disposable, in. [mm]		20 x 24 [508 x 635]							
Electrical characteristics (60hz)		208/230 - 1ph							
Shipping weight - lbs. [kg]		215 [97.52]				220 [99.79]			
Operating weight - lbs. [kg]		195 [88.45]				200 [90.71]			

1/11/08

Model Nomenclature - Coil

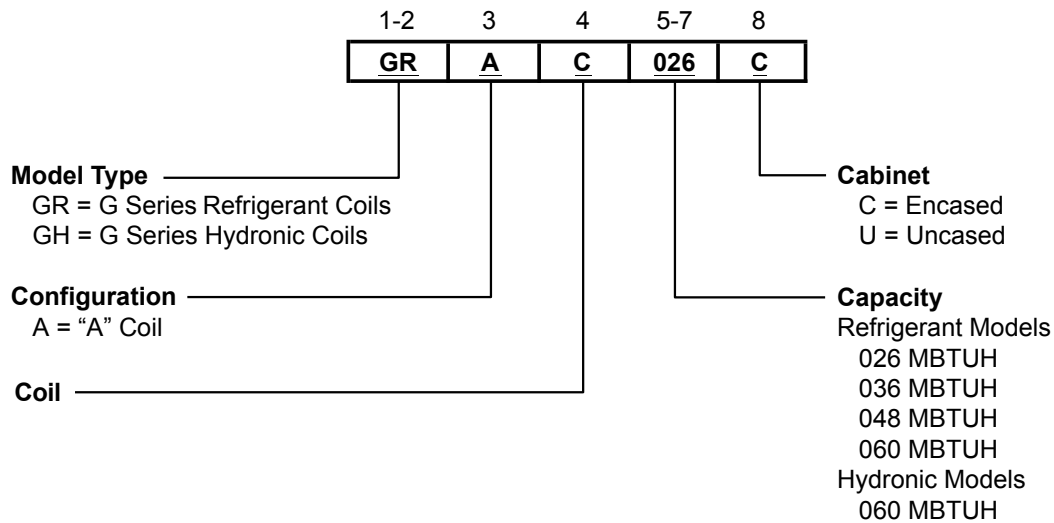

Refrigerant Coil Compatibility

Encased/Uncased Coil	Indoor Split Model (Single)	Indoor Split Model (Dual Capacity)	Outdoor Split Model (Dual Capacity)	Recommended Airflow (CFM)
GRAC026*	GSZ022	-	-	800
GRAC026*	-	GTZ026	GTS026	925
GRAC026*	GSZ030	-	-	980
GRAC036*	GSZ036	-	-	1225
GRAC036*	-	GTZ038	GTS038	1225
GRAC048*	GSZ042	-	-	1425
GRAC048*	GSZ048	-	-	1625
GRAC048*	-	GTZ049	GTS049	1625
GRAC060*	GSZ060	-	-	1760
GRAC060*	-	GTZ064	GTS064	1760
GRAC060*	GSZ070	-	-	1760
GRAC060*	-	GTZ072	GTS072	1760

7/14/08

Wiring Schematics

Dual Capacity Split - 208-230/60/1

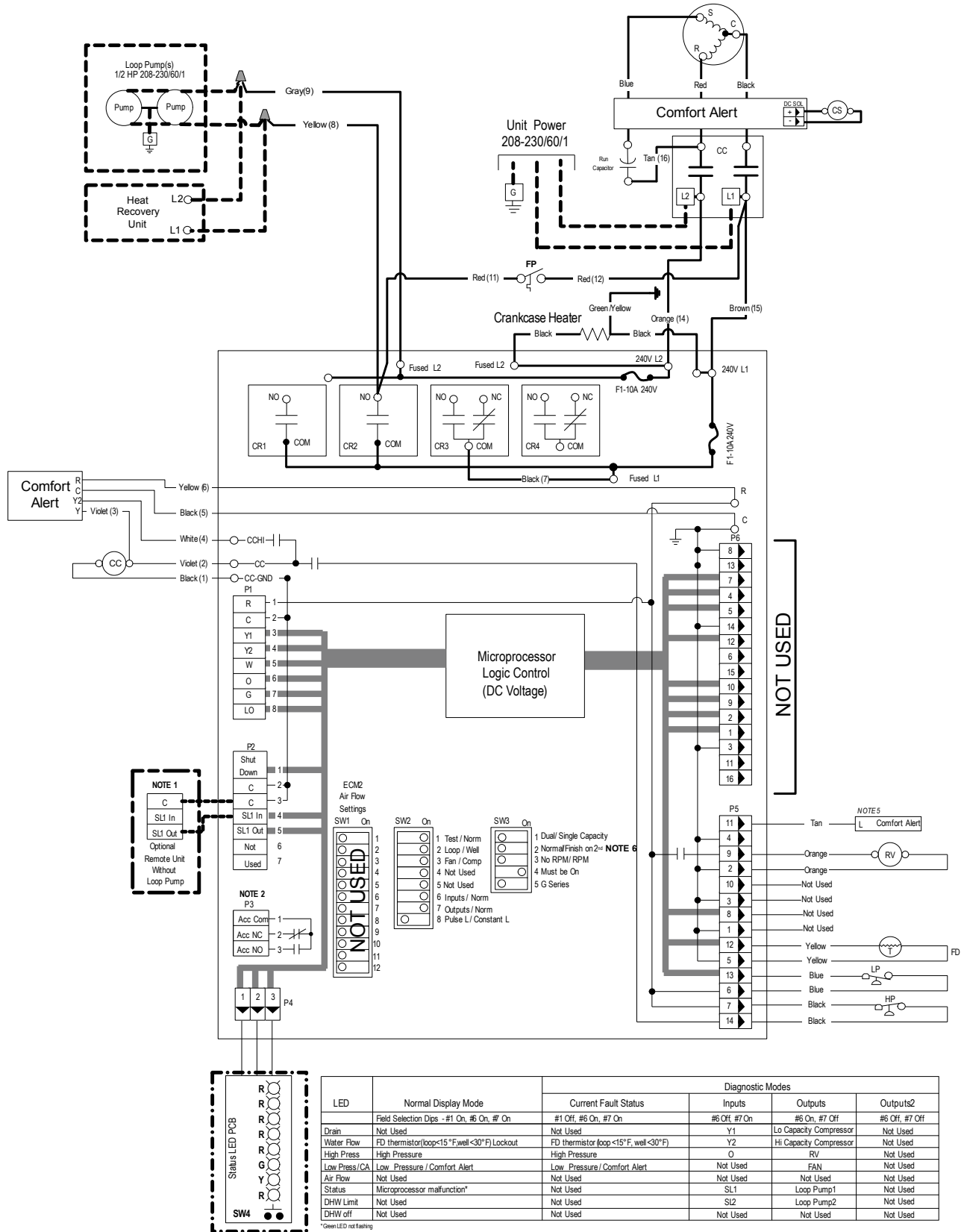

Wiring Schematics cont.

Dual Capacity Split - 208-230/60/1 cont.

Notes

- 1 - Connection of remote unit that does not have a loop pump for slave operation.
- 2 - 24V Accessory relay (see SW2 -3 for description of operation)
- 3 - Field installed DPDT dual fuel relay. (Required for dual fuel installation)
- 4 - DHW pump only in models with hot water generation option.
- 5 - Comfort Alert fault output to Premier Control Board
- 6 - This Switch allows the unit to down stage with the t-stat when OFF and finish on second stage when ON. Finish second stage reduces stage changing in recip dual capacity compressors and should be ON for unzoned Dual Cap G Series 2 speed units.

Legend

- Factory Low voltage wiring
- Factory Line voltage wiring
- Field low voltage wiring
- Field line voltage wiring
- Optional block
- DC Voltage PCB traces
- Internal junction
- Quick connect terminal
- Wire nut
- Field wire lug
- Ground
- Relay Contacts - N.O., N.C.
- Fuse

- CA- Comfort Alert
- CS- Compressor Solenoid
- CC- Compressor Contactor
- CR1 - Not Used
- CR2- Loop Pump Relay1
- CR3 - Loop Pump Relay2
- CR4 - Not Used
- F1 and F2- Fuses
- FD- Freeze Detection sensor
- HP- High Pressure Switch
- LP- Low Pressure Switch
- RV- Reversing Valve Coil
- SW1 - Not Used
- SW2 - DIP Package 8 Position
- SW3 - DIP Package 5 Position

- Crankcase Heater
- Thermistor
- Light Emitting Diode - Green
- Relay Coil
- Capacitor w/ Bleed Resistor
- Switch-High Pressure
- Switch-Low Pressure
- Polarized Connector

Logic Board - Physical Layout

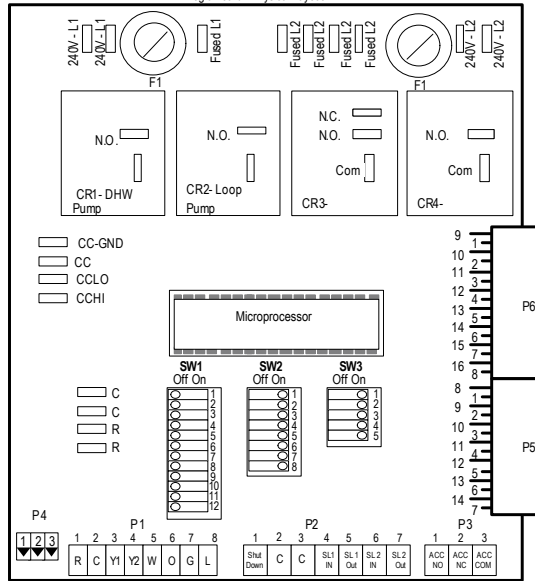

Comfort Alert Physical Layout

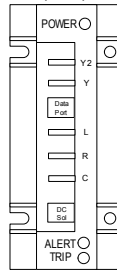

Comfort Alert Status		
LED	Flash Code	Description
Green	Solid	Module Has Power
Red	Solid	Y1 Present But Compressor Not Running
Yellow	Code 1	Long Run Time
	Code 2	System Pressure Trip
	Code 3	Short Cycling
	Code 4	Locked Rotor
	Code 5	Open Circuit
	Code 6	Open Start Circuit
	Code 7	Open Run Circuit
	Code 8	Welded Contactor
	Code 9	Low Voltage

Wiring Schematics cont.

Dual Capacity Split with GeoStart - 208-230/60/1

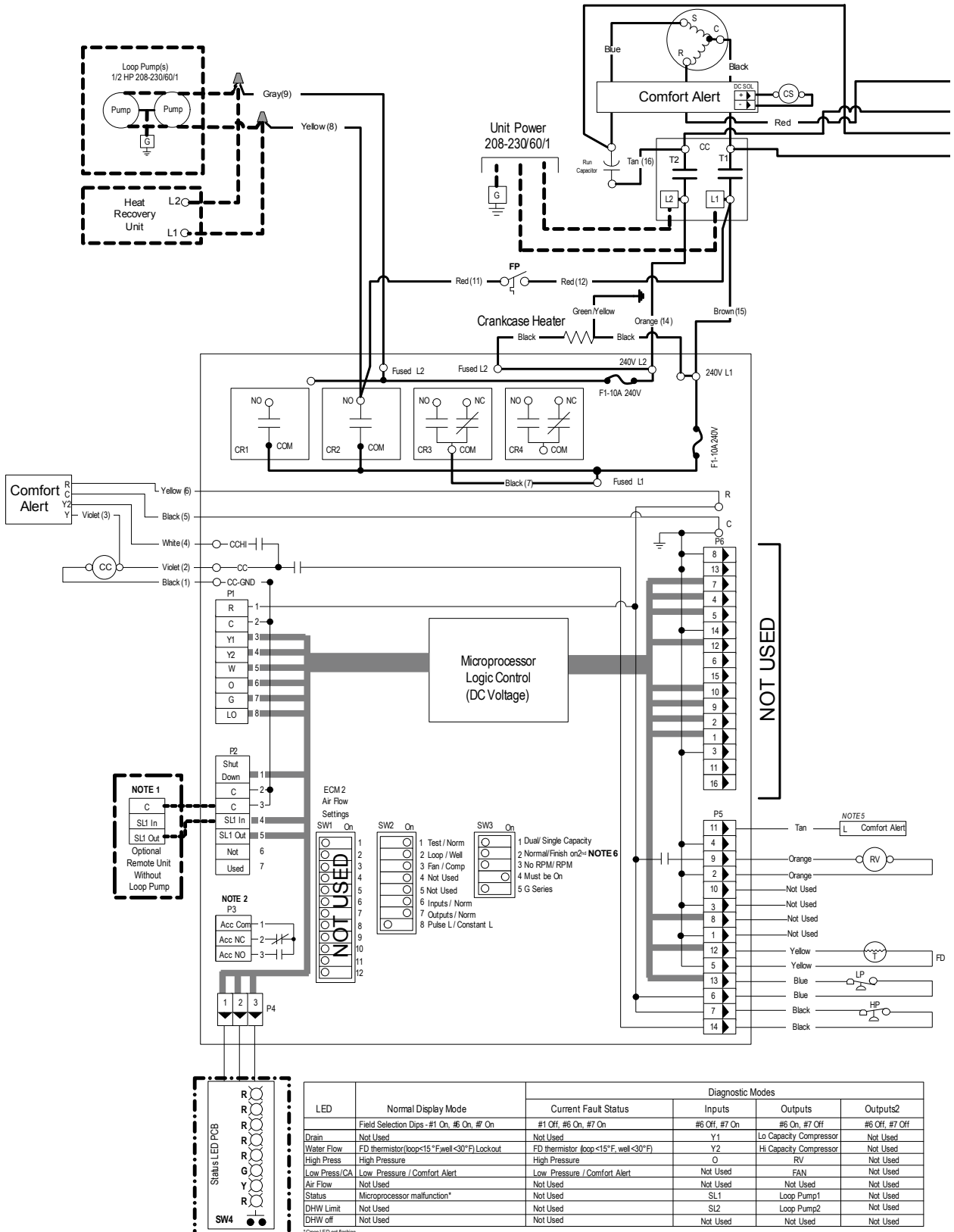

Wiring Schematics cont.

Dual Capacity Split with GeoStart - 208-230/60/1 cont.

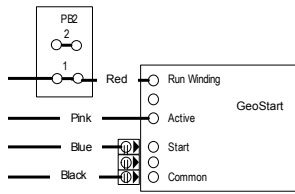

Legend

- Factory Low voltage wiring
- Factory Line voltage wiring
- Field low voltage wiring
- Field line voltage wiring
- Optional block
- DC Voltage PCB traces
- Internal junction
- Quick connect terminal
- Wire nut
- Field wire lug
- Ground
- Relay Contacts - N.O., N.C.
- Fuse

- CA- Comfort Alert
- CS- Compressor Solenoid
- CC- Compressor Contactor
- CR1- Not Used
- CR2- Loop Pump Relay 1
- CR3- Loop Pump Relay 2
- CR4- Not Used
- F1 and F2- Fuses
- FP- Freeze Detection sensor
- HP- High Pressure Switch
- LP- Low Pressure Switch
- RV- Reversing Valve Coil
- SW1- Not Used
- SW2- DIP Package 8 Position
- SW3- DIP Package 5 Position

- Crankcase Heater
- Thermistor
- Light Emitting Diode-Green
- Relay Coil
- Capacitor w/ Bleed Resistor
- Switch-High Pressure
- Switch-Low Pressure
- Polarized Connector

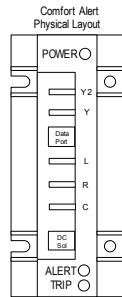
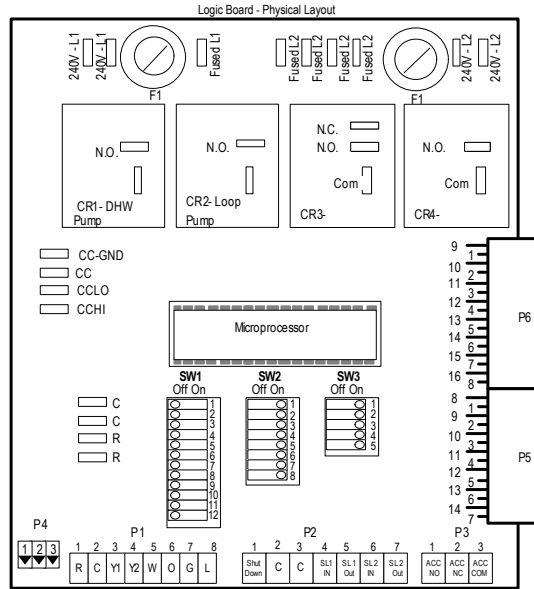

Comfort Alert Status		
LED	Flash Code	Description
Green	Solid	Module Has Power
Red	Solid	Y1 Present But Compressor Not Running
Yellow	Code 1	Long Run Time
	Code 2	System Pressure Trip
	Code 3	Short Cycling
	Code 4	Locked Rotor
	Code 5	Open Circuit
	Code 6	Open Start Circuit
	Code 7	Open Run Circuit
	Code 8	Welded Contactor
	Code 9	Low Voltage

- ### Notes
- 1 - Connection of remote unit that does not have a loop pump for slave operation.
 - 2 - 24V Accessory relay (see SW2 -3 for description of operation)
 - 3 - Field installed DPDT dual fuel relay. (Required for dual fuel installation)
 - 4 - DHW pump only in models with hot water generation option.
 - 5 - Comfort Alert fault output to Premier Control Board
 - 6 - This Switch allows the unit to down stage with the t-stat when OFF and finish on second stage when ON. Finish second stage reduces stage changing in recip dual capacity compressors and should be ON for unzoned Dual Cap G Series speed units.

Microprocessor Control

The GTS control system is a microprocessor-based printed circuit board conveniently located in the unit control box for easy accessibility. The microprocessor control is specifically designed for the GTS Series heat pumps. The microprocessor provides control of the entire unit as well as outputs for status modes, faults, and diagnostics. Low voltage terminal strips provide all necessary terminals for field connections. An LED board is installed for quick diagnostics. The control offers optimal space conditioning. The board accepts traditional 24VAC thermostat inputs.

Startup

The unit will not operate until all the inputs and safety controls are checked for normal conditions. At first power-up, a four-minute delay is employed before the compressor is energized.

Component Sequencing Delays

Components are sequenced and delayed for optimum space conditioning performance.

Accessory Relay

An accessory relay on the control board allows for field connection of solenoid valves, electronic air cleaners, etc. The accessory relay has a normally open output and a normally closed output. The accessory relay is factory set to control the optional electronic air-cleaner.

Short Cycle Protection

The control employs a minimum "off" time of four minutes and a minimum "on" time of two minutes to provide for short cycle protection of the compressor.

Loop Pump Slaving Signals

A signal between multiple GTS Series control boards at the slave inputs and outputs (SL1 In and Out) will provide for remote control of the loop pump on any unit.

Shutdown Input

A 24VAC common signal to the "shutdown" input on the control board puts the unit into shutdown mode. Compressor, hot water pump and fan operation are suspended.

Safety Controls

The GTS control receives separate signals for a high pressure switch for safety, a low pressure switch to prevent loss of charge damage, and a low suction temperature thermistor for freeze sensing. Upon a continuous 30-second measurement of the fault (immediate for high pressure), compressor operation is suspended (see Fault Retry), the appropriate lockout LED begins flashing, and an output signal (LO) is made available for connection to a "fault" LED at the thermostat.

Testing

The GTS control allows service personnel to shorten most timing delays for faster diagnostics.

Fault Retry

All faults are retried twice before finally locking the unit out. The "fault retry" feature is designed to prevent nuisance service calls.

Diagnostics

The GTS control board allows all inputs and outputs to be displayed on the LEDs for fast and simple control board diagnosis.

Heating Operation

Note: At first power up, a four-minute time delay is employed before the compressor is energized.

Heat, 1st Stage (Y1)

The compressor and loop pumps are energized 10 seconds after the Y1 input.

Heat, 2nd Stage (Y1,Y2) Dual Capacity Units

The second stage compressor will be activated 5 seconds after receiving a "Y2" input as long as the minimum first stage compressor run time of 1 minute has expired.

The Comfort Alert will delay the second stage compressor until 5 seconds after it receives "Y2" from the board.

Cooling Operation

In all cooling operations, the reversing valve directly tracks the "O" input. Thus, anytime the "O" input is present, the reversing valve will be energized.

Cool, 1st Stage (Y1, O)

The compressor and loop pumps are energized 10 seconds after the Y1 input.

Cool, 2nd Stage (Y1, Y2, O) Dual Capacity Units

The second stage compressor will be activated 5 seconds after receiving a "Y2" input as long as the minimum first stage compressor run time of 1 minute has expired.

The Comfort Alert will delay the second stage compressor until 5 seconds after it receives a "Y2" from the board.

Fan Only Operation

The Fan Only mode is controlled directly from the unit thermostat to the unit air handler. No input is given to the microprocessor to operate the fan function.

Lockout Conditions

During lockout mode, the appropriate thermostat lockout LEDs (if available) will illuminate. The compressor and loop pumps are de-energized and if the thermostat calls for third stage heating, emergency heat operation will occur.

Lockout modes of any kind can be reset at the thermostat after a 5-second waiting period, which restores normal operation.

Microprocessor Control cont.

High Pressure

This lockout mode occurs immediately when the normally closed safety switch is momentarily opened.

Low Pressure

This lockout mode occurs when the normally closed switch is opened for 30 continuous seconds.

Freeze Detection (Water Flow)

This lockout mode occurs when the freeze detection thermistor temperature (located between the TXV and coax) is at or below the selected freeze sensing point (well 30°F or loop 15°F) for 30 continuous seconds.

The unit also contains a secondary freeze detection sensor located on the entering water line of the unit. If the loop reaches a temperature of 20°F the secondary freeze detection sensor will cycle the loop pumps "on" until the loop temperature rises to or above 25°F.

Logic Board - Dual Capacity



Dual Capacity Operation Logic

OPERATION	HEATING			COOLING	
	STG1	STG2	STG3	STG1	STG2*
Compressor-Low	On	Off	Off	On	Off
Compressor-Hi	Off	On	Off	Off	On
Fan	On	On	On	On	On
Loop Pump	On	On	Off	On	On
Reversing Valve	Off	Off	Off	On	On
T-Stat Signal	Y1	Y1, Y2	W	Y1, O	Y1, Y2, O

Microprocessor Control cont.

Thermostat Displays

Fault Flash

When using a TA32W02 or TP32W03 thermostat and SW2-8 is in the pulsing "L" position, FaultFlash will enable a user to view the thermostat and count the fault indicator flashes to determine the lockout condition the unit is experiencing.

ComforTalk

When using a TP32U03, 04 or 05 thermostat and SW2-8 is in the pulsing "L" position, ComforTalk will enable the user to view the thermostat and determine the fault. The thermostat can be configured to show either lockout text or lockout codes.

The LED board on the front of the unit will display all lockouts. The Low Pressure LED will flash for a low pressure condition or a Comfort Alert fault. If the low pressure lockout was caused by Comfort Alert codes 4, 6 or 7, then the Comfort Alert will be flashing. If no Comfort Alert code is visible, then it is a low pressure lockout.

The following tables show the codes that will be displayed on the different ComforTalk and FaultFlash thermostats.

FaultFlash Thermostats

TA32W02 and TP32W03 Thermostats	
Thermostat Display Lockout Code	Lockout Description
2 Flashes	High Pressure Fault
3 Flashes	Low Pressure Fault
4 Flashes	Not Applicable
5 Flashes	Water Flow Fault
6 Flashes	Not Applicable
7 Flashes	Condensate Fault
8 Flashes	Voltage out of Range
9 Flashes	RPM Fault
10 Flashes	Comfort Alert Compressor Module Fault

Lockout code 10 - see Comfort Alert module to determine the specific flash code for compressor abnormalities.

ComforTalk Thermostats

TP32U03, TP32U04 and TP32U05 Thermostats	
Thermostat Display Lockout Code	Lockout Description
"High Pressure" or "E2"	High Pressure Fault
"Low Pressure" or "E3"	Low Pressure Fault
"E4"	Not Applicable
"Water Flow" or "E5"	Water Flow Fault
"E6"	Not Applicable
"Condensate" or "E7"	Condensate Fault
"Voltage Range" or "E8"	Voltage out of Range
"RPM" or "E9"	RPM Fault
"Comfort Alert" or "E10"	Comfort Alert Compressor Module Fault

These thermostats can be configured to display the lockout condition "text" or error number.

* A slow flash of 1 second on and off means the heat pump microprocessor SW2-1 is configured for "Test Mode" or thermostat is miswired.

Lockout code 10 - see Comfort Alert module to determine the specific flash code for compressor abnormalities.

DIP Switch Settings

DIP SWITCH NUMBER		DESCRIPTION	OFF POSITION	ON POSITION
SW1	N/A	NOT USED	N/A	N/A
SW2	1	Service/Test Mode - Allows control of "NORM" or "TEST" operational modes. Test mode accelerates most timing functions 16 times to allow faster troubleshooting. Test mode also allows viewing the "CURRENT" status of the fault inputs on the LED display.	Test	Norm
	2	Freeze Detection Setting This DIP allows field selection of freeze detection fault sensing for well water (30°F) or anti-freeze protected earth loops (15°F).	Loop (Sensing 15° F)	Well (Sensing 30° F)
	3	Accessory Relay Allows field selection of the accessory relay to operate with the compressor or blower.	Blower	Comp
	4	NOT USED	N/A	N/A
	5	NOT USED	N/A	N/A
	6	Input Diagnostics - Allows viewing the inputs from the thermostat to the control board such as Y1, Y2, O, G, W, SL1-In on the LED display.	Diagnostic Inputs viewed at LEDs	Normal Display viewed at LEDs
	7	Output Diagnostics - Allows viewing the outputs from the control board such as the compressor, reversing valve, blower, and loop pump on the LED display.	Diagnostic Outputs viewed at LEDs	Normal Display viewed at LEDs
	8	Thermostat Selection Configures the control for a pulsed lockout signal (ComforTalk and FaultFlash thermostats) or continuous 5 VAC lockout signal.	Pulsed "L" signal	Continuous "L" signal
SW3	1	Single or Dual Capacity Operation	Dual Cap	1 Speed
	2	Zoned/Finish on Second Stage This switch allows the unit to down stage with the thermostat when off and finish with second stage when on. Finish on second stage reduces stage changing in reciprocating dual capacity compressors.	Normal - All other systems	Finish on 2nd Unzoned Dual Capacity E-Series or Premier 2 speed
	3	ECM Blower Monitoring - Set for No PRM on split systems	No RPM	RPM
	4	NOT USED	N/A	N/A
	5	On dual capacity units this switch allows stage change: on the fly when off, and 1 minute delay when on. A delay is required on all reciprocating dual capacity units.	G Series	E-Series or Premier

Refrigeration

Leak Testing

The refrigeration line set must be pressurized and checked for leaks before purging and charging the unit. To pressurize the line set, attach refrigerant gauges to the service ports and add an inert gas (nitrogen or dry carbon dioxide) until pressure reaches 60 to 90 PSIG. Never use oxygen or acetylene to pressure test. Use an electronic leak detector or a good quality bubble solution to detect leaks on all connections made in the field. Check the service valve ports and stem for leaks and all connections made in the field. If a leak is found, repair it and repeat the above steps. For safety reasons do not pressurize the system above 150 psi. Purge pressure from line set. The system is now ready for evacuating and charging.

System Evacuation

Ensure that the line set and air coil are evacuated before opening service valves to the split unit. The line set must be evacuated to at least 200 microns to remove the moisture and air that may still be in the line set and coil. Evacuate the system through both service ports to prevent false readings on the gauge because of pressure drop through service ports.

Charge Amount When Using GAH Air Handler

The Envision Split is shipped with a factory pre-charge. This volume of refrigerant is not sufficient to run the system and additional refrigerant must be added. If using an GAH Air Handler please refer to the table in this section for charge amounts to be added. The "Factory Charge" column is the charge amount the compressor section/split is shipped with from the factory. The "Charge Amount with GAH Air Handler" column is the total amount of charge for the GAH Air Handler + Compressor section/split. This column does not factor in additional refrigerant needed for the line set. The installer of the system must add charge appropriately for the specific length of the line set. A 3/8 in. liquid line is calculated at 0.50 oz. of charge per linear foot, and a 1/2 in. liquid line is calculated at 1.0 oz. of charge per linear foot using R-410A refrigerant. The suction line will not hold "liquid" and should be ignored for the charge calculation.

Example: GTS036/GAH036 with 20 ft. of 3/8 in. liquid line.
Remember that when using the GAH Air Handler, the column "Charge Amount with GAH Air Handler" will be used. Now calculate for the additional 20 ft. in set.
Additional refrigerant to be added = (20 ft. x 0.5 oz.)
= 10 oz.

Solution: 10 oz. should be added to the recommended charge of 86 oz. found in the "Charge Amount with GAH Air Handler" column for a total charge of 96 oz.

After initial charge, the system should be operated and the system subcooling and superheat verified to the Unit Operating Parameters table.

If an air handler manufactured by others is used then refrigerant should be added to the Envision Split factory pre-charge. Refrigerant should be added for liquid line length. This should result in a slightly under-charged system exhibiting low subcooling and high superheat. As charge is added, the subcooling should rise and the superheat should fall.

Charging the System

Charge Method – After purging and evacuating the line set, fully open the service valves counterclockwise. Add R-410A (liquid) into the liquid line service port until the pressure in the system reaches approximately 200 PSIG. Never add liquid refrigerant into the suction side of a compressor. Start the unit and measure superheat and subcooling. Keep adding refrigerant until the unit meets the superheat and subcooling values in the Operating Parameters tables.

Checking Superheat and Subcooling

Determining Superheat

1. Measure the temperature of the suction line at the point where the expansion valve bulb is clamped.
2. Determine the suction pressure in the suction line by attaching refrigeration gauges to the schrader connection on the suction side of the compressor.
3. Convert the pressure obtained in Step 2 to the saturation temperature by using the Pressure Temperature Conversion Chart for R-410A.
4. Subtract the temperature obtained in Step 3 from Step 1. The difference is the amount of superheat for the unit. Refer to the Operating Parameters tables for superheat ranges at specific entering water conditions.

Superheat Adjustment

TXVs are factory set to a specific superheat; however, the superheat should be adjusted for the application. To adjust the TXV to other superheat settings:

1. Remove the seal cap from the bottom of the valve.
2. Turn the adjustment screw clockwise to increase superheat and counterclockwise to decrease superheat. One complete 360° turn changes the superheat approximately 3-4°F, regardless of refrigerant type. You may need to allow as much as 30 minutes after the adjustment is made for the system to stabilize.
3. Once the proper superheat setting has been achieved, replace and tighten the seal cap.

WARNING: There are 8 total (360°) turns on the superheat adjustment stem from wide open to fully closed. When adjusting the superheat stem clockwise (superheat increase) and the stop is reached, any further clockwise turning adjustment will damage the valve.

Refrigeration cont.

Determining Subcooling

1. Measure the temperature of the liquid line on the small refrigerant line (liquid line) just outside the split cabinet. This location will be adequate for measurement in both modes unless a significant temperature drop in the liquid line is anticipated.
2. Measure the liquid line pressure by attaching refrigerant gauges to the schrader connection on the liquid line service valve.
3. Convert the pressure obtained in Step 2 to the saturation temperature by using the Pressure Temperature Conversion Chart for R-410A.
4. Subtract the temperature in Step 1 from the temperature in Step 3. The difference will be the subcooling value for that unit. Refer to the Operating Parameters tables for subcooling ranges at specific enter water conditions.

Line Set Sizes

Unit Size	Air Handler	20 feet		40 feet		60 feet		Factory Charge (oz.)	*Charge Amount with GAH Air Handler (oz.)
		Suction	Liquid	Suction	Liquid	Suction	Liquid		
026	GAH026	5/8" OD	3/8" OD	3/4" OD	3/8" OD	3/4" OD	1/2" OD	52	74
038	GAH036	3/4" OD	3/8" OD	3/4" OD	3/8" OD	3/4" OD	1/2" OD	56	86
049	GAH048	3/4" OD	3/8" OD	7/8" OD	3/8" OD	7/8" OD	1/2" OD	90	115
064	GAH060	7/8" OD	1/2" OD	7/8" OD	1/2" OD	1-1/8" OD	1/2" OD	92	112
072	GAH060	7/8" OD	1/2" OD	7/8" OD	1/2" OD	1-1/8" OD	1/2" OD	104	132

NOTES: * The "Charge Amount with GAH Air Handler" column is based on the charge amount for an GAH Air Handler + Compressor Section Split.

Additional charge will have to be added accordingly for line set length.

After charge is added, adjustments can be made to get appropriate subcooling and superheat.

Additional charge for R-410A is 0.50 oz. per ft. for 3/8 in. and 1.0 oz. per ft. for 1/2 in. tube.

4/16/10

Pressure/Temperature Conversion Chart for R-410A

PRESSURE (PSIG)	TEMP °F	PRESSURE (PSIG)	TEMP °F	PRESSURE (PSIG)	TEMP °F	PRESSURE (PSIG)	TEMP °F	PRESSURE (PSIG)	TEMP °F
60	8.5	180	63.5	300	96.3	420	120.6	540	140.0
62	9.9	182	64.2	302	96.8	422	120.9	542	140.3
64	11.2	184	64.8	304	97.2	424	121.3	544	140.6
66	12.5	186	65.5	306	97.7	426	121.6	546	140.9
68	13.8	188	66.1	308	98.1	428	122.0	548	141.2
70	15.1	190	66.8	310	98.6	430	122.3	550	141.4
72	16.3	192	67.4	312	99.0	432	122.7	552	141.7
74	17.5	194	68.0	314	99.5	434	123.0	554	142.0
76	18.7	196	68.7	316	99.9	436	123.4	556	142.3
78	19.8	198	69.3	318	100.4	438	123.7	558	142.6
80	21.0	200	69.9	320	100.8	440	124.1	560	142.9
82	22.1	202	70.5	322	101.2	442	124.4	562	143.2
84	23.2	204	71.1	324	101.7	444	124.8	564	143.5
86	24.3	206	71.7	326	102.1	446	125.1	566	143.7
88	25.4	208	72.3	328	102.5	448	125.4	568	144.0
90	26.5	210	72.9	330	103.0	450	125.8	570	144.3
92	27.5	212	73.5	332	103.4	452	126.1	572	144.6
94	28.6	214	74.1	334	103.8	454	126.5	574	144.9
96	29.6	216	74.7	336	104.2	456	126.8	576	145.1
98	30.6	218	75.3	338	104.7	458	127.1	578	145.4
100	31.6	220	75.8	340	105.1	460	127.5	580	145.7
102	32.6	222	76.4	342	105.5	462	127.8	582	146.0
104	33.5	224	77.0	344	105.9	464	128.1	584	146.2
106	34.5	226	77.5	346	106.3	466	128.5	586	146.5
108	35.4	228	78.1	348	106.7	468	128.8	588	146.8
110	36.4	230	78.7	350	107.2	470	129.1	590	147.1
112	37.3	232	79.2	352	107.6	472	129.4	592	147.3
114	38.2	234	79.8	354	108.0	474	129.8	594	147.6
116	39.1	236	80.3	356	108.4	476	130.1	596	147.9
118	40.0	238	80.9	358	108.8	478	130.4	598	148.2
120	40.9	240	81.4	360	109.2	480	130.7	600	148.4
122	41.7	242	81.9	362	109.6	482	131.1	602	148.7
124	42.6	244	82.5	364	110.0	484	131.4	604	149.0
126	43.4	246	83.0	366	110.4	486	131.7	606	149.2
128	44.3	248	83.5	368	110.8	488	132.0	608	149.5
130	45.1	250	84.1	370	111.2	490	132.3		
132	45.9	252	84.6	372	111.6	492	132.7		
134	46.7	254	85.1	374	112.0	494	133.0		
136	47.5	256	85.6	376	112.3	496	133.3		
138	48.3	258	86.1	378	112.7	498	133.6		
140	49.1	260	86.6	380	113.1	500	133.9		
142	49.9	262	87.1	382	113.5	502	134.2		
144	50.7	264	87.7	384	113.9	504	134.5		
146	51.5	266	88.2	386	114.3	506	134.9		
148	52.2	268	88.7	388	114.7	508	135.2		
150	53.0	270	89.2	390	115.0	510	135.5		
152	53.7	272	89.6	392	115.4	512	135.8		
154	54.5	274	90.1	394	115.8	514	136.1		
156	55.2	276	90.6	396	116.2	516	136.4		
158	55.9	278	91.1	398	116.5	518	136.7		
160	56.6	280	91.6	400	116.9	520	137.0		
162	57.4	282	92.1	402	117.3	522	137.3		
164	58.1	284	92.6	404	117.6	524	137.6		
166	58.8	286	93.0	406	118.0	526	137.9		
168	59.5	288	93.5	408	118.4	528	138.2		
170	60.2	290	94.0	410	118.7	530	138.5		
172	60.8	292	94.5	412	119.1	532	138.8		
174	61.5	294	94.9	414	119.5	534	139.1		
176	62.2	296	95.4	416	119.8	536	139.4		
178	62.9	298	95.8	418	120.2	538	139.7		

Operating Parameters

First Stage Operation

Cooling -- No Hot Water Generator									
Entering Water Temp °F	Water Flow GPM/Ton	GTS026 thru GTS064		GTS072		GTS026 thru GTS072			
		Suction Pressure PSIG	Discharge Pressure PSIG	Suction Pressure PSIG	Discharge Pressure PSIG	Superheat	Subcooling	Water Temp Rise °F	Air Temp Drop °F DB
50	1.5	130-150	193-230	130-150	200-245	8-16	7-14	15-21	18-24
	3.0	128-153	190-230	125-140	205-240	8-16	3-10	9-14	18-25
70	1.5	130-150	238-282	135-150	240-280	6-16	4-16	12-18	18-25
	3.0	130-155	238-262	125-145	245-270	6-18	5-11	5-10	18-24
90	1.5	133-148	308-340	130-155	300-365	7-16	6-18	10-16	19-25
	3.0	138-153	303-333	130-165	305-350	7-18	7-14	5-10	17-22

Heating -- No Hot Water Generator									
Entering Water Temp °F	Water Flow GPM/Ton	GTS026 thru GTS064		GTS072		GTS026 thru GTS072			
		Suction Pressure PSIG	Discharge Pressure PSIG	Suction Pressure PSIG	Discharge Pressure PSIG	Superheat	Subcooling	Water Temp Drop °F	Air Temp Rise °F DB
30	1.5	78-100	275-325	85-105	325-385	6-11	4-16	5-9	20-29
	3.0	78-110	285-325	90-120	335-375	6-11	4-16	3-7	20-32
50	1.5	105-120	305-350	100-130	340-400	5-12	4-16	5-12	24-32
	3.0	110-125	305-355	110-125	345-395	9-15	2-14	4-9	20-34
70	1.5	140-155	305-355	130-165	370-430	5-12	2-14	8-12	24-39
	3.0	145-160	330-360	140-160	375-425	7-17	7-15	4-10	24-39

Second Stage Operation

Cooling -- No Hot Water Generator									
Entering Water Temp °F	Water Flow GPM/Ton	GTS026 thru GTS064		GTS072		GTS026 thru GTS072			
		Suction Pressure PSIG	Discharge Pressure PSIG	Suction Pressure PSIG	Discharge Pressure PSIG	Superheat	Subcooling	Water Temp Rise °F	Air Temp Drop °F DB
50	1.5	120-140	200-245	105-150	210-270	7-17	6-14	15-21	19-26
	3.0	115-140	195-290	110-130	215-260	7-15	4-11	9-14	20-24
70	1.5	121-136	265-310	105-150	280-350	9-15	6-18	12-18	19-25
	3.0	123-139	265-310	110-140	285-320	10-16	8-16	5-10	18-24
90	1.5	122-140	310-360	115-140	325-385	8-14	6-18	10-16	18-24
	3.0	123-139	310-350	120-135	330-355	8-14	7-15	5-10	17-23

Heating -- No Hot Water Generator									
Entering Water Temp °F	Water Flow GPM/Ton	GTS026 thru GTS064		GTS072		GTS026 thru GTS072			
		Suction Pressure PSIG	Discharge Pressure PSIG	Suction Pressure PSIG	Discharge Pressure PSIG	Superheat	Subcooling	Water Temp Drop °F	Air Temp Rise °F DB
30	1.5	72-89	295-350	70-100	320-370	7-18	10-20	5-9	18-24
	3.0	73-87	305-330	75-90	315-365	7-18	10-20	3-7	18-27
50	1.5	100-120	320-365	95-130	375-430	6-14	6-18	5-12	23-34
	3.0	105-120	355-365	100-125	370-420	6-14	6-18	4-9	20-37
70	1.5	142-158	360-380	130-165	400-470	6-12	4-15	8-12	28-38
	3.0	138-152	365-390	135-160	405-465	7-14	4-15	4-10	24-42

Cooling performance based on entering air temperatures of 80°F DB, 67°F WB.

Heating performance based on entering air temperature of 70°F DB.

Pressure Drop

Dual Capacity

Model	GPM	Pressure Drop (psi)				
		30°F	50°F	70°F	90°F	110°F
026 full load	4	1.4	1.3	1.2	1.1	1.0
	6	2.8	2.6	2.4	2.3	2.1
	8	4.7	4.4	4.1	3.8	3.5
	10	7.0	6.6	6.2	5.8	5.3
026 part load	3	0.8	0.7	0.7	0.7	0.6
	5	2.0	1.8	1.7	1.6	1.5
	7	3.6	3.4	3.2	3.0	2.8
	9	5.8	5.5	5.1	4.8	4.4
038 full load	5	1.2	1.2	1.1	1.0	1.0
	7	2.2	2.1	1.9	1.8	1.7
	9	3.4	3.2	3.0	2.8	2.6
	11	4.9	4.6	4.3	4	3.7
038 part load	4	0.9	0.8	0.8	0.7	0.7
	6	1.7	1.6	1.5	1.4	1.3
	8	2.8	2.6	2.5	2.3	2.1
	10	4.2	3.9	3.7	3.4	3.2
049 full load	6	1.2	1.2	1.1	1.0	1.0
	9	2.4	2.2	2.1	2.0	1.8
	12	3.9	3.6	3.4	3.2	2.9
	15	5.7	5.3	5	4.7	4.3
049 part load	5	0.9	0.9	0.8	0.8	0.7
	8	2.0	1.8	1.7	1.6	1.5
	11	3.4	3.1	2.9	2.8	2.5
	14	5.0	4.7	4.4	4.1	3.8
064 full load	8	1.8	1.7	1.6	1.4	1.3
	12	3.8	3.5	3.3	3.0	2.8
	16	6.5	6.0	5.6	5.2	4.8
	20	9.7	9.1	8.5	8.0	7.4
064 part load	6	1.0	0.9	0.9	0.8	0.8
	10	2.6	2.5	2.3	2.1	2.0
	14	5.0	4.7	4.4	4.1	3.8
	18	8.1	7.6	7.1	6.6	6.1
072 full load	12	3.2	3.0	2.8	2.6	2.4
	15	4.5	4.2	4.0	3.7	3.4
	18	6.0	5.7	5.3	4.9	4.6
	21	7.8	7.3	6.8	6.4	5.9
072 part load	10	2.3	2.1	2.0	1.9	1.7
	13	3.6	3.3	3.0	2.8	2.6
	16	5.0	4.6	4.3	4.0	3.7
	19	6.5	6.2	5.8	5.4	5.0

5/30/06

Compressor Resistance

Model	208-230/60/1	
	Run (Ohms)	Start (Ohms)
026	1.23-1.41	1.30-1.50
038	.829-.954	1.19-1.38
049	.590-.679	1.41-1.62
064	.455-.524	.558-.643
072	.344-.395	.495-.570

1/13/11

Thermistor Resistance

Thermistor Temperature (°F)	Microprocessor Resistance (Ohms)
5	75757-70117
14	57392-53234
23	43865-40771
32	33809-31487
41	26269-24513
50	20570-19230
59	16226-15196
68	12889-12093
77	10310-9688
86	8300-7812
95	6723-6337
104	5480-5172
113	4490-4246
122	3700-3504
131	3067-2907
140	2554-2424
149	2149-2019

7/6/10

Refrigerant Circuit Guideline

Symptom	Head Pressure	Suction Pressure	Compressor Amp Draw	Superheat	Subcooling	Air Temp. Differential	Water Temp. Differential
Under Charged System (Possible Leak)	Low	Low	Low	High	Low	Low	Low
Over Charged System	High	High	High	Normal	High	Normal/Low	Normal
Low Air Flow Heating	High	High	High	High/Normal	Low	High	Low
Low Air Flow Cooling	Low	Low	Low	Low/Normal	High	High	Low
Low Water Flow Heating	Low/Normal	Low/Normal	Low	Low	High	Low	High
Low Water Flow Cooling	High	High	High	High	Low	Low	High
High Air Flow Heating	Low	Low	Low	Low	High	Low	Low
High Air Flow Cooling	Low	High	Normal	High	Low	Low	Normal
High Water Flow Heating	Normal	Low	Normal	High	Normal	Normal	Low
High Water Flow Cooling	Low	Low	Low	Low	High	Normal	Low
Low Indoor Air Temperature Heating	Low	Low	Low	Normal	High	Normal	Normal/High
Low Indoor Air Temperature Cooling	Low	Low	Low	Normal/Low	High	Low	Low
High Indoor Air Temperature Heating	High	High	High	Normal/High	Normal/Low	Low	Normal
High Indoor Air Temperature Cooling	High	High	High	High	Low	Low	High
Restricted TXV (Check Service Advisory)	High	Low	Normal/Low	High	High	Low	Low
Insufficient Compressor (Possible Bad Valves)	Low	High	Low	High	Normal/High	Low	Low
TXV - Bulb Loss of Charge	Low	Low	Low	High	High	Low	Low
Scaled Coaxial Heat Exchanger Heating	Low	Low	Low	Normal/Low	High	Low	Low
Scaled Coaxial Heat Exchanger Cooling	High	High	High	Normal/Low	Low	Low	Low
Restricted Filter Drier	Check temperature difference (delta T) across filter drier.						

7/6/10

Heat of Extraction/Rejection Data

Model	GPM	Heat of Extraction (kBtu/h)				Heat of Rejection (kBtu/h)					
		30°F	50°F	70°F	90°F	30°F	50°F	70°F	90°F	110°F	
026	Part Load	3.0	13.1	17.6	21.5		23.5	22.9	21.8		
		5.0	9.4	13.8	18.6	21.7	23.6	23.0	21.7	20.2	
		7.0	9.6	14.1	18.9	23.0	21.9	23.7	23.1	20.2	
	Full Load	4.0		17.8	23.4	28.5		31.0	31.2	30.0	
		6.0	13.4	18.8	24.7	29.9	29.9	31.1	31.3	29.9	28.1
		8.0	13.6	19.3	25.1	30.5	30.1	31.2	31.3	29.9	28.1
038	Part Load	4.0		17.9	23.3	28.1		32.5	31.8	30.0	
		6.0	12.8	18.7	24.5	29.8	29.8	32.7	32.0	30.1	28.2
		8.0	13.9	19.7	25.2	29.8	30.3	33.1	32.4	30.4	28.5
	Full Load	5.0		25.1	31.5	36.1		44.8	45.1	42.8	
		7.0	18.7	26.2	33.2	38.6	41.8	45.2	45.7	43.6	41.0
		9.0	19.1	26.9	34.3	40.0	42.0	45.5	46.0	43.8	41.1
049	Part Load	5.0		24.0	29.5	33.7		44.9	46.1	44.0	
		8.0	19.2	26.4	32.6	37.5	40.6	45.0	45.8	43.4	40.5
		11.0	19.8	27.5	34.3	39.9	40.0	44.9	46.1	44.3	41.5
	Full Load	6.0		33.3	40.6	46.1		60.2	60.2	56.4	
		9.0	26.0	34.7	42.8	49.1	56.0	60.2	60.8	57.4	52.9
		12.0	26.5	35.7	44.2	50.9	56.1	60.4	61.1	57.6	53.2
064	Part Load	6.0		31.0	39.2	46.1		56.3	55.4	52.1	
		10.0	21.6	31.4	40.9	49.7	52.4	56.2	55.5	52.4	49.4
		14.0	22.6	32.6	41.7	49.8	52.2	56.2	55.6	52.6	49.7
	Full Load	8.0		40.8	52.7	64.7		73.7	75.7	70.3	
		12.0	31.9	43.8	55.1	65.8	66.8	74.1	76.1	70.5	66.2
		16.0	32.2	44.7	56.8	68.6	67.2	74.5	76.5	70.9	66.3
072	Part Load	10.0		36.4	46.5	54.7		63.4	63.0	58.9	
		13.0	25.2	36.7	48.5	59.1	57.7	63.2	63.0	59.2	55.1
		16.0	26.7	38.2	49.4	59.1	57.3	63.2	63.3	59.5	55.4
	Full Load	12.0		48.3	62.7	69.0		81.8	83.0	77.8	
		15.0	37.2	51.6	65.4	70.9	73.6	82.1	83.3	78.0	71.9
		18.0	37.6	52.7	67.5	73.5	74.1	82.6	83.8	78.4	72.2

1/14/11

Reference Calculations

Heating Calculations:	Cooling Calculations:
$LWT = EWT - \frac{HE}{GPM \times 500}$	$LWT = EWT + \frac{HR}{GPM \times 500}$
$LAT = EAT + \frac{HC}{CFM \times 1.08}$	$LAT (DB) = EAT (DB) - \frac{SC}{CFM \times 1.08}$
$TH = HC + HW$	$LC = TC - SC$
	$S/T = \frac{SC}{TC}$

Legend

ABBREVIATIONS AND DEFINITIONS:

CFM = airflow, cubic feet/minute	HE = total heat of extraction, MBTUH
EWT = entering water temperature, Fahrenheit	HW = desuperheater capacity, MBTUH
GPM = water flow in gallons/minute	EER = Energy Efficient Ratio
WPD = water pressure drop, PSI and feet of water	= BTU output/Watt input
EAT = entering air temperature, Fahrenheit (dry bulb/wet bulb)	COP = Coefficient of Performance
HC = air heating capacity, MBTUH	= BTU output/BTU input
TC = total cooling capacity, MBTUH	LWT = leaving water temperature, °F
SC = sensible cooling capacity, MBTUH	LAT = leaving air temperature, °F
KW = total power unit input, kilowatts	TH = total heating capacity, MBTUH
HR = total heat of rejection, MBTUH	LC = latent cooling capacity, MBTUH
	S/T = sensible to total cooling ratio

Operating Limits

Operating Limits	Cooling	Heating
Air Limits		
Minimum ambient air, DB	-10°F [-23.3°C]	-10°F [-23.3°C]
Rated ambient air, DB	80.0 [26.7°C]	70°F [21.1°C]
Maximum ambient air, DB	120 [48.8°C]	85°F [29°C]
Water Limits		
Minimum entering water	30°F [-1°C]	20°F [-6.7°C]
Normal entering water	50-110°F [10-43°C]	30-70°F [-1 to 21°C]
Maximum entering water	120°F [49°C]	90°F [32°C]
Normal water flow	1.5 to 3.0 gpm per ton [1.6 to 3.2 l/m per kW]	

NOTES: Minimum/maximum limits are only for start-up conditions, and are meant for bringing the space up to occupancy temperature. Units are not designed to operate at the minimum/maximum conditions on a regular basis. The operating limits are dependant upon three primary factors: 1) water temperature, 2) return air temperature, and 3) ambient temperature. When any of the factors are at the minimum or maximum levels, the other two factors must be at the normal level for proper and reliable unit operation.

Startup

Before Powering Unit, Check The Following:

- High voltage is correct and matches nameplate.
- Fuses, breakers and wire size correct.
- Low voltage wiring complete.
- Piping completed and water system cleaned and flushed.
- Air is purged from closed loop system.
- Isolation valves are open, water control valves or loop pumps wired.
- Transformer switched to 208V if applicable.
- DIP switches are set correctly.
- DHW pump switch is "OFF" unless piping is completed and air has been purged.
- Blower rotates freely.
- Blower speed correct.
- Air filter/cleaner is clean and in position.
- Service/access panels are in place.
- Return air temperature is between 50-80°F heating and 60-95°F cooling.
- Check air coil cleanliness to ensure optimum performance. Clean as needed according to maintenance guidelines. To obtain maximum performance the air coil should be cleaned before startup. A 10-percent solution of dishwasher detergent and water is recommended for both sides of coil, a thorough water rinse should follow.

Startup Steps

NOTES: Complete the Equipment Start-Up/Commissioning Check Sheet during this procedure. Refer to thermostat operating instructions and complete the startup procedure.

1. Initiate a control signal to energize the blower motor. Check blower operation.
2. Initiate a control signal to place the unit in the cooling mode. Cooling setpoint must be set below room temperature.
3. First stage cooling will energize after a time delay.
4. Be sure that the compressor and water control valve or loop pump(s) are activated.
5. Verify that the water flow rate is correct by measuring the pressure drop through the heat exchanger using the P/T plugs and comparing to unit capacity data in specification catalog.
6. Check the temperature of both the supply and discharge water (see Operating Parameters tables).
7. Check for an air temperature drop of 15°F to 25°F across the air coil, depending on the blower speed and entering water temperature.
8. Decrease the cooling set point several degrees and verify high-speed blower operation.
9. Adjust the cooling setpoint above the room temperature and verify that the compressor and water valve or loop pumps deactivate.
10. Initiate a control signal to place the unit in the heating mode. Heating set point must be set above room temperature.
11. First stage heating will energize after a time delay.
12. Check the temperature of both the supply and discharge water (see Operating Parameters tables).
13. Check for an air temperature rise of 20°F to 35°F across the air coil, depending on the blower speed and entering water temperature.
14. If auxiliary electric heaters are installed, increase the heating setpoint until the electric heat banks are sequenced on. All stages of the auxiliary heater should be sequenced on when the thermostat is in the Emergency Heat mode. Check amperage of each element.
15. Adjust the heating setpoint below room temperature and verify that the compressor and water valve or loop pumps deactivate.
16. During all testing, check for excessive vibration, noise or water leaks. Correct or repair as required.
17. Set system to desired normal operating mode and set temperature to maintain desired comfort level.
18. Instruct the owner/operator in the proper operation of the thermostat and system maintenance.

NOTES: Be certain to fill out and forward all warranty registration papers.

Final Evaluation

After the initial check of superheat/subcooling values in the heating mode, shut off the unit and allow it to sit 3 to 5 minutes until pressures equalize. Restart the unit in the cooling mode and check the values against those in the Operating Parameters tables. If the unit performs satisfactorily, charging is complete. If the unit does not perform to specifications, the charge may need to be readjusted until the values are close. Adding refrigerant will increase subcooling. Recovering some of the refrigerant will decrease subcooling and increase superheat. If the superheat/subcooling values are still not close to the specifications in the Operating Parameters tables, analyze refrigerant circuit operation.

Startup and Troubleshooting

Heating Cycle Analysis

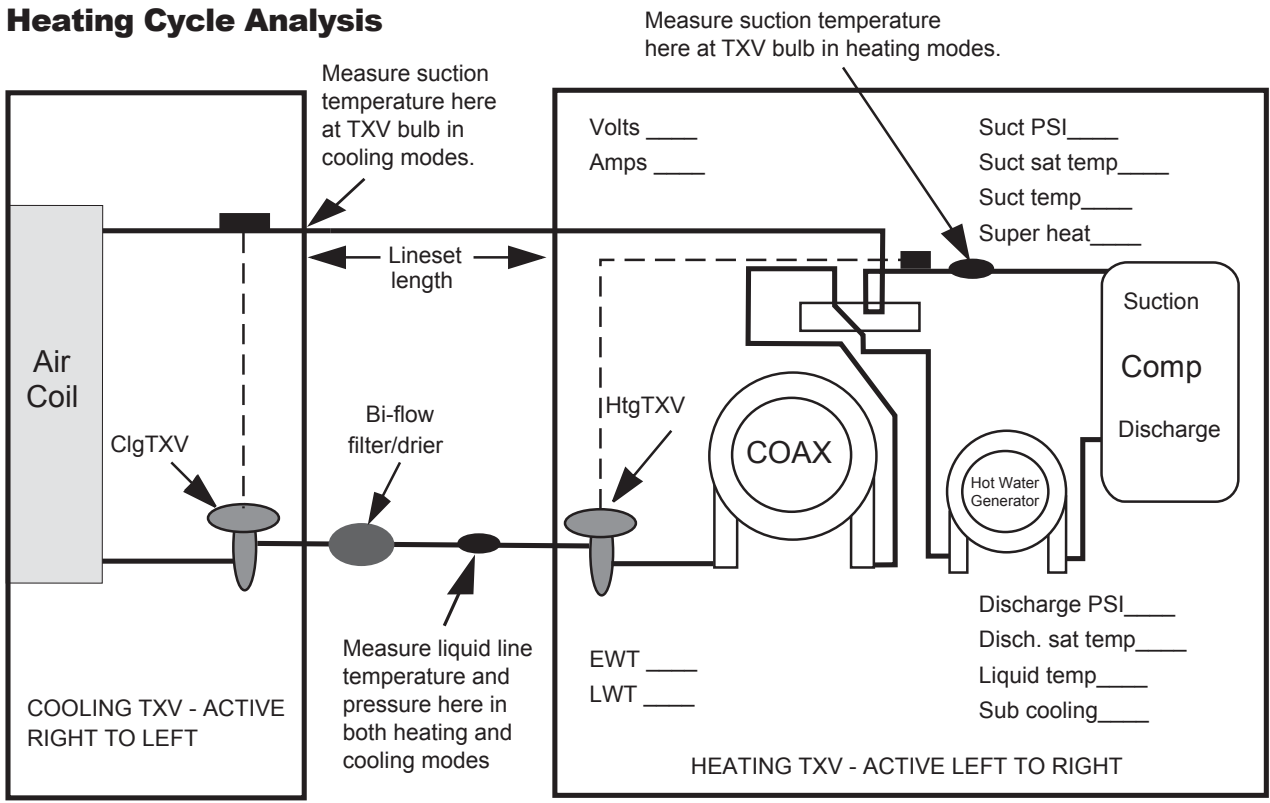

Heat of Extraction/Rejection = GPM x 500 (485 for water/antifreeze) x ΔT
Note: DO NOT hook up pressure gauges unless there appears to be a performance problem.

Cooling Cycle Analysis

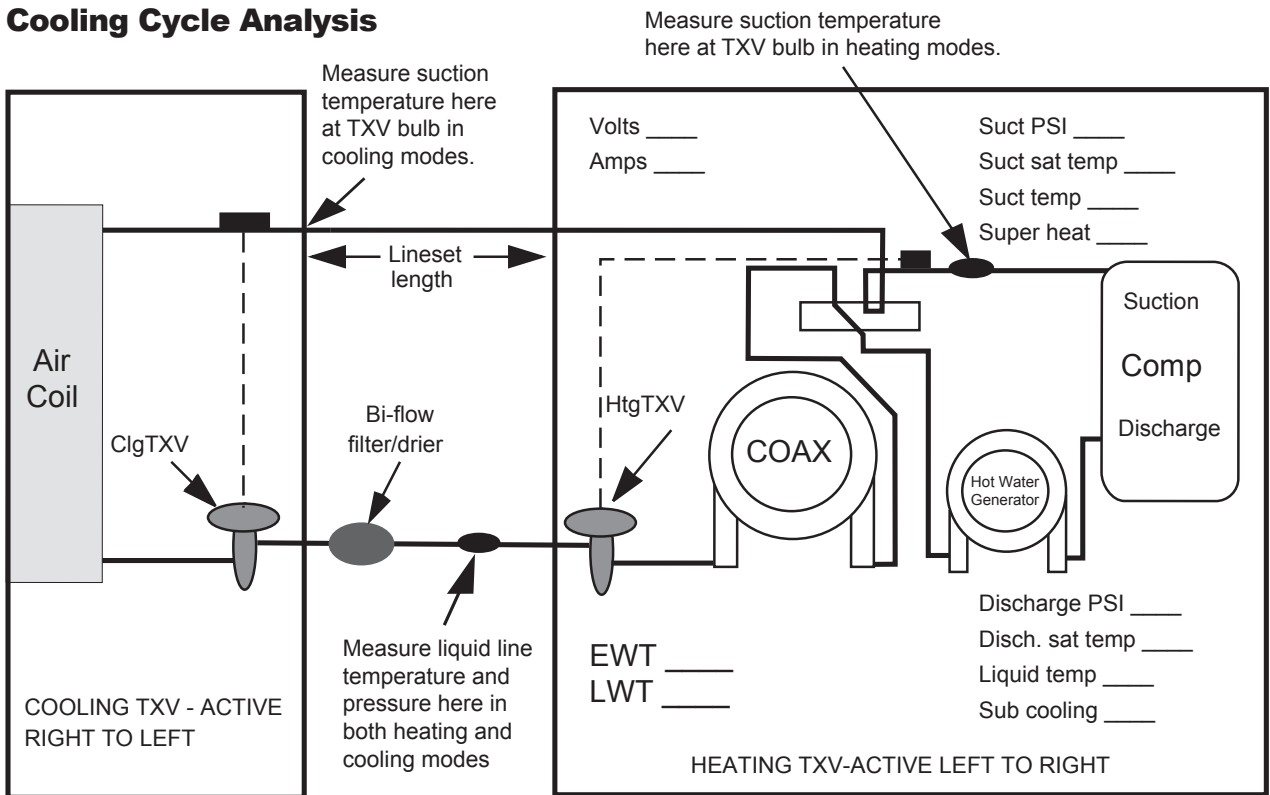

Troubleshooting

Standard Microprocessor Controls

To check the unit control board for proper operation:

1. Disconnect thermostat wires at the control board.
2. Jumper the desired test input (Y1, Y2, W, O or G) to the R terminal to simulate a thermostat signal.
3. If control functions properly:
 - Check for thermostat and field control wiring (use the diagnostic inputs mode).
4. If control responds improperly:
 - Ensure that component being controlled is functioning (compressor, blower, reversing valve, etc.).
 - Ensure that wiring from control to the component is functioning (refer to the LED Definition table below and use the diagnostic outputs mode).
 - If steps above check properly, replace unit control.

LED Definitions and Diagnostics

Standard Microprocessor

LED	NORMAL DISPLAY MODE		DIAGNOSTIC MODES							
			CURRENT FAULT STATUS		INPUTS		OUTPUTS 1		OUTPUTS 2	
	Field Selection DIPS									
	SW2-	1 On	SW2-	1 Off	SW2-	1 NA	SW2-	1 NA	SW2-	1 NA
	SW2-	6 On	SW2-	6 On	SW2-	6 Off	SW2-	6 On	SW2-	6 Off
	SW2-	7 On	SW2-	7 On	SW2-	7 On	SW2-	7 Off	SW2-	7 Off
Drain	Drain Pan Overflow Lockout		Drain Pan Overflow		Y1		Compressor (On or Low)		Blower Low	
Water Flow	FD Thermistor (Loop <15°F, Well<30°F) Lockout		FD Thermistor (Loop <15°F, Well<30°F)		Y2		Compressor (On or High)		Blower Medium	
High Pressure	High Pressure >600 PSI Lockout		High Pressure >600		O		Reversing Valve		Blower High	
Low Pressure	Low Pressure <40		Low Pressure <40		G		Blower		Aux Heat 1	
Status	Microprocessor Malfunction		Not Used		SL1		Loop Pump 1		Aux Heat 3	
DHW Limit	HWL Thermistor >130°F		HWL Thermistor >130°F		Not Used		Loop Pump 2		Aux Heat 4	
DHW Off	DHW Pump Switch Off		DHW Pump Switch Off		-		-		-	

Refrigerant Systems

To maintain sealed circuit integrity, do not install service gauges unless unit operation appears abnormal. Compare the change in temperature on the air side as well as the water side to the Operating Parameters tables. If the unit's performance is not within the ranges listed, and the airflow and water flow are known to be correct, gauges should then be installed and superheat and subcooling numbers calculated. If superheat and subcooling are outside recommended ranges, an adjustment to the refrigerant charge may be necessary.

NOTES: Refrigerant tests must be made with hot water generator turned "OFF". Verify that air and water flow rates are at proper levels before servicing the refrigerant circuit.

Preventive Maintenance

Water Coil Maintenance

1. Keep all air out of the water. An open loop system should be checked to ensure that the well head is not allowing air to infiltrate the water line. Lines should always be airtight.
2. Keep the system under pressure at all times. It is recommended in open loop systems that the water control valve be placed in the discharge line to prevent loss of pressure during off cycles. Closed loop systems must have positive static pressure.

NOTES: On open loop systems, if the installation is in an area with a known high mineral content (125 PPM or greater) in the water, it is best to establish with the owner a periodic maintenance schedule so the coil can be checked regularly. Should periodic coil cleaning be necessary, use standard coil cleaning procedures which are compatible with either the cupronickel or copper water lines. Generally, the more water flowing through the unit the less chance for scaling.

Other Maintenance

Filters

Filters must be clean to obtain maximum performance. They should be inspected monthly under normal operating conditions and be replaced when necessary. Units should never be operated without a filter.

Condensate Drain

In areas where airborne bacteria produce a slime in the drain pan, it may be necessary to treat chemically to minimize the problem. The condensate drain can pick up lint and dirt, especially with dirty filters. Inspect twice a year to avoid the possibility of overflow.

Blower Motors

Blower motors on most air handlers are equipped with sealed ball bearings and require no periodic oiling.

Air Coil

The air coil must be cleaned to obtain maximum performance. Check once a year under normal operating conditions and, if dirty, brush or vacuum clean. Care must be taken not to damage the aluminum fins while cleaning.



CAUTION: Fin edges are sharp.

Replacement Procedures

Obtaining Parts

When ordering service or replacement parts, refer to the model number and serial number of the unit as stamped on the serial plate attached to the unit. If replacement parts are required, mention the date of installation of the unit and the date of failure, along with an explanation of the malfunctions and a description of the replacement parts required.

In-Warranty Material Return

Material may not be returned except by permission of authorized warranty personnel. Contact your local distributor for warranty return authorization and assistance.

Service Parts List

Part Description		Dual Capacity Split Units				
		026	038	049	064	072
Compressor	Compressor	34P585-01	34P573-01	34P574-01	34P575-01	34P586-01
	Run Capacitor	16P002D19	16P002D20	16P002D21	16P002D39	
	Sound Jacket	92P504A16				
	Power Harness	11P781-01				
	Solenoid Harness	11P782-01				
Refrigeration Components	Accumulator	36P509-02	36P509-01			
	Coax	62I504B01	62I542B01	62I543B01		
	TXV	33P609-01	33P609-03	33P609-05	33P609-06	
	Reversing Valve	33P506-04	33P503-05	33P526-04		
	Filter Dryer	36P500B01			36P500B02	
Electrical	Comfort Alert	19P571-02				
	Contactors	13P004A03				
	Transformer	15P501B01				
	3 Pole Power Block	12P503-06				
	2 Pole Screw Term. Block	12P500A01				
	Status Light Board	17P503-02				
	Harness, Status Light Board	11P783-01				
	Main Logic Board	17P513-07				
Sensors & Safeties	Freeze Detection Thermistor	12P505B03				
	High Pressure Switch	35P506B02				
	Low Pressure Switch	35P506B01				

Part numbers subject to change

11/12/10

Notes



Product: **GTS Series**
Type: Geothermal Outdoor Split Heat Pump
Size: 2-6 Tons Single Speed
2-6 Tons Dual Capacity

Document Type: Installation Manual
Part Number: IM1004SG1
Release Date: 03/11