

# GS/GT Series

## Geothermal/Water Source Heat Pumps

- R-410A Refrigerant
- 2, 2.5, 3, 3.5, 4, 5, 6 Ton Single Speed
- 2, 3, 4, 5, 6 Ton Dual Capacity

Installation Information

Water Piping Connections

Desuperheater Connections

Electrical

Startup Procedures

Troubleshooting

Preventive Maintenance





---

## Table of Contents

Model Nomenclature	2
General Installation Information	3-7
Closed Loop Ground Source Systems	8
Open Loop Ground Water Systems	9
Desuperheater Connection & Startup	10-11
Electrical Connections	12-13
Electronic Thermostat Installation	13
Auxiliary Heat Ratings	13
Unit Electrical Data	14-15
Blower Performance Data	16-17
Dimensional Data	18-21
Physical Data	22-23
Wiring Schematics	24-35
Microprocessor Control	36-40
Optional FX10 Microprocessor Control	41
Operation Logic Data	42
Unit Startup	43
Unit Operating Parameters	44-45
Pressure Drop	46
Troubleshooting	47
Preventive Maintenance	48
Replacement Procedures	48

# GS/GT Series



## Model Nomenclature

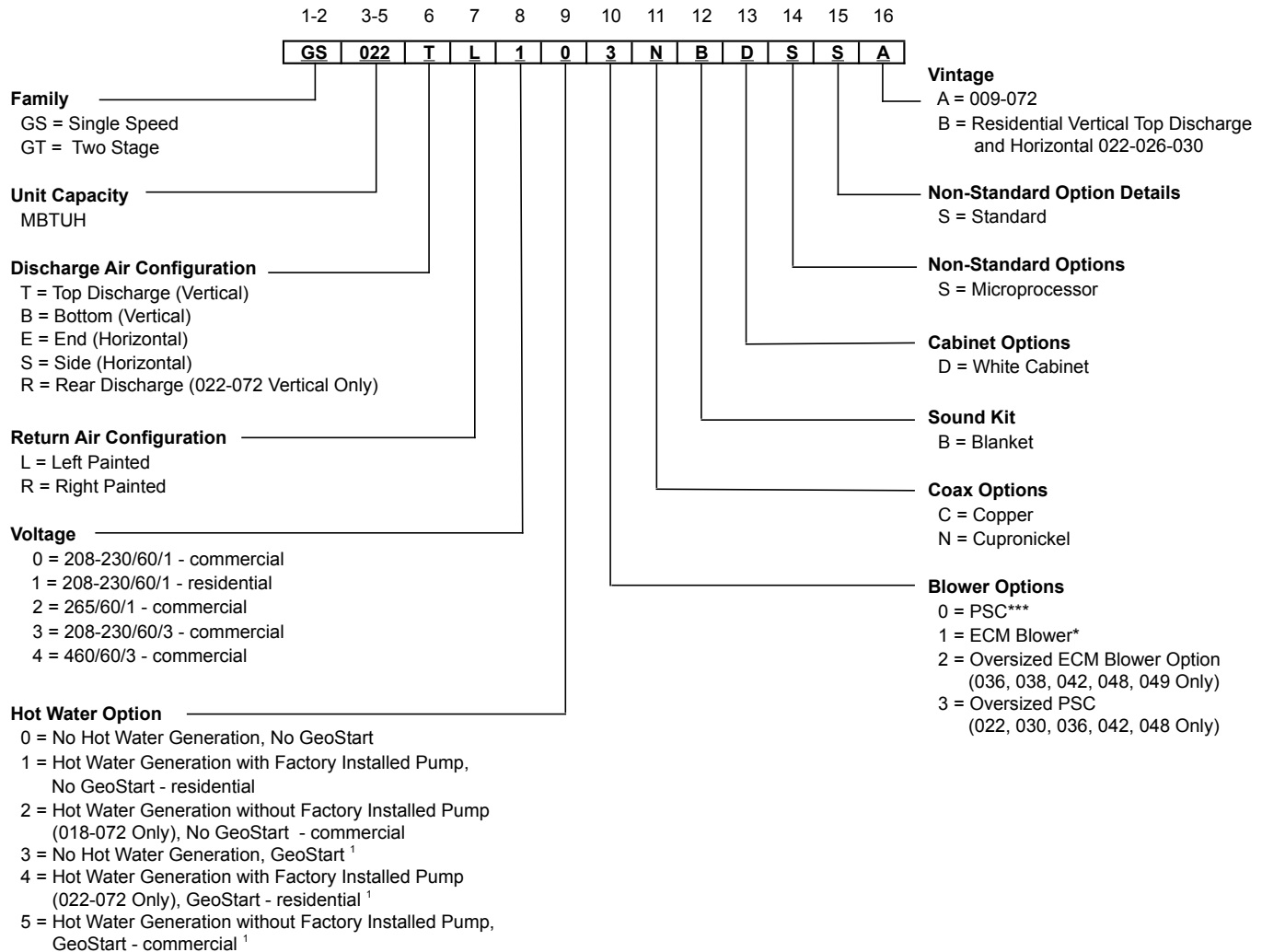

\* Not available on 009-012

\*\*\* Not available on dual capacity models, nor 265V 030

<sup>1</sup> Not available in model sizes 009-018

# General Installation Information

## Safety Considerations



**WARNING:** Before performing service or maintenance operations on a system, turn off main power switches to the indoor unit. If applicable, turn off the accessory heater power switch. Electrical shock could cause personal injury.

Installing and servicing heating and air conditioning equipment can be hazardous due to system pressure and electrical components. Only trained and qualified service personnel should install, repair or service heating and air conditioning equipment. Untrained personnel can perform the basic maintenance functions of cleaning coils and cleaning and replacing filters. All other operations should be performed by trained service personnel. When working on heating and air conditioning equipment, observe precautions in the literature, tags and labels attached to the unit and other safety precautions that may apply.

Follow all safety codes. Wear safety glasses and work gloves. Use a quenching cloth for brazing operations and have a fire extinguisher available.

## Moving and Storage

Move units in the normal “up” orientation. Horizontal units may be moved and stored per the information on the packaging. Do not stack more than three units in total height. Vertical units may be stored one upon another to a maximum height of two units. Do not attempt to move units while stacked. When the equipment is received, all items should be carefully checked against the bill of lading to be sure all crates and cartons have been received. Examine units for shipping damage, removing the units from the packaging if necessary. Units in question should also be internally inspected. If any damage is noted, the carrier should make the proper notation on the delivery receipt, acknowledging the damage.

## Unit Location

Locate the unit in an indoor area that allows for easy removal of the filter and access panels. Location should have enough space for service personnel to perform maintenance or repair. Provide sufficient room to make water, electrical and duct connection(s). If the unit is located in a confined space, such as a closet, provisions must be made for return air to freely enter the space by means of a louvered door, etc. Any access panel screws that would be difficult to remove after the unit is installed should be removed prior to setting the unit. On horizontal units, allow adequate room below the unit for a condensate drain trap and do not locate the unit above supply piping. **Care should be taken when units are located in unconditioned spaces to prevent damage from frozen water lines and excessive heat that could damage electrical components.**

## Installing Vertical Units

Prior to setting the unit in place, remove and discard the compressor hold down shipping bolt located at the front of the compressor mounting bracket.

Vertical units are available in left or right air return configurations. Top or rear flow vertical units should be mounted level on a vibration absorbing pad slightly larger than the base to provide isolation between the unit and the floor. It is not necessary to anchor the unit to the floor (see right).

Bottom flow units should be mounted level and sealed well to floor to prevent air leakage. Bottom flow units require the supply air opening to be cut at least 1/2” larger than the unit’s air outlet. Protect the edges of combustible flooring with sheet metal over-wrap or other non-combustible material.

Figure 1: Vertical Unit Mounting

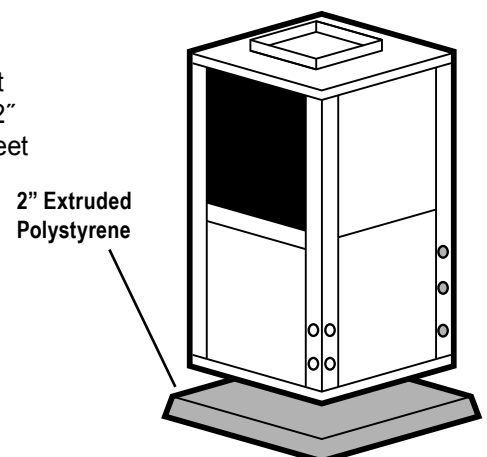

# General Installation Information cont.

## Installing Horizontal Units

Remove and discard the compressor hold down shipping bolt located at the front of the compressor mounting bracket prior to setting the unit in place. Horizontal units are available with side or end discharge. Horizontal units are normally suspended from a ceiling by six 3/8-inch diameter threaded rods. The rods are usually attached to the unit by hanger bracket kits furnished with each unit.

Lay out the threaded rods per the dimensions below. Assemble the hangers to the unit as shown. Securely tighten the brackets to the unit using the weld nuts located on the underside of the bottom panel. When attaching the hanger rods to the bracket, a double nut is required since vibration could loosen a single nut. To allow filter access, one bracket on the filter side should be installed 180° from the position shown in the figure below. The unit should be pitched approximately 1/4-inch towards the drain in both directions to facilitate the removal of condensate. Use only the bolts provided in the kit to attach hanger brackets. The use of longer bolts could damage internal parts.

Some residential applications require the installation of horizontal units on an attic floor. In this case, the unit should be set in a full size secondary drain pan on top of a vibration absorbing pad. The secondary drain pan prevents possible condensate overflow or water leakage damage to the ceiling. The secondary drain pan is usually placed on a plywood base isolated from the ceiling joists by additional layers of vibration absorbing material.



**CAUTION:** Do not use rods smaller than 3/8-inch diameter since they may not be strong enough to support the unit. The rods must be securely anchored to the ceiling.

Figure 2: Horizontal Unit Mounting

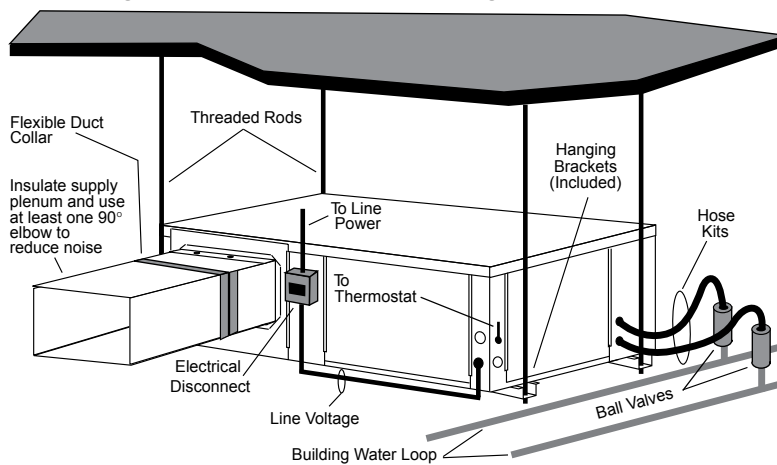
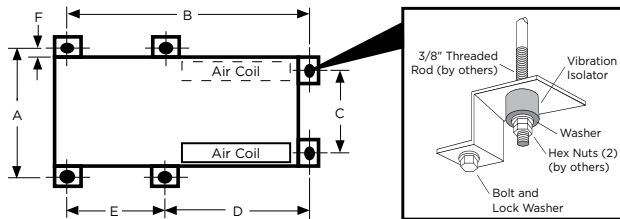

Figure 3: Hanger Location and Assembly



Model	Hanger Kit Part Number	A	B	C	D	E	F
009 - 012*	995500A04	25.1	44.7	21.4	N/A	N	N
015 - 018*	995500A04	25.1	53.7	21.4	N/A	N	N
022 - 030*	995500A04	24.8	63.4	21.1	N/A	N	N
036 - 038	995500A03	27.8	72.4	24.1	43.1	25.1	25.1
042 - 049	995500A03	27.8	77.4	24.1	48.1	25.1	25.1
060 - 072	995500A03	27.8	82.4	24.1	53.1	25.1	25.1

NOTE: \*Only the four corner brackets are needed on sizes 009-030.

## General Installation Information cont.

### Duct System

An air outlet collar is provided on vertical top flow units and all horizontal units to facilitate a duct connection (vertical bottom flow units have no collar). A flexible connector is recommended for discharge and return air duct connections on metal duct systems. Uninsulated duct should be insulated with a minimum of 1-inch duct insulation. Application of the unit to uninsulated ductwork in an unconditioned space is not recommended as the unit's performance will be adversely affected.

If the unit is connected to existing ductwork, check the duct system to ensure that it has the capacity to accommodate the air required for the unit application. If the duct is too small, as in the replacement of heating only systems, larger ductwork should be installed. All existing ductwork should be checked for leaks and repaired if necessary.

The duct system should be sized to handle the design airflow quietly and efficiently. To maximize sound attenuation of the unit blower, the supply and return plenums should include an internal duct liner of fiberglass or constructed of ductboard for the first few feet. On systems employing a sheet metal duct system, canvas connectors should be used between the unit and the ductwork. If air noise or excessive airflow is a problem, the blower speed can be changed.



**CAUTION:** Be sure to remove the shipping material from the blower discharge before connecting ductwork.

### Water Piping

The proper water flow must be provided to each unit whenever the unit operates. To assure proper flow, use pressure/temperature ports to determine the flow rate. These ports should be located at the supply and return water connections on the unit. The proper flow rate cannot be accurately set without measuring the water pressure drop through the refrigerant-to-water heat exchanger.

All source water connections on commercial units are fittings that accept a male pipe thread (MPT). Insert the connectors by hand, then tighten the fitting with a wrench to provide a leakproof joint. When connecting to an open loop (groundwater) system, thread any copper MPT fitting into the connector and tighten in the same manner as described above.

All source water connections on residential units are swivel piping fittings (see Figure 4) that accept a 1-inch male pipe thread (MPT). The swivel connector has a rubber gasket seal similar to a rubber hose gasket, which when mated to the flush end of any 1-inch threaded pipe provides a leak-free seal without the need for thread sealing tape or compound. Check to ensure that the rubber seal is in the swivel connector prior to attempting any connection. The rubber seals are shipped attached to the waterline. To make the connection to a ground loop system, mate the brass connector (supplied in CK4L connector kit) against the rubber gasket in the swivel connector and thread the female locking ring onto the pipe threads, while maintaining the brass connector in the desired direction. Tighten the connectors by hand, then gently snug the fitting with pliers to provide a leak-proof joint. When connecting to an open loop (ground water) system, thread any 1-inch MPT fitting (SCH80 PVC or copper) into the swivel connector and tighten in the same manner as noted above. The open and closed loop piping system should include pressure/temperature taps for serviceability.

Never use flexible hoses smaller than 1-inch inside diameter on the unit. Limit hose length to 10 feet per connection. Check carefully for water leaks.

**Figure 4: Swivel Connections (Residential Units)**

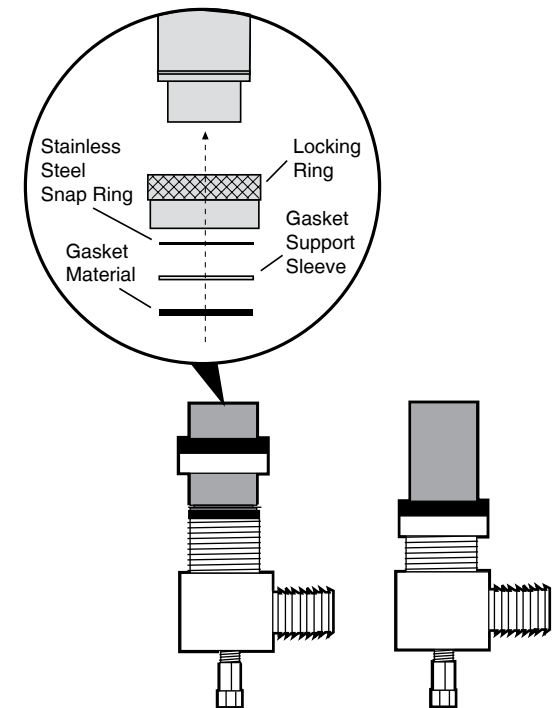

# General Installation Information cont.

## Water Quality

In ground water situations where scaling could be heavy or where biological growth such as iron bacteria will be present, a closed loop system is recommended. The heat exchanger coils in ground water systems may, over a period of time, lose heat exchange capabilities due to a buildup of mineral deposits inside. These can be cleaned, but only by a qualified service mechanic, as special solutions and pumping equipment are required. Desuperheater coils can likewise become scaled and possibly plugged. In areas with extremely hard water, the owner should be informed that the heat exchanger may require occasional flushing.

Units with cupronickel heat exchangers are recommended for open loop applications due to the increased resistance to build-up and corrosion, along with reduced wear caused by acid cleaning.

Material		Copper	90/10 Cupro-Nickel	316 Stainless Steel
pH	Acidity/Alkalinity	7 - 9	7 - 9	7 - 9
Scaling	Calcium and Magnesium Carbonate	(Total Hardness) less than 350 ppm	(Total Hardness) less than 350 ppm	(Total Hardness) less than 350 ppm
Corrosion	Hydrogen Sulfide	Less than .5 ppm (rotten egg smell appears at 0.5 PPM)	10 - 50 ppm	Less than 1 ppm
	Sulfates	Less than 125 ppm	Less than 125 ppm	Less than 200 ppm
	Chlorine	Less than .5 ppm	Less than .5 ppm	Less than .5 ppm
	Chlorides	Less than 20 ppm	Less than 125 ppm	Less than 300 ppm
	Carbon Dioxide	Less than 50 ppm	10 - 50 ppm	10 - 50 ppm
	Ammonia	Less than 2 ppm	Less than 2 ppm	Less than 20 ppm
	Ammonia Chloride	Less than .5 ppm	Less than .5 ppm	Less than .5 ppm
	Ammonia Nitrate	Less than .5 ppm	Less than .5 ppm	Less than .5 ppm
	Ammonia Hydroxide	Less than .5 ppm	Less than .5 ppm	Less than .5 ppm
	Ammonia Sulfate	Less than .5 ppm	Less than .5 ppm	Less than .5 ppm
	Total Dissolved Solids (TDS)	Less than 1000 ppm	1000-1500 ppm	1000-1500 ppm
Iron Fouling (Biological Growth)	LSI Index	*0.5 to *.05	*0.5 to *.05	*0.5 to *.05
	Iron, Fe <sup>2+</sup> (Ferrous) Bacterial Iron Potential	< .2ppm	< .2 ppm	< .2 ppm
	Iron Oxide	Less than 1 ppm. Above this level deposition will occur.	Less than 1 ppm. Above this level deposition will occur.	Less than 1 ppm. Above this level deposition will occur.
Erosion	Suspended Solids	Less than 10 ppm and filtered for max of 600 micron size	Less than 10 ppm and filtered for max of 600 micron size	Less than 10 ppm and filtered for max of 600 micron size
	Threshold Velocity (Fresh Water)	< 6 ft/sec	< 6 ft/sec	< 6 ft/sec

**Note:**

Grains = PPM divided by 17  
mg/l is equivalent to PPM



# General Installation Information cont.

## Freeze Protection

Set the freeze sensing switch SW2-2 on the printed circuit board for applications using a closed loop antifreeze solution to "LOOP". On applications using an open loop/ground water system (or closed loop no antifreeze), set this dip switch to "WELL", the factory default setting (see DIP Switch Settings table in the Microprocessor Control section).

## Condensate Drain

On vertical units, the internal condensate drain assembly consists of a drain tube which is connected to the drain pan, a 3/4-inch PVC female adapter and a flexible connecting hose. The female adapter may exit either the front or the side of the cabinet. The adapter should be glued to the field-installed PVC condensate piping. On vertical upflow units, a condensate hose is inside all cabinets as a trapping loop; therefore, an external trap is not necessary.

On horizontal units, a PVC stub is provided for condensate drain piping connection. An external trap is required (see below). If a vent is necessary, an open stand pipe may be applied to a tee in the field-installed condensate piping.

Figure 5: Horizontal Drain Connection

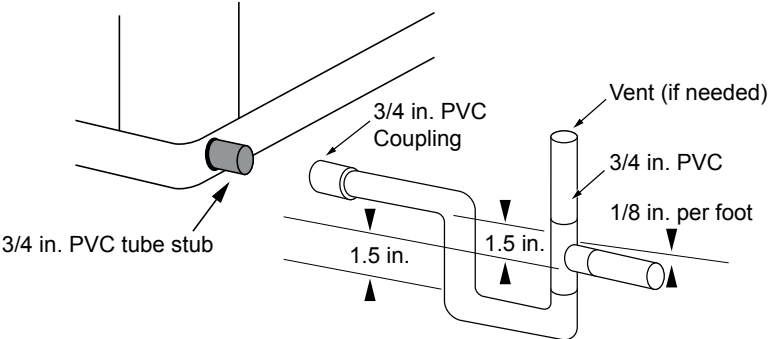
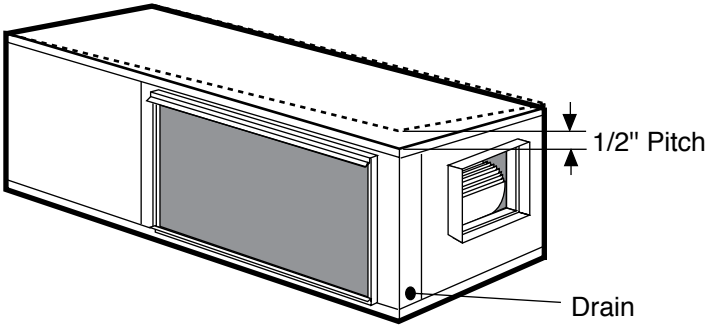

Figure 6: Unit Pitch for Drain



# Closed Loop Ground Source Systems

**Note:** For closed loop systems with antifreeze protection, set SW2-2 to the “loop” position (see DIP Switch Settings table in the Microprocessor Control section).

Once piping is completed between the unit, pumps and the ground loop (see figure below), final purging and charging of the loop is required. A flush cart (or a 1.5 HP pump minimum) is needed to achieve adequate flow velocity in the loop to purge air and dirt particles from the loop itself. Antifreeze solution is used in most areas to prevent freezing. Flush the system adequately to remove as much air as possible then pressurize the loop to a static pressure of 40-50 PSI (summer) or 50-75 PSI (winter). This is normally adequate for good system operation. Loop static pressure will fluctuate with the seasons. Pressures will be higher in the winter months than during the cooling season. This fluctuation is normal and should be considered when initially charging the system.

After pressurization, be sure to remove the plug in the end of the loop pump motor(s) (if applicable) to allow trapped air to be discharged and to ensure that the motor housing has been flooded. Ensure that the loop pumps provide adequate flow through the unit(s) by checking the pressure drop across the heat exchanger and comparing it to the unit capacity data in the specification catalog. 2.5 to 3 GPM of flow per ton of cooling capacity is recommended in earth loop applications.

**Figure 7: Closed Loop Ground Source Application**

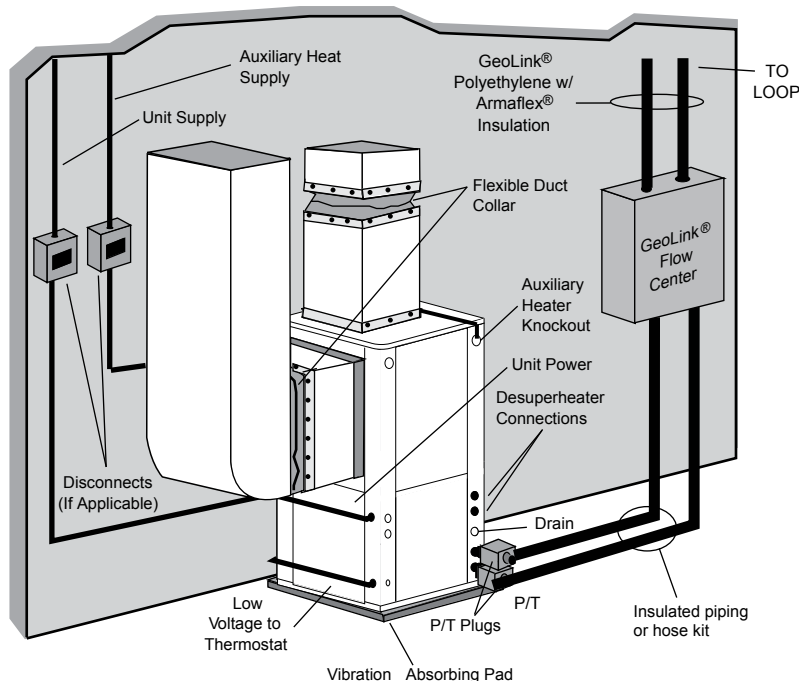

**Note:** Additional information can be found in Flow Center installation manual (IM1961) and Flush Cart manual (WFS302).

## Multiple Units on One Flow Center

When two units are connected to one loop pumping system, pump control is automatically achieved by connecting the SL terminals on connector P2 in both units with 2-wire thermostat wire. These terminals are polarity dependant (see Figure 8). The loop pump(s) may be powered from either unit, whichever is more convenient. If either unit calls, the loop pump(s) will automatically start. The use of two units on one flow center is generally limited to a total of 20 GPM capacity.

**Figure 8: Primary/Secondary Hook-up**

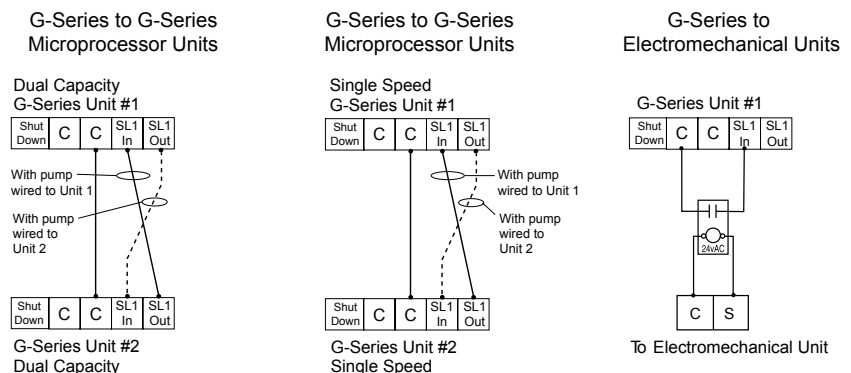

# Open Loop Ground Water Systems

Typical open loop piping is shown below. Always maintain water pressure in the heat exchanger by placing water control valves at the outlet of the unit to prevent mineral precipitation. Use a closed, bladder-type expansion tank to minimize mineral formation due to air exposure. Insure proper water flow through the unit by checking pressure drop across the heat exchanger and comparing it to the figures in unit capacity data tables in the specification catalog. 1.5-2 GPM of flow per ton of cooling capacity is recommended in open loop applications. Due to only minor differences in flow rate from low to high, only one solenoid valve should be used. The valve should be sized for full flow.

Discharge water from the unit is not contaminated in any manner and can be disposed of in various ways, depending on local codes, i.e. recharge well, storm sewer, drain field, adjacent stream or pond, etc. Most local codes forbid the use of sanitary sewer for disposal. Consult your local building and zoning departments to assure compliance in your area.

**Note:** For open loop/groundwater systems or systems that do not contain an antifreeze solution, set SW2-Switch #2 to the "WELL" position (see DIP Switch Settings table in the Microprocessor Control section). Slow opening/closing solenoid valves (type VM) are recommended to eliminate water hammer.

**Figure 9a: Open Loop Solenoid Valve Connection Option**

Typical quick operating external 24V water solenoid valve (type PPV100 or BPV100) wiring.

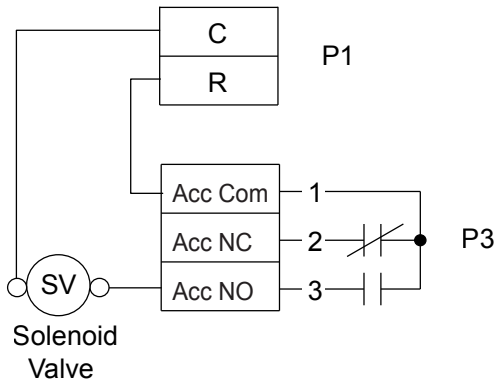

**Figure 9b: Open Loop Solenoid Valve Connection Option**

Typical slow operating external 24V water solenoid valve (type VM) wiring.

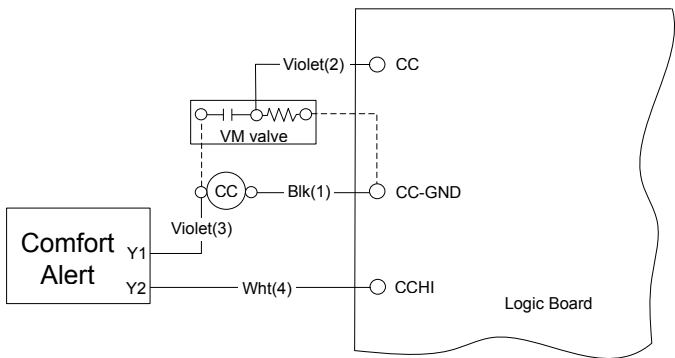

**Note:** SW2-3 should be in the Comp "ON" position.

**Figure 10: Open System - Groundwater Application**

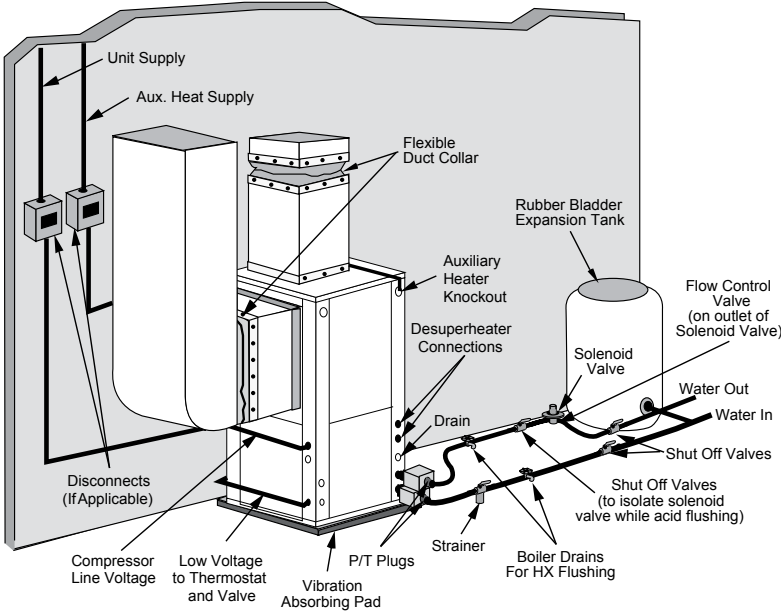

# Desuperheater Connections

To maximize the benefits of the desuperheater a minimum 50-gallon water heater is recommended. For higher demand applications, use an 80-gallon water heater or two 50-gallon water heaters connected in a series as shown below. Electric water heaters are recommended. Make sure all local electrical and plumbing codes are met for installing a desuperheater. Residential units with desuperheaters contain an internal circulator and fittings. Commercial units with a desuperheater do not include an internal circulator.

**Note:** Under certain conditions, GT dual capacity units operate with very low refrigerant discharge temperatures, producing little or no water heating capability. This scenario occurs when the unit is operating with cold entering source water (loop or well). Allowing the desuperheater pump to operate during these conditions actually removes heat from the DHW circulating through the unit. To overcome this, G Series unit microprocessors have been programmed to disengage the desuperheater pump during such conditions. (During low capacity cooling operation, the pump will operate only if the DHW temperature entering the unit is less than the liquid line temperature plus 35°F. During high capacity cooling operation, the pump will operate only if the DHW temperature is less than the liquid line temperature plus 60°F.) Using a preheat tank, as shown in Figure 12, will maximize desuperheater capabilities.

## Water Tank Preparation

To install a unit with desuperheater, follow these installation guidelines.

1. Turn off the power to the water heater.
2. Attach a water hose to the water tank drain connection and run the other end of the hose to an open drain or outdoors.
3. Close the cold water inlet valve to the water heater tank.
4. Drain the tank by opening the valve on the bottom of the tank, then open the pressure relief valve or hot water faucet.
5. Flush the tank by opening the cold water inlet valve to the water heater to free the tank of sediments. Close when draining water is clear.
6. Disconnect the garden hose and remove the drain valve from the water heater.
7. Refer to Plumbing Installation and Desuperheater Startup directions in the Desuperheater Connections section.

 **CAUTION: Elements will burn out if energized dry.**

**Figure 11: Typical Desuperheater Installation**

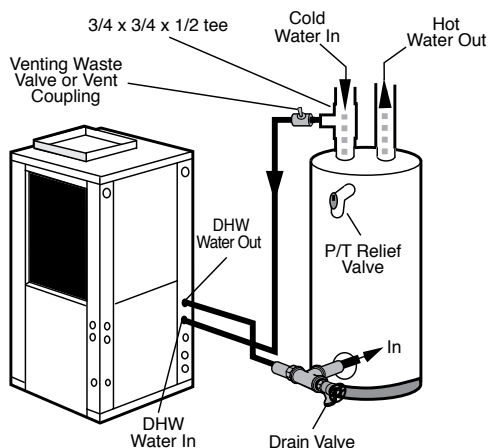

**Figure 12: Desuperheater Installation In Preheat Tank**

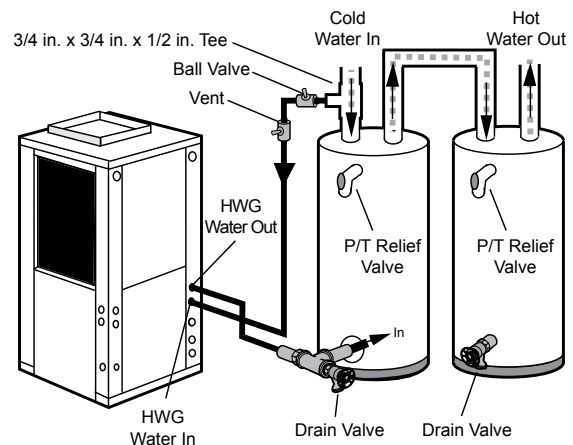

**Note:** This configuration maximizes desuperheater capability.

# Desuperheater Connections cont.

## Plumbing Installation

1. Inspect the dip tube in the water heater cold inlet for a check valve. If a check valve is present it must be removed or damage to the desuperheater circulator will occur.
2. Remove drain valve and fitting.
3. Thread the 3/4-inch NPT x 3-1/2-inch brass nipple into the water heater drain port.
4. Attach the center port of the 3/4-inch FPT tee to the opposite end of the brass nipple.
5. Attach the 1/2-inch copper to 3/4-inch NPT adaptor to the side of the tee closest to the unit.
6. Install the drain valve on the tee opposite the adaptor.
7. Run interconnecting tubing from the tee to DHW water out.
8. Cut the cold water "IN" line going to the water heater.
9. Insert the reducing solder tee in line with cold water "IN" line as shown.
10. Run interconnecting copper tubing between the unit DHW water "IN" and the tee (1/2-inch nominal). The recommended maximum distance is 50 feet.
11. To prevent air entrapment in the system, install a vent coupling at the highest point of the interconnecting lines.
12. Insulate all exposed surfaces of both connecting water lines with 3/8-inch wall closed cell insulation.

**Note:** All plumbing and piping connections must comply with local plumbing codes.

## Desuperheater Startup

1. Close the drain valve to the water heater.
2. Open the cold water supply to the tank.
3. Open a hot water faucet in the building to bleed air from the system. Close when full.
4. Open the pressure relief valve to bleed any remaining air from the tank, then close.
5. If so equipped, unscrew the indicator plug on the motor end of the pump until all air is purged from the pump, then tighten the plug. Use vent couplings to bleed air from the lines.
6. Carefully inspect all plumbing for water leaks and correct as required.
7. Before restoring electrical supply to the water heater, adjust the temperature setting on the tank.
  - On tanks with both upper and lower elements, the lower element should be turned down to the lowest setting, approximately 100°F. The upper element should be adjusted to 120°F to 130°F. Depending upon the specific needs of the customer, you may want to adjust the upper element differently.
  - On tanks with a single element, lower the thermostat setting to 120°F.
8. After the thermostat(s) is adjusted, replace the access cover and restore electrical supply to the water heater.
9. Make sure that any valves in the desuperheater water circulating circuit are open.
10. Turn on the unit to first stage heating.
11. The DHW pump should be running. When the pump is first started, open the inspection port (if equipped) until water dribbles out, then replace. Allow the pump to run for at least five minutes to ensure that water has filled the circulator properly. Be sure the switch for the DHW pump (SW4) is "ON". The DHW "OFF" LED on the unit should not be illuminated.
12. The temperature difference between the water entering and leaving the desuperheater should be 5°F to 15°F. The water flow should be approximately 0.4 GPM per ton of nominal cooling.
13. Allow the unit to heat water for 15 to 20 minutes to be sure operation is normal.



**CAUTION: Never operate the DHW circulating pump while dry. If the unit is placed in operation before the desuperheater piping is connected, be sure that the pump switch is set to the OFF position.**

# Electrical Connections

## General

Be sure the available power is the same voltage and phase as that shown on the unit serial plate. Line and low voltage wiring must be done in accordance with local codes or the National Electric Code, whichever is applicable.

## Unit Power Connection

Connect the incoming line voltage wires to L1 and L2 of the contactor as shown below for single-phase unit. Consult the Unit Electrical Data in the Specification Catalog for correct fuse sizes.

Control Box



Line Voltage 208-230/60/1 control box

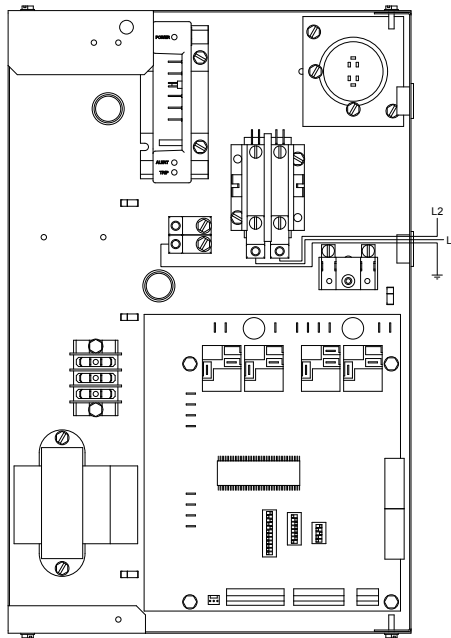

## Accessory Relay

A set of “dry” contacts has been provided to control accessory devices, such as water solenoid valves on open loop installations, electronic air cleaners, humidifiers, etc. This relay contact should be used only with 24 volt signals and not line voltage power. The relay has both normally open and normally closed contacts and can operate with either the fan or the compressor. Use DIP switch SW2-3 to cycle the relay with fan or compressor. The relay contacts are available on terminals #2 and #3 of P3.

## 208 Volt Operation

All G Series 208/230 units are factory wired for 230 volt operation. For 208 volt operation, the red and blue transformer wires must be switched on terminal strip PS.

# Electrical Connections cont.

## Pump Wiring

See Figure 14 for electrical connections from control box to pumps.

Figure 14: Pump Wiring 208-230/60/1

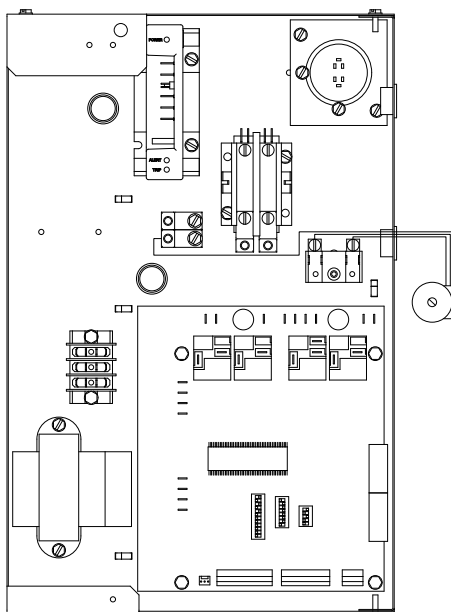

## Electronic Thermostat

Position the thermostat subbase against the wall so that it is level and the thermostat wires protrude through the middle of the subbase. Mark the position of the subbase mounting holes and drill holes with a 3/16-inch bit. Install supplied anchors and secure base to the wall. Thermostat wire must be 8-conductor, 18-AWG wire. Strip the wires back 1/4-inch (longer strip lengths may cause shorts) and insert the thermostat wires into the connector as shown. Tighten the screws to insure secure connections. The thermostat has the same type connectors, requiring the same wiring. See instructions enclosed in the thermostat for detailed installation and operation information.

Figure 15: Thermostat Wiring

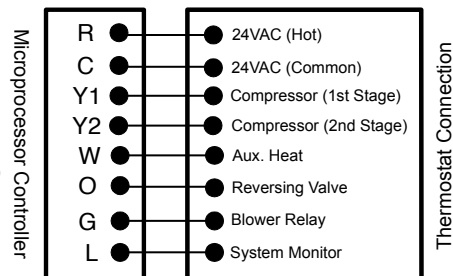

**Note:** DIP switch SW2-8 is required to be in the “OFF” position for the control to operate with FaultFlash or ComforTalk thermostats. SW2-8 in the “ON” position configures the control to operate with typical thermostats (continuous lockout signal). There must be a wire connecting Y2 on the microprocessor controller to 2nd stage compressor on the thermostat for proper operation.

## Auxiliary Heat Ratings

Model	KW		Stages	BTU/HR		Min CFM	G Series Compatibility			
	208V	230V		208V	230V		022	026 - 030	036 - 049	060 - 072
EAM(H)5	3.6	4.8	1	12,300	16,300	450	•	•		
EAM(H)8	5.7	7.6	2	19,400	25,900	550	•	•		
EAM(H)10	7.2	9.6	2	24,600	32,700	650		•		
EAL(H)10	7.2	9.6	2	24,600	32,700	1100			•	•
EAL(H)15	10.8	14.4	3	36,900	49,100	1250			•	•
EAL(H)15-3	10.8	14.4	3	36,900	49,100	1250			•	•
EAL(H)20	14.4	19.2	4	49,200	65,500	1500				•

# Electrical Data

## ECM2.3 Motor

Model	Rated Voltage	Voltage Min/Max	Compressor			Blower Motor FLA	Total Unit FLA	Min Circ Amp	Max Fuse/HACR
			MCC	RLA	LRA				
GS015	208-230/60/1	197/253	na	6.2	29.0	4.0	10.2	11.8	15
	265/60/1	238/292	na	5.6	28.0	4.1	9.7	11.1	15
GS018	208-230/60/1	197/253	na	8.4	33.5	4.0	12.4	14.5	20
	265/60/1	238/292	na	7.3	28.0	4.1	11.4	13.2	20
GS022	208-230/60/1	197/253	14.0	9.0	48.0	4.0	13.0	15.2	20
	265/60/1	238/292	13.0	8.3	40.0	4.1	12.4	14.5	20
GS030	208-230/60/1	197/253	20.0	12.8	58.3	4.0	16.8	20.0	30
	265/60/1	238/292	14.9	9.5	87.0	4.1	13.6	16.0	25
GS036	208-230/60/1	197/253	22.0	14.1	73.0	4.0	18.1	21.6	35
	265/60/1	238/292	17.5	11.2	60.0	4.1	15.3	18.1	25
	208-230/60/3	187/253	13.9	8.9	58.0	4.0	12.9	15.1	20
	460/60/3	414/506	6.5	4.2	28.0	4.1	8.3	9.4	10
GS036*	208-230/60/1	197/253	22.0	14.1	73.0	7.0	21.1	24.6	35
	265/60/1	238/292	17.5	11.2	60.0	6.9	18.1	20.9	30
	208-230/60/3	187/253	13.9	8.9	58.0	7.0	15.9	18.1	25
	460/60/3	414/506	6.5	4.2	28.0	6.9	11.1	12.2	15
GS042	208-230/60/1	197/253	26.0	16.6	79.0	4.0	20.6	24.8	40
	208-230/60/3	187/253	16.3	10.4	73.0	4.0	14.4	17.0	25
	460/60/3	414/506	9.0	5.8	38.0	4.1	9.9	11.3	15
GS042*	208-230/60/1	197/253	26.0	16.6	79.0	7.0	23.6	27.8	40
	208-230/60/3	187/253	16.3	10.4	73.0	7.0	17.4	20.0	30
	460/60/3	414/506	9.0	5.8	38.0	6.9	12.7	14.1	15
GS048	208-230/60/1	197/253	31.0	19.8	109.0	4.0	23.8	28.8	45
	208-230/60/3	187/253	21.2	13.6	83.1	4.0	17.6	21.0	30
	460/60/3	414/506	9.5	6.1	41.0	4.1	10.2	11.7	15
GS048*	208-230/60/1	197/253	31.0	19.8	109.0	7.0	26.8	31.8	50
	208-230/60/3	187/253	21.2	13.6	83.1	7.0	20.6	24.0	35
	460/60/3	414/506	9.5	6.1	41.0	6.9	13.0	14.5	20
GS060	208-230/60/1	197/253	41.2	26.4	134.0	7.0	33.4	40.0	60
	208-230/60/3	187/253	24.9	15.9	110.0	7.0	22.9	26.9	40
	460/60/3	414/506	12.1	7.7	52.0	6.9	14.6	16.6	20
GS070	208-230/60/1	197/253	47.0	30.1	158.0	7.0	37.1	44.6	70
	208-230/60/3	187/253	32.0	20.5	155.0	7.0	27.5	32.6	50
	460/60/3	414/506	15.0	9.6	75.0	6.9	16.5	18.9	25
GT026	208-230/60/1	197/253	16.0	10.2	52.0	4.0	14.2	16.8	25
GT038	208-230/60/1	197/253	26.0	16.6	82.0	4.0	20.6	24.8	40
	208-230/60/3	187/253	17.4	11.1	58.0	4.0	15.1	17.9	25
	460/60/3	414/506	7.0	4.5	29.0	4.1	8.6	9.7	10
GT038*	208-230/60/1	197/253	26.0	16.6	82.0	7.0	23.6	27.8	40
	208-230/60/3	187/253	17.4	11.1	58.0	7.0	18.1	20.9	30
	460/60/3	414/506	7.0	4.5	29.0	6.9	11.4	12.5	15
GT049	208-230/60/1	197/253	33.0	21.1	96.0	4.0	25.1	30.4	50
	208-230/60/3	187/253	21.0	13.4	88.0	4.0	17.4	20.8	30
	460/60/3	414/506	10.0	6.4	41.0	4.1	10.5	12.1	15
GT049*	208-230/60/1	197/253	33.0	21.1	96.0	7.0	28.1	33.4	50
	208-230/60/3	187/253	21.0	13.4	88.0	7.0	20.4	23.8	35
	460/60/3	414/506	10.0	6.4	41.0	6.9	13.3	14.9	20
GT064	208-230/60/1	197/253	40.0	25.6	118.0	7.0	32.6	39.0	60
	208-230/60/3	187/253	27.5	17.6	123.0	7.0	24.6	29.0	45
	460/60/3	414/506	14.0	9.0	62.0	6.9	15.9	18.1	25
GT072	208-230/60/1	197/253	42.5	27.2	150.0	7.0	34.2	41.0	60

HACR circuit breaker in USA only  
the compressor data for 265 V NS022 is preliminary:

\*With optional 1 HP ECM2.3 motor

3/24/2007



# Electrical Data cont.

## PSC Motor

Model	Rated Voltage	Voltage Min/Max	Compressor			Blower Motor FLA	Total Unit FLA	Min Circ Amp	Max Fuse/HACR
			MCC	RLA	LRA				
GS009	208-230/60/1	197/253	N/A	4.8	21.0	0.6	5.4	6.6	10
	265/60/1	238/292	N/A	4.3	22.0	0.6	4.9	6.0	10
GS012	208-230/60/1	197/253	N/A	5.9	25.0	0.6	6.5	8.0	10
	265/60/1	238/292	N/A	5.3	22.0	0.6	5.9	7.2	10
GS015	208-230/60/1	197/253	N/A	6.2	29.0	1.1	7.3	8.9	15
	265/60/1	238/292	N/A	5.6	28.0	1.0	6.6	8.0	10
GS018	208-230/60/1	197/253	N/A	8.4	33.5	1.1	9.5	11.6	20
	265/60/1	238/292	N/A	7.3	28.0	1.0	8.3	10.1	15
GS022	208-230/60/1	197/253	14.0	9.0	48.0	1.2	10.2	12.4	20
	265/60/1	238/292	13.0	8.3	40.0	1.1	9.4	11.5	15
GS022**	208-230/60/1	197/253	14.0	9.0	48.0	1.5	10.5	12.7	20
	265/60/1	238/292	13.0	8.3	40.0	2.0	10.3	12.4	20
GS030	208-230/60/1	197/253	20.0	12.8	58.3	1.5	14.3	17.5	30
GS030**	208-230/60/1	197/253	20.0	12.8	58.3	2.2	15.0	18.2	30
	265/60/1	238/292	14.9	9.5	87.0	2.0	11.5	13.9	20
GS036	208-230/60/1	197/253	22.0	14.1	73.0	2.8	16.9	20.4	30
	265/60/1	238/292	17.5	11.2	60.0	2.0	13.2	16.0	25
	208-230/60/3	187/253	13.9	8.9	58.0	2.8	11.7	13.9	20
	460/60/3	414/506	6.5	4.2	28.0	1.4	5.6	6.7	10
GS036**	208-230/60/1	197/253	22.0	14.1	73.0	3.5	17.6	21.1	35
	265/60/1		Not Available						
	208-230/60/3	187/253	13.9	8.896	58.0	3.5	12.396	14.6	20
	460/60/3	414/506	6.5	4.2	28.0	1.8	6.0	7.1	10
GS042	208-230/60/1	197/253	26.0	16.6	79.0	3.5	20.1	24.3	40
	208-230/60/3	187/253	16.3	10.4	73.0	3.5	13.9	16.5	25
	460/60/3	414/506	9.0	5.8	38.0	1.8	7.6	9.0	10
	575/60/3	517/633	5.9	3.8	36.5	1.4	5.2	6.1	10
GS042**	208-230/60/1	197/253	26.0	16.6	79.0	4.6	21.2	25.4	40
	208-230/60/3	187/253	16.3	10.4	73.0	4.6	15.0	17.6	25
	460/60/3	414/506	9.0	5.8	38.0	2.3	8.1	9.5	15
	575/60/3	517/633	5.9	3.8	36.5	1.9	1.9	6.6	10
GS048	208-230/60/1	197/253	31.0	19.8	109.0	3.5	23.3	28.3	45
	208-230/60/3	187/253	21.2	13.6	83.1	3.5	17.1	20.5	30
	460/60/3	414/506	9.5	6.1	41.0	1.8	7.9	9.4	15
	575/60/3	517/633	7.8	5.0	34.0	1.4	6.4	7.6	10
GS048**	208-230/60/1	197/253	31.0	19.8	109.0	4.6	24.4	29.4	45
	208-230/60/3	187/253	21.2	13.6	83.1	4.6	18.2	21.6	35
	460/60/3	414/506	9.5	6.1	41.0	2.3	8.4	9.9	15
	575/60/3	517/633	7.8	5.0	34.0	1.9	6.9	8.1	10
GS060	208-230/60/1	197/253	41.2	26.4	134.0	5.9	32.3	38.9	60
	208-230/60/3	187/253	24.9	15.9	110.0	5.9	21.8	25.8	40
	460/60/3	414/506	12.1	7.7	52.0	3.0	10.7	12.7	20
	575/60/3	517/633	8.9	5.7	38.9	1.9	7.6	9.0	10
GS070	208-230/60/1	197/253	47.0	30.1	158.0	5.9	36.0	43.5	70
	208-230/60/3	187/253	32.0	20.5	155.0	5.9	26.4	31.5	50
	460/60/3	414/506	15.0	9.6	75.0	3.0	12.6	15.0	20
	575/60/3	517/633	11.9	7.6	54.0	1.9	9.5	11.4	15

HACR circuit breaker in USA only  
the compressor data for 265 V NS022 is preliminary:  
\*\*With optional High-static PSC motor

3/24/2007

# Blower Performance Data - PSC

## Standard PSC Motor

Model	Blower Spd	Blower Size	Motor	Airflow (cfm) at External Static Pressure (in. wg)															
				0	0.05	0.10	0.15	0.20	0.25	0.30	0.35	0.40	0.45	0.50	0.60	0.70	0.80	0.90	1.00
GS009	H	6 x 8	1/10	480	450	440	420	410	380	360	340	330	310	300	-	-	-	-	-
	MH			440	410	400	380	370	350	330	310	300	280	270	-	-	-	-	-
	ML*			395	370	360	340	330	310	290	280	270	250	240	-	-	-	-	-
	L			325	310	300	280	270	250	240	230	220	210	200	-	-	-	-	-
GS012	H	6 x 8	1/10	480	450	440	420	410	380	360	340	330	310	300	-	-	-	-	-
	MH			440	410	400	380	370	350	330	310	300	280	270	-	-	-	-	-
	ML			395	370	360	340	330	310	290	280	270	250	240	-	-	-	-	-
	L			325	310	300	280	270	250	240	230	220	210	200	-	-	-	-	-
GS015	H	9 x 7	1/6	845	835	825	815	800	790	775	755	735	710	680	565	-	-	-	-
	M			735	730	725	715	705	700	690	675	660	630	600	485	-	-	-	-
	L			620	615	610	605	600	590	580	565	550	520	490	-	-	-	-	-
GS018	H	9 x 7	1/6	845	835	825	815	800	790	775	755	735	710	680	565	-	-	-	-
	M			735	730	725	715	705	700	690	675	660	630	600	485	-	-	-	-
	L			620	615	610	605	600	590	580	565	550	520	490	-	-	-	-	-
GS022	H	9 x 7	1/5	1110	1095	1080	1065	1045	1020	995	970	945	915	880	810	-	-	-	-
	M			850	845	835	825	815	805	795	775	755	735	715	-	-	-	-	-
	L			750	745	740	735	725	715	700	685	670	650	630	-	-	-	-	-
GS030	H	9 x 7	1/3	1290	1270	1245	1220	1190	1160	1125	1090	1055	1020	985	880	760	-	-	-
	M			1100	1090	1075	1060	1045	1020	995	970	940	910	875	785	625	-	-	-
	L			910	905	900	895	885	875	865	850	835	810	780	710	560	-	-	-
GS036	H	9 x 7	1/2	1665	1640	1610	1580	1550	1515	1480	1450	1415	1315	1215	1090	980	-	-	-
	M			1465	1445	1425	1400	1375	1350	1325	1260	1190	1140	1090	990	890	-	-	-
	L			1130	1115	1100	1090	1075	1035	995	965	930	895	860	795	730	-	-	-
GS042	H	10 x 10	1/2	2010	1975	1940	1905	1870	1825	1780	1735	1690	1640	1590	1470	1210	-	-	-
	M			1670	1650	1630	1610	1590	1560	1530	1495	1460	1425	1390	1190	1080	-	-	-
	L			1220	1215	1210	1205	1200	1180	1160	1130	1100	1060	1020	930	-	-	-	-
GS048	H	10 x 10	1/2	2010	1975	1940	1905	1870	1825	1780	1735	1690	1640	1590	1470	1210	-	-	-
	M			1670	1650	1630	1610	1590	1560	1530	1495	1460	1425	1390	1190	1080	-	-	-
	L			1220	1215	1210	1205	1200	1180	1160	1130	1100	1060	1020	930	-	-	-	-
GS060	H	11 x 10	1	2430	2400	2365	2330	2290	2255	2215	2180	2140	2095	2045	1945	1835	1715	1510	1330
	M			2265	2235	2205	2175	2145	2110	2070	2035	2000	1960	1915	1825	1730	1605	1440	1260
	L			2075	2050	2020	1995	1965	1940	1915	1885	1850	1820	1785	1720	1610	1505	1335	1175
GS070	H	11 x 10	1	2430	2400	2365	2330	2290	2255	2215	2180	2140	2095	2045	1945	1835	1715	1510	1330
	M			2265	2235	2205	2175	2145	2110	2070	2035	2000	1960	1915	1825	1730	1605	1440	1260
	L			2075	2050	2020	1995	1965	1940	1915	1885	1850	1820	1785	1720	1610	1505	1335	1175

Factory settings are in Bold

Air flow values are with dry coil and standard filter

For wet coil performance first calculate the face velocity of the air coil (Face Velocity [fpm] = Airflow [cfm] / Face Area [sq ft]).

Then for velocities of 200 fpm reduce the static capability by 0.03 in. wg, 300 fpm by 0.08 in. wg, 400 fpm by 0.12in. wg. and 500 fpm by 0.16 in. wg.

2/15/08

## Optional High Static PSC Motor

Model	Blower Spd	Blower Size	Motor HP	Airflow (cfm) at External Static Pressure (in. wg)															
				0	0.05	0.10	0.15	0.20	0.25	0.30	0.35	0.40	0.45	0.50	0.60	0.70	0.80	0.90	1.00
GS022	H	9 x 7	1/3	1290	1270	1245	1220	1190	1160	1125	1090	1055	1020	985	880	760	-	-	-
	M			1100	1090	1075	1060	1045	1020	995	970	940	910	875	785	625	-	-	-
	L			910	905	900	895	885	875	865	850	835	810	780	710	560	-	-	-
GS030	H	9 x 7	1/2	1365	1340	1325	1305	1280	1250	1215	1180	1140	1100	1055	960	850	-	-	-
	M			1040	1040	1035	1030	1020	1005	990	970	945	915	885	810	735	-	-	-
	L			880	880	880	880	875	870	860	840	820	800	775	730	480	-	-	-
GS036	H	9 x 7	1/2	1930	1905	1875	1840	1805	1765	1725	1680	1635	1530	1425	1270	1150	1025	-	-
	M			1635	1620	1600	1580	1555	1530	1505	1465	1425	1335	1240	1135	1035	775	-	-
	L			1230	1230	1225	1215	1200	1165	1130	1095	1060	1035	1005	935	795	675	-	-
GS042	H	10 x 10	3/4	2115	2075	2035	1980	1920	1900	1880	1840	1795	1730	1660	1390	1225	1070	-	-
	M			2005	1980	1950	1910	1865	1815	1765	1725	1685	1585	1485	1315	1140	1025	-	-
	L			1860	1835	1805	1780	1750	1715	1675	1635	1590	1540	1490	1260	1115	980	-	-
GS048	H	10 x 10	3/4	2115	2075	2035	1980	1920	1900	1880	1840	1795	1730	1660	1390	1225	1070	-	-
	M			2005	1980	1950	1910	1865	1815	1765	1725	1685	1585	1485	1315	1140	1025	-	-
	L			1860	1835	1805	1780	1750	1715	1675	1635	1590	1540	1490	1260	1115	980	-	-

Factory settings are in Bold

High-Static option not available for GS060 and GS070

\* - Denotes setting for 265 V operation.

Air flow values are with dry coil and standard filter

For wet coil performance first calculate the face velocity of the air coil (Face Velocity [fpm] = Airflow [cfm] / Face Area [sq ft]).

Then for velocities of 200 fpm reduce the static capability by 0.03 in. wg, 300 fpm by 0.08 in. wg, 400 fpm by 0.12in. wg. and 500 fpm by 0.16 in. wg.

2/15/08

# Setting Fan Speed - PSC



**CAUTION: Disconnect all power before performing this operation.**

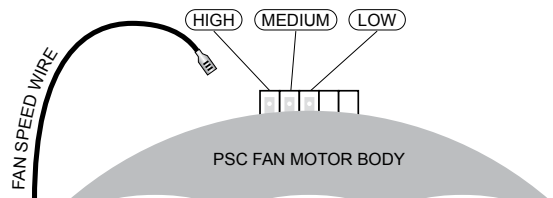

# Blower Performance Data - ECM2.3

## Single Speed

MODEL	MAX ESP	AIR FLOW DIP SWITCH SETTINGS											
		1	2	3	4	5	6	7	8	9	10	11	12
015	0.50	300 L	400	500 M	600 H	700							
018	0.50	300	400 L	500	600 M	700 H	800						
022	0.50		400	500 L	600 M	700	800 H	900	1000	1100	1200		
030	0.50		400	500 L	600	700 M	800	900 H	1000	1100	1200		
036	0.50	650	750	850 L	1000	1100 M	1200	1300 H	1400	1500			
36 w/1hp*	0.75	800	1000 L	1100 M	1300 H	1500	1600	1800					
042	0.50	650	800	900 L	1050	1150 M	1250	1350 H	1450	1550			
42 w/1hp*	0.75	800	900 L	1000	1200 M	1400 H	1600	1700	1850	2000	2200	2300	2400
048	0.50	650	800	900	1050 L	1150	1250	1350 M	1450 H	1550			
48 w/1hp*	0.75	800	900	1000 L	1200	1400 M	1600 H	1700	1850	2000	2200	2300	2400
060	0.75	800	950	1100 L	1300	1500 M	1750	1950 H	2100	2300			
070	0.75	800	950	1100 L	1300	1500	1750 M	1950 H	2100	2300			

Factory settings are at recommended L-M-H DIP switch locations  
M-H settings MUST be located within boldface CFM range  
Lowest and Highest DIP switch settings are assumed to be L and H respectively

CFM is controlled within ±5% up to the maximum ESP  
Max ESP includes allowance for wet coil and standard filter

5/25/07

## Dual Capacity

MODEL	MAX ESP	AIR FLOW DIP SWITCH SETTINGS											
		1	2	3	4	5	6	7	8	9	10	11	12
026	0.50		400	500 L	600	700 M	800	900 H	1000	1100	1200		
038	0.50	650	750 L	850	1000	1100 M	1200	1300 H	1400	1500			
38 w/1hp*	0.75	800	1000 L	1100 M	1300 H	1500	1600	1800					
049	0.50	650	800 L	900	1050	1150	1250	1350 M	1450 H	1550			
49 w/1hp*	0.75	800	900 L	1000	1200	1400 M	1600 H	1700	1850	2000	2200	2300	2400
064	0.75	800	950 L	1100	1300	1500 M	1750	1950 H	2100	2300			
072	0.75	800	950 L	1100	1300	1500	1750 M	1950 H	2100	2300			

Factory settings are at recommended L-M-H DIP switch locations  
M-H settings MUST be located within boldface CFM range  
Lowest and Highest DIP switch settings are assumed to be L and H respectively

CFM is controlled within ±5% up to the maximum ESP  
Max ESP includes allowance for wet coil and standard filter

5/30/06

A 12-position DIP switch package on the control allows the airflow levels to be set for low, medium, and high speed when using the ECM2.3 blower motor. Only three of the DIP switches can be in the "on" position.

- The first "on" switch (the lowest position number) determines the low speed blower setting.
- The second "on" switch determines the medium speed blower setting.
- The third "on" switch determines the high speed blower setting.

The example to the right shows SW1 on the control board configured for the following 042 airflow settings.

- Low Speed Blower: 900 CFM
- Medium Speed Blower: 1150 CFM
- High Speed Blower: 1450 CFM

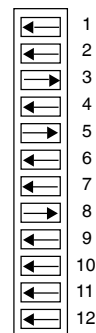

## Setting Fan Speed

ECM2 fan motors have a 12-speed selector dip switch on the logic board (SW1) and are factory set for optimum performance. To change speeds, select the appropriate speeds on dip switch SW1. Consult the ECM2 fan performance table below for specific airflow and switch information.



**CAUTION: Disconnect all power before performing this operation.**

# Vertical Dimensional Data

## Top Air Discharge

**Legend**  
 AP = Alternate Service Panel  
 BP = Blower Service Panel  
 CP = Control Access Panel  
 CMP = Compressor Service Panel

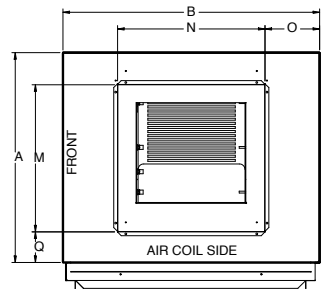

TOP VIEW - RIGHT RETURN

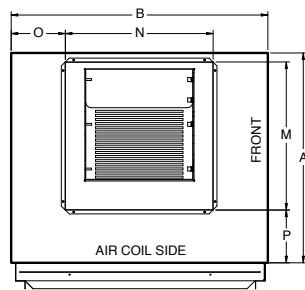

TOP VIEW - LEFT RETURN

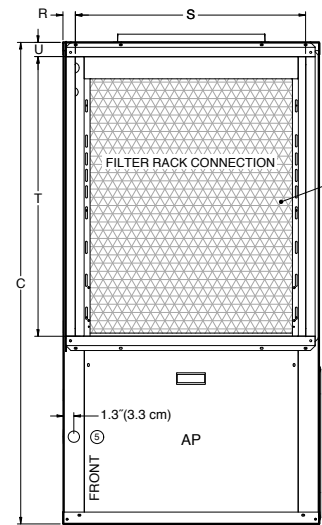

RIGHT VIEW - RIGHT RETURN

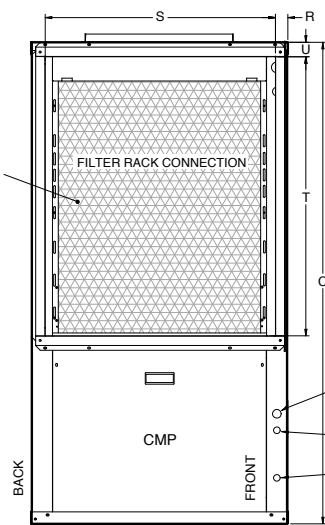

LEFT VIEW - LEFT RETURN

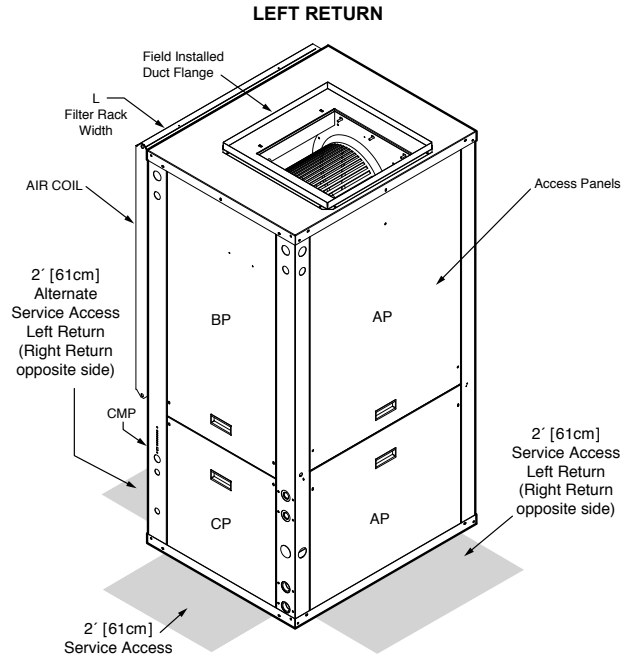

2' [61cm] Service Access

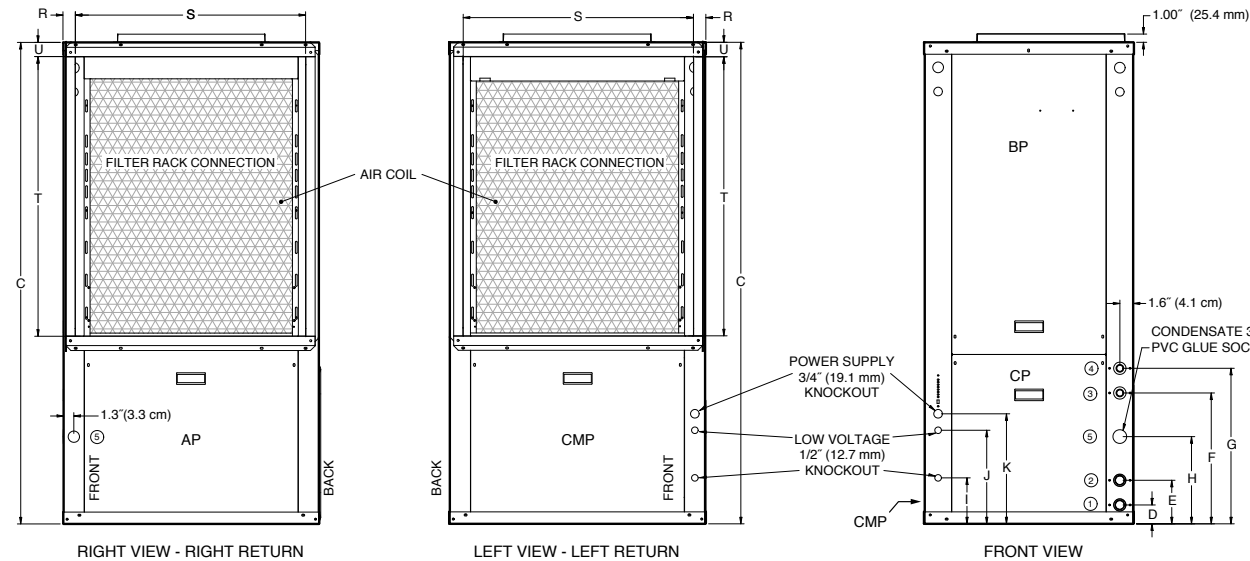

FRONT VIEW

Vertical Models	Overall Cabinet			Water Connections							Electrical Knockouts			Filter Rack Width	Discharge Connection duct flange installed (±0.10 in)					Return Connection using std deluxe filter rack (±0.10 in)				
	A	B	C	1	2	3	4	5	I	J	K	M	N		O	P	Q	R	S	T	U			
	Width	Depth	Height*	D	E	F	G	H	1/2" cond Low Voltage	1/2" cond Ext Pump	3/4" cond Power Supply	Supply Width	Supply Depth					Return Depth	Return Depth	Return Height				
009-012	in.	22.2	22.5	34.5	2.3	5.3	11.9	14.9	8.6	1/2"	1/2"	3.8	9.7	11.7	2.2	10.0	10.0	6.1	8.8	11.8	2.4	18.1	14.2	1.7
	cm.	56.4	57.2	87.6	5.9	13.5	30.2	37.8	21.8	12.7 mm	12.7 mm	9.7	24.6	29.7	5.5	25.4	25.4	15.5	22.4	30.0	6.1	46.0	36.1	4.4
015-018	in.	22.5	26.5	39.4	2.3	5.3	13.4	16.4	9.6	3/4"	1/2"	5.1	10.8	12.8	2.2	14.0	14.0	6.3	7.8	5.9	2.0	22.0	18.0	2.0
	cm.	57.2	67.3	100.1	5.8	13.5	34.0	41.7	24.3	19.05 mm	12.7 mm	13.0	27.4	32.5	5.5	35.6	35.6	16.0	19.8	14.9	5.1	55.9	45.7	5.1
022-030	in.	22.5	26.5	48.4	2.3	7.3	13.4	16.4	10.3	3/4"	1/2"	5.1	10.8	12.8	2.2	14.0	14.0	6.3	7.8	5.9	2.3	22.0	26.0	2.0
	cm.	57.2	67.3	122.9	5.8	18.5	34.0	41.7	26.2	19.05 mm	12.7 mm	13.0	27.4	32.5	5.5	35.6	35.6	16.0	19.8	15.0	5.8	55.9	66.0	5.1
036-072	in.	25.5	31.2	58.4	2.3	7.3	15.9	18.9	10.6	1"	1/2"	6.5	12.3	17.9	2.2	18.0	18.0	6.9	6.5	3.7	1.7	28.1	34.0	2.0
	cm.	64.8	79.2	148.3	5.8	18.5	40.4	48.0	26.9	25.4 mm	12.7 mm	16.5	31.2	45.5	5.5	45.7	45.7	17.5	16.5	9.4	4.3	71.4	86.4	5.1

Condensate is 3/4 in. PVC female glue socket and is switchable from side to front

Vertical unit shipped with 1 in. (field adjustable to 2 in.) duct collar/filter rack extending from unit 3.25 in. and is suitable for duct connection.

Discharge flange is field installed and extends 1 in. (25.4 mm) from cabinet

Residential cabinets are supplied with 1 in. swivel on loop water lines and 1/2 in. I.D. female sweat connections on HWG water lines.

Rev: 03/11/10

# Vertical Dimensional Data cont.

## Bottomflow

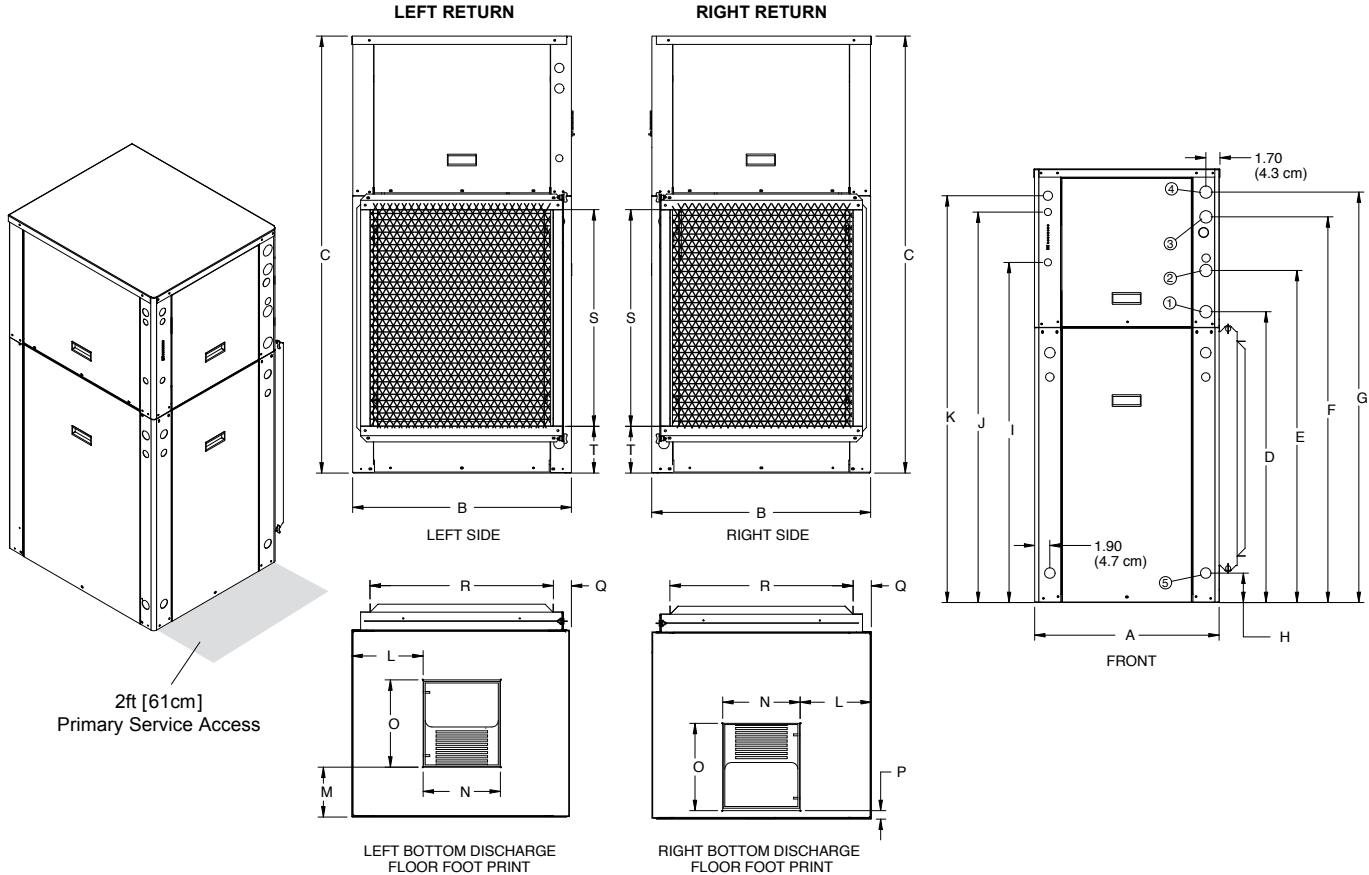

Bottomflow Models	Overall Cabinet			Water Connections							Electrical Knockouts			Discharge Connection duct flange installed (±0.10 in)					Return Connection using std deluxe filter rack (±0.10 in)				
	A	B	C	1	2	3	4	5	Loop Water FPT	HWG FPT	I	J	K	L	M	N	O	P	Q	R	S	T	
	Width	Depth	Height	D In	E Out	F HWG In	G HWG Out	H Condensate			1/2" cond Low Voltage	1/2" cond Ext Pump	3/4" cond Power Supply	Supply Width	Supply Depth	Return Depth	Return Height						
022-030	in. cm.	22.5 57.2	26.5 67.3	52.5 133.4	35.3 89.7	40.2 102.1	46.7 118.6	49.7 126.2	3.6 9.1	3/4 in. 19.1 mm	1/2 in. 12.7 mm	39.2 99.6	47.0 119.4	49.0 124.5	8.6 21.8	6.0 15.2	9.3 23.6	10.5 26.7	1.0 2.5	2.2 5.6	22.2 56.4	26.0 66.0	5.6 14.2
036-072	in. cm.	25.5 64.8	31.5 80.0	62.5 158.8	43.4 110.2	48.4 122.9	57.0 144.8	60.0 152.4	3.6 9.1	1 in. 25.4 mm	1/2 in. 12.7 mm	47.2 119.8	54.9 139.5	56.9 144.6	9.1 23.1	4.8 12.2	13.4 34.0	13.6 34.5	1.5 3.8	1.6 4.1	28.1 71.4	34.0 86.4	5.6 14.2

Condensate is 3/4 in. PVC female glue socket and is switchable from side to front  
 Vertical bottomflow unit shipped with deluxe 1 in. (field adjustable to 2 in.) duct collar/filter rack extending from unit 3.25 in. and is suitable for duct connection.  
 036-072 Bottomflow units use 30 in. x 36 in. air filter

Residential cabinets are supplied with 1 in. swivel on loop water lines and 1/2 in. I.D. female sweat connections on HWG water lines.

Rev.: 03/11/10

# Vertical Dimensional Data cont.

## Rear Air Discharge

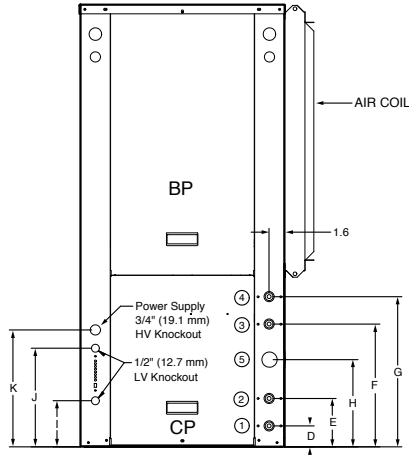

FRONT VIEW  
Right Return

**Legend**  
 AP = Alternate Service Panel  
 BP = Blower Service Panel  
 CP = Control Access Panel  
 CMP = Compressor Service Panel

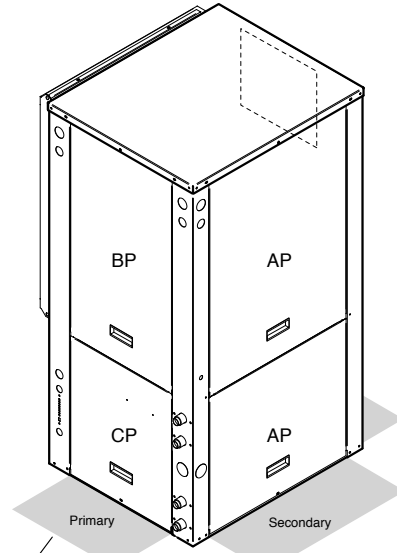

2ft [61cm]  
Service Access Points

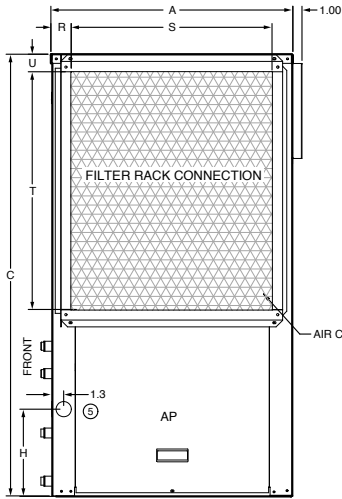

SIDE VIEW  
Right Return

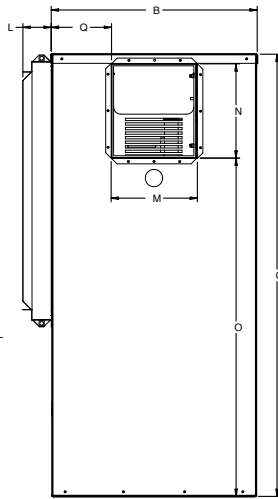

REAR VIEW  
Right Return

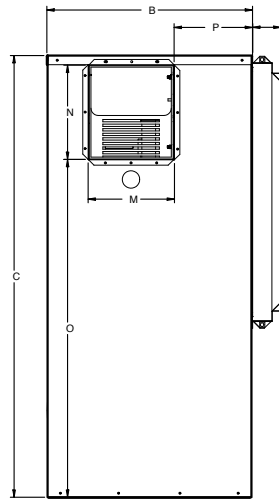

REAR VIEW  
Left Return

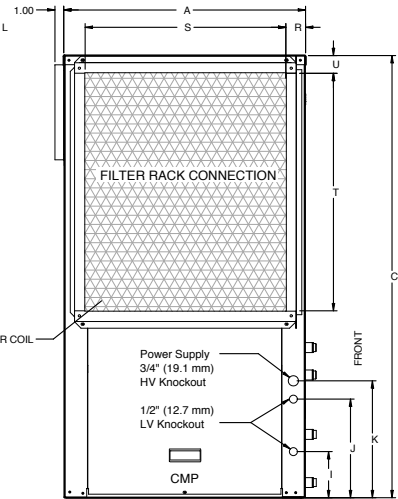

SIDE VIEW  
Left Return

Vertical Models	Overall Cabinet			Water Connections							Electrical Knockouts				Filter Rack Width	Discharge Connection duct flange installed (±0.10 in)					Return Connection using std deluxe filter rack (±0.10 in)				
	A	B	C	1	2	3	4	5	I	J	K	KK	M	N		O	P	Q	R	S	T	U			
	Width	Depth	Height*	In	Out	HWG In	HWG Out	Condensate	1/2" cond Low Voltage	1/2" cond Ext Pump	3/4" cond Power Supply	3/4" cond Power Supply	Supply Width	Supply Depth					Return Depth	Return Height					
022-030	in. cm.	22.3 56.6	26.5 67.3	48.4 122.9	2.3 5.8	7.3 18.5	13.4 34.0	16.4 41.7	10.4 26.4	3/4" 19.05 mm	1/2" 12.7 mm	5.1 13.0	10.8 27.4	12.8 32.5	N/A N/A	2.2 5.5	9.5 24.1	10.4 26.4	37.0 94.0	8.5 21.6	6.5 16.5	2.1 5.3	22.0 55.9	26.0 66.0	2.0 5.1
036-072	in. cm.	25.5 64.8	31.2 79.2	58.4 148.3	2.3 5.8	7.3 18.5	15.9 40.4	18.9 48.0	11.6 29.5	1" 25.4 mm	1/2" 12.7 mm	5.6 14.2	11.4 29.0	13.4 34.0	3.7 9.4	2.2 5.5	13.3 33.8	13.6 34.5	43.4 110.2	9.1 23.1	8.1 20.6	1.6 4.1	28.1 71.4	34.0 86.4	1.7 4.3

Condensate is 3/4 in. PVC female glue socket and is switchable from side to front

Vertical unit shipped with 1 in. (field adjustable to 2 in.) duct collar/filter rack extending from unit 3.25 in. and is suitable for duct connection.

Discharge flange is field installed and extends 1 in. (25.4 mm) from cabinet

Residential cabinets are supplied with 1 in. swivel on loop water lines and 1/2 in. I.D. female sweat connections on HWG water lines.

Rev: 03/11/10

# Horizontal Dimensional Data

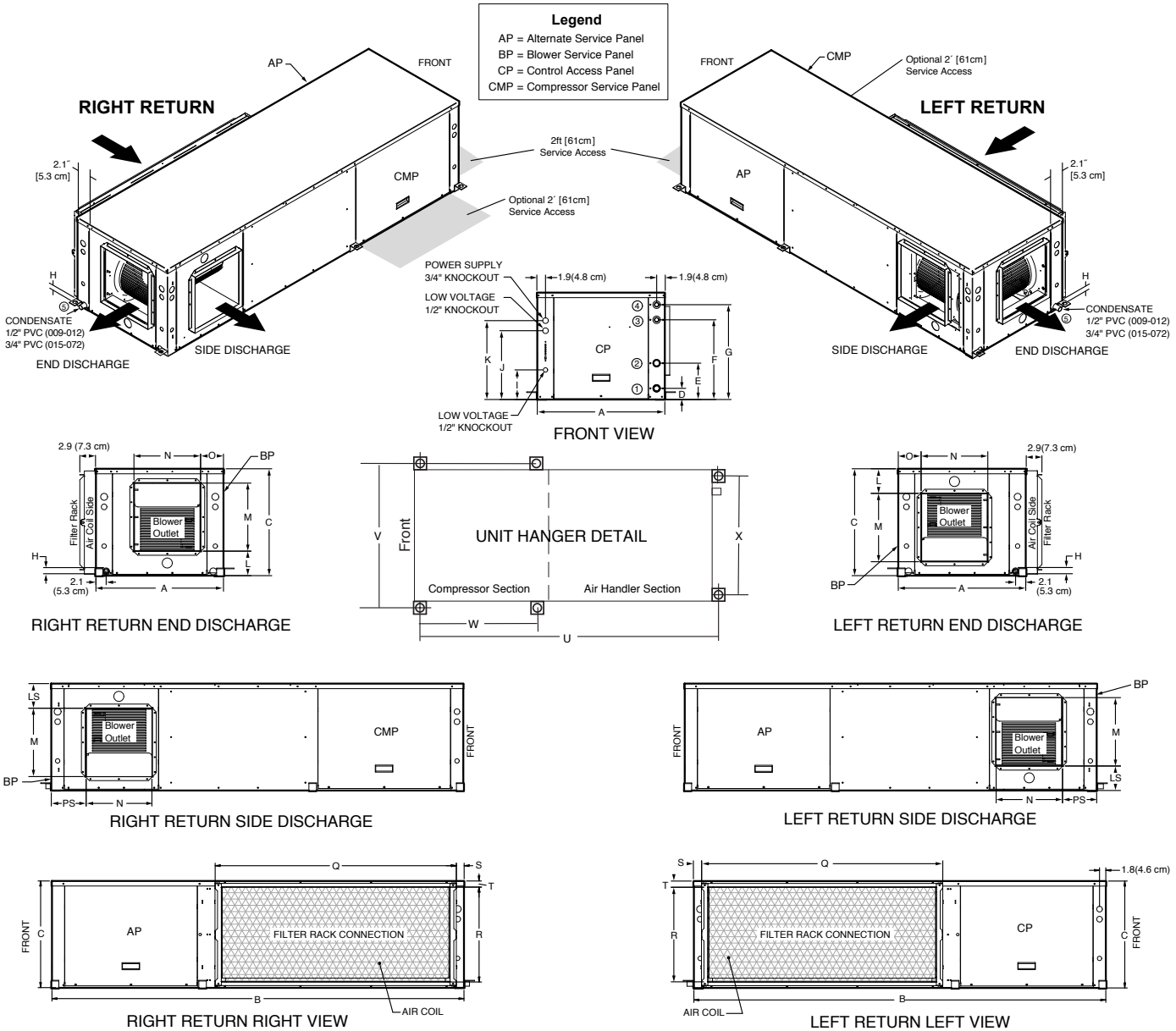

Horizontal Models	Overall Cabinet			Water Connections							Electrical Knockouts			Discharge Connection				Return Connection				Unit Hanger Dimensions				
	A	B	C	D	E	F	G	H	Loop	HWG FPT	I	J	K	L	M	N	O	P	Q	R	S	T	U	V	W	X
	Width	Depth	Height*	In	Out	HWG In	HWG Out	Condensate	Water FPT	HWG FPT	1/2" cond Low Voltage	1/2" cond Ext Pump	3/4" cond Power Supply	duct flange installed (±0.10 in)	Supply Height	Supply Depth			Return Depth	Return Height						
009-012	in.	22.5	44.0	17.3	2.3	5.3	11.9	14.9	0.8	1/2"	3.8	9.7	11.7	5.9	7.3	9.7	5.8	5.8	17.9	14.6	1.8	1.2	44.8	25.1	21.0	21.4
	cm.	57.2	111.8	43.9	5.8	13.5	30.2	37.8	2.1	12.7 mm	9.7	24.6	29.7	15.0	18.5	24.6	14.7	14.7	45.5	37.2	4.5	3.1	113.7	63.7	53.3	54.4
015-018	in.	22.5	53.0	19.3	2.3	5.3	13.8	16.8	0.8	3/4"	5.9	11.6	13.6	7.0	10.5	9.5	8.2	21.8	16.5	2.27	1.10	53.8	25.1	25.0	21.4	
	cm.	57.2	134.6	49.0	5.8	13.5	35.1	42.7	2.1	19.05 mm	14.9	29.5	34.5	17.8	26.7	24.1	20.8	20.8	55.4	41.9	5.8	2.8	136.5	63.7	63.5	54.4
022-030	in.	22.5	63.0	19.3	2.3	5.3	13.8	13.8	0.8	3/4"	5.9	13.7	15.7	6.5	10.5	9.4	6.5	5.8	30.5	16.9	2.8	1.7	63.4	24.8	25.3	21.1
	cm.	57.2	160.0	49.0	5.8	13.5	35.1	35.1	2.1	19.05 mm	14.9	34.7	39.8	16.6	26.5	23.8	16.5	14.6	77.3	42.9	7.1	4.4	161.0	63.0	64.3	53.6
036-038	in.	25.5	72.0	21.3	2.2	7.2	15.8	18.8	0.8	1"	5.9	13.7	15.7	4.9	13.6	13.2	4.6	6.8	35.5	18.9	2.8	1.7	72.4	27.8	29.3	24.1
	cm.	64.8	182.9	54.1	5.6	18.3	40.2	47.8	2.1	25.4 mm	14.9	34.7	39.8	12.4	34.6	33.5	11.6	17.2	90.0	47.9	7.1	4.4	183.9	70.6	74.4	61.2
042-049	in.	25.5	77.0	21.3	2.2	7.2	15.8	18.8	0.8	1"	5.9	13.7	15.7	4.9	13.6	13.2	4.6	6.8	40.5	18.9	2.8	1.7	77.4	27.8	29.3	24.1
	cm.	64.8	195.6	54.1	5.6	18.3	40.2	47.8	2.1	25.4 mm	14.9	34.7	39.8	12.4	34.6	33.5	11.6	17.2	102.7	47.9	7.1	4.4	196.6	70.6	74.4	61.2
060-072	in.	25.5	82.0	21.3	2.2	7.2	15.8	18.8	0.8	1"	5.9	13.7	15.7	4.9	13.6	13.2	4.6	6.8	45.5	18.9	2.8	1.7	82.4	27.8	29.3	24.1
	cm.	64.8	208.3	54.1	5.6	18.3	40.2	47.8	2.1	25.4 mm	14.9	34.7	39.8	12.4	34.6	33.5	11.6	17.2	115.4	47.9	7.1	4.4	209.3	70.6	74.4	61.2

Condensate 3/4" PVC stub extends from cabinet approximately 1.5" [38.1 mm]  
 Horizontal unit shipped with 1" (field adjustable to 2") duct collar/filter rack extending from unit 2.88" and is suitable for duct connection.  
 Discharge flange is field installed and extends 1" [25.4 mm] from cabinet

Residential cabinets are supplied with 1 in. swivel on loop water lines and 1/2 in. I.D. female sweat connections on HWG water lines.

# Physical Data (Single Speed)

Model	Single Speed											
	GS009	GS012	GS015	GS018	GS022	GS030	GS036	GS042	GS048	GS060	GS070	
Compressor (1 each)	LG Rotary				Copeland Scroll							
Factory Charge R410a, oz [kg] Vertical	29 [0.82]	42 [1.19]	38 [1.08]	40 [1.13]	58 [1.64]	62 [1.76]	82 [2.32]	82 [2.32]	98 [2.78]	110 [3.12]	146 [4.14]	
Factory Charge R410a, oz [kg] Horizontal	29 [0.82]	42 [1.19]	38 [1.08]	40 [1.13]	60 [1.70]	66 [1.87]	82 [2.32]	82 [2.32]	98 [2.78]	94 [2.67]	122 [3.46]	
<b>Fan Motor &amp; Blower</b>												
Fan Motor Type/Speeds	ECM	Not Available			ECM Variable Speed							
	PSC	PSC 4 Speeds			PSC 3 Speeds							
Fan Motor- hp [W]	ECM	Not Available			1/2 [373]	1/2 [373]	1/2 [373]	1/2 [373]	1/2 [373]	1/2 [373]	1 [746]	1 [746]
	PSC	1/10 [75]	1/10 [75]	1/6 [134]	1/6 [134]	1/5 [149]	1/3 [249]	1/2 [373]	1/2 [373]	1/2 [373]	1 [746]	1 [746]
Optional - Oversized PSC Fan Motor - hp [W]	PSC	Not Available			1/3 [249]	1/3 [249]	1/2 [373]	3/4 [560]	3/4 [560]	N/A	N/A	
Blower Wheel Size (Dia x W), in. [mm]	ECM	Not Available		9 x 7 [229 x 178]	9 x 7 [229 x 178]	9 x 7 [229 x 178]	9 x 7 [229 x 178]	11 x 10 [279 x 254]	11 x 10 [279 x 254]	11 x 10 [279 x 254]	11 x 10 [279 x 254]	11 x 10 [279 x 254]
	PSC	6 x 8 [152 x 203]	6 x 8 [152 x 203]	9 x 7 [229 x 178]	9 x 7 [229 x 178]	9 x 7 [229 x 178]	9 x 7 [229 x 178]	10 x 10 [254 x 254]	10 x 10 [254 x 254]	10 x 10 [254 x 254]	11 x 10 [279 x 254]	11 x 10 [279 x 254]
<b>Coax and Water Piping</b>												
Water Connections Size - FPT - in [mm]	1/2" [12.7]	1/2" [12.7]	3/4" [19.05]	3/4" [19.05]	3/4" [19.05]	3/4" [19.05]	1" [25.4]	1" [25.4]	1" [25.4]	1" [25.4]	1" [25.4]	
HWG Connection Size - FPT - in [mm]	Not Available			1/2" [12.7]	1/2" [12.7]	1/2" [12.7]	1/2" [12.7]	1/2" [12.7]	1/2" [12.7]	1/2" [12.7]	1/2" [12.7]	
Coax & Piping Water Volume - gal [l]	0.18 [0.7]	0.35 [1.3]	0.40 [1.5]	0.40 [1.5]	0.7 [2.6]	1.0 [3.8]	1.3 [4.9]	1.3 [4.9]	1.6 [6.1]	1.6 [6.1]	2.3 [8.7]	
<b>Vertical</b>												
Air Coil Dimensions (H x W), in. [mm]	12 x 16 [305 x 406]	16 x 16 [406 x 406]	19 x 20 [483 x 508]	19 x 20 [483 x 508]	28 x 20 [711 x 542]	28 x 20 [711 x 542]	28 x 25 [711 x 635]	32 x 25 [813 x 635]	32 x 25 [813 x 635]	36 x 25 [914 x 635]	36 x 25 [914 x 635]	
Air Coil Total Face Area, ft2 [m2]	1.3 [0.121]	1.8 [0.167]	2.6 [0.242]	2.6 [0.242]	3.9 [0.362]	3.9 [0.362]	4.9 [0.451]	5.6 [0.570]	5.6 [0.570]	6.3 [0.641]	6.3 [0.641]	
Air Coil Tube Size, in [mm]	5/16 [7.9]	3/8 [9.5]	5/16 [7.9]	5/16 [7.9]	3/8 [9.5]	3/8 [9.5]	3/8 [9.5]	3/8 [9.5]	3/8 [9.5]	3/8 [9.5]	3/8 [9.5]	
Air Coil Number of rows	3	3	3	3	3	3	3	3	3	4	4	
Filter Standard - 1" [24mm] Pleated MERV8 Throwaway, in [mm]	1 - 16 x 20 [406 x 508]	1 - 16 x 20 [406 x 508]	1 - 20 x 22 [508 x 559]	1 - 20 x 22 [508 x 559]	28 x 24 [712 x 610]	28 x 24 [712 x 610]	30 x 36 [762 x 914]	30 x 36 [762 x 914]	30 x 36 [762 x 914]	30 x 36 [762 x 914]	30 x 36 [762 x 914]	
Weight - Operating, lb [kg]	145 [66]	175 [79]	200 [91]	210 [95]	303 [137]	318 [144]	363 [165]	378 [171]	418 [189]	453 [205]	478 [217]	
Weight - Packaged, lb [kg]	152 [69]	185 [84]	210 [95]	220 [100]	313 [142]	328 [149]	373 [169]	388 [176]	428 [194]	463 [210]	488 [221]	
<b>Horizontal</b>												
Air Coil Dimensions (H x W), in. [mm]	12 x 16 [305 x 406]	16 x 16 [406 x 406]	18 x 21 [457 x 533]	18 x 21 [457 x 533]	18 x 30 [457 x 762]	18 x 30 [457 x 762]	20 x 35 [508 x 889]	20 x 40 [508 x 1016]	20 x 40 [508 x 1016]	20 x 45 [508 x 1143]	20 x 45 [508 x 1143]	
Air Coil Total Face Area, ft2 [m2]	1.3 [0.121]	1.8 [0.167]	2.6 [0.242]	2.6 [0.242]	3.9 [0.362]	3.9 [0.362]	4.9 [0.451]	5.6 [0.570]	5.6 [0.570]	6.3 [0.641]	6.3 [0.641]	
Air Coil Tube Size, in [mm]	5/16 [7.9]	3/8 [9.5]	5/16 [7.9]	5/16 [7.9]	3/8 [9.5]	3/8 [9.5]	3/8 [9.5]	3/8 [9.5]	3/8 [9.5]	3/8 [9.5]	3/8 [9.5]	
Air Coil Number of rows	3	3	3	3	3	3	3	3	3	3	3	
Filter Standard - 1" [25mm] Pleated MERV8 Throwaway, in [mm]	1 - 16 x 20 [406 x 508]	1 - 16 x 20 [406 x 508]	1 - 18 x 24 [457 x 610]	1 - 18 x 24 [457 x 610]	1 - 18 x 32 [457 x 813]	1 - 18 x 32 [457 x 813]	1 - 20 x 37 [686 x 940]	1 - 20 x 20 [508 x 508] 1 - 20 x 22 [508 x 559]	1 - 20 x 20 [508 x 508] 1 - 20 x 22 [508 x 559]	1 - 20 x 25 [508 x 635] 1 - 20 x 22 [508 x 559]	1 - 20 x 25 [508 x 635] 1 - 20 x 22 [508 x 559]	
Weight - Operating, lb [kg]	145 [66]	175 [79]	200 [91]	210 [95]	305 [138]	320 [145]	368 [167]	383 [174]	423 [192]	458 [208]	483 [219]	
Weight - Packaged, lb [kg]	152 [69]	185 [84]	210 [95]	220 [100]	320 [145]	335 [152]	383 [174]	398 [180]	438 [199]	473 [214]	498 [226]	



# Physical Data (Dual Capacity)

Model	Dual Capacity				
	GT026	GT038	GT049	GT064	GT072
Compressor (1 each)	Copeland 2-speed Scroll, UltraTech				
Factory Charge R410a, oz [kg]    Vertical	62 [1.76]	78 [2.21]	89 [2.52]	122 [3.46]	140 [3.97]
Factory Charge R410a, oz [kg]    Horizontal	60 [1.70]	76 [2.16]	89 [2.52]	124 [3.52]	160 [4.54]
<b>ECM Fan Motor &amp; Blower</b>					
Fan Motor Type/Speeds	ECM Variable Speed				
Fan Motor- hp [W]	1/2 [373]	1/2 [373]	1/2 [373]	1 [746]	1 [746]
Blower Wheel Size (Dia x W), in. [mm]	9 x 7 [229 x 178]	11 x 10 [279 x 254]	11 x 10 [279 x 254]	11 x 10 [279 x 254]	11 x 10 [279 x 254]
<b>Coax and Water Piping</b>					
Water Connections Size - FPT - in [mm]	3/4" [19.05]	1" [25.4]	1" [25.4]	1" [25.4]	1" [25.4]
HWG Connection Size - FPT - in [mm]	1/2" [12.7]	1/2" [12.7]	1/2" [12.7]	1/2" [12.7]	1/2" [12.7]
Coax & Piping Water Volume - gal [l]	0.7 [2.6]	1.3 [4.9]	1.6 [6.1]	1.6 [6.1]	2.3 [8.7]
<b>Vertical</b>					
Air Coil Dimensions (H x W), in. [mm]	28 x 20 [711 x 542]	28 x 25 [711 x 635]	32 x 25 [813 x 635]	36 x 25 [914 x 635]	36 x 25 [914 x 635]
Air Coil Total Face Area, ft2 [m2]	3.9 [0.362]	4.9 [0.451]	5.6 [0.570]	6.3 [0.641]	6.3 [0.641]
Air Coil Tube Size, in [mm]	3/8 [9.5]	3/8 [9.5]	3/8 [9.5]	3/8 [9.5]	3/8 [9.5]
Air Coil Number of rows	3	3	3	4	4
Filter Standard - 1" [25mm] Pleated MERV8 Throwaway, in [mm]	28 x 24 [712 x 610]	30 x 36 [762 x 914]	30 x 36 [762 x 914]	30 x 36 [762 x 914]	30 x 36 [762 x 914]
Weight - Operating, lb [kg]	303 [137]	368 [167]	418 [189]	463 [210]	478 [217]
Weight - Packaged, lb [kg]	313 [142]	378 [171]	428 [194]	473 [214]	488 [221]
<b>Horizontal</b>					
Air Coil Dimensions (H x W), in. [mm]	18 x 30 [457 x 762]	20 x 35 [508 x 889]	20 x 40 [508 x 1016]	20 x 45 [508 x 1143]	20 x 45 [508 x 1143]
Air Coil Total Face Area, ft2 [m2]	3.9 [0.362]	4.9 [0.451]	5.6 [0.570]	6.3 [0.641]	6.3 [0.641]
Air Coil Tube Size, in [mm]	3/8 [9.5]	3/8 [9.5]	3/8 [9.5]	3/8 [9.5]	3/8 [9.5]
Air Coil Number of rows	3	3	3	4	4
Filter Standard - 1" [25mm] Pleated MERV8 Throwaway, in [mm]	1 - 18 x 32 [457 x 813]	1 - 20 x 37 [686 x 940]	1 - 20 x 20 [508 x 508] 1 - 20 x 22 [508 x 559]	1 - 20 x 25 [508 x 635] 1 - 20 x 22 [508 x 559]	1 - 20 x 25 [508 x 635] 1 - 20 x 22 [508 x 559]
Weight - Operating, lb [kg]	305 [138]	373 [169]	423 [192]	468 [212]	483 [219]
Weight - Packaged, lb [kg]	320 [145]	388 [176]	438 [199]	483 [219]	498 [226]

6/15/2007

# Wiring Schematics - Residential

## GS Series - Single Speed Wiring Schematic - 208-230/60/1 - PSC

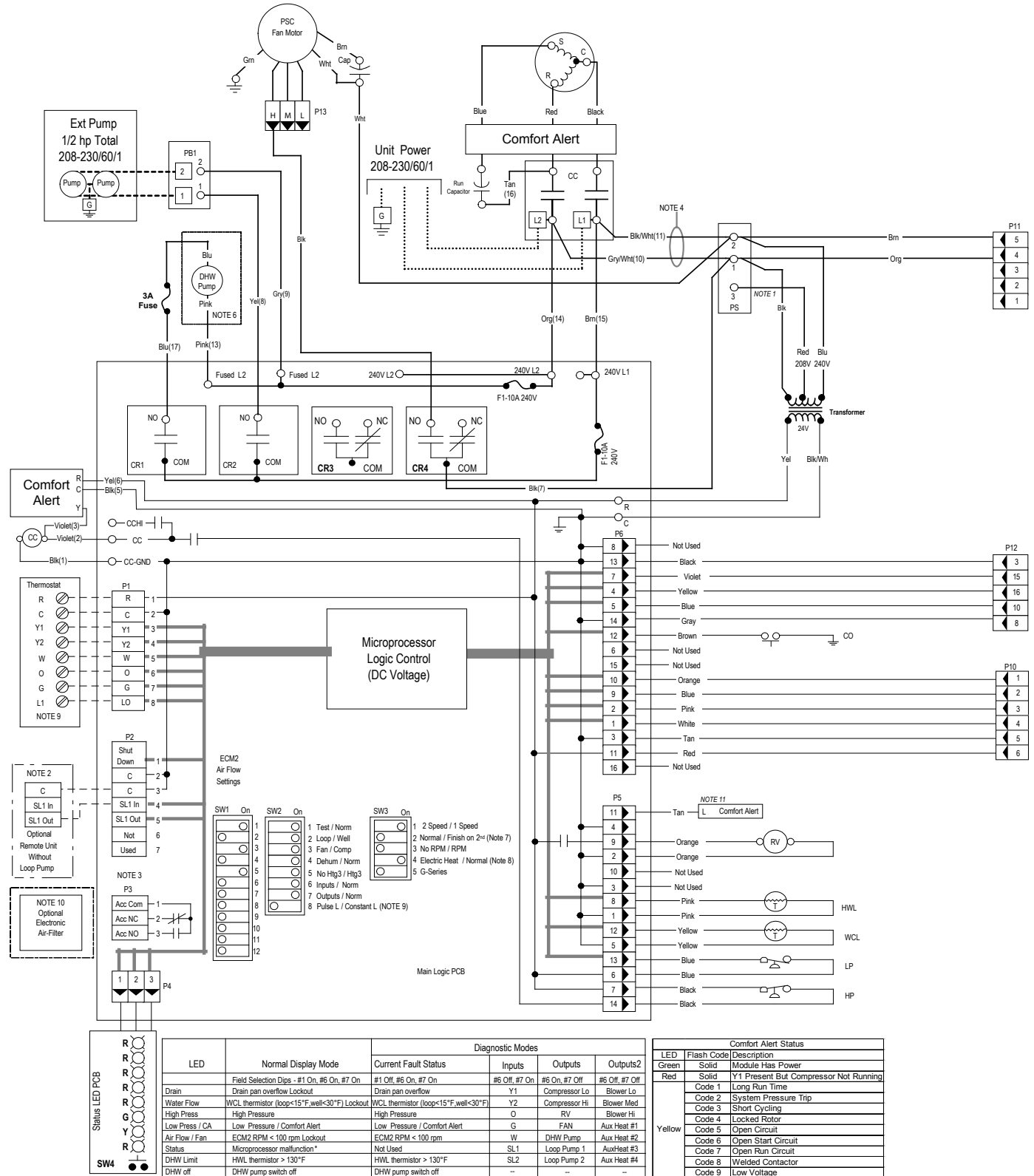

# Wiring Schematics - Residential cont.

## GS Series - Single Speed Wiring Schematic - 208-230/60/1 - PSC cont.

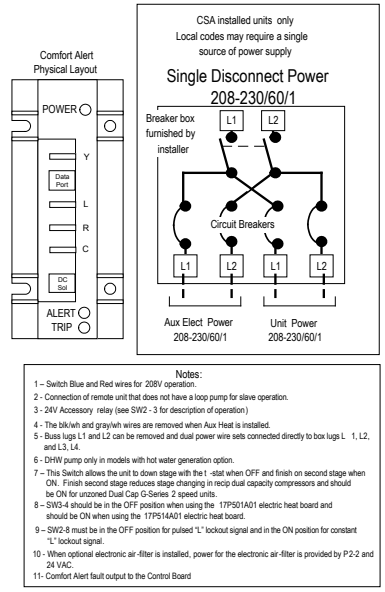
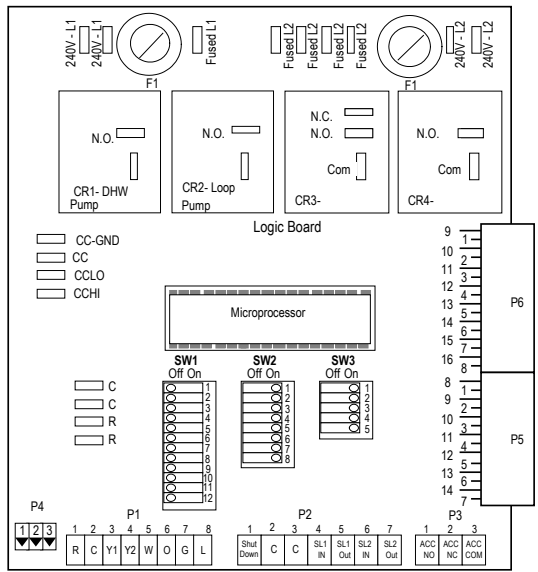
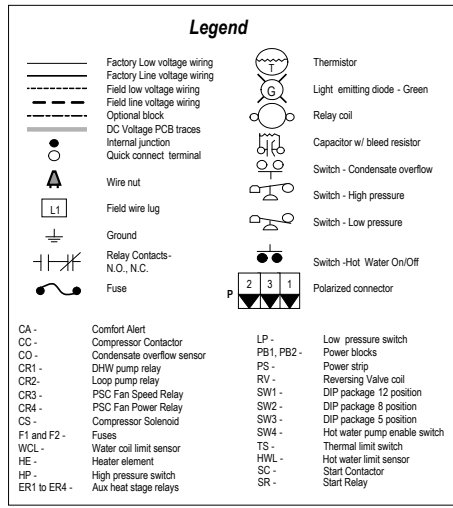
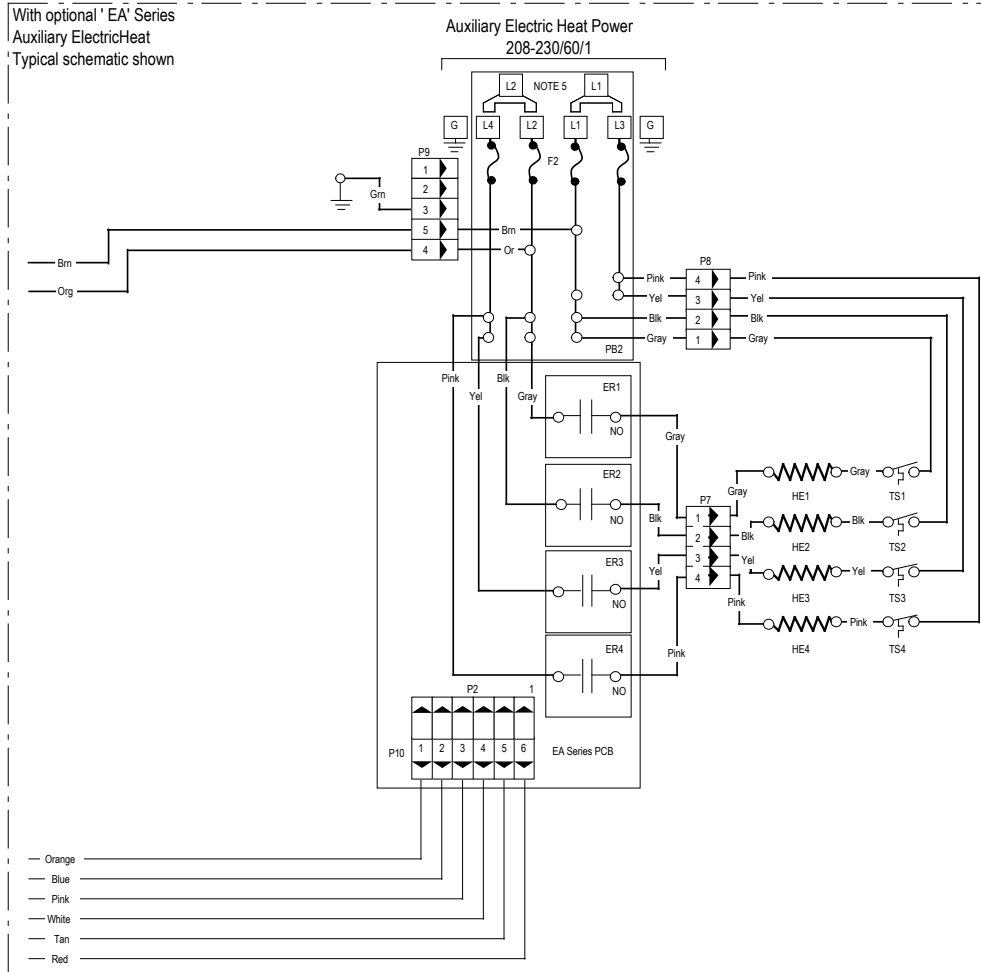

# Wiring Schematics - Residential cont.

## Single Speed - 208-230/60/1

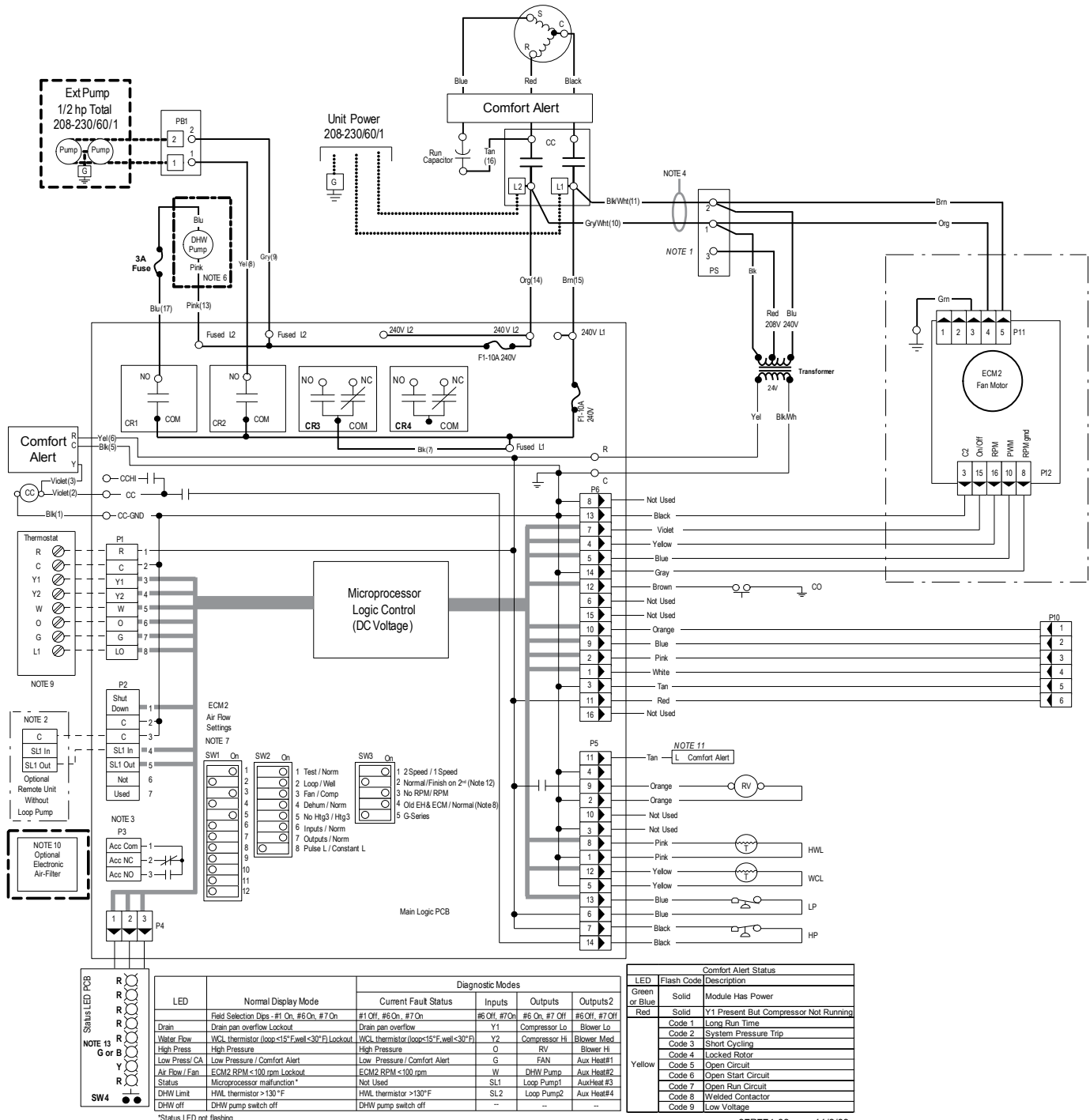

# Wiring Schematics - Residential cont.

## Single Speed - 208-230/60/1 cont.

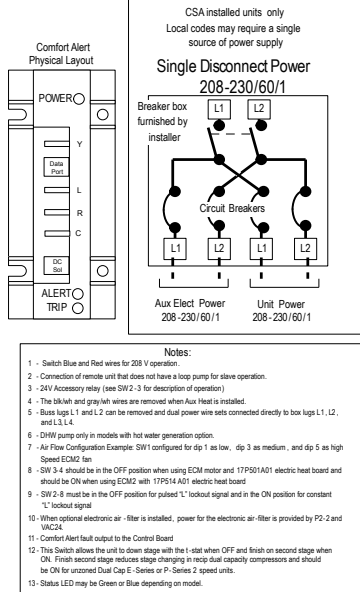
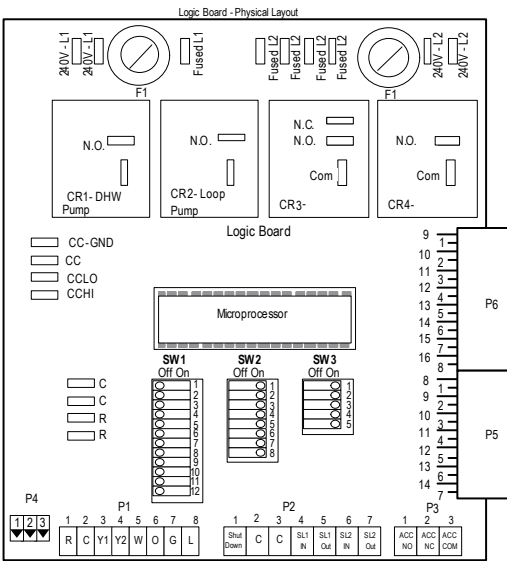
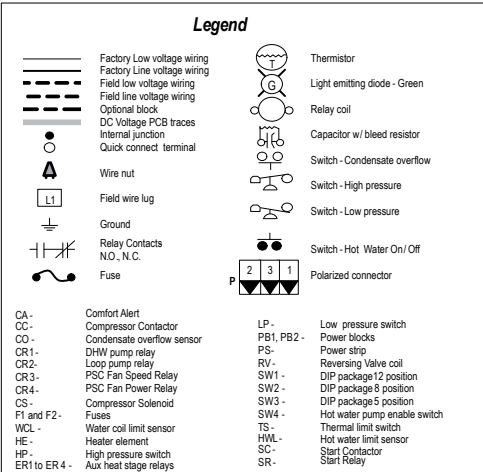
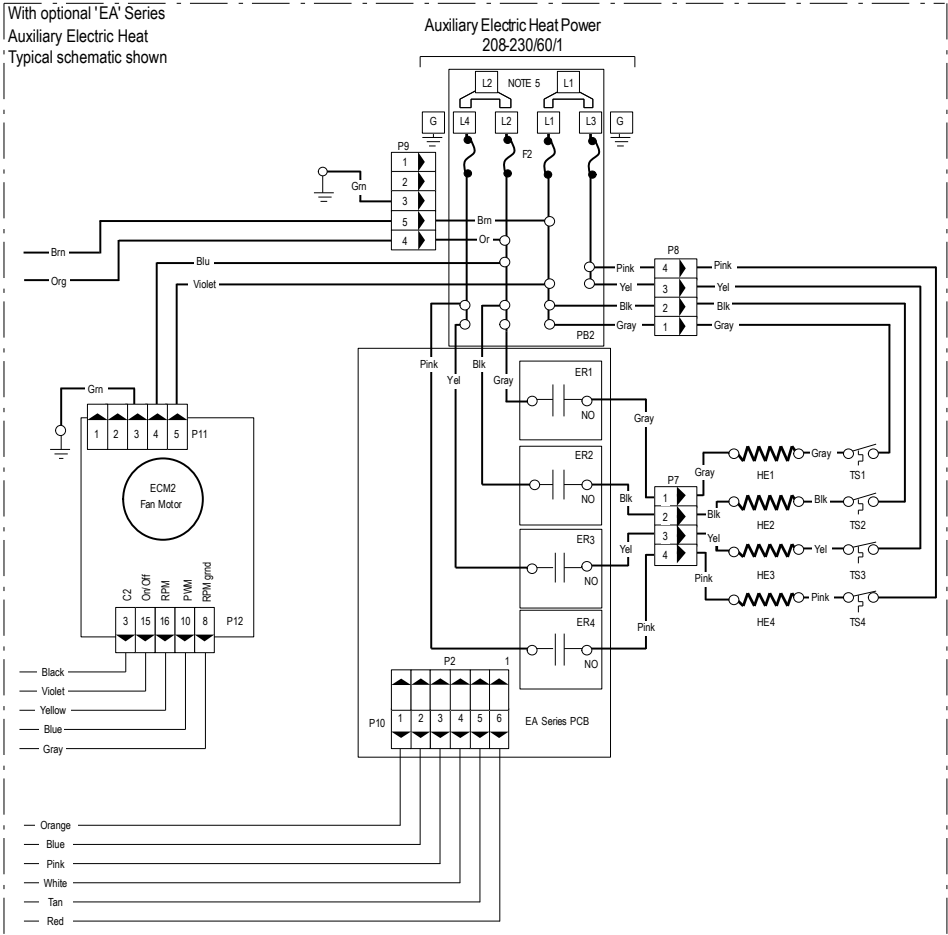

# Wiring Schematics - Residential cont.

## Dual Capacity - 208-230/60/1

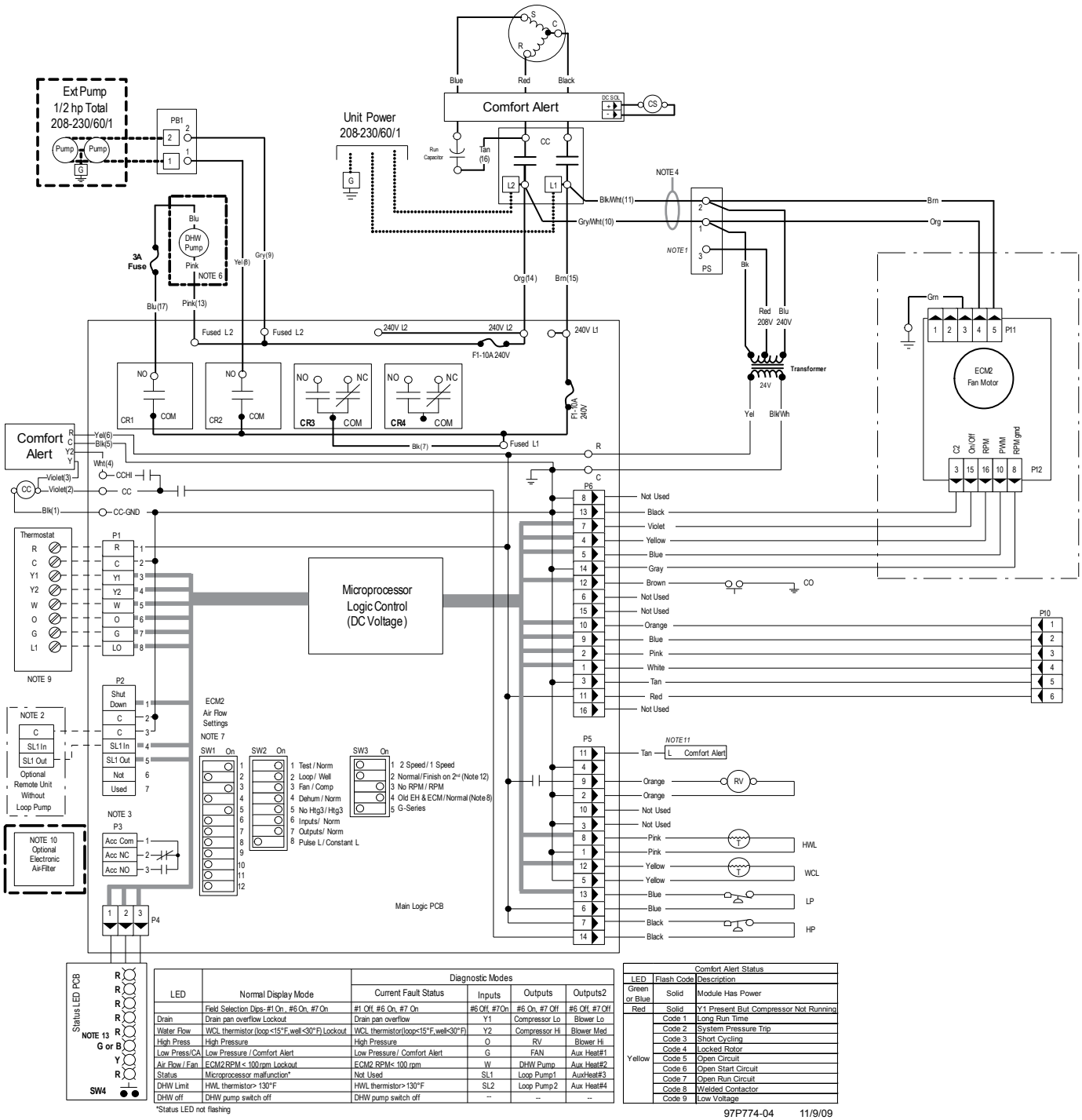

LED	Normal Display Mode	Diagnostic Modes			
		Current Fault Status	Inputs	Outputs	Outputs2
Drain	Field Selection Dips-#1 On, #6 On, #7 On	#1 Off, #6 On, #7 On	#6 Off, #7 On	#6 On, #7 Off	#6 Off, #7 Off
Water Flow	WCL thermostat (loop<15°F, well<30°F) Lockout	WCL thermostat(loop<15°F, well<30°F)	Y1	Compressor Lo	Blower Lo
High Press	High Pressure / Lockout	High Pressure	Y2	Compressor Hi	Blower Med
Low Press/CA	Low Pressure / Comfort Alert	Low Pressure	O	RV	Blower Hi
Air Flow / Fan	ECM2 RPM < 100 rpm Lockout	ECM2 RPM < 100 rpm	W	DHW Pump	Aux Heat#1
Status	Microprocessor malfunction*	Not Used	SL1	Loop Pump1	Aux Heat#3
DHW Limit	HWL thermostat<130°F	HWL thermostat<130°F	SL2	Loop Pump2	Aux Heat#4
DHW off	DHW pump switch off	DHW pump switch off	--	--	--

  

Comfort Alert Status		
LED	Flash Code	Description
Green or Blue	Solid	Module Has Power
Red	Solid	Y1 Present But Compressor Not Running
Yellow	Code 1	Long Run Time
	Code 2	System Pressure Trip
	Code 3	Locked Rotor
	Code 4	Locked Rotor
	Code 5	Open Circuit
	Code 6	Open Start Circuit
	Code 7	Open Run Circuit
	Code 8	Welded Contactor
	Code 9	Low Voltage

97P774-04 11/9/09

# Wiring Schematics - Residential cont.

## Dual Capacity - 208-230/60/1 cont.

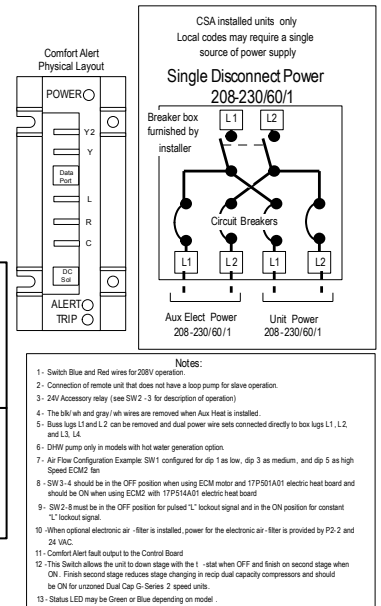
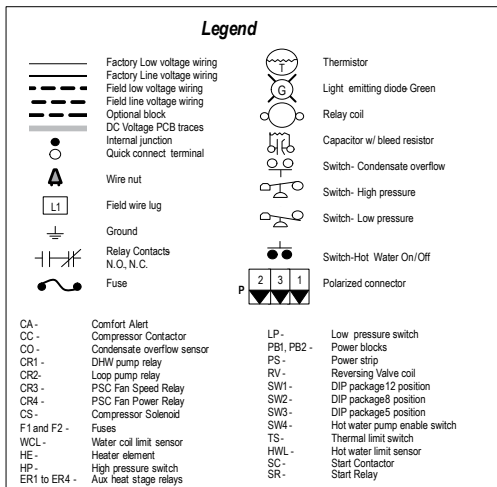
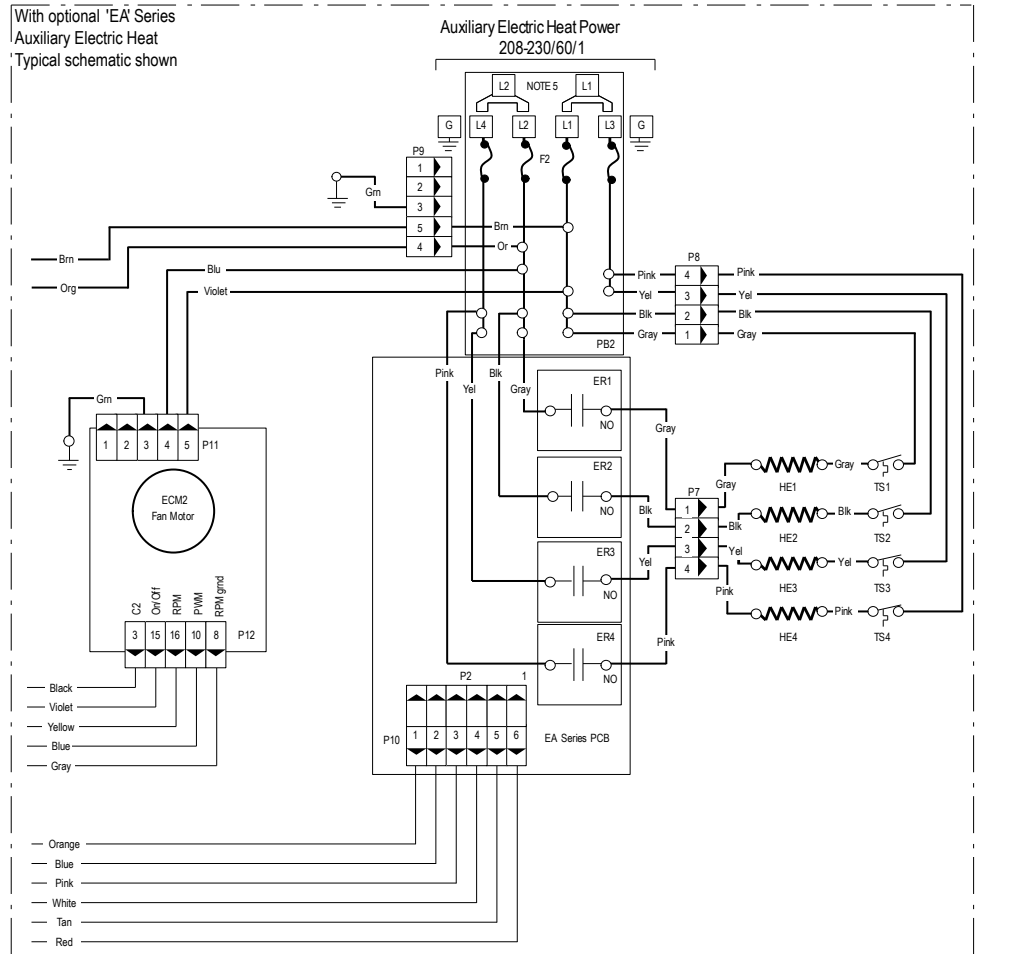

# Wiring Schematics - Commercial

## Single Speed - 208-230/60/1

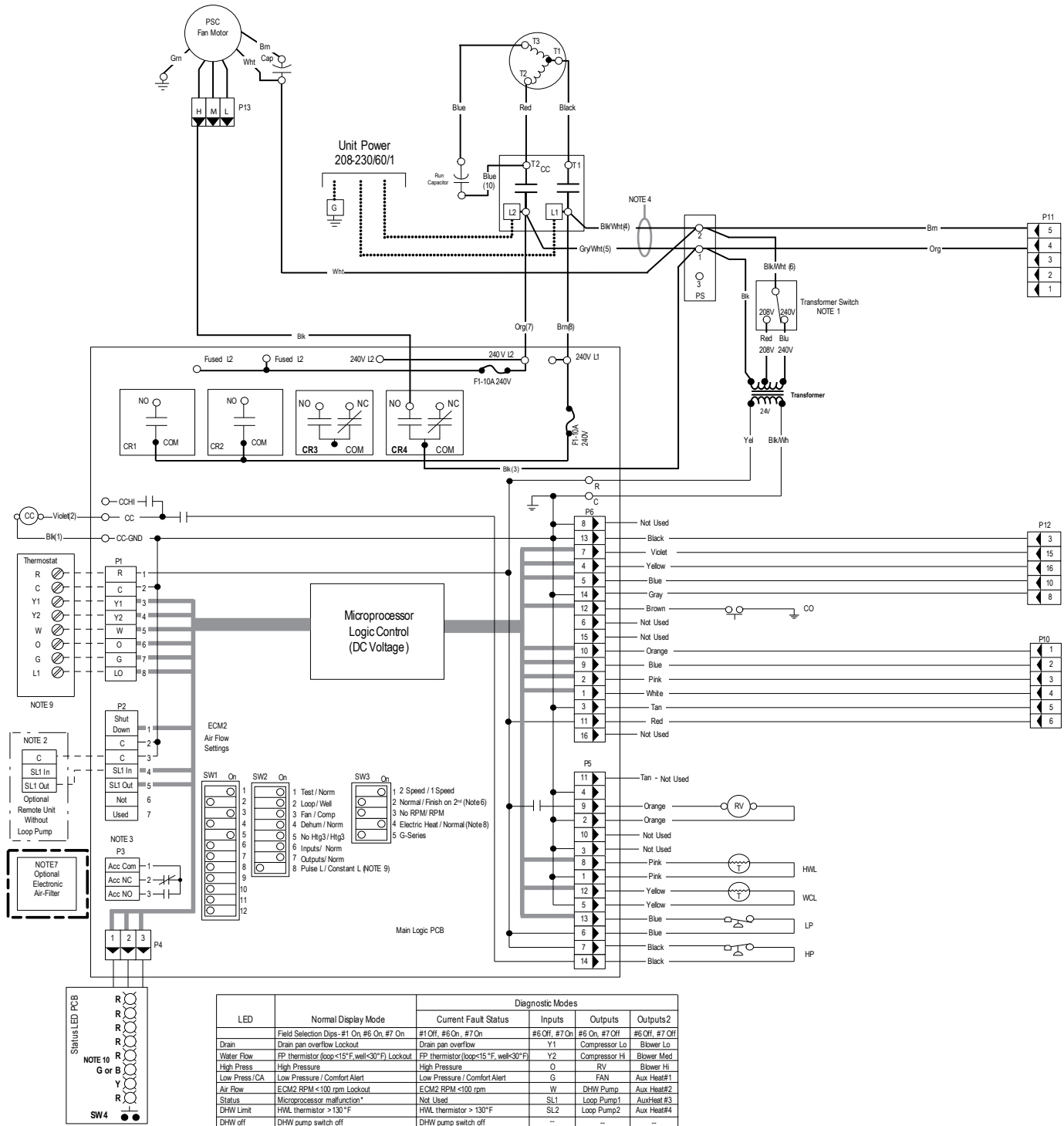



# Wiring Schematics - Commercial cont.

## Single Speed - 208-230/60/1 cont.

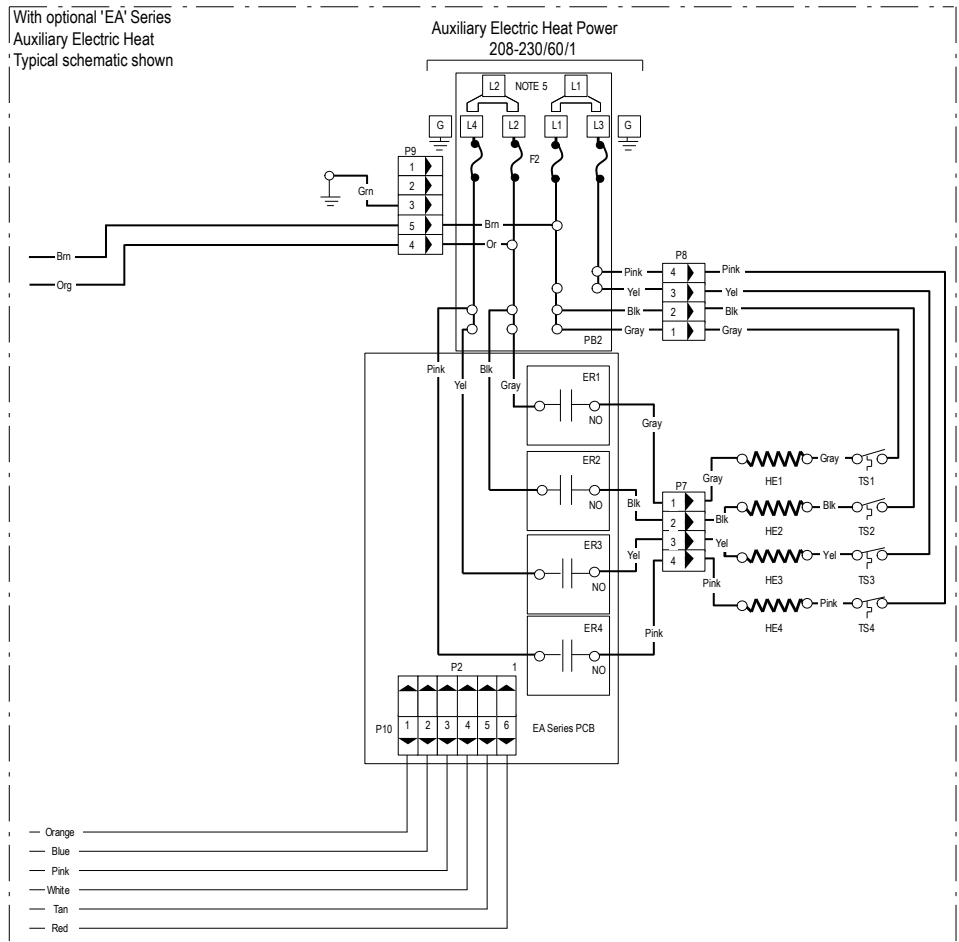

### Legend

	Factory Low voltage wiring		Thermistor
	Factory Line voltage wiring		Light emitting diode - Green
	Field low voltage wiring		Relay coil
	Field line voltage wiring		Capacitor w/ bleed resistor
	Optional block		Switch- Condensate overflow
	DC Voltage PCB traces		Switch- High pressure
	Internal junction		Switch- Low pressure
	Quick connect terminal		Switch-Hot Water Off/Off
	Wire nut		Polarized connector
	Field wire lug		
	Ground		
	Relay Contacts N.O., N.C.		
	Fuse		

CA -	Comfort Alert	PB1, PB2 -	Power blocks
CC -	Compressor Contactor	PS -	Power strip
CO -	Condensate overflow sensor	RV -	Reversing Valve coil
CR1 -	DHW pump relay	SW1 -	DIP package 12 position
CR2 -	Loop pump relay	SW2 -	DIP package 8 position
CR3 -	PSC Fan Speed Relay	SW3 -	DIP package 5 position
CR4 -	PSC Fan Power Relay	SW4 -	Hot water pump enable switch
CS -	Compressor Solenoid	TS -	Thermal limit switch
F1 and F2 -	Fuses	HWL -	Hot water limit sensor
HE -	Heater element	SC -	Start Contactor
HP -	High pressure switch	SR -	Start Relay
ER1 to ER4 -	Aux heat stage relays	WCL -	Water Coil Limit Sensor
LP -	Low pressure switch		

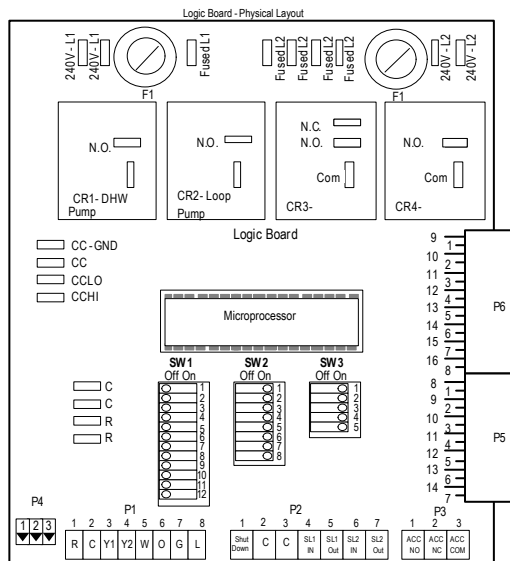

CSA installed units only  
Local codes may require a single source of power supply

### Single Disconnect Power 208-230/60/1

Notes:

- 1 - Place switch to 208V position to operate unit at 208V.
- 2 - Connection of remote unit that does not have a loop pump for slave operation.
- 3 - 24V Accessory relay (see SW2-3 for description of operation)
- 4 - The blk/wh and gray/wh wires are removed when Aux Heat is installed.
- 5 - Bus lugs L1 and L2 can be removed and dual power wire sets connected directly to bus lugs L1, L2, and L3,L4.
- 6 - This Switch allows the unit to down stage with the 1- stat when OFF and finish on second stage when ON. Finish second stage reduces stage changing in recip dual capacity compressors and should be ON for uncooled Dual Cap GS Series staged units.
- 7 - When optional electronic air-filter is installed, power for the electronic air-filter is provided by P2-2 and 24 VAC.
- 8 - SW3 - should be in the OFF position when using the TTP501 A01 electric heat board and should be ON when using the TTP514 A01 electric heat board.
- 9 - SW 28 must be in the OFF position for pulsed "L" lockout signal and in the ON position for constant "L" lockout signal.
- 10 - Blank LED may be Green or Blue depending on model.

97P774-40 08/25/08

# Wiring Schematics - Commercial cont.

## Dual Capacity - 208-230/60/1

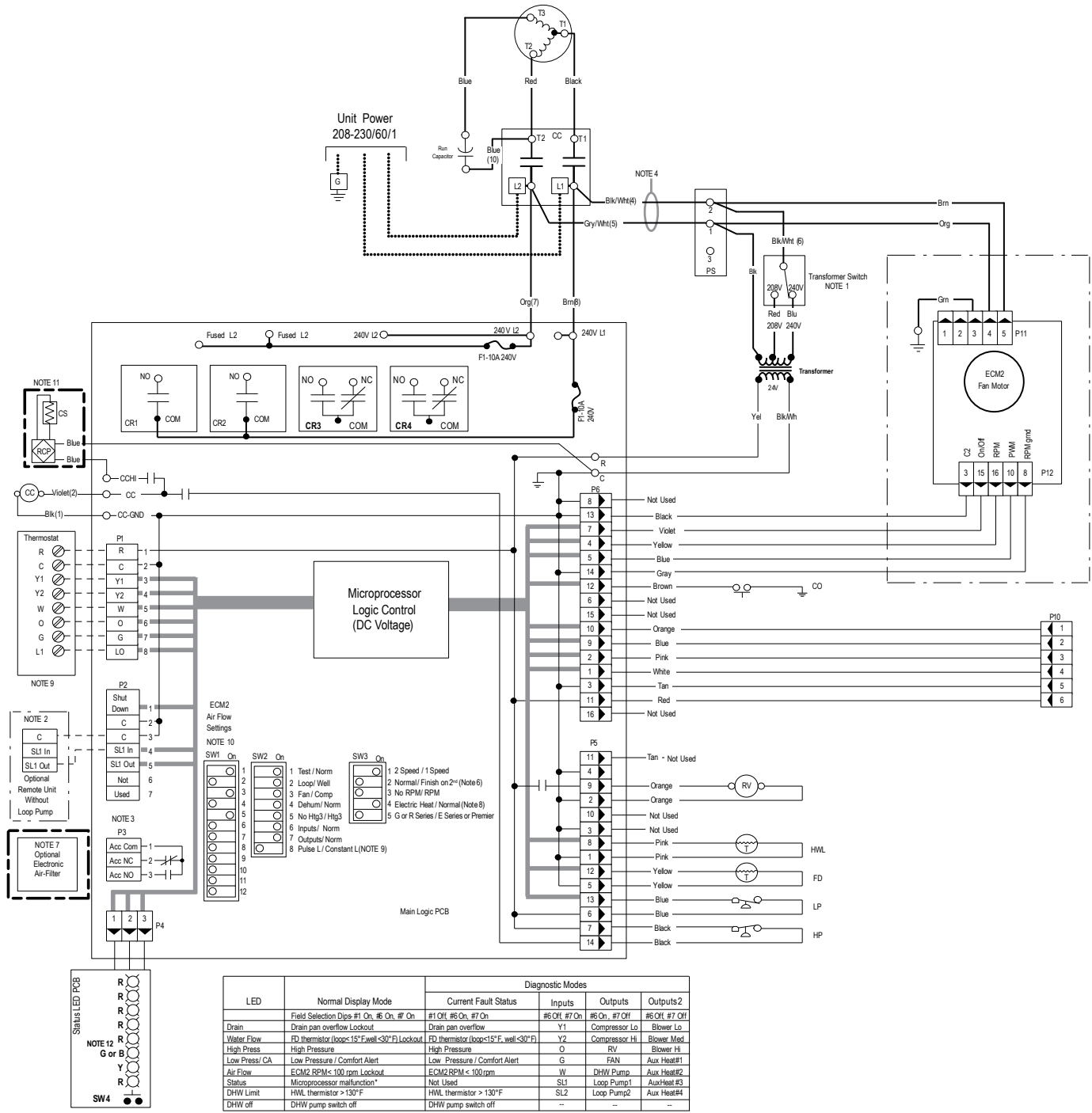

# Wiring Schematics - Commercial cont.

## Dual Capacity - 208-230/60/1 cont.

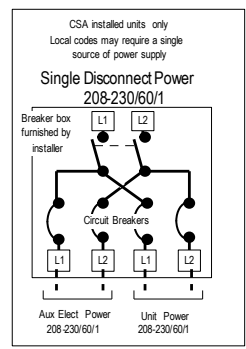
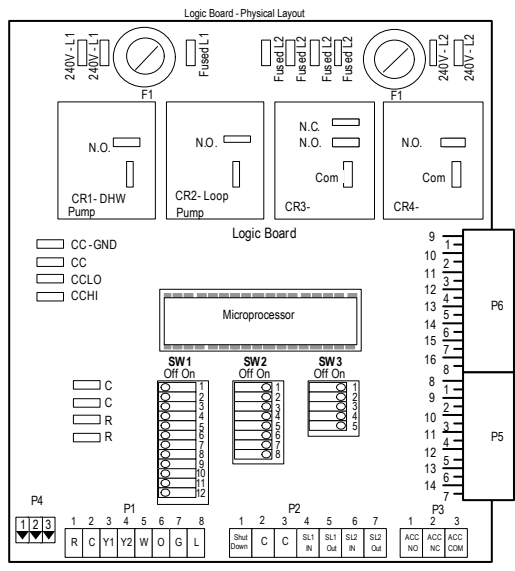
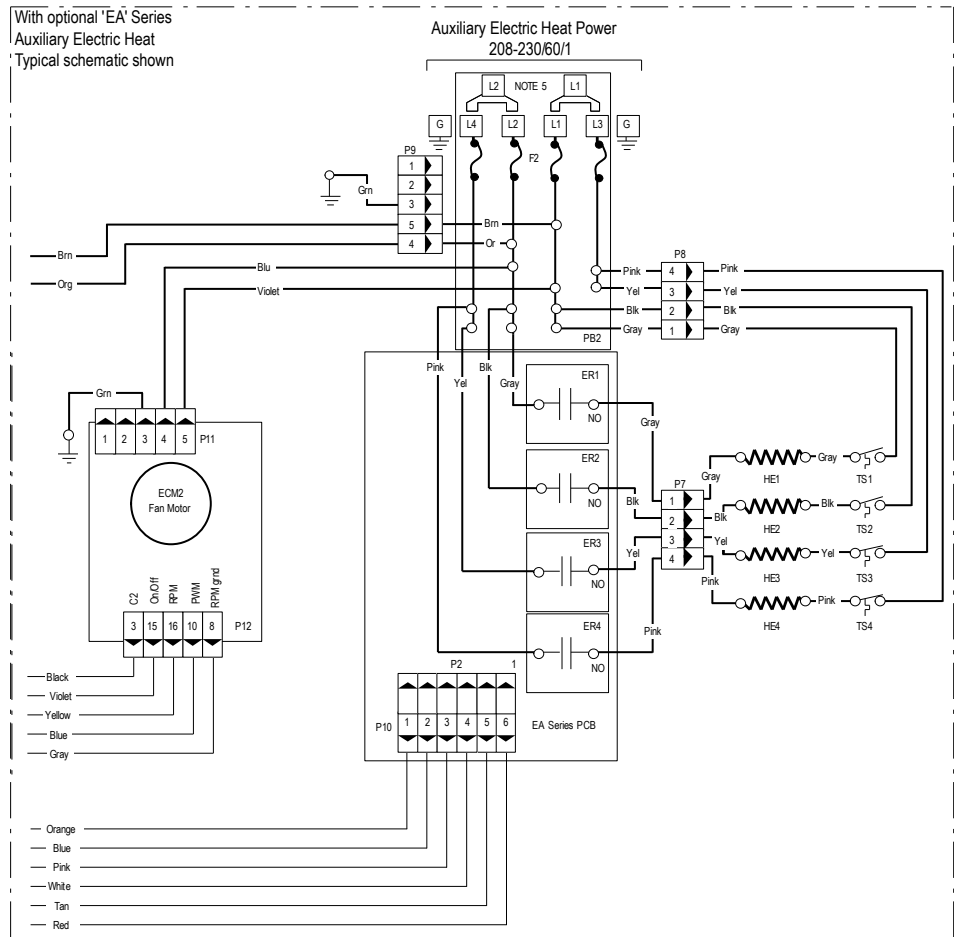

- Notes:**
- 1 - Place switch to 208V position to operate unit at 208V.
  - 2 - Connection of remote unit that does not have a loop pump for slave operation.
  - 3 - 24V Accessory relay (see SW2 -3 for description of operation)
  - 4 - The BK/wh and gray/wh wires are removed when Aux Heat is installed.
  - 5 - Blue legs L1 and L2 can be removed and dual power wire sets connected directly to bus legs L1, L2, and L3, L4.
  - 6 - This Switch allows the unit to down stage with the 1st when OFF and finish on second stage when ON. Finish second stage reduces stage changing in resp. dual capacity compressors and should be ON for uncondensed Dual Cap 2-speed units.
  - 7 - When optional electronic air filter is installed, power for the electronic air filter is provided by P2 24VAC.
  - 8 - SW3-4 should be in the OFF position when using the 17P501 A01 electric heat board and should be ON when using the 17P514 A01 electric heat board.
  - 9 - SW6-8 must be in the OFF position for "pulsed" L1 lockout signal and in the ON position for constant "L1" lockout signal.
  - 10 - Air Flow Configuration Example: SW1 configured for dip 1 as low, dip 3 as medium, and dip 5 Speed ECM fan.
  - 11 - Dual Capacity units only.
  - 12 - Status LED may be Green or Blue depending on model.

# Wiring Schematics - Commercial cont.

## Dual Capacity ECM2.3 - 460/60/3

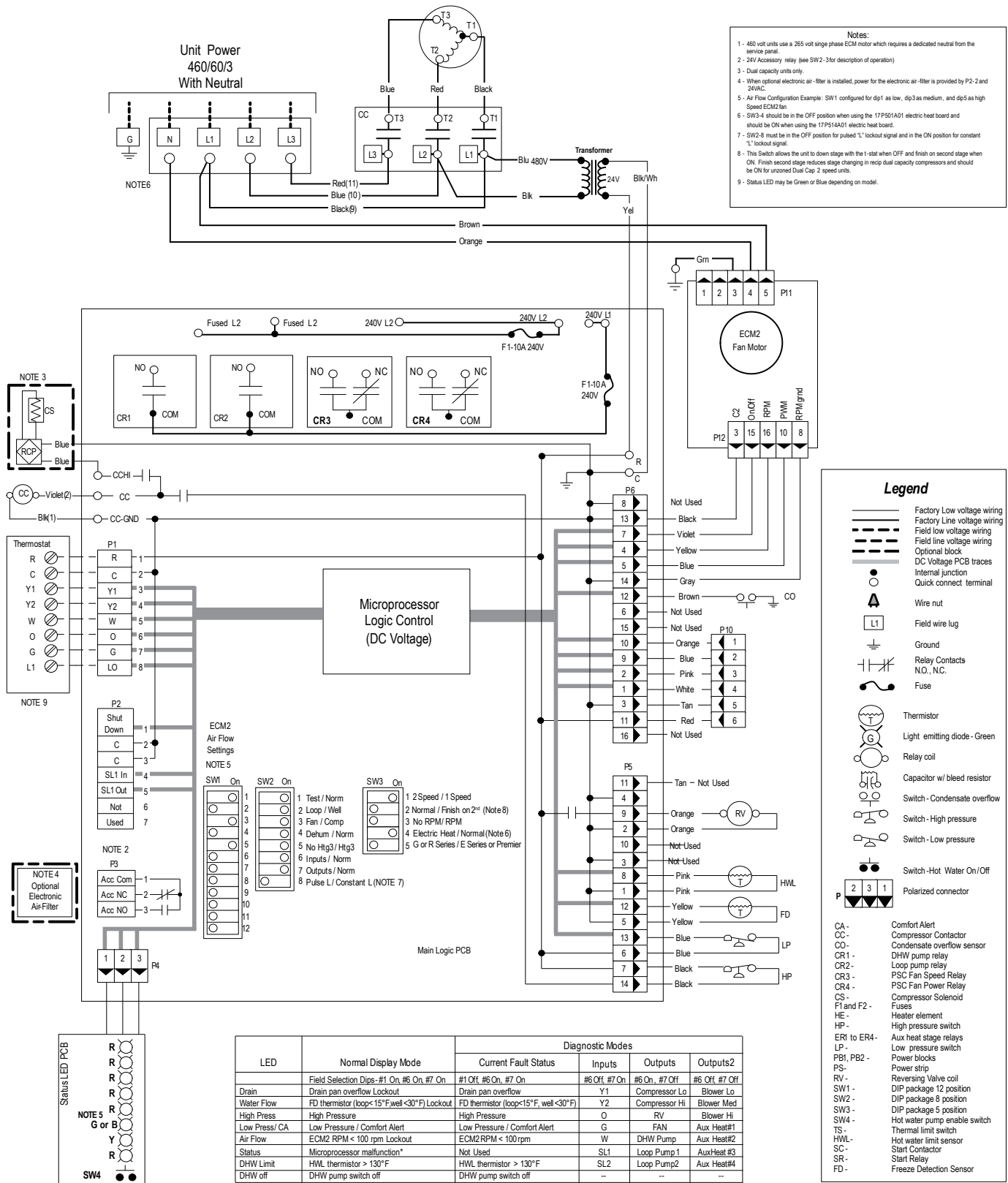

# Wiring Schematics - Commercial cont.

## Single Speed PSC - 460-575/60/3

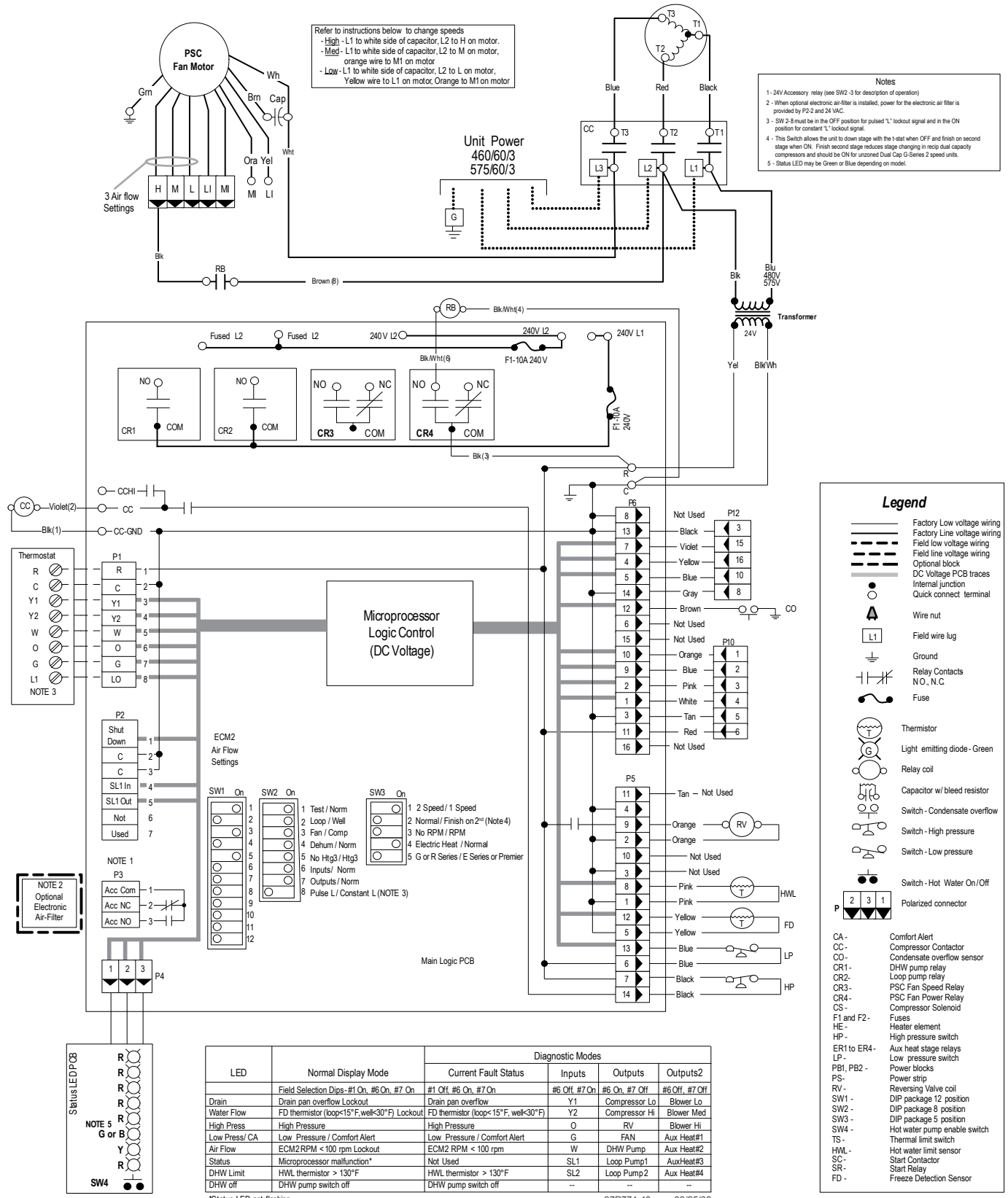

# Microprocessor Control

## Startup

The unit will not operate until all the inputs and safety controls are checked for normal conditions. At first power-up, a four minute delay is employed before the compressor is energized.

## Component Sequencing Delays

Components are sequenced and delayed for optimum space conditioning performance.

## Accessory Relay

An accessory relay on the control board allows for field connection of solenoid valves, electronic air cleaners, etc. The accessory relay has a normally open output and a normally closed output.

## Short Cycle Protection

The control employs a minimum "off" time of four minutes to provide for short cycle protection of the compressor.

## Condensate Overflow Protection

The GS/GT Series control board incorporates an impedance sensing liquid sensor at the top of the drain pan. Upon a continuous 30-second sensing of the condensate, compressor operation is suspended (see Fault Retry), and the condensate overflow lockout LED begins flashing.

## Shutdown Mode

A 24VAC common signal to the "shutdown" input on the control board puts the unit into shutdown mode. Compressor, hot water pump and fan operation are suspended.

## Safety Controls

The GS/GT Series control receives separate signals for a high pressure switch for safety, a low pressure switch to prevent loss of charge damage, and a low suction temperature thermistor for freeze sensing. Upon a continuous 30-second measurement of the fault (immediate for high pressure), compressor operation is suspended, the appropriate lockout LED begins flashing. (Refer to the "Fault Retry" section below.)

## Testing

The GS/GT Series control allows service personnel to shorten most timing delays for faster diagnostics. (Refer to the Field Selection DIP switch SW2-1 in the Microprocessor Control section.)

## Fault Retry

All faults (except for low RPM faults with the ECM2 fan motor) are retried twice before finally locking the unit out. An output signal is made available for a fault LED at the thermostat. The "fault retry" feature is designed to prevent nuisance service calls.

## Diagnostics

The GS/GT Series control board allows all inputs and outputs to be displayed on the LEDs for fast and simple control board diagnosis. (Refer to the Field Selection DIP Switch SW2-1 in the Microprocessor Control section.)

## Resistance Heat Control (208-230 Units)

The electric heat control module contains the appropriate high-voltage control relays. Control signals energize the relays in the proper sequence, and the LED display board indicates which stages are energized.

## Hot Water High Limit (Domestic Hot Water Option)

This mode occurs when the hot water input temperature is at or above 130°F for 30 continuous seconds. The DHW limit status LED on the unit illuminates and the hot water pump de-energizes. Hot water pump operations resume on the next compressor cycle or after 15 minutes of continuous compressor operation during the current thermostat demand cycle.

## Hot Water Justification

Since compressor hot gas temperature is dependant on loop temperature in cooling mode, loop temperatures may be too low to allow proper heating of water. The control will monitor water and refrigerant temperatures to determine if conditions are satisfactory for heating water. The DHW limit status LED on the unit illuminates when conditions are not favorable for heating water.

## Heating Operation

### Heat, 1st Stage (Y1)

The fan motor is started on low speed immediately (PSC ON), the loop pump is energized 5 seconds after the "Y1" input is received, and the compressor is energized on low capacity 10 seconds after the "Y1" input. The fan is switched to medium speed 15 seconds after "Y1" input (ECM only). The hot water pump is cycled 30 seconds after the "Y1" input.

### Heat, 2nd Stage (Y1,Y2) Single-Speed Units

The hot water pump is de-energized, which directs all heat to satisfying the thermostat, and the fan changes to high speed 15 seconds after the "Y2" input (ECM only).

### Heat, 2nd Stage (Y1,Y2) Dual Capacity Units

The second stage compressor will be activated 5 seconds after receiving a "Y2" input as long as the minimum first stage compressor run time of 1 minute has expired. The ECM blower changes from medium to high speed 15 seconds after the "Y2" input.

The Comfort Alert will delay the second stage compressor until 5 seconds after it receives a "Y2" from the board.

### Heat, 3rd Stage (Y1,Y2,W) Single-Speed Units

The first stage of resistance heat is energized 10 seconds after "W" input, and with continuous 3rd stage demand, the additional stages of resistance heat engage sequentially every 5 minutes.

# Microprocessor Control cont.

## Heat, 3rd Stage (Y1,Y2,W) Dual Capacity Units

The hot water pump is de-energized which directs all heat to satisfy the thermostat. The 1st stage of resistance heat is energized 10 seconds after "W" input, and with continuous 3rd stage demand, the additional stages of resistance heat engage sequentially every 5 minutes.

## Emergency Heat (W only)

The fan is started on high speed, and the first stage of resistance heat is energized 10 seconds after the "W" input. Continuing demand will engage the additional stages of resistance heat sequentially every 2 minutes.

## Cooling Operation

In all cooling operations, the reversing valve directly tracks the "O" input. Thus, anytime the "O" input is present, the reversing valve will be energized.

## Cool, 1st Stage (Y1,O)

The blower motor and hot water pump are started immediately, the loop pump(s) is energized 5 seconds after the "Y1" input is received. The compressor will be energized (on low capacity for Dual Capacity units) 10 seconds after the "Y1" input. The ECM blower will shift from low to medium speed 15 seconds after the "Y1" input (85% of medium speed if in dehumidification mode).

## Cool, 2nd Stage (Y1, Y2, O) Single Speed Units

The fan changes to high speed (85% of high speed if in dehumidification mode) 15 seconds after the "Y2" input (ECM only).

## Cool, 2nd Stage (Y1, Y2, O) Dual Capacity Units

The second stage compressor will be activated 5 seconds after receiving a "Y2" input as long as the minimum first stage compressor run time of 1 minute has expired. The ECM blower changes to high speed 15 seconds after the "Y2" input. (85% of high speed if in dehumidification mode). The Comfort Alert will delay the second stage compressor until 5 seconds after it receives a "Y2" from the board.

## Fan (G only)

The fan starts on low speed. Regardless of fan input "G" from thermostat, the fan will remain on low speed for 30 seconds at the end of each heating, cooling or emergency heat cycle.

A DIP switch on the GS/GT Series control allows field selection of 15% reduced fan speeds for cooling in the dehumidification mode or medium and high fan speeds for cooling in the normal mode.

Note: Fan speed can change automatically only with an ECM Motor.

## ECM2 Airflow Selection DIP Switches (SW1)

A 12-position DIP switch package on the GS/GT Series control allows the airflow levels to be set for low, medium and high speed. (Refer to the ECM Blower table in the Fan Performance Data - ECM section.)

Only three of the DIP switches can be in the "on" position. The first "on" switch (the lowest position number) determines the "low speed fan" setting. The second "on" switch determines the "medium speed fan" setting, and the third "on" switch determines the "high speed fan" setting, (see the Fan Performance Data - ECM section).

## Lockout Conditions

During lockout mode, the appropriate unit and thermostat lockout LEDs will illuminate. The compressor, loop pump, hot water pump, and accessory outputs are de-energized. Unless the lockout is caused by an ECM2 low RPM fault, the fan will continue to run on low speed. If the thermostat calls for heating, emergency heat operation will occur.

Comfort Alert lockouts cannot be reset at the thermostat. All other lockout modes can be reset at the thermostat after turning the unit off, then on, which restores normal operation but keeps the unit lockout LED illuminated. Interruption of power to the unit will reset a lockout without a waiting period and clear all lockout LEDs.

## High Pressure

This lockout mode occurs when the normally closed safety switch is opened momentarily (set at 600 PSI).

## Low Pressure

This lockout mode occurs when the normally closed low pressure switch is opened for 30 continuous seconds (set at 40 PSI). A low pressure fault may also be indicated when a Comfort Alert lockout has occurred.

## Freeze Sensing (Water Flow)

This lockout mode occurs when the freeze thermistor temperature is at or below the selected freeze sensing point (well 30°F or loop 15°F) for 30 continuous seconds.

## Condensate Overflow

This lockout mode occurs when the condensate overflow level has been reached for 30 continuous seconds.

## Fan RPM

The control board monitors fan RPM to sense operation. This lockout mode occurs if the fan RPM falls below the low RPM limit (100 RPM) for 30 continuous seconds.

# Microprocessor Control cont.

## Compressor Monitoring/Comfort Alert

The Comfort Alert displays abnormal compressor conditions through a unique flash code and communicates the conditions to the heat pump microprocessor control. The heat pump microprocessor will determine which fault to act on and ignore. Fault codes 2 (system pressure), 4 (locked rotor), 6 (open start circuit), and 7 (open run circuit) will result in a lockout. All other fault codes are passive. All compressor alerts are displayed on the module by flashing the yellow Alert LED a specific number of times consecutively followed by a pause, and then repeated. The number of consecutive flashes or "Flash Code" correlates to a specific abnormal condition. The red "TRIP" LED means there is a thermostat demand signal "Y" present but the compressor is not running. The green "POWER" LED means the module has power.

Green "POWER" LED - module has power

Red "TRIP" LED - Thermostat "Y" demand signal is present, but the compressor is not running.

Comfort Alert Flash Codes		
Yellow "ALERT" LED	LED Description	Cause
Flash Code 1	Long Run Time	Eighteen consecutive hours of compressor run time
Flash Code 2	System Pressure Trip	Not applicable
Flash Code 3	Short Cycling	Compressor run time of less than 3 minutes on 4 consecutive cycles
Flash Code 4	Locked Rotor	Four consecutive compressor protector trips indicating compressor won't start
Flash Code 5	Open Circuit	"Y" thermostat demand signal with no compressor current
Flash Code 6	Open Start Circuit	"Y" thermostat demand signal with no current in the start circuit
Flash Code 7	Open Run Circuit	"Y" thermostat demand signal with no current in the run circuit
Flash Code 8	Welded Contactor	Current detected with no "Y" thermostat demand signal present
Flash Code 9	Low Voltage	Less than 17 VAC detected in control circuit

\* Flash code number corresponds to a number of LED flashes, followed by a pause and then repeated.

\* TRIP and ALERT LEDs flashing at the same time indicates control circuit voltage is too low for operation.

\* Reset ALERT flash code by removing 24 VAC power from module.

\* Last ALERT flash code is displayed for 1 minute after module is powered on.

## Resetting Comfort Alert Codes

Alert codes can be reset manually by cycling power off and on to the Comfort Alert module. Alert codes will reset automatically if conditions return to normal.

Flash Code Number	LED Description	Automatic Reset of Alert Codes
Flash Code 1	Long Run Time	Thirty "alert free" on and off cycles to reset automatically
Flash Code 2	System Pressure Trip	Not applicable
Flash Code 3	Short Cycling	Four "alert free" on and off cycles to reset automatically
Flash Code 4	Locked Rotor	Four "alert free" on and off cycles to reset automatically
Flash Code 5	Open Circuit	One "alert free" on and off cycles to reset automatically
Flash Code 6	Open Start Circuit	One "alert free" on and off cycles to reset automatically
Flash Code 7	Open Run Circuit	One "alert free" on and off cycles to reset automatically
Flash Code 8	Welded Contactor	One "alert free" on and off cycles to reset automatically
Flash Code 9	Low Voltage	Resets when voltage rises above 19 VAC

\* Reset ALERT flash code by removing 24 VAC power from module.



# Microprocessor Control cont.

## Thermostat Displays

### Fault Flash

When using a TA32W02 or TP32W03 thermostat and SW2-8 is in the pulsing "L" position, FaultFlash will enable a user to view the thermostat and count the fault indicator flashes to determine the lockout condition the unit is experiencing.

### ComfortTalk

When using a TP32U03, 04 or 05 thermostat and SW2-8 is in the pulsing "L" position, ComfortTalk will enable the user to view the thermostat and determine the fault. The thermostat can be configured to show either lockout text or lockout codes.

The LED board on the front of the unit will display all lockouts. The Low Pressure LED will flash for a low pressure condition or a Comfort Alert fault. If the low pressure lockout was caused by Comfort Alert codes 4, 6 or 7, then the Comfort Alert will be flashing. If no Comfort Alert code is visible, then it is a low pressure lockout.

The following tables show the codes that will be displayed on the different ComfortTalk and FaultFlash thermostats.

#### FaultFlash Thermostats

TA32W02 and TP32W03 Thermostats	
Thermostat Display Lockout Code	Lockout Description
2 Flashes	High Pressure Fault
3 Flashes	Low Pressure Fault
4 Flashes	Not Applicable
5 Flashes	Water Flow Fault
6 Flashes	Not Applicable
7 Flashes	Condensate Fault
8 Flashes	Voltage out of Range
9 Flashes	RPM Fault
10 Flashes	Comfort Alert Compressor Module Fault

Lockout code 10 - see Comfort Alert module to determine the specific flash code for compressor abnormalities.

#### ComfortTalk Thermostats

TP32U03, TP32U04 and TP32U05 Thermostats	
Thermostat Display Lockout Code	Lockout Description
"High Pressure" or "E2"	High Pressure Fault
"Low Pressure" or "E3"	Low Pressure Fault
"E4"	Not Applicable
"Water Flow" or "E5"	Water Flow Fault
"E6"	Not Applicable
"Condensate" or "E7"	Condensate Fault
"Voltage Range" or "E8"	Voltage out of Range
"RPM" or "E9"	RPM Fault
"Comfort Alert" or "E10"	Comfort Alert Compressor Module Fault

These thermostats can be configured to display the lockout condition "text" or error number.  
\* A slow flash of 1 second on and off means the heat pump microprocessor SW2-1 is configured for "Test Mode" or thermostat is miswired.

Lockout code 10 - see Comfort Alert module to determine the specific flash code for compressor abnormalities.

# Microprocessor Control cont.

## DIP Switch Settings

Prior to powering unit, ensure that all DIP switches on SW2 & SW3 are set properly according to the tables below.

FACTORY SETUP DIP SWITCHES (SW3)				
DIP SWITCH NUMBER		DESCRIPTION	OFF POSITION	ON POSITION
SW 3-	1	<b>Dual Capacity/Single-Speed</b> Configures the control for single-speed compressor operation or dual capacity operation.	Dual Capacity Operation	Single-Speed Operation
SW 3-	2	<b>Zoned/Finish on Second Stage</b> This switch allows the unit to down stage with the thermostat when off and finish with second stage when on. Finish on second stage reduces stage changing in reciprocating dual capacity compressors.	Normal - All Other Systems	Finish on 2nd - Unzoned Dual Capacity E Series or Premier 2 Speed
SW 3-	3	<b>No RPM/RPM</b> Configures the control to monitor the RPM output of an ECM/ECM2 blower motor. When using IntelliZone or a PSC fan motor, the control should be configured for "NO RPM" sensing.	PSC Fan/RPM Monitoring Disabled	ECM-ECM2 Fan/RPM Monitoring Enabled
SW 3-	4	<b>Electric heat and ECM2</b> Allows backward compatibility with older P Series. In the Off position this switch allows older electric heat board (17P501A01) and older ECM (square end) compatibility. On is for all newer EH board (17P514A01) and ECM2 (round end).	Old EH & Old ECM	Normal
SW 3-	5	On dual capacity units this switch allows stage change: on the fly when off, and 1 minute delay when on. A delay is required on all reciprocating dual capacity units.	G Series	E Series or P Series

NEW

FIELD SELECTION DIP SWITCHES (SW2)				
DIP SWITCH NUMBER		DESCRIPTION	OFF POSITION	ON POSITION
SW 2-	1	<b>Service Test Mode</b> On the control, allows field selection of "NORMAL" or "TEST" operational modes. Test mode accelerates most timing functions 16 times to allow faster troubleshooting. Test mode also allows viewing the "CURRENT" status of the fault inputs on the LED display.	Test Mode	Normal Speed Operation
SW 2-	2	<b>Freeze Sensing Setting</b> Allows field selection of freeze thermistor fault sensing temperatures for well water (30°F) or antifreeze-protected (15°F) earth loops.	Loop Water Freeze Protection 15° F	Well Water Freeze Protection 30° F
SW 2-	3	<b>Accessory Relay</b> Allows field selection of the accessory relay to operate with the compressor or fan.	Acc Relay Tracks Fan	Acc Relay Tracks Compressor
SW 2-	4	<b>Fan Speed Control</b> Allows field selection of reduced fan speed (85% of selected medium and high speed – ECM only) for cooling in the dehumidification mode.	Dehumidification Fan Speeds	Normal Fan Speeds
SW 2-	5	<b>Auxiliary Off</b> Disables 3rd-stage Heating. Full emergency heat would still be available if needed.	Disable Heating Stage 3	Enable Heating Stage 3
SW 2-	6	<b>Diagnostics Inputs</b> Allows viewing the inputs from the thermostat to the control board such as Y1, Y2, O, G, W, SL1-In on the LED display.	Diagnostic Inputs Viewed at LEDs	Normal Display Viewed at LEDs
SW 2-	7	<b>Diagnostics Outputs</b> Allows viewing the outputs from the control board such as compressor, reversing valve, blower, hot water pump, and loop pump on the LED display.	Diagnostic Outputs Viewed at LEDs	Normal Display Viewed at LEDs
SW 2-	8	<b>Thermostat Selection</b> Configures the control for a pulsed lockout signal (ComforTalk and FaultFlash thermostats) or continuous 5 VAC lockout signal.	Pulsed "L" signal	Continuous "L" signal

NEW

## Optional FX10 Microprocessor Control

### (Only available on Commercial units)

The Johnson Controls FX10 board is specifically designed for commercial heat pumps and provides control of the entire unit as well as input ports for N2 Open, LonTalk, BacNet communication protocols as well as an input port for a user interface. The user interface is an accessory item that can be used to aid in diagnostics and unit setup. A 16 pin low voltage terminal board provides terminals for common field connections.

### FX10 Operation

- **Startup**  
The unit will not operate until all the inputs and safety controls are checked for normal operating conditions.
- **Fault Retry**  
All faults are tested twice before finally locking the unit out to prevent nuisance service calls.
- **Component Sequencing Delays**  
Components are sequenced and delayed for optimum unit performance. See table below.

CONTROL TIMING	
Lead compressor ON delay	30 seconds
Short cycle delay	4 minutes
Minimum compressor ON time	2 minutes (except for fault condition)
High pressure fault recognition	Less than 1 second
Low pressure fault recognition delay	30 seconds
Freeze protection fault recognition delay	30 seconds
Condensate overflow fault recognition delay	30 seconds
Low pressure fault bypass delay	2 minutes
Freeze protection fault bypass delay	2 minutes
Random start delay	0-120 seconds

- **Short Cycle Protection**  
The control allows a minimum compressor off time of 4 minutes and a minimum compressor run time of 2 minutes for short cycle protection.
- **Random Start**  
A random start delay of 1 to 120 seconds is generated after each power up to prevent simultaneous startup of all units within a building after the release from an unoccupied cycle or power loss.
- **Emergency Shutdown**  
A normally open dry contact must be placed between DI2 and PB2-L2. Closing the contact will set the unit into emergency shutdown mode. All unit operation is suspended while in emergency shutdown mode.
- **Condensate Overflow Protection**  
The board incorporates an impedance liquid sensor at the top of the condensate drain pan. Upon a continuous 30-second sensing of the condensate, the operation of the unit is suspended.
- **Safety Controls**  
The FX10 board receives separate signals from a high pressure switch for safety, a low pressure switch to detect loss of refrigerant charge and a low suction temperature thermistor for freeze sensing. Upon a continuous 30-second measurement of the fault (immediate for high pressure), compressor operation is stopped.
- **Freeze Sensing**  
**Note:** For applications using a closed loop antifreeze solution, remove the wire between DI5 and PB2-L1 (see unit schematic). On applications using an open loop/ground water system, make sure the wire is connected.

**Note:** For additional information on the FX10 Control, refer to Application Guide AGFX10, Submittal Data SD1981, or BACnet Protocol Implementation Conformance Statement.

## Operation Logic Data

OPERATION LOGIC	HEATING				COOLING		FAN ON	SL1 - IN ON
	STG1	STG2	STG3	EMERG	STG1	STG2		
<b>SINGLE SPEED UNITS</b>								
Compressor	On	On	On	Off	On	On	-	-
ECM2 Normal	Med	High	High	High	Med	High	Low	-
ECM2 Dehumidify	Med	High	High	High	85% Med	85% High	Low	-
Rev Valve	Off	Off	Off	Off	On	On	-	-
Loop Pump	On	On	On	Off	On	On	-	On
DHW Pump	On	Off	Off	Off	On	On	-	-
Aux Heater	Off	Off	Staged	Staged	Off	Off	-	-
Secondary 1- Out	On	On	On	Off	On	On	-	-
Emerg LED	Off	Off	Off	On	Off	Off	Off	-
T-Stat Signal	Y1	Y1, Y2	Y1, Y2, W	W	Y1, O	Y1, Y2, O	G	-
<b>DUAL CAPACITY UNITS</b>								
Compressor-Lo	On	Off	Off	Off	On	Off	-	-
Compressor-Hi	Off	On	On	Off	Off	On	-	-
ECM2 Normal	Med	High	High	High	Med	High	Low	-
ECM2 Dehumidify	Med	High	High	High	85% Med	85% High	Low	-
Rev Valve	Off	Off	Off	Off	On	On	-	-
Loop Pumps	On	On	On	Off	On	On	-	On
DHW Pump	On	On	Off	Off	On	On	-	-
Aux Heater	Off	Off	Staged	Staged	Off	Off	-	-
Secondary 1- Out	On	On	On	Off	On	On	-	-
Secondary 2- Out	Off	On	On	Off	Off	On	-	-
Emerg LED	Off	Off	Off	On	Off	Off	-	-
T-Stat Signal	Y1	Y1, Y2	Y1, Y2, W	W	Y1, O	Y1, Y2, O	G	-

# Unit Startup

## Before Powering Unit, Check The Following:

**Note:** Remove and discard the two compressor hold down shipping bolts located at the front and rear of the compressor mounting bracket. The bolts can then be discarded.

- High voltage is correct and matches nameplate.
- Fuses, breakers and wire size correct.
- Low voltage wiring complete.
- Piping completed and water system cleaned and flushed.
- Air is purged from closed loop system.
- Isolation valves are open, water control valves or loop pumps wired.
- Condensate line open and correctly pitched.
- Transformer switched to 208V if applicable.
- Black/white and gray/white wires in unit control box have been removed if auxiliary heat has been installed.
- Dip switches are set correctly.
- DHW pump switch is "OFF" unless piping is completed and air has been purged.
- Blower rotates freely – foam shipping support has been removed.
- Blower speed correct (dip switch is set correctly).
- Air filter/cleaner is clean and in position.
- Service/access panels are in place.
- Return air temperature is between 50-80°F heating and 60-95°F cooling.
- Check air coil cleanliness to insure optimum performance. Clean as needed according to maintenance guidelines. To obtain maximum performance the air coil should be cleaned before startup. A 10-percent solution of dishwasher detergent and water is recommended for both sides of coil, a thorough water rinse should follow.

## Startup Steps

**Note:** Complete the Equipment Start-Up/Commissioning Check Sheet during this procedure. Refer to thermostat operating instructions and complete the startup procedure.

1. Initiate a control signal to energize the blower motor. Check blower operation.
2. Initiate a control signal to place the unit in the cooling mode. Cooling setpoint must be set below room temperature.
3. First stage cooling will energize after a time delay. Check for correct rotation of scroll compressors in 3 phase applications. Incorrect rotation will cause low refrigerant pressures and possibly unusual noise. Switch any two power leads at the compressor or contactor to reverse rotation.
4. Be sure that the compressor and water control valve or loop pump(s) are activated.
5. Verify that the water flow rate is correct by measuring the pressure drop through the heat exchanger using the P/T plugs and comparing to unit capacity data in specification catalog.
6. Check the temperature of both the supply and discharge water (see the Unit Operating Parameters tables).
7. Check for an air temperature drop of 15°F to 25°F across the air coil, depending on the fan speed and entering water temperature.
8. Decrease the cooling set point several degrees and verify high-speed blower operation (ECM only).
9. Adjust the cooling setpoint above the room temperature and verify that the compressor and water valve or loop pumps deactivate.
10. Initiate a control signal to place the unit in the heating mode. Heating set point must be set above room temperature.
11. First stage heating will energize after a time delay.
12. Check the temperature of both the supply and discharge water (see the Unit Operating Parameters tables).
13. Check for an air temperature rise of 20°F to 35°F across the air coil, depending on the fan speed and entering water temperature.
14. If auxiliary electric heaters are installed, increase the heating setpoint until the electric heat banks are sequenced on. All stages of the auxiliary heater should be sequenced on when the thermostat is in the Emergency Heat mode. Check amperage of each element.
15. Adjust the heating setpoint below room temperature and verify that the compressor and water valve or loop pumps deactivate.

## Unit Operating Limits

	Cooling		Heating	
	(°F)	(°C)	(°F)	(°C)
<b>Air Limits</b>				
Min. Ambient Air	45	7.2	45	7.2
Rated Ambient Air	80	26.7	70	21.1
Max. Ambient Air	100	37.8	85	29.4
Min. Entering Air	50	10.0	40	4.4
Rated Entering Air db/wb	80.6/66.2	27/19	68	20.0
Max. Entering Air db/wb	110/83	43/28.3	80	26.7
<b>Water Limits</b>				
Min. Entering Water	30	-1.1	20	-6.7
Normal Entering Water	50-110	10-43.3	30-70	-1.1
Max. Entering Water	120	48.9	90	32.2

## Unit Operating Parameters Single Speed Models

Entering Water Temp °F	Water Flow GPM/Ton	Cooling -- No Hot Water Generator					
		Suction Pressure PSIG	Discharge Pressure PSIG	022-070 Superheat	022-070 Subcooling	Water Temp Rise °F	Air Temp Drop °F DB
50	1.5	133 - 148	205 - 225	17 - 26	10 - 14	18 - 22	18 - 22
	3.0	129 - 144	185 - 205	20 - 29	7 - 11	8 - 10	18 - 22
70	1.5	139 - 154	280 - 300	8 - 11	8 - 12	18 - 22	18 - 22
	3.0	137 - 152	250 - 270	9 - 12	7 - 11	8 - 10	18 - 22
90	1.5	143 - 158	360 - 380	8 - 11	9 - 13	18 - 22	16 - 20
	3.0	141 - 156	330 - 350	9 - 12	8 - 12	8 - 10	16 - 20

Entering Water Temp °F	Water Flow GPM/Ton	Heating -- No Hot Water Generator							
		Suction Pressure PSIG	Discharge Pressure PSIG	022-070 Superheat	022-040 Subcooling	048 Subcooling	060-070 Subcooling	Water Temp Drop °F	Air Temp Rise °F DB
30	1.5	73 - 79	279 - 304	7 - 13	2 - 6	11 - 15	4 - 8	7 - 10	18 - 24
	3.0	79 - 85	285 - 310	8 - 14	2 - 6	11 - 15	4 - 8	3 - 6	20 - 26
50	1.5	103 - 109	308 - 333	8 - 12	4 - 8	13 - 17	6 - 10	8 - 11	20 - 26
	3.0	110 - 116	315 - 340	9 - 13	4 - 8	13 - 17	6 - 10	4 - 7	22 - 28
70	1.5	140 - 146	330 - 365	10 - 14	7 - 11	14 - 18	9 - 13	11 - 14	26 - 32
	3.0	146 - 153	340 - 375	10 - 14	7 - 11	14 - 18	9 - 13	7 - 10	28 - 34

Note: Cooling performance based on entering air temperatures of 80° F DB, 67° F WB.  
Heating performance based on entering air temperature of 70° F DB.

# Unit Operating Parameters

## Dual Capacity Models

### FIRST STAGE OPERATION

Entering Water Temp °F	Water Flow GPM/Ton	Cooling -- No Hot Water Generator					
		Suction Pressure PSIG	Discharge Pressure PSIG	Superheat	Subcooling	Water Temp Rise °F	Air Temp Drop °F DB
50	1.5	125-140	205-225	12-20	8-14	17-21	17-23
	3.0	120-135	190-210	12-20	8-14	8-12	17-23
70	1.5	135-145	280-290	10-16	8-14	16-20	17-23
	3.0	133-143	250-260	10-16	8-14	9-13	17-23
90	1.5	142-152	345-355	8-12	8-14	14-20	17-23
	3.0	140-150	330-340	8-12	8-14	8-12	17-23

Entering Water Temp °F	Water Flow GPM/Ton	Heating -- No Hot Water Generator					
		Suction Pressure PSIG	Discharge Pressure PSIG	Superheat	Subcooling	Water Temp Drop °F	Air Temp Rise °F DB
30	1.5	76-84	280-295	8-12	3-10	5-9	12-16
	3.0	80-88	285-300	8-12	3-10	3-7	14-18
50	1.5	100-115	310-330	10-14	3-10	7-11	18-22
	3.0	105-120	315-335	10-14	3-10	5-9	20-24
70	1.5	135-150	325-350	12-16	3-10	8-12	24-28
	3.0	140-155	330-355	12-16	3-10	6-10	22-30

### SECOND STAGE OPERATION

Entering Water Temp °F	Water Flow GPM/Ton	Cooling -- No Hot Water Generator					
		Suction Pressure PSIG	Discharge Pressure PSIG	Superheat	Subcooling	Water Temp Rise °F	Air Temp Drop °F DB
50	1.5	130-140	215-235	12-20	8-14	16-22	17-23
	3.0	128-138	190-210	12-20	8-14	8-12	17-23
70	1.5	138-148	280-310	10-16	10-16	15-21	17-23
	3.0	136-146	250-280	10-16	8-14	7-13	17-23
90	1.5	145-155	350-380	9-14	10-16	14-20	17-23
	3.0	143-153	320-350	9-14	8-14	6-10	17-23

Entering Water Temp °F	Water Flow GPM/Ton	Heating -- No Hot Water Generator					
		Suction Pressure PSIG	Discharge Pressure PSIG	Superheat	Subcooling	Water Temp Drop °F	Air Temp Rise °F DB
30	1.5	73-85	270-305	8-14	3-10	6-10	15-21
	3.0	77-90	280-315	8-14	3-10	4-8	17-23
50	1.5	97-110	290-325	10-16	3-10	9-13	22-28
	3.0	102-115	300-335	10-16	3-10	7-11	24-30
70	1.5	130-145	320-355	13-19	3-10	10-14	30-36
	3.0	135-150	325-360	13-19	3-10	8-12	32-38

Note: Cooling performance based on entering air temperatures of 80° F DB, 67° F WB.

Heating performance based on entering air temperature of 70° F DB.

# Pressure Drop

## Single Speed Models

Model	GPM	Pressure Drop (psi)				
		30°F	50°F	70°F	90°F	110°F
009	1.5	1.9	1.8	1.7	1.6	1.5
	2.0	3.5	3.4	3.2	3.1	3.0
	3.0	6.9	6.5	6.3	6.0	5.7
012	1.5	0.3	0.3	0.3	0.3	0.3
	2.5	1.0	1.0	1.0	1.0	1.0
	3.5	1.7	1.7	1.7	1.6	1.6
015	2.0	0.6	0.6	0.6	0.6	0.6
	3.0	1.6	1.6	1.6	1.6	1.6
	4.0	2.6	2.6	2.6	2.6	2.5
018	3.0	1.6	1.6	1.5	1.5	1.4
	4.0	2.9	2.9	2.8	2.8	2.7
	5.0	4.2	4.2	4.1	4.0	3.9
022	3	0.9	0.9	0.8	0.7	0.7
	4.5	1.7	1.6	1.5	1.4	1.3
	6	2.8	2.7	2.5	2.3	2.2
	8	4.7	4.4	4.1	3.9	3.6
030	4	1.5	1.4	1.3	1.2	1.1
	6	3.0	2.8	2.7	2.5	2.3
	8	5.1	4.8	4.5	4.2	3.9
	10	7.7	7.2	6.8	6.3	5.8
036	5	1.0	1.0	0.9	0.8	0.8
	7	2.1	1.9	1.8	1.7	1.6
	9	3.6	3.3	3.0	2.8	2.6
	12	6.3	5.9	5.5	5.1	4.8
042	5	0.8	0.7	0.7	0.7	0.6
	8	2.1	2.1	1.9	1.8	1.7
	11	4.2	4.1	3.8	3.5	3.3
	14	7.6	6.7	6.3	5.8	5.4
048	6	1.1	1.0	1.0	0.9	0.8
	9	2.3	2.1	2.0	1.9	1.7
	12	3.9	3.7	3.4	3.2	3.0
	16	6.7	6.3	5.9	5.5	5.1
060	9	2.4	2.2	2.1	2.0	1.8
	12	3.9	3.6	3.4	3.2	2.9
	15	5.7	5.3	5.0	4.7	4.3
	20	9.5	8.9	8.3	7.8	7.2
070	12	3.0	2.8	2.6	2.4	2.2
	15	4.4	4.0	3.8	3.5	3.3
	18	6.0	5.5	5.1	4.8	4.4
	24	9.7	9.1	8.5	7.9	7.3

5/25/07

## Dual Capacity Models

Model	GPM	Pressure Drop (psi)				
		30°F	50°F	70°F	90°F	110°F
026 full load	4	1.4	1.3	1.2	1.1	1.0
	6	2.8	2.6	2.4	2.3	2.1
	8	4.7	4.4	4.1	3.8	3.5
	10	7.0	6.6	6.2	5.8	5.3
026 part load	3	0.8	0.7	0.7	0.7	0.6
	5	2.0	1.8	1.7	1.6	1.5
	7	3.6	3.4	3.2	3.0	2.8
038 full load	9	5.8	5.5	5.1	4.8	4.4
	5	1.2	1.2	1.1	1.0	1.0
	7	2.2	2.1	1.9	1.8	1.7
038 part load	9	3.4	3.2	3.0	2.8	2.6
	11	4.9	4.6	4.3	4	3.7
	4	0.9	0.8	0.8	0.7	0.7
	6	1.7	1.6	1.5	1.4	1.3
049 full load	8	2.8	2.6	2.5	2.3	2.1
	10	4.2	3.9	3.7	3.4	3.2
	6	1.2	1.2	1.1	1.0	1.0
	9	2.4	2.2	2.1	2.0	1.8
049 part load	12	3.9	3.6	3.4	3.2	2.9
	15	5.7	5.3	5	4.7	4.3
	5	0.9	0.9	0.8	0.8	0.7
	8	2.0	1.8	1.7	1.6	1.5
064 full load	11	3.4	3.1	2.9	2.8	2.5
	14	5.0	4.7	4.4	4.1	3.8
	8	1.8	1.7	1.6	1.4	1.3
	12	3.8	3.5	3.3	3.0	2.8
064 part load	16	6.5	6.0	5.6	5.2	4.8
	20	9.7	9.1	8.5	8.0	7.4
	6	1.0	0.9	0.9	0.8	0.8
	10	2.6	2.5	2.3	2.1	2.0
072 full load	14	5.0	4.7	4.4	4.1	3.8
	18	8.1	7.6	7.1	6.6	6.1
	12	3.2	3.0	2.8	2.6	2.4
	15	4.5	4.2	4.0	3.7	3.4
072 part load	18	6.0	5.7	5.3	4.9	4.6
	21	7.8	7.3	6.8	6.4	5.9
	10	2.3	2.1	2.0	1.9	1.7
	13	3.6	3.3	3.0	2.8	2.6
070 part load	16	5.0	4.6	4.3	4.0	3.7
	19	6.5	6.2	5.8	5.4	5.0

5/30/06



# Troubleshooting

## Standard Microprocessor Controls

To check the unit control board for proper operation:

- 1) Disconnect thermostat wires at the control board.
- 2) Jumper the desired test input (Y1, Y2, W, O or G) to the R terminal to simulate a thermostat signal.
- 3) If control functions properly:
  - Check for thermostat and field control wiring (use the diagnostic inputs mode).
- 4) If control responds improperly:
  - Ensure that component being controlled is functioning (compressor, blower, reversing valve, etc.).
  - Ensure that wiring from control to the component is functioning (refer to the LED Definition table below and use the diagnostic outputs mode).
  - If steps above check properly, replace unit control.

## LED Definitions and Diagnostics

### Standard Microprocessor

LED	NORMAL DISPLAY MODE		DIAGNOSTIC MODES							
			CURRENT FAULT STATUS		INPUTS		OUTPUTS 1		OUTPUTS 2	
	Field Selection DIPS									
	SW2-	1 On	SW2-	1 Off	SW2-	1 NA	SW2-	1 NA	SW2-	1 NA
	SW2-	6 On	SW2-	6 On	SW2-	6 Off	SW2-	6 On	SW2-	6 Off
	SW2-	7 On	SW2-	7 On	SW2-	7 On	SW2-	7 Off	SW2-	7 Off
<b>Drain</b>	Drain Pan Overflow Lockout		Drain Pan Overflow		Y1		Compressor (On or Low)		Blower Low	
<b>Water Flow</b>	FP Thermistor (Loop <15° F, Well<30°F) Lockout		FP Thermistor (Loop <15° F, Well<30°F)		Y2		Compressor (On or High)		Blower Medium	
<b>High Pressure</b>	High Pressure >600 PSI Lockout		High Pressure >600		O		Reversing Valve		Blower High	
<b>Low Pressure/ Compressor</b>	Low Pressure <40 PSI Lockout or Comfort Alert		Low Pressure <40 or Comfort Alert		G		Fan		Aux Heat 1	
<b>Airflow</b>	ECM2 RPM <100 RPM		ECM2 RPM <100 RPM		W		DHW Pump		Aux Heat 2	
<b>Status</b>	Microprocessor Malfunction		Not Used		SL1		Loop Pump(s)		Aux Heat 3	
<b>DHW Limit</b>	HWL Thermistor >130°		HWL Thermistor >130°F		Not Used		-		Aux Heat 4	
<b>DHW Off</b>	DHW Pump Switch Off		DHW Pump Switch Off		-		-		-	

## Refrigerant Systems

To maintain sealed circuit integrity, do not install service gauges unless unit operation appears abnormal. Compare the change in temperature on the air side as well as the water side to the Unit Operating Parameters tables. If the unit's performance is not within the ranges listed, and the airflow and water flow are known to be correct, gauges should then be installed and superheat and subcooling numbers calculated. If superheat and subcooling are outside recommended ranges, an adjustment to the refrigerant charge may be necessary.

**Note:** Refrigerant tests must be made with desuperheater turned "OFF". Verify that air and water flow rates are at proper levels before servicing the refrigerant circuit.

# Preventive Maintenance

## Water Coil Maintenance

1. Keep all air out of the water. An open loop system should be checked to ensure that the well head is not allowing air to infiltrate the water line. Lines should always be airtight.
2. Keep the system under pressure at all times. It is recommended in open loop systems that the water control valve be placed in the discharge line to prevent loss of pressure during off cycles. Closed loop systems must have positive static pressure.

**Note:** On open loop systems, if the installation is in an area with a known high mineral content (125 PPM or greater) in the water, it is best to establish with the owner a periodic maintenance schedule so the coil can be checked regularly. Should periodic coil cleaning be necessary, use standard coil cleaning procedures which are compatible with either the cupronickel or copper water lines. Generally, the more water flowing through the unit the less chance for scaling.

## Other Maintenance

### Filters

Filters must be clean to obtain maximum performance. They should be inspected monthly under normal operating conditions and be replaced when necessary. Units should never be operated without a filter.

### Condensate Drain

In areas where airborne bacteria produce a slime in the drain pan, it may be necessary to treat chemically to minimize the problem. The condensate drain can pick up lint and dirt, especially with dirty filters. Inspect twice a year to avoid the possibility of overflow.

### Blower Motors

Blower motors are equipped with sealed ball bearings and require no periodic oiling.

### Desuperheater Coil

See Water Coil Maintenance section above.

### Air Coil

The air coil must be cleaned to obtain maximum performance. Check once a year under normal operating conditions and, if dirty, brush or vacuum (with a brush attachment) clean. Care must be taken not to damage the aluminum fins while cleaning.



**CAUTION:** Fin edges are sharp.

# Replacement Procedures

## Obtaining Parts

When ordering service or replacement parts, refer to the model number and serial number of the unit as stamped on the serial plate attached to the unit. If replacement parts are required, mention the date of installation of the unit and the date of failure, along with an explanation of the malfunctions and a description of the replacement parts required.

## In-Warranty Material Return

Material may not be returned except by permission of authorized warranty personnel. Contact your local distributor for warranty return authorization and assistance.



Product: **GS/GT Series**  
Type: Geothermal/Water Source Heat Pumps  
Size: 0.75 thru 6 Ton Single Speed  
2 thru 6 Ton Dual Capacity

Document Type: Installation Manual  
Part Number: IM1000AG1  
Release Date: 09/09