



SPECIFICATION CATALOG

GEO THERMAL HEAT PUMPS



AFFORDABLE RENEWABLE CLEAN



ASTON & ASTON ADVANCED SERIES

Table of Contents

Model Nomenclature	5
AHRI/ISO 13256-1 Performance Ratings	6
Aston Design Features	9
The Aurora™ Control System	13
Operation Logic Data Table	22
Water Quality	22
Dimensional Data	23
Physical Data	27
Auxiliary Heat Ratings	29
Auxiliary Heat Electrical Data	29
Electrical Data	30
Blower Performance Data	32
Reference Calculations	37
Legend and Notes	37
Operating Limits	37
Antifreeze Corrections	38
Correction Factor Tables	39
Pressure Drop	40
Performance Data	41
Wiring Schematics	60
Engineering Guide Specifications	74
Revision Guide	77

ASTON SERIES

Geothermal Heat Pump



GeoStar Aston Series products established a new industry standard for efficiency, performance, reliability and quiet operation. The Aston Series extends this innovation and performance with all new advanced controls and updated performance. The Aston Series is available in nine single speed sizes (1 to 6 ton) with Copeland Scroll™ (rotary in 012 and 018) compressors. The product is also available in five dual capacity sizes (2 to 6 ton) with Copeland Scroll UltraTech™ compressors.

These Aston Series units utilize ozone-safe R-410A refrigerant to meet the most stringent EPA requirements. 5-Speed ECM blower motors bridge the gap of high efficiency ECM capability with great value. ECM blowers are used to increase comfort, efficiency, and airflow flexibility. A new sophisticated Aurora™ Control system is modular and designed to grow with the application. The Aurora 'Base' Control (ABC) features a microprocessor control to sequence all components during operation for optimum performance. Plus, the ABC provides easy-to-use troubleshooting features with fault lights, on-board diagnostics, and a hand held Aurora Interface Diagnostic (AID) Tool. The Aurora 'Advanced' Control adds the Aurora Expansion Board (AXB) to further extend the capability of the system to include compressor current monitoring, advanced loop and hot water generator pump control, as well as service, performance, and energy monitoring sensor kit capability. Unit configurations include vertical top, bottom, or rear discharge (left or right return) and horizontal units with left or right return a side or end discharge. Heavy-gauge metal cabinets are fully insulated and coated with an attractive and durable powder coat paint for long lasting protection.

Aston Series products are performance-certified to AHRI/ISO 13256-1 standards, ETL listed, ENERGY STAR® qualified, and tested in an ISO 17025 accredited testing lab.

As a leader in the industry, we are dedicated to innovation, quality, and customer satisfaction. In fact, every unit built is exposed to a wide range of quality control procedures throughout the assembly process in our ISO 9001:2008 certified manufacturing facility. At the end, it is subjected to a rigorous battery of computerized run tests to certify that it meets or exceeds performance standards for efficiency and safety, and will perform flawlessly at startup. As further affirmation of our quality standards, each unit carries our exclusive Quality Assurance emblem, signed by the final test technician.

Model Nomenclature - Aston

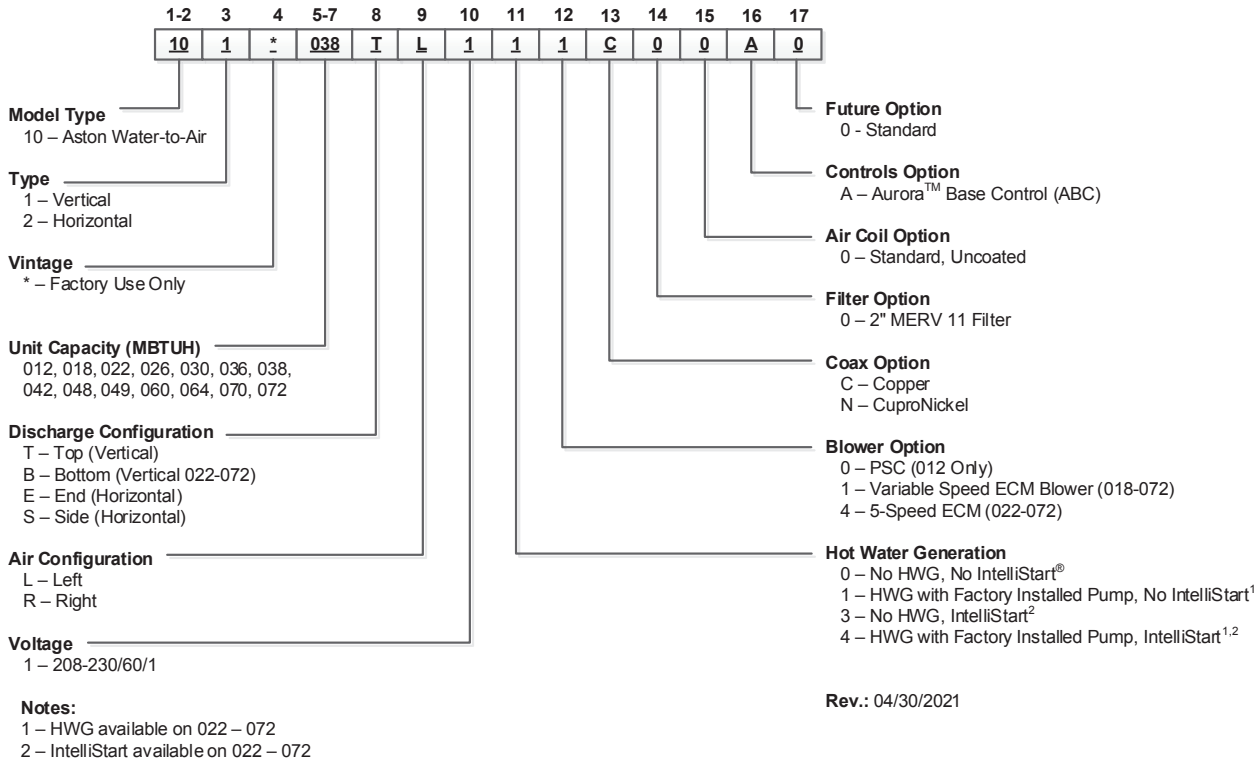

Model Nomenclature - Aston Advanced

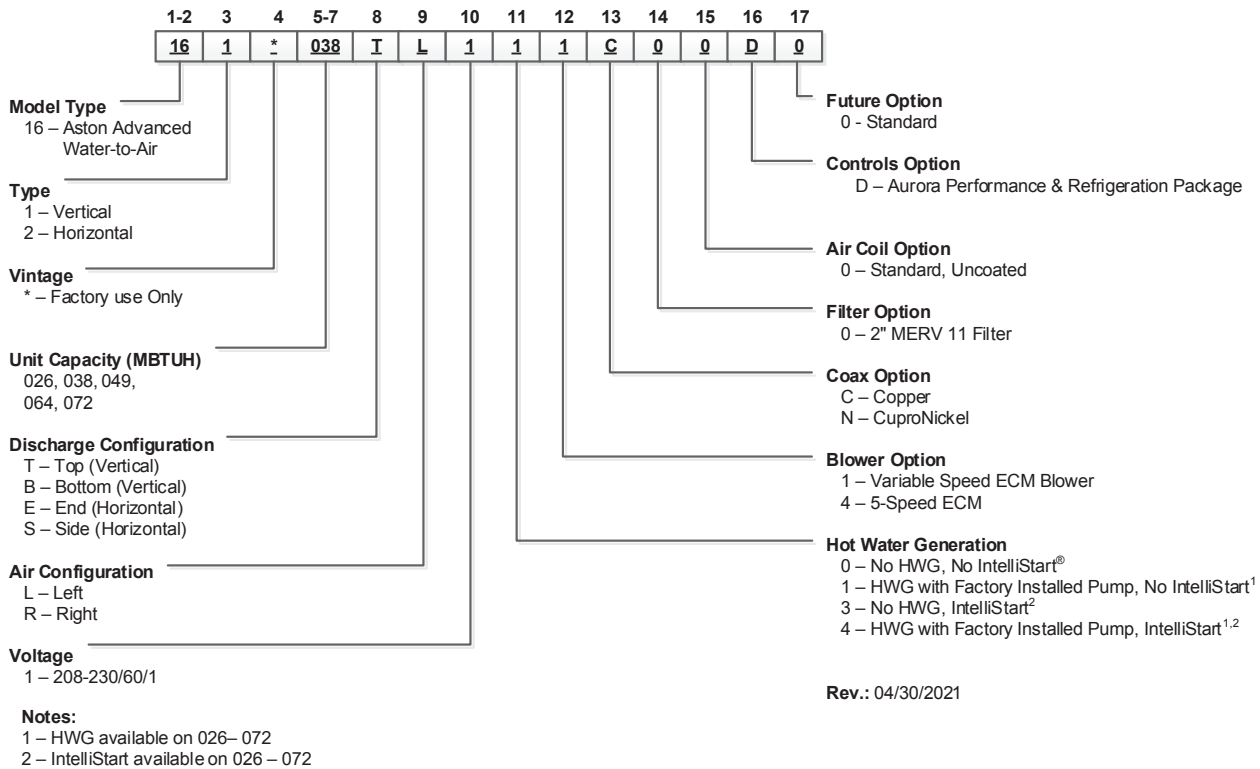

AHRI/ISO 13256-1 Performance Ratings

Variable Speed ECM or 5-Speed ECM Motor

AHRI/ASHRAE/ISO 13256-1

English (IP) Units

Model	Capacity Modulation	Flow Rate		Water Loop Heat Pump				Ground Water Heat Pump				Ground Loop Heat Pump			
				Cooling EWT 86° F		Heating EWT 68° F		Cooling EWT 59° F		Heating EWT 50° F		Cooling Brine Full Load 77° F Part Load 68° F		Heating Brine Full Load 32°F Part Load 41°F	
		gpm	cfm	Capacity Btuh	EER Btuh/W	Capacity Btuh	COP	Capacity Btuh	EER Btuh/W	Capacity Btuh	COP	Capacity Btuh	EER	Heating Capacity	COP
026	Full	8	950	24,900	16.8	30,100	5.5	27,700	24.0	23,900	4.8	26,400	19.6	19,500	4.0
026	Part	7	750	18,900	18.6	22,000	6.1	22,200	29.7	17,500	4.9	21,000	26.0	16,400	4.5
038	Full	9	1300	36,500	17.0	43,300	5.5	40,000	24.4	35,000	4.9	38,200	19.7	28,500	4.2
038	Part	8	1150	26,500	19.0	31,300	6.4	29,900	32.1	24,900	5.1	29,500	28.0	22,900	4.8
049	Full	12	1600	49,100	17.2	59,000	5.5	54,100	24.5	47,200	4.6	50,800	19.3	38,200	4.0
049	Part	11	1400	36,300	19.1	41,700	6.1	41,600	33.0	33,600	4.7	39,800	27.4	31,000	4.4
064	Full	16	1800	62,300	16.4	73,900	5.2	69,000	23.9	60,400	4.6	65,500	19.3	47,300	3.8
064	Part	14	1500	45,800	18.1	53,200	5.9	53,000	30.7	43,500	4.8	50,500	26.5	35,700	4.3
072	Full	18	2000	70,100	15.6	88,000	4.8	79,000	22.0	71,000	4.3	73,800	18.2	55,400	3.7
072	Part	16	1500	54,200	17.0	66,000	5.1	61,500	27.6	52,700	4.3	59,400	24.9	47,400	3.9
018	Single	5	600	17,400	15.7	23,000	5.3	20,600	26.0	18,700	4.6	18,500	18.3	14,500	3.8
022	Single	8	800	18,100	15.6	23,700	6.0	21,900	27.5	19,500	5.0	19,200	18.7	15,000	4.0
030	Single	8	1000	27,000	18.9	32,900	5.6	31,200	29.5	26,000	4.8	28,100	22.0	20,500	3.9
036	Single	9	1200	32,300	18.8	36,500	5.7	36,800	28.8	29,200	4.9	33,700	22.0	24,400	4.2
042	Single	11	1300	39,000	18.6	45,600	5.8	43,900	28.1	36,100	4.9	40,700	21.7	28,900	4.0
048	Single	12	1500	44,100	16.3	55,600	5.4	50,300	25.9	44,700	4.7	45,900	18.8	36,400	4.0
060	Single	15	1800	61,100	16.4	74,100	5.5	66,900	24.3	59,200	4.7	62,200	18.4	47,900	4.0
070	Single	18	2000	66,200	15.3	85,000	5.0	75,000	22.9	68,000	4.4	69,100	17.6	54,000	3.7

NOTE: 018 not available with 5-Speed ECM motor

Cooling capacities based upon 80.6°F DB, 66.2°F WB entering air temperature

Heating capacities based upon 68°F DB, 59°F WB entering air temperature

All ratings based upon 208V operation

7/28/2022

PSC Motors

AHRI/ASHRAE/ISO 13256-1

English (IP) Units

Model	Modulation Capacity	Flow Rate		Water Loop Heat Pump				Ground Water Heat Pump				Ground Loop Heat Pump			
				Cooling EWT 86° F		Heating EWT 68° F		Cooling EWT 59° F		Heating EWT 50° F		Cooling Brine Full Load 77° F Part Load 68° F		Heating Brine Full Load 32°F Part Load 41°F	
		gpm	cfm	Capacity Btuh	EER Btuh/W	Capacity Btuh	COP	Capacity Btuh	EER Btuh/W	Capacity Btuh	COP	Capacity Btuh	EER Btuh/W	Capacity Btuh	COP
012	Single	4	400	11280	14	14800	5	13200	23.1	12000	4.2	12000	16.5	9500	3.5

Cooling capacities based upon 80.6°F DB, 66.2°F WB entering air temperature

Heating capacities based upon 68°F DB, 59°F WB entering air temperature

All ratings based upon 208V operation

7/18/2022

AHRI/ISO 13256-1 Performance Ratings cont.

Energy Star Compliance Table

Model	Tier 3	
	Ground Water	Ground Loop
012	P	P
018	E,	E
022	E, X	E, X
026	E, X	E, X
030	E, X	E, X
036	E, X	E, X
038	E, X	E, X
042	E, X	E, X
048	E, X	E, X
049	E, X	E, X
060	E, X	E, X
064	E, X	E, X
070	E, X	E, X
072	E, X	E, X

7/18/22

E - Unit with Variable Speed ECM Blower
 X - Unit with 5-Speed ECM Blower
 P - Unit with PSC Blower

Energy Star Rating Criteria

In order for water-source heat pumps to be Energy Star rated they must meet or exceed the minimum efficiency requirements listed below. Tier 3 represents the current minimum efficiency water source heat pumps must have in order to be Energy Star rated.

Tier 3: 1/1/2012 = No Effective End Date Published

	EER	GOP
Water-to-Air		
Ground Loop	17.1	3.6
Ground Water	21.1	4.1
Water-to-Water		
Ground Loop	16.1	3.1
Ground Water	20.1	3.5



AHRI/ISO 13256-1 Performance Ratings cont.

The performance standard AHRI/ASHRAE/ISO 13256-1 became effective January 1, 2000 and replaces ARI Standards 320, 325, and 330. This new standard has three major categories: Water Loop (comparable to ARI 320), Ground Water (ARI 325), and Ground Loop (ARI 330). Although these standards are similar there are some differences:

Unit of Measure: The Cooling COP

The cooling efficiency is measured in EER (US version measured in Btu/h per Watt. The Metric version is measured in a cooling COP (Watt per Watt) similar to the traditional COP measurement.

Water Conditions Differences

Entering water temperatures have changed to reflect the centigrade temperature scale. For instance the water loop heating test is performed with 68°F (20°C) water rounded down from the old 70°F (21.1°C).

Air Conditions Differences

Entering air temperatures have also changed (rounded down) to reflect the centigrade temperature scale. For instance the cooling tests are performed with 80.6°F (27°C) dry bulb and 66.2°F (19°C) wet bulb entering air instead of the traditional 80°F (26.7°C) DB and 67°F (19.4°C) WB entering air temperatures. 80.6/66.2 data may be converted to 80/67 using the entering air correction table. This represents a significantly lower relative humidity than the old 80/67 of 50% and will result in lower latent capacities.

Pump Power Correction Calculation

Within each model, only one water flow rate is specified for all three groups and pumping Watts are calculated using the following formula. This additional power is added onto the existing power consumption.

- Pump power correction = (gpm x 0.0631) x (Press Drop x 2990) / 300

Where 'gpm' is waterflow in gpm and 'Press Drop' is the pressure drop through the unit heat exchanger at rated water flow in feet of head.

Blower Power Correction Calculation

Blower power is corrected to zero external static pressure using the following equation. The nominal airflow is rated at a specific external static pressure. This effectively reduces the power consumption of the unit and increases cooling capacity but decreases heating capacity. These Watts are significant enough in most cases to increase EER and COPs fairly dramatically over ARI 320, 325, and 330 ratings.

- Blower Power Correction = (cfm x 0.472) x (esp x 249) / 300

Where 'cfm' is airflow in cfm and 'esp' is the external static pressure at rated airflow in inches of water gauge.

ISO Capacity and Efficiency Calculations

The following equations illustrate cooling calculations:

- ISO Cooling Capacity = Cooling Capacity (Btu/h) + (Blower Power Correction (Watts) x 3.412)
- ISO EER Efficiency (W/W) = ISO Cooling Capacity (Btu/h) x 3.412 / [Power Input (Watts) - Blower Power Correction (Watts) + Pump Power Correction (Watt)]

The following equations illustrate heating calculations:

- ISO Heating Capacity = Heating Capacity (Btu/h) - (Blower Power Correction (Watts) x 3.412)
- ISO COP Efficiency (W/W) = ISO Heating Capacity (Btu/h) x 3.412 / [Power Input (Watts) - Blower Power Correction (Watts) + Pump Power Correction (Watt)]

Comparison of Test Conditions

	ARI 320	ISO/AHRI 13256-1 WLHP	ARI 325	ISO/AHRI 13256-1 GWHP	ARI 330	ISO/AHRI 13256-1 GLHP
Cooling						
Entering Air - DB/WB °F	80/67	80.6/66.2	80/67	80.6/66.2	80/67	80.6/66.2
Entering Water - °F	85	86	50/70	59	77	77
Fluid Flow Rate	*	**	**	**	**	**
Heating						
Entering Air - DB/WB °F	70	68	70	68	70	68
Entering Water - °F	70	68	50/70	50	32	32
Fluid Flow Rate	*	**	**	**	**	**

NOTES: * Flow rate is set by 10°F rise in standard cooling test

** Flow rate is specified by the manufacturer

Part load entering water conditions not shown

WLHP = Water Loop Heat Pump; GWHP = Ground Water Heat Pump; GLHP = Ground Loop Heat Pump

Conversions:

Airflow (lps) = cfm x 0.472;

WaterFlow (lps) = gpm x 0.0631;

ESP (Pascals) = ESP (in wg) x 249;

Press Drop (Pascals) = Press Drop (ft hd) x 2990

Aston Design Features



- ① **COMPRESSOR:** Rotary (012-018), Copeland Scroll™ (022-070 single speed) and Copeland Scroll UltraTech™ (dual capacity) represent the latest technology
- ② **DOUBLE ISOLATED COMPRESSOR:** Double isolated compressor mounting to reduce noise and vibration
- ③ **AURORA CONTROLS & AID TOOL:** Aurora 'Base' Control, Aurora 'Advanced' Control, and Aurora AID Tool
- ④ **OPTIONAL HOT WATER ASSIST:** Provides free hot water in cooling and very high efficiency hot water generation in heating mode
- ⑤ **COAXIAL HEAT EXCHANGER:** Standard large high efficiency copper (optional cupronickel) coax with our exclusive void-free and robotically applied ThermaShield insulation coating
- ⑥ **BALANCED PORT/BIDIRECTIONAL EXPANSION VALVE:** Balanced port bidirectional expansion valve for rock steady superheat control and reliable efficiency and operation at any condition
- ⑦ **AIR COIL:** Large air coil is designed for maximum efficiency, and moisture removal; and provides superior protection from formicary corrosion.
- ⑧ **DISCHARGE MUFFLER:** Helps quiet compressor gas pulsations
- ⑨ **PSC/5-Speed/ECM BLOWER MOTOR OPTIONS:** Choice of PSC (012 only), high efficiency 5-Speed ECM, or high efficiency and ultra-flexible ECM blower motors
- ⑩ **FILTER RACK:** Filter rack holds 1 in. or 2 in. filters (field changeable) with exclusive snap on filter door
- ⑪ **FILTER:** High holding capacity 2 in. pleated MERV 11 filter is standard.
- ⑫ **SWIVEL LOOP CONNECTIONS:** Leak free swivel water connections provide a hand tight gasket connection that easily handles the temperature extremes of geothermal earth loops
- ⑬ **IntelliStart®:** Optional single phase soft starter
- ⑭ **INSULATION:** Cleanable foil lined insulation to prevent mold growth; corrosion resistant composite drain pan
- ⑮ **CABINET FINISH:** Heavy gauge galvanized sheet metal cabinet has 1,000 hr. salt spray rated powder coat paint for long life
- ⑯ **ACCESS PANELS:** Lift out front bottom access panel, lift out panels for easier removal and servicing
- ⑰ **HOT WATER GENERATOR SWITCH & AID TOOL PORT:** Hot water generator switch for easy enabling/disabling of the hot water generator pump; AID Tool port provides quick AID Tool connection

Aston Design Features cont.

What's New?

- Exceptional AHRI/ISO 13256-1 Ratings for traditional geothermal
 - 30 EER and 4.8 COP
- Latest technology compressors
 - LG Rotary in single speed units (sizes 012 and 018)
 - Copeland K5 Scrolls™ in single speed units (sizes 022, 030, 036, 042, 048, 060, 070)
 - Copeland UltraTech™ K5 Compressors in dual capacity units (sizes 026, 038, 049, 064, 072)
- Discharge line mufflers on models 022-072 to help quiet compressor discharge gas pulsations.
- PSC/5-Speed ECM/ECM blower motor options
 - PSC (012 only)
 - 5-Speed ECM for high efficiency (022-072)
 - ECM blower motors for the highest in efficiency and airflow flexibility (018-072)
- Communicating Digital Thermostats: The Aurora controls system features either monochromatic or color touch screen graphic display thermostats for user interface with the Aston system. These displays not only feature easy to use graphical interface but display alerts and faults in plain English.
- Aurora™ Communicating Control Features
 - Traditional Safety Sensors: HP, LP, condensate overflow, freeze detection loop, freeze detection air coil
 - Communicating Modular Design: Communicating modular design for flexibility and expandability
 - Intelligent Hot Water Generator Control: The Aurora Advanced control determines operation of hot water assist dependent upon system parameters to maximize overall system efficiency
 - Loop pump linking: For multiple units on one flow center with either variable speed, single, or dual capacity units (with Aurora Advanced Control); even works with our legacy controls
 - Electric Heat Powered Blower and Controls: Prevents the compressor from tripping out and disabling heat in the house
- Advanced Service Features
 - Aurora Controls with the AID Tool provide advanced service diagnostics. With this device setup and configurations as well as real-time sensors fault and lockout history can be monitored and much more.
 - Complete air flow control throughout the unit's operating range
- Cabinet Design – Improved design of access panels, control box and filter rack
- Cabinet Configurations – Vertical left or right return, downflow left or right return; Horizontal left or right return with either end or side air discharge
- Monitoring Sensor Kits
 - Energy Monitoring: With this standard sensor kit, the Aurora Advanced Control will feature power monitoring of the compressor, blower, and electric heat; the information can be displayed on AID Tool, or selected thermostats

- Refrigerant Monitoring: The Aston features refrigeration service sensors as an optional feature; now superheat, subcooling, refrigerant pressures, and various temperatures needed to diagnose unit problems are readily available at your finger tips in the AID Tool
- Performance Monitoring: With this optional sensor kit installation, the Aurora controls can measure actual capacity and efficiency performance of the heat pump; the information can be displayed on AID Tool
- Cupronickel heat exchanger

Application Flexibility

- Safe, efficient operation in a wide range of liquid temperatures (20°F to 120°F) and flow rates (as low as 1.5 gpm/ton in open loop applications when EWT >50°F)
- Top or rear air discharge for upflow, or bottom discharge for counterflow installations in vertical units, side or end discharge for horizontal units
- True left or right return air locations—vertical units include filter rack/duct collar
- Variable-speed ECM blowers permit various duct applications with flexible airflow selection; optional 5-Speed ECM blower motors provide ECM efficiency at PSC capability; optional PSC motors available on single speed units
- Narrow cabinet for easy movement through doorways
- Internally trapped condensate piping on vertical units for neat, compact installation
- Optional field-installed auxiliary electric heater
- Corner-located electrical box for field wiring from two sides
- Circuit breaker protected loop pump power block for easy wiring
- Relay to control field-mounted accessories
- Field-selectable freeze detection setting for well or closed loop systems
- Loop pump linking feature allows multiple units to share one flow center (requires Aurora 'Advanced' Control option)

Operating Efficiencies

- AHRI/ISO 13256-1 rating for heating COPs, cooling EERs, and low water flow requirements
- Optional hot water generator with internal pump generates hot water at considerable savings while improving overall system efficiency
- High-stability expansion valve delivers optimum refrigerant flow over a wide range of conditions and provides bidirectional operation without troublesome check valves
- Efficient rotary and scroll compressors operate quietly
- Oversized coaxial tube water-to-refrigerant heat exchanger operates at low liquid pressure drops
- Convoluted copper water tube functions efficiently at low flow rates
- Oversized lanced aluminum fin air-to refrigerant heat exchanger provides high efficiencies at low-face velocity with patented 11 element fin design
- Large, low-RPM blowers with ECM or 5-Speed ECM motors

Aston Design Features cont.

provide quiet and efficient air movement with high static capability. Utilizes the ozone-friendly R-410A refrigerant which produces higher efficiencies and warmer discharge air temperatures

Service Advantages

- Removable panels: three for the compressor compartment and one (on horizontals) or two (on verticals) for the air handling compartment to provide quick access to all internal components with ductwork in place
- Easily accessible thermal expansion valve
- Brass, swivel-type water connections for quick connection union, and elimination of wrenches and sealants during installation; sweat type connections are on the hot water generator
- Insulated divider and separate air handling/compressor access panels permit service testing without air bypass
- Designed for front access in tight applications
- LED fault and status lights on the Aurora board with memory for easy diagnostics
- Aurora AID Tool provides enhanced service information via communication directly with the Aurora control including sensor inputs, fault history, and much more
- Detachable thermostat connection strip for wiring convenience
- Hot water pump shut-off switch for easy startup and service
- Control box and blower motors have quick-attach wiring plugs for easy removal
- Internal drop-out blower with permanently-lubricated ball bearing motor
- High- and low-pressure service ports in refrigerant circuit.
- Blower and transformer powered from auxiliary heat supply (when installed) to provide emergency heat with open compressor circuit breaker

Product Quality

- Heavy-gauge steel cabinets are painted with durable powder coat paint for long lasting beauty and service
- Coaxial heat exchanger, refrigerant suction lines, hot water generator coil, and all water pipes are fully insulated to reduce condensation problems in low temperature operation
- Copper tube/aluminum fin air coils are double electro-coated for extended life
- Noise reduction features include double isolation mounted compressors and soft starting blower motors; insulated compressor compartment; interior cabinet insulation using 1/2 in. coated glass fiber; all units include compressor blanket for quiet operation
- Safety features include high- and low-pressure refrigerant controls to protect the compressor, condensate overflow protection, freeze detection sensor to safeguard the coaxial heat exchanger and air coils, blower start detection, hot water high-limit hot water generator pump shutdown, compressor monitoring, and fault lockout enables emergency heat and prevents compressor operation until thermostat or circuit breaker is reset

Microprocessor Benefits

- Communicating monochromatic or color digital auto-changeover thermostat with 3-stage heating/2-stage cooling holds precise temperature and provides varying blower speed control
- Component sequencing delays for quiet startup, shutdown, and timed staging of auxiliary electric heat
- ECM blower speed control provides higher supply air temperature in heating, better dehumidification in cooling, and quiet operation at reduced airflows in all modes
- Hot water limit prevents scalding, and pump shuts down automatically when full unit capacity is needed for heating
- Communication capability for future expansions

Options and Accessories

- Communicating Digital Thermostats
 - *Monochromatic Graphic Display Thermostats:* For user interface with the Aurora system; these displays not only feature easy to use graphical interface but display alerts and faults in plain English. When Energy Monitoring is added, instantaneous usage is displayed on the thermostat itself
 - *Color Touch Screen Graphic Display Thermostats:* For user interface with the Aurora system; these displays not only feature easy to use graphical interface but display alerts and faults in plain English. When Energy Monitoring is added not only instantaneous usage is displayed but also weekly and annual consumptions are stored and graphed. Other features include full color implementation, user loaded background photos, and USB port for easy configuration and software updates
- IntelliZone2 Zone System: The IntelliZone2 zoning system provides up to 6 zones (Variable Speed), 4 zones (Dual Capacity), or 2 zones (Single Speed) of individualized comfort via communication to the Aurora Control System. (AXB required)
- IntelliZone2 • 24V is a non-communicating zoning system that uses a daughter board to translate communication to 24VAC for the heat pump (AXB not required).
- AID Tool: The Aurora Interface and Diagnostics (AID) Tool is a plug-in configuration and troubleshooting tool for the Aurora Control System
- Optional Aurora 'Advanced' Controls (see controls description)
- Optional cupronickel heat exchangers for open loop applications
- Optional hot water generator with internally mounted pump and water heater plumbing connector
- Optional 5-Speed ECM motors available (022-072)
- Electronic auto-changeover thermostat with 3-stage heating/2-stage cooling and indicator LEDs (non-communicating)
- 24 Volt 1 in. electronic air cleaner
- 90% efficient, cleanable electrostatic filters
- Closed loop flow center in several sizes

Aston Design Features cont.

- Auxiliary electric heater
- Hose kits
- Additional accessory relay
- AlpinePure 2 in. MERV 13 filter
- IntelliStart soft starter

Manufacturing Quality

- All units are computer run-tested, with conditioned source water, in all modes to ensure efficiency and reliability
- All refrigerant brazing is performed in a nitrogen atmosphere
- All units are deep evacuated to less than 150 microns prior to refrigerant charging
- All joints are helium leak-tested to ensure an annual leak rate of less than 1/4 ounce
- All major components bar coded; eliminating possibility of mismatched parts built into unit
- All assembly technicians thoroughly trained in proper quality procedures
- All units have model number and serial number embedded in control for local or remote retrieval
- Manufacturing facility is ISO 9001:2008 certified
- Engineering labs are ISO 17025 accredited

The Aurora™ Control System

Aurora ‘Base’ Control

The Aurora ‘Base’ Control (ABC) System is a complete residential and commercial comfort system that brings all aspects of the HVAC system into one cohesive module network. The ABC features microprocessor control and HP, LP, condensate and freeze detection, over/under voltage faults, along with communicating thermostat capability for complete fault detection text at the thermostat.

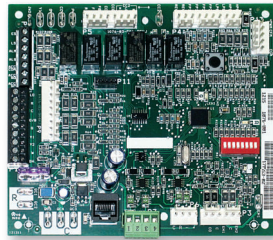

Aurora uses the Modbus communication protocol to communicate between modules. Each module contains the logic to control all features that are connected to the module. The Aurora ‘Base’ Control (ABC) has two Modbus channels. The first channel is configured as a master for connecting to devices such as a communicating thermostat, expansion board, or other slave devices. The second channel is configured as a slave for connecting the Aurora Interface Diagnostics Tool (AID Tool).

Aurora ‘Advanced’ Control

The Aurora ‘Advanced’ Control expands on the capability of the Aurora ‘Base’ Control (ABC) System by adding the Aurora Expansion Board (AXB). The additional features include compressor current monitoring, loop pump slaving, intelligent hot water generator control, variable speed pump capability, and also allows for optional energy, refrigeration, and performance monitoring factory installed add-on sensor kits. The AXB also features a second field configurable accessory relay, and two home automation inputs that are AID configurable for different types of alarms from sump pumps to home security. The Smart Grid input is AID configurable with many options to react to Utility controlled relay operation for ON Peak optimization. The AXB also expands the communication capability for IntelliZone2 ready operation as well as other expansion with the ClimateTalk protocol.

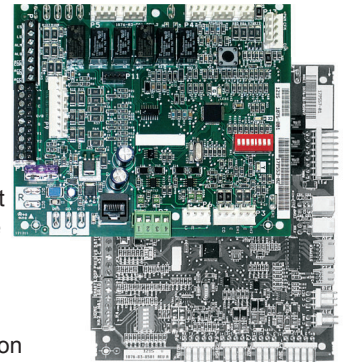





Aurora Control Features	Description	Aurora ‘Base’	Aurora ‘Advanced’
Microprocessor Compressor Control	Microprocessor control of compressor for timings with FP1, HP, LP, Condensate, assignable Acc relay	•	•
Advanced Microprocessor Features	Smart Grid, Home Automation Alarm Inputs, and Accessory2 Relay (HRV/ERV)	-	•
Base Hot Water Generator Operation	Compressor Contactor powers Hot Water Generator Pump with inline circuit breaker and thermostat limit.	•	See below
Advanced Hot Water Generator Control	Microprocessor and separate power relay for Hot Water Generator Pump with digital temperature monitoring and multiple HWG setpoint selection.	-	•
Base Loop Pump Control	Compressor Contactor powers Loop Pump with inline circuit breaker and no loop pump slaving capability.	•	See below
Advanced Speed Pump Control	Microprocessor and separate power relay for loop pump and inline circuit breakers and loop pump slaving.	-	•
Variable Speed Pump	Capable of setup, monitoring and controlling a variable speed flow center.	-	•
Compressor Monitoring	Control monitors compressor starts for high current, missing leg etc.	-	•
Active Dehumidification	Coil temperature is monitored and air flow is reduced for maximum latent moisture removal.	-	Sycamore Series Variable Speed Only
Smart Grid/Utility Input	Allows simple input to externally enable of occupied/unoccupied mode for basic utility time of use programs.	-	Dry Contact x1
Home Automation Alarm Input	Allows simple input to signal sump, security, or smoke/CO sensor alarms from other home automation or security systems. The two inputs can be field configured to a number of options and logic.	-	Dry Contact x2
IntelliZone® Compatibility	IntelliZone requires traditional TStat inputs. IntelliZone2 communicates to the heat pump via the AXB board.	With Optional AXB kit and IntelliZone2	Optional IntelliZone2
IntelliZone2 • 24V Compatibility	Communicates to the heat pump via 24VAC (AXB not required)	•	-

The Aurora Control System cont.

Service Device	Description	Aurora 'Base'	Aurora 'Advanced'
 <p>Aurora Interface and Diagnostics (AID) Tool</p>	<p>Allows setup, monitoring and troubleshooting of any Aurora Control.</p> <p>NOTE: Although the ABC has basic compatibility with all Aurora, new product features may not be available on older AID Tools. To simplify the basic compatibility ensure the version of AID is at least the same or greater than the ABC software version.</p>	For Service (Ver. 1.xx or greater)	For Service (Ver. 2.xx or greater)

Add On Control Feature Kits (field or factory Installed)	Description	Aurora 'Base'	Aurora 'Advanced'
Geo Energy Monitoring Kit	Monitors realtime power consumption of compressor, blower, aux heat and pump. Requires thermostat TPCM32U03GSR, TPCM32U04GSR, or TPCC32U02GSR. AXB required.	-	Standard
Refrigeration Monitoring Kit	Monitors realtime pressures, temperatures, superheat, and subcooling. AXB required.	-	Optional Sensor Kit
Performance Monitoring Kit	Monitors air and water temperatures, and water flow rate and calculates heat of extraction/rejection. AXB required.	-	Optional Sensor Kit
AXB Kit for advanced hot water generator control, flow center linking, variable speed pump, IntelliZone2	Added to Aston Series for key features of advanced hot water generator control, advanced loop control/linking, IntelliZone2 communication, and variable speed pump control.	Optional (field Kit)	Standard

Add On Thermostats and Zoning	Description	Aurora 'Base'	Aurora 'Advanced'
 <p>TP32U03GSR/04GSR - MonoChrome Traditional Y1, Y2 Thermostat</p>	Elite Stat with full English fault codes and alerts, traditional Y1, Y2 thermostat	Optional	Optional
 <p>TP32S01GSR/02GSR - Traditional Y1, Y2 Thermostat</p>	Traditional Y1, Y2 thermostat	Optional	Optional
 <p>TPCM32U03AGSR/04AGSR - MonoChrome Communicating Thermostat</p>	Elite Stat with full English fault codes and alerts, communicating thermostat. Monochrome thermostat allows instantaneous energy measurement only.	Optional	Optional
 <p>TPCC32U02GSR - Color Touchscreen Communicating Thermostat</p>	4.3 in. color touchscreen communicating thermostat with full English fault codes and alerts. Color thermostat allows instantaneous and 13 month history.	Optional	Optional
IntelliZone2 • 24V ZoningCompatibility	IntelliZone2 • 24V is a non-communicating zoning system requiring Y1, Y2 signals that controls up to 4 zones (dual capacity) and 2 zones (single speed). For heat pumps without the optional AXB board.	Optional (5 Speed ECM or Variable Speed ECM Preferred)	Optional (IntelliZone2 Preferred)
 <p>IntelliZone2® Zoning</p>	Includes color main thermostat and up to 6 zones (with variable speed), 4 zones (with dual capacity), and 2 zones (with single speed). There are 3 thermostat options (MasterStat, SensorStat, ZoneStat). Requires AXB.	-	Optional (IntelliZone2 Preferred)

The Aurora ‘Base’ Control System cont.

Aurora ‘Base’ Control

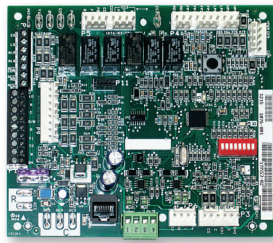

NOTE: Refer to the Aurora Base Control Application and Troubleshooting Guide and the Instruction Guide: Aurora Interface and Diagnostics (AID) Tool for additional information.

Control Features

Software ABC Standard Version 3.0

Single or Dual Capacity Compressors

Either single or dual capacity compressors can be operated.

ECM Blower Motor Option

An ECM blower motor can be driven directly using the onboard PWM output. Four blower speeds are available based upon the G, Y1, Y2, and W input signals to the board. The blower speeds can be changed either by the ECM manual configurations mode method or by using the Aurora AID Tool directly. All four blower speeds can be set to the same speed if desired.

5-Speed ECM Blower Motor Option

A 5-Speed ECM blower motor will be driven directly using the thermostat connections. Any of the G, Y1, or Y2/W signals can drive any of the 5 available pre-programmed blower speeds on the motor.

Other Control Features

- Random start at power up
- Anti-short cycle protection
- High and low pressure cutouts
- Loss of charge
- Water coil freeze detection
- Air coil freeze detection
- Over/under voltage protection
- Condensate overflow sensor
- Load shed
- Dehumidification (where applicable)
- Emergency shutdown
- Hot gas reheat operation (where applicable)
- Diagnostic LED
- Test mode push button switch
- Two auxiliary electric heat outputs
- Alarm output
- Accessory output with N.O. and N.C.
- Modbus communication (master)
- Modbus communication (slave)

Field Selectable Options via Hardware

DIP Switch (SW1) – Test/Configuration Button (See SW1 Operation Table)

Test Mode

The control is placed in the test mode by holding the push button switch SW1 for 2 - 5 seconds. In test mode most of the control timings will be shortened by a factor of sixteen (16). LED3 (green) will flash at 1 second on and 1 second off. Additionally, when entering test mode LED1 (red) will flash the last lockout one time. Test mode will automatically time out after 30 minutes. Test mode can be exited by pressing and holding the SW1 button for 2 to 5 seconds or by cycling the power. **NOTE:** Test mode will automatically be exited after 30 minutes.

Variable Speed ECM Configuration Mode

The control is placed in the ECM configuration mode by holding the pushbutton switch SW1 for 5 to 10 seconds, the high, low, and “G” ECM speeds can be selected by following the LED display lights. LED2 (yellow) will fast flash when entering the ECM configuration. When setting “G” speed LED3 (green) will be continuously lit, for low speed LED1 (red) will be continuously lit, and for high speed both LED3 (green) and LED1 (red) will be continuously lit. During the ECM configuration mode LED2 (yellow) will flash each of the 12 possible blower speeds 3 times. When the desired speed is flashed press SW1, LED2 will fast flash until SW1 is released. “G” speed has now been selected. Next select low speed, and high speed blower selections following the same process above. After third selection has been made, the control will exit the ECM configuration mode. Aux fan speed will remain at default or current setting and requires the AID Tool for adjustment.

Reset Configuration Mode

The control is placed in reset configuration mode by holding the push button switch SW1 for 50 to 60 seconds. This will reset all configuration settings and the EEPROM back to the factory default settings. LED3 (green) will turn off when entering reset configuration mode. Once LED3 (green) turns off, release SW1 and the control will reset.

DIP Switch (SW2)

- SW2-1** FP1 Selection – Low water coil temperature limit setting for freeze detection. On = 30°F; Off = 15°F.
- SW2-2** FP2 Selection – On = 30°F; Off = N/A
- SW2-3** RV – O/B - thermostat type. Heat pump thermostats with “O” output in cooling or “B” output in Heating can be selected. On = O; Off = B.
- SW2-4** Access Relay Operation (P2)

Access Relay Operation	SW2-4	SW2-5
Cycle with Blower	ON	ON
Cycle with Compressor	OFF	OFF
Water Valve Slow Opening	ON	OFF
Cycle with Comm. T-stat Hum Cmd	OFF	ON

The Aurora 'Base' Control System cont.

Cycle with Blower - The accessory relay will cycle with the blower output.

Cycle with Compressor - The accessory relay will cycle with the compressor output.

Water Valve Slow Opening - The accessory relay will cycle and delay both the blower and compressor output for 90 seconds.

- SW2-6** CC Operation – selection of single or dual capacity compressor. On = Single Stage; Off = Dual Capacity
- SW2-7** Lockout and Alarm Outputs (P2) – selection of a continuous or pulsed output for both the LO and ALM Outputs. On = Continuous; Off = Pulsed
- SW2-8** Future Use

Alarm Jumper Clip Selection

From the factory, ALM is connected to 24 VAC via JW2. By cutting JW2, ALM becomes a dry contact connected to ALG.

Variable Speed ECM Blower Speeds

The blower speeds can be changed either by using the ECM manual configurations mode method or by using the Aurora AID Tool directly (see Instruction Guide: Aurora Interface and Diagnostics (AID) Tool topic).

Field Selectable Options via Software

(Selectable via the Aurora AID Tool)

Variable Speed ECM Blower Speeds

An ECM blower motor can be driven directly using the onboard PWM output. Four blower speeds are available, based upon the "G", Y1 (low), Y2 (high), and Aux input signals to the board. The blower speeds can be changed either by the ECM manual configurations mode method (see ECM Configuration Mode topic) or by using the Aurora AID Tool directly. All four blower speeds can be set to the same speed if desired. Aux blower speed will remain at default or current setting and requires the AID Tool for adjustment.

Safety Features

The following safety features are provided to protect the compressor, heat exchangers, wiring and other components from damage caused by operation outside of design conditions.

Fuse – a 3 amp automotive type plug-in fuse provides protection against short circuit or overload conditions.

Anti-Short Cycle Protection – 4 minute anti-short cycle protection for the compressor.

Random Start – 5 to 80 second random start upon power up.

Fault Retry – in the fault condition, the control will stage off the outputs and then "try again" to satisfy the thermostat Y input call. Once the thermostat input calls are satisfied, the control will continue on as if no fault occurred. If 3 consecutive faults occur without satisfying the thermostat Y input call, then the control will go to Lockout mode.

Lockout – when locked out, the blower will operate continuously in "G" speed, and PSC blower motor output will remain on. The Alarm output (ALM) and Lockout output (L) will be turned on. The fault type identification display LED1 (Red) shall flash the fault code. To reset lockout conditions with SW2-8 On, thermostat inputs "Y1", "Y2", and "W" must be removed for at least 3 seconds. To reset lockout conditions with SW2-8 Off, thermostat inputs "Y1", "Y2", "W", and "DH" must be removed for at least 3 seconds. Lockout may also be reset by turning power off for at least 30 seconds or by enabling the emergency shutdown input for at least 3 seconds.

Lockout With Emergency Heat - if the control is locked out in the heating mode, and a Y2 or W input is received, the control will operate in the emergency heat mode while the compressor is locked out. The first emergency heat output will be energized 10 seconds after the W input is received, and the blower will shift to high speed. If the control remains locked out, and the W input is present, additional stage of emergency heat will stage on after 2 minutes. When the W input is removed, all of the emergency heat outputs will turn off, and the ECM blower will shift to "G" speed and PSC blower motor output will remain on.

High Pressure – fault is recognized when the Normally Closed High Pressure Switch, P4-9/10 opens, no matter how momentarily. The High Pressure Switch is electrically in series with the Compressor Contactor and serves as a hard-wired limit switch if an overpressure condition should occur.

Low Pressure - fault is recognized when the Normally Closed Low Pressure Switch, P4-7/8 is continuously open for 30 seconds. Closure of the LPS any time during the 30 second recognition time restarts the 30 second continuous open requirement. A continuously open LPS shall not be recognized during the 2 minute startup bypass time.

Loss of Charge – fault is recognized when the Normally Closed Low Pressure Switch, P4-7/8 is open prior to the compressor starting.

Condensate Overflow - fault is recognized when the impedance between this line and 24 VAC common or chassis ground drops below 100K ohms for 30 seconds continuously.

Freeze Detection (Coax) - set points shall be either 30°F or 15°F. When the thermistor temperature drops below the selected set point, the control shall begin counting down the 30 seconds delay. If the thermistor value rises above the selected set point, then the count should reset. The resistance value must remain below the selected set point for the entire length of the appropriate delay to be recognized as a fault. This fault will be ignored for the initial 2 minutes of the compressor run time.

Freeze Detection (Air Coil) - uses the FP2 input to protect against ice formation on the air coil. The FP2 input will operate exactly like FP1 except that the set point is 30 degrees and is not field adjustable.

The Aurora 'Base' Control System cont.

Over/Under Voltage Shutdown - An over/under voltage condition exists when the control voltage is outside the range of 18 VAC to 30 VAC. If the over/under voltage shutdown lasts for 15 minutes, the lockout and alarm relay will be energized. Over/under voltage shutdown is self-resetting in that if the voltage comes back within range of 18 VAC to 30 VAC for at least 0.5 seconds, then normal operation is restored.

Operation Description

Power Up - The unit will not operate until all the inputs and safety controls are checked for normal conditions. The unit has a 5 to 80 second random start delay at power up. Then the compressor has a 4 minute anti-short cycle delay after the random start delay.

Standby In standby mode, Y1, Y2, W, DH, and G are not active. Input O may be active. The blower and compressor will be off.

Heating Operation

Heating, 1st Stage (Y1) - The blower is started on "G" speed immediately and the compressor is energized 10 seconds after the Y1 input is received. The ECM blower motor is switched to low speed 15 seconds after the Y1 input.

Heating, 2nd Stage (Y1, Y2) - The compressor will be staged to full capacity 20 seconds after Y2 input is received. The ECM blower will shift to high speed 15 seconds after the Y2 input is received.

Heating, 3rd Stage (Y1, Y2, W) - The hot water pump is de-energized and the first stage of electric heat is energized 10 seconds after the W command is received. If the demand continues the second stage of electric heat will be energized after 5 minutes.

Emergency Heat (W) - The blower will be started on "G" speed, 10 seconds later the first stage of electric heat will be turned on. 5 seconds after the first stage of electric heat is energized the blower will shift to Aux speed. If the emergency heat demand is not satisfied after 2 minutes the second electric heat stage will be energized.

Blower (G) - The blower will start immediately upon receiving a thermostat G command. If there are no other commands from the thermostat the ECM will run on "G" speed until the G command is removed. Regardless of blower input (G) from the thermostat, the blower will remain on for 30 seconds at the end of each heating cycle.

Cooling Operation

In all cooling operations, the reversing valve directly tracks the O input. Thus, anytime the O input is present, the reversing valve will be energized.

Cooling, 1st Stage (Y1, O) - The blower is started on "G" speed immediately and the compressor is energized 10 seconds after the Y1 input is received. The ECM blower motor is switched to low speed 15 seconds after the Y1 input.

Cooling, 2nd Stage (Y1, Y2, O) - The compressor will be staged to full capacity 20 seconds after Y2 input is received. The ECM blower will shift to high speed 15 seconds after the Y2 input is received.

Blower (G) - The blower will start immediately upon receiving a thermostat G command. If there are no other commands from the thermostat the ECM will run on "G" speed until the G command is removed. Regardless of blower input (G) from the thermostat, the blower will remain on for 30 seconds at the end of each heating, cooling, and emergency heat cycle.

Dehumidification (Y1, O, DH or Y1, Y2, O, DH) - When a DH command is received from the thermostat during a compressor call for cooling the ECM blower speed will be reduced by 15% to increase dehumidification.

Emergency Shutdown - Four (4) seconds after a valid ES input, P2-7 is present, all control outputs will be turned off and remain off until the emergency shutdown input is no longer present. The first time that the compressor is started after the control exits the emergency shutdown mode, there will be an anti-short cycle delay followed by a random start delay. Input must be tied to common to activate.

Continuous Blower Operation - The blower output will be energized any time the control has a G input present, unless the control has an emergency shutdown input present. The blower output will be turned off when G input is removed.

Load Shed - The LS input disables all outputs with the exception of the blower output. When the LS input has been cleared, the anti-short cycle timer and random start timer will be initiated. Input must be tied to common to activate.

The Aurora ‘Base’ Control System cont.

Aurora ‘Base’ Control LED Displays

These three LEDs display the status, configuration, and fault codes for the control. These can also be read in plain English via the Aurora AID Tool.

Status LED (LED3, Green)

Description of Operation	Fault LED, Green
Normal Mode	ON
Control is Non-functional	OFF
Test Mode	Slow Flash
Lockout Active	Fast Flash
Dehumidification Mode	Flash Code 2
(Future Use)	Flash Code 3
(Future Use)	Flash Code 4
Load Shed	Flash Code 5
ESD	Flash Code 6
(Future Use)	Flash Code 7

Configuration LED (LED2, Yellow)

Description of Operation	Configuration LED, Yellow
No Software Overwritten	Flashing ECM Setting
DIP Switch was Overwritten	Slow Flash
ECM Configuration Mode	Fast Flash

Fault LED (LED1, Red)

Red Fault LED		LED Flash Code*	Lockout	Reset/Remove
ABC Basic Faults	Normal - No Faults	OFF	–	
	Fault - Input	1	No	Auto
	Fault - High Pressure	2	Yes	Hard or Soft
	Fault - Low Pressure	3	Yes	Hard or Soft
	Fault - Freeze Detection FP2	4	Yes	Hard or Soft
	Fault - Freeze Detection FP1	5	Yes	Hard or Soft
	Fault - Condensate Overflow	7	Yes	Hard or Soft
	Fault - Over/Under Voltage	8	No	Auto
	Fault - FP1 Sensor Error	11	Yes	Hard or Soft
	Fault - CritComErr	19	NO	Auto

NOTE: All codes >11 use long flash for tens digit and short flash for the ones digit. 20, 30, 40, 50, etc. are skipped.

Aurora Interface and Diagnostics (AID) Tool

The Aurora Interface and Diagnostics (AID) Tool is a device that is a member of the Aurora network. The AID Tool is used to troubleshoot equipment which uses the Aurora control via Modbus RTU communication. The AID Tool provides diagnostics, fault management, variable speed ECM setup, and system configuration capabilities to the Aurora family of controls. An AID Tool is recommended, although not required, for ECM airflow settings. The AID Tool simply plugs into the exterior of the cabinet in the AID Tool port.



ABC Control Board Layout

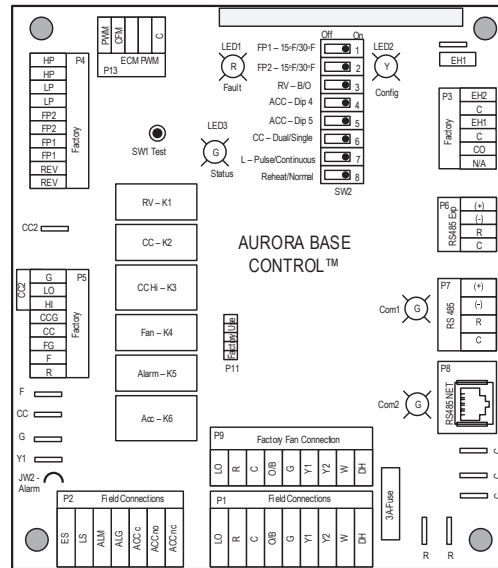

The Aurora 'Advanced' Control System

Aurora 'Advanced' Control Features

The Aurora 'Advanced' Control system expands on the capability of the Aurora 'Base' Control (ABC) by adding the Aurora Expansion Board (AXB). All of the preceding features of the Aurora 'Base' Control are included. The following control description is of the additional features and capability of the advanced control.

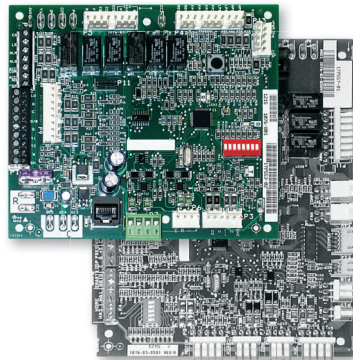

It is highly recommended the installing/servicing contractor obtain an Aurora Interface and Diagnostic Tool (AID) and specialized training before attempting to install or service an Aurora 'Advanced' control system.



The additional AXB features include the following:

AXB DIP Switch

- DIP 1 - ID:** This is the AXB ModBus ID and should always read On.
- DIP 2 & 3 - Future Use**
- DIP 4 & 5 - Accessory Relay2:** A second, DIP configurable, accessory relay is provided that can be cycled with the compressor 1 or 2, blower, or the Dehumidifier (DH) input. This is to complement the Accessory 1 Relay on the ABC board.

Position	DIP 4	DIP 5	Description
1	ON	ON	Cycles with Fan or ECM (or G)
2	OFF	ON	Cycles with CC1 first stage of compressor or compressor spd 1-6
3	ON	OFF	Cycles with CC2 second stage of compressor or compressor spd 7-12
4	OFF	OFF	Cycles with DH input from ABC board

Advanced Hot Water Generator Control (Domestic Hot Water Option)

In lieu of the 'Base Hot Water Generator Control', the Advanced features an AID Tool selectable temperature limit and microprocessor control of the process. This will maximize hot water generation and prevent undesirable energy use. An alert will occur when the hot water input temperature is at or above setpoint (100°F - 140°F) for 30 continuous seconds (130°F is the default setting). This alert will appear as an E15 on the AID Tool and the hot water pump de-energizes. Hot water pump operations resume on the next compressor cycle or after 15 minutes of continuous compressor operation during the current thermostat demand cycle. Since compressor hot gas temperature is dependent on loop temperature in cooling mode, loop temperatures may be too low to allow proper heating of water. The control will monitor water and refrigerant temperatures to determine if conditions are satisfactory for heating water. LED1 (red LED) will flash code 15 when the DHW

limit is reached and when conditions are not favorable for water heating. Error code 15 will also be displayed on the AID Tool in the fault screen. This flash code is a noncritical alert and does not necessarily indicate a problem.

Compressor Monitoring

The AXB includes two current transducers to monitor the compressor current and starting characteristics. Open circuits or welded contactor faults will be detected. A fault will produce an E10 code.

IntelliZone2 Zoning Compatibility (Optional IntelliZone2 Communicating Zoning)

A dedicated input to connect and communicate with the IntelliZone2 (IZZ) zoning system is provided on P7 on the AXB. This is a dedicated communication port using a proprietary ModBus protocol. An AXB is required. Consult the IntelliZone2 literature for more information.

Variable Speed Pump

This input and output are provided to drive and monitor a variable speed pump. The VS pump output is a PWM signal to drive the variable speed pump. The minimum and maximum level are set using the AID Tool. 75% and 100% are the default settings respectively. The VS data input allows a separate PWM signal to return from the pump giving fault and performance information. Fault received from the variable speed pump will be displayed as E16.

Modulating Water Valve

This output is provided to drive a modulating water valve. Through advanced design the 0-10VDC valve can be driven directly from the VS pump output. The minimum and maximum level are set in the same way as the VS pump using the AID Tool. 75% and 100% are the default settings respectively.

Loop Pump Linking

This input and output are provided so that two units can be linked together with a common flow center. When either unit has a call for loop pump, both unit's loop pump relays and variable speed pumps are energized. The flow center then can simply be wired to either unit. The output from one unit should be routed to the input of the other. If daisy chained up to 16 heat pumps can be wired and linked together in this fashion.

Advanced Communication Ports

Communication ports P6 and P8 will provide future expansion via dedicated protocols. These are for future use.

Smart Grid-On Peak (SG) Input

The 'On Peak' input was designed to allow utilities to utilize simple radio controlled switches to control the On Electric Peak behavior of the Aston and Sycamore Geothermal Heat Pump. With a closed contact signal, this input will limit the operation and thus the power consumption of the unit by one of the below selections.

The Aurora ‘Advanced’ Control System cont.

The AID Tool will allow configuration of this input for the action of:

- No Action
- Disable compressor operation until removed
- Go to On Peak thermostat settings until removed [Requires Com T-Stat] (Future Release)
- Compressor limited to 50% or low cap until removed [dual capacity or variable speed only] (Future Release)
- Disable compressor operation for 1/2 hr (can be removed immediately) (Future Release)

Then Flash Code 7 on the Green LED for the 'On Peak' mode. And On Peak will display on communicating thermostats.

Home Automation 1 and 2 Inputs

The Home automation inputs are simple closed contact inputs that will trigger an AID Tool and thermostat alert for the homeowner.

These would require optional sensors and or equipment for connection to the AXB board. With two inputs two different sensors can be selected. The selected text will then be displayed on the AID Tool and communicating thermostats. These events will NOT alter functionality or operation of the heat pump/accessories and is for homeowner/service notification only.

Home Automation 1 - E23 HA1

With a closed dry contact signal, this input will cause an alarm and Alert Code 23 to indicate on the stat or flash on ABC. The AID Tool will allow configuration of this input between the following selections:

- No Action
- Home Automation Fault [no lockout info only]
 - Output from home automation system
- Security Alarm [no lockout info only]
 - Output from home security
- Sump Alarm Fault [no lockout info only]
 - Switch output from sump sensor
- Smoke/CO Alarm Fault [no lockout info only]
 - Switch output from Smoke/CO sensor
- Dirty Filter Alarm [no lockout info only]
 - Output from dirty filter sensor

Home Automation 2 – E24 HA2

With a closed dry contact signal, this input will cause an alarm and Alert Code 24 to indicate on the stat or flash on ABC. The AID Tool will allow configuration of this input between the following selections:

- No Action
- Home Automation Fault [no lockout info only]
 - Output from home automation system
- Security Alarm [no lockout info only]
 - Output from home security
- Sump Alarm Fault [no lockout info only]
 - Switch output from sump sensor
- Smoke/CO Alarm Fault [no lockout info only]
 - Switch output from Smoke/CO sensor
- Dirty Filter Alarm [no lockout info only]
 - Output from dirty filter sensor

Monitoring Sensor Kits

Energy Monitoring (Standard Sensor Kit on ‘Advanced’ models)

The Energy Monitoring Kit includes two current transducers (blower and electric heat) added to the existing two compressor sensors so that the complete power usage of the heat pump can be measured. The AID Tool provides configuration detail for the type of blower motor, power adjustment and a line voltage calibration procedure to improve the accuracy, and a power adjustment setting that allows the compressor power to be adjusted to match the unit's line voltage using the provided tables. This information can be displayed on the AID Tool or selected communicating thermostats. The TPCM32U03AGSR/04AGSR will display instantaneous energy use while the color touchscreen TPCC32U02GSR will in addition display a 13 month history in graph form. Refer to Unit Start Up Energy Monitoring for configuration details.

Single Speed Power Adjustment

Model	Voltage		
	208	230	250
012	0.99	0.98	0.97
018	0.99	0.97	0.96
022	0.99	0.99	0.95
030	0.99	0.99	0.94
036	0.99	0.99	0.93
042	0.99	0.98	0.92
048	0.99	0.97	0.90
060	0.98	0.96	0.87
070	0.96	0.88	0.85

Dual Capacity Power Adjustment

Model	Unit Capacity	Voltage		
		208	230	250
026	Full Load	0.99	0.99	0.96
	Part Load	0.99	0.99	0.93
038	Full Load	0.99	0.97	0.91
	Part Load	0.99	0.94	0.83
049	Full Load	0.94	0.91	0.85
	Part Load	0.91	0.84	0.75
064	Full Load	0.95	0.9	0.79
	Part Load	0.92	0.83	0.71
072	Full Load	0.94	0.86	0.73
	Part Load	0.92	0.81	0.65

Refrigerant Monitoring (optional sensor kit)

The optional Refrigerant Monitoring Kit includes two pressure transducers, and three temperature sensors, heating liquid line, suction temperature and existing cooling liquid line (FP1). These sensors allow the measurement of discharge and suction pressures, suction and liquid line temperatures as well as superheat and subcooling. This information will only be displayed on the AID Tool.

Performance Monitoring (optional sensor kit)

The optional Performance Monitoring Kit includes three temperature sensors, entering and leaving water, leaving air temperature and a water flow rate sensor. With this kit heat of extraction and rejection will be calculated. This requires configuration using the AID Tool for selection of water or antifreeze.

The Aurora ‘Advanced’ Control System cont.

Special Modes and Applications

5-Speed ECM Blower Motor

Normally the 5-Speed ECM motor can be driven off of thermostat signals and the ABC connector P9. Communicating thermostats, however present a special problem in this application since they operate without 24 VAC thermostat signals. The ABC board is wired to operate these systems from the alternate relay output signals CC1, CC2, Fan, and EH1 and should be wired for this.

Communicating Digital Thermostats

The Aurora controls system also features either mono-chromatic or color touch screen graphic display thermostats for user interface. These displays not only feature easy to use graphical interface but display alerts and faults in plain English. Many of the features discussed here may not be applicable without these thermostats.

Dehumidification – Passive

In passive dehumidification mode, the airflow is reduced by 15% from the heating airflow setting. If cooling airflow is set to +5, -5 or -10% of heating airflow it will automatically be set to -15% of heating airflow whenever the dehumidification call is present in the communicating stat or from the thermostat input DH. If the airflow for cooling is already set to -15% no airflow change will be noticed from normal cooling. Dehumidification mode will be shown on the ABC and the communicating thermostats.

Aurora ‘Advanced’ Control LED Displays

These three LEDs display the status, configuration, and fault codes for the control. These can also be read in plain English via the Aurora AID Tool.

Status LED (LED3, Green)

Description of Operation	Fault LED, Green
Normal Mode	ON
Control is Non-functional	OFF
Test Mode	Slow Flash
Lockout Active	Fast Flash
Dehumidification Mode	Flash Code 2
Load Shed	Flash Code 5
Emergency Shutdown	Flash Code 6
On Peak Mode	Flash Code 7
(Future Use)	Flash Code 8
(Future Use)	Flash Code 9

Configuration LED (LED2, Yellow)

Description of Operation	Configuration LED, Yellow
No Software Overwritten	ECM Setting
DIP Switch Overwritten	Slow Flash
ECM Configuration Mode	Fast Flash
Reset Configuration Mode	OFF

Fault LED (LED1, Red)

Red Fault LED	LED Flash Code *	Lockout	Reset/ Remove	Fault Condition Summary	
Normal - No Faults	Off	-			
ABC Basic Faults	Fault-Input	1	No	Auto	Tstat input error. Autoreset upon condition removal.
	Fault-High Pressure	2	Yes	Hard or Soft	HP switch has tripped (>600 psi)
	Fault-Low Pressure	3	Yes	Hard or Soft	Low Pressure Switch has tripped (<40 psi for 30 continuous sec.)
	Fault-Freeze Detection FP2	4	Yes	Hard or Soft	Freeze protection sensor has tripped (<15 or 30 degF for 30 continuous sec.)
	Fault-Freeze Detection FP1	5	Yes	Hard or Soft	Freeze protection sensor has tripped (<15 or 30 degF for 30 continuous sec.)
	Fault-Condensate Overflow	7	Yes	Hard or Soft	Condensate switch has shown continuity for 30 continuous sec.
	Fault-Over/Under Voltage	8	No	Auto	Instantaneous voltage is out of range. **Controls shut down until resolved.
	Fault-FP1 Snsr Error	11	Yes	Hard or Soft	FP1 Sensor Open or Shorted
ABC & AXB Advanced Faults	Fault-Compressor Monitor	10	Yes	Hard or Soft	Open Crkt, Run, Start or welded cont
	Non-CriticAXBSnsrErr	13	No	Auto	Any Other Sensor Error
	CriticAXBSnsrErr	14	Yes	Hard or Soft	Sensor Error for EEV or HW
	Alert-HotWtr	15	No	Auto	HW over limit or logic lockout. HW pump deactivated.
	Fault-VarSpdPump	16	No	Auto	Alert is read from PWM feedback.
	Non-CritComErr	18	No	Auto	Any non-critical com error
	Fault-CritComErr	19	No	Auto	Any critical com error. Auto reset upon condition removal
	Alarm - Low Loop Pressure	21	No	Auto	Loop pressure is below 3 psi for more than 3 minutes
	Alarm - Home Automation 1	23	No	Auto	Closed contact input is present on Dig 2 input - Text is configurable
	Alarm - Home Automation 2	24	No	Auto	Closed contact input is present on Dig 3 input - Text is configurable

NOTES:

*All codes >11 use long flash for tens digit and short flash for the ones digit. 20, 30, 40, 50 etc. are skipped!

Alert* is a noncritical sensor or function that has failed. Normal operation of the heat pump is maintained but service is desired at some point.

Operation Logic Data Table

Operation Logic Table	Heating					Cooling			
	STG1	STG2	STG3	EMERG	Fan Only	STG1	STG2	Reheat	Fan Only
Compressor	On	On	On	Off	Off	On	On	On	Off
Reversing Valve	Off	Off	Off	Off	Off	On	On	On	On
Aux Heat	Off	Off	Staged	Staged	Off	Off	Off	Off	Off
Acc Relay	On	On	On	Off	Off	On	On	On	Off
Fan Relay (PSC)	On	On	On	On	On	On	On	On	On
Loop Pump	On	On	On	Off	Off	On	On	On	Off
Hot Water	On	On	On	Off	Off	On	On	NA	Off
5-Speed ECM Speed	Med Low	Med High	High	High	Low	Med Low	Med High	High	Low
ECM Speed	Med	High	Aux	Aux	Low	Med	High	High	Low
T-Stat Signal	Y1	Y1,Y2	Y1,Y2,W	W	G	Y1,O	Y1,Y2,O	DH	G

5/11/12

Water Quality

It is the responsibility of the system designer and installing contractor to ensure that acceptable water quality is present and that all applicable codes have been met in these installations. Failure to adhere to the guidelines in the water quality table could result in loss of warranty. In ground water situations where scaling could be heavy or where biological growth such as iron bacteria will be present, a closed loop system is recommended. The heat exchanger coils in ground water systems may, over a period of time, lose heat exchange capabilities due to a buildup of mineral deposits inside. These can be cleaned, but only by a qualified service mechanic, as special solutions and pumping equipment are required. Hot water generator coils can likewise become scaled and possibly plugged. In areas with extremely hard water, the owner should be informed that the heat exchanger may require occasional flushing.

Heat pumps with cupronickel heat exchangers are recommended for open loop applications due to the increased resistance to build-up and corrosion, along with reduced wear caused by acid cleaning.

Water Treatment

Do not use untreated or improperly treated water. Equipment damage may occur. The use of improperly treated or untreated water in this equipment may result in scaling, erosion, corrosion,

algae or slime. Purchase of a pre-mix antifreeze could significantly improve system reliability if the water quality is controlled and there are additives in the mixture to inhibit corrosion. There are many examples of such fluids on the market today such as Environol™ 1000 (pre-mix ethanol), and others. The services of a qualified water treatment specialist should be engaged to determine what treatment, if any, is required. The product warranty specifically excludes liability for corrosion, erosion or deterioration of equipment.

The heat exchangers and water lines in the units are copper or cupronickel tube. There may be other materials in the buildings piping system that the designer may need to take into consideration when deciding the parameters of the water quality. If antifreeze or water treatment solution is to be used, the designer should confirm it does not have a detrimental effect on the materials in the system.

Contaminated Water

In applications where the water quality cannot be held to prescribed limits, the use of a secondary or intermediate heat exchanger is recommended to separate the unit from the contaminated water. The table above outlines the water quality guidelines for unit heat exchangers. If these conditions are exceeded, a secondary heat exchanger is required. Failure to supply a secondary heat exchanger where needed will result in a warranty exclusion for primary heat exchanger corrosion or failure.

Material		Copper	90/10 Cupronickel	316 Stainless Steel
pH	Acidity/Alkalinity	7 - 9	7 - 9	7 - 9
Scaling	Calcium and Magnesium Carbonate	(Total Hardness) less than 350 ppm	(Total Hardness) less than 350 ppm	(Total Hardness) less than 350 ppm
Corrosion	Hydrogen Sulfide	Less than 0.5 ppm (rotten egg smell appears at 0.5 ppm)	10 - 50 ppm	Less than 1 ppm
	Sulfates	Less than 125 ppm	Less than 125 ppm	Less than 200 ppm
	Chlorine	Less than 0.5 ppm	Less than 0.5 ppm	Less than 0.5 ppm
	Chlorides	Less than 20 ppm	Less than 125 ppm	Less than 300 ppm
	Carbon Dioxide	Less than 50 ppm	10 - 50 ppm	10 - 50 ppm
	Ammonia	Less than 2 ppm	Less than 2 ppm	Less than 20 ppm
	Ammonia Chloride	Less than 0.5 ppm	Less than 0.5 ppm	Less than 0.5 ppm
	Ammonia Nitrate	Less than 0.5 ppm	Less than 0.5 ppm	Less than 0.5 ppm
	Ammonia Hydroxide	Less than 0.5 ppm	Less than 0.5 ppm	Less than 0.5 ppm
	Ammonia Sulfate	Less than 0.5 ppm	Less than 0.5 ppm	Less than 0.5 ppm
Iron Fouling (Biological Growth)	Total Dissolved Solids (TDS)	Less than 1000 ppm	1000 - 1500 ppm	1000 - 1500 ppm
	LSI Index	+0.5 to -0.5	+0.5 to -0.5	+0.5 to -0.5
Iron Fouling (Biological Growth)	Iron, FE ²⁺ (Ferrous) Bacterial Iron Potential	< 0.2 ppm	< 0.2 ppm	< 0.2 ppm
	Iron Oxide	Less than 1 ppm, above this level deposition will occur	Less than 1 ppm, above this level deposition will occur	Less than 1 ppm, above this level deposition will occur
Erosion	Suspended Solids	Less than 10 ppm and filtered for max. of 600 micron size	Less than 10 ppm and filtered for max. of 600 micron size	Less than 10 ppm and filtered for max. of 600 micron size
	Threshold Velocity (Fresh Water)	< 6 ft/sec	< 6 ft/sec	< 6 ft/sec

NOTES: Grains = ppm divided by 17 mg/L is equivalent to ppm

2/22/12

Vertical Dimensional Data

Top Air Discharge

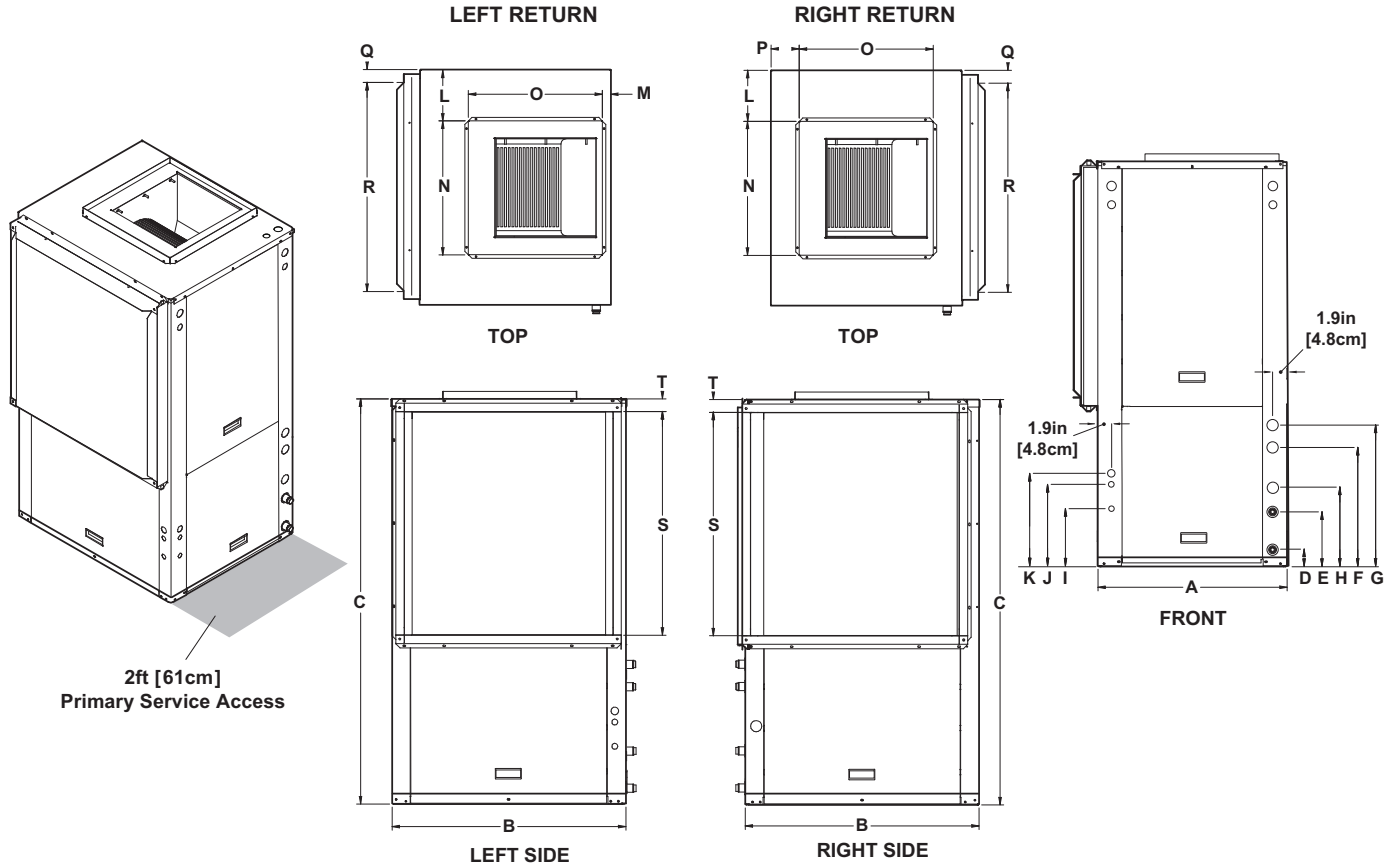

Vertical Top Flow Model	Overall Cabinet			Water Connections								Electrical Connections			Discharge Connection duct flange installed (±0.10 in)					Return Connection using std deluxe filter rack (±0.10 in)			
	A	B	C	D	E	F	G	H	Loop	HWG	I	J	K	L	M	N	O	P	Q	R	S	T	
	Width	Depth	Height	Loop In	Loop Out	HWG In	HWG Out	Condensate	Water FPT	Sweat (I.D.)	3/4 in. cond	1/2 in. cond	1/2 in. cond			Supply Width	Supply Depth		Return Depth	Return Height			
											Power Supply	Ext Pump	Low Voltage										
012	in.	22.2	22.5	34.5	2.3	5.3	11.9	14.9	8.6	1 in.	1/2 in.	6.9	9.4	11.7	6.1	3.7	10.0	10.0	0.7	2.4	18.1	14.2	1.7
	cm.	56.4	57.2	87.6	5.9	13.5	30.2	37.8	21.8	Swivel	Female	17.5	23.9	29.7	15.5	9.4	25.4	25.4	1.8	6.1	46.0	36.1	4.3
018	in.	22.5	26.5	39.4	2.3	5.3	13.4	16.4	9.6	1 in.	1/2 in.	6.9	9.4	11.7	6.3	0.7	14.0	14.0	2.7	2.3	22.0	18.0	2.0
	cm.	57.2	67.3	100.1	5.8	13.5	34.0	41.7	24.4	Swivel	Female	17.5	23.9	29.7	16.0	1.8	35.6	35.6	6.9	5.8	55.9	45.7	5.1
022-030	in.	22.5	26.5	48.5	2.0	7.0	13.5	16.5	10.2	1 in.	1/2 in.	9.5	12.1	14.3	6.1	0.8	14.0	14.0	4.4	1.7	22.2	26.0	1.7
	cm.	57.2	67.3	123.2	5.1	17.8	34.3	41.9	25.9	Swivel	Female	24.1	30.7	36.3	15.5	2.0	35.6	35.6	11.2	4.3	56.4	66.0	4.3
036-038	in.	25.6	31.6	50.4	2.3	7.3	15.9	18.9	10.6	1 in.	1/2 in.	9.5	12.1	14.3	6.9	1.1	18.0	18.0	3.8	1.7	28.1	26.0	1.7
	cm.	65.0	80.3	128.0	5.8	18.5	40.4	48.0	26.9	Swivel	Female	24.1	30.7	36.3	17.5	2.8	45.7	45.7	9.7	4.3	71.4	66.0	4.3
042-049	in.	25.6	31.6	54.4	2.3	7.3	15.9	18.9	10.6	1 in.	1/2 in.	9.5	12.1	14.3	6.9	1.1	18.0	18.0	3.8	1.7	28.1	30.0	1.7
	cm.	65.0	80.3	138.2	5.8	18.5	40.4	48.0	26.9	Swivel	Female	24.1	30.7	36.3	17.5	2.8	45.7	45.7	9.7	4.3	71.4	76.2	4.3
060-072	in.	25.6	31.6	58.4	2.3	7.3	15.9	18.9	10.6	1 in.	1/2 in.	9.5	12.1	14.3	6.9	1.1	18.0	18.0	3.8	1.7	28.1	34.0	1.7
	cm.	65.0	80.3	148.3	5.8	18.5	40.4	48.0	26.9	Swivel	Female	24.1	30.7	36.3	17.5	2.8	45.7	45.7	9.7	4.3	71.4	86.4	4.3

Condensate is 3/4 in. PVC female glue socket and is switchable from side to front
 Unit shipped with deluxe 2 in. (field adjustable to 1 in.) duct collar/filter rack extending from unit 3.25 in. and is suitable for duct connection.
 Discharge flange is field installed and extends 1 in. [25.4 mm] from cabinet
 Decorative molding and/or water connections extend 1.2 in. [30.5 mm] beyond front of cabinet.
 Top auxiliary electric heat power knockouts are 1.125" and 1.375".

7/11/12

Vertical Dimensional Data cont.

Bottom Air Discharge

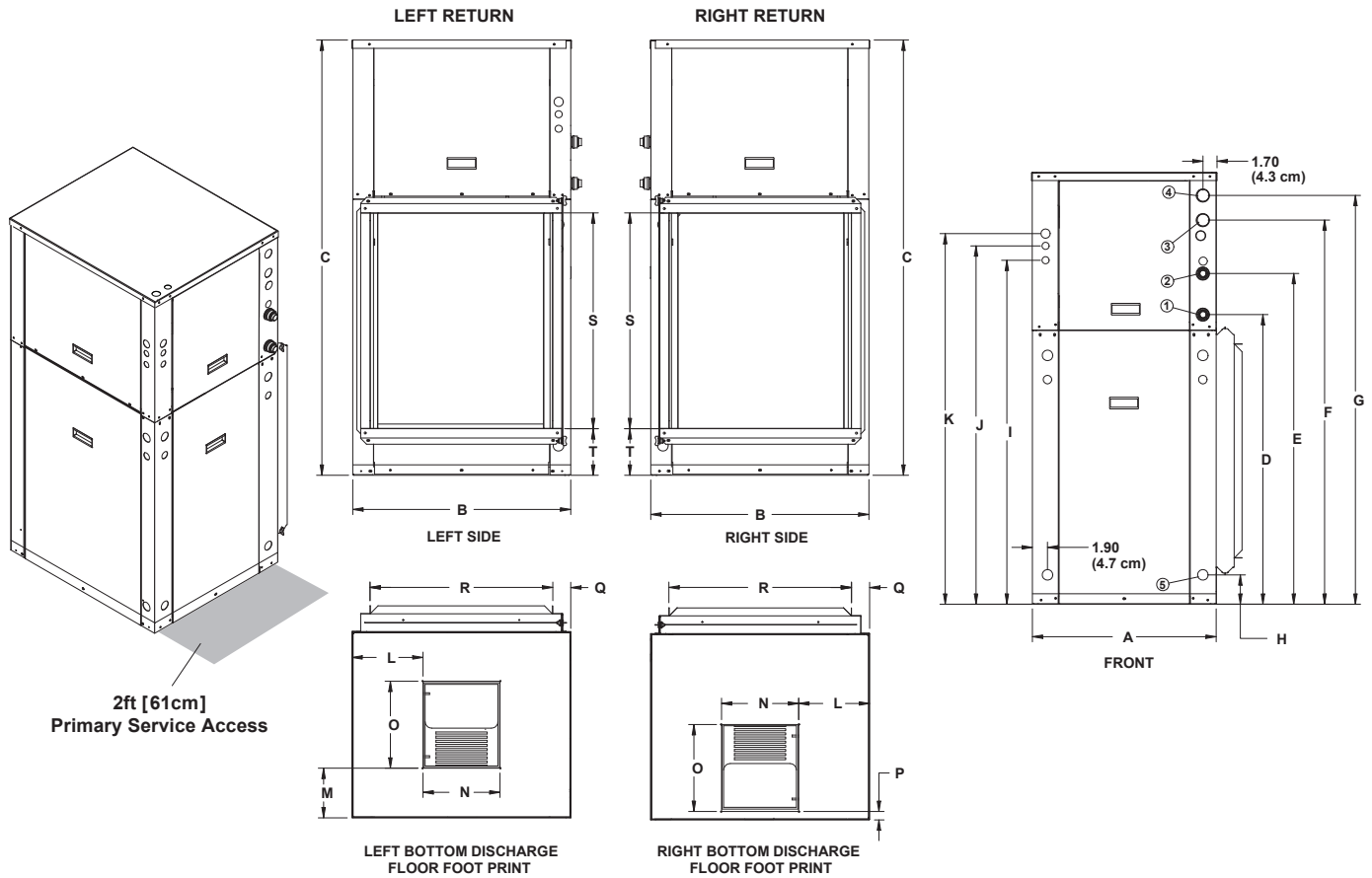

Bottom Flow Models	Overall Cabinet			Water Connections							Electrical Knockouts			Discharge Connection duct flange installed (±0.10 in)					Return Connection using std deluxe filter rack (±0.10 in)				
				1	2	3	4	5			I 3/4 in. cond	J 1/2 in. cond	K 1/2 in. cond										
	A	B	C	D	E	F	G	H	Loop Water FPT	HWG Sweat (I.D.)	Power Supply	Ext Pump	Low Voltage	L	M	N Supply Width	O Supply Depth	P	Q	R Return Depth	S Return Height	T	
022-	in.	22.5	26.5	52.5	35.3	40.2	46.7	49.7	3.6	1 in.	1/2 in.	41.9	43.6	45.1	8.6	6.0	9.3	10.5	1.0	2.2	22.2	26.0	5.6
030	cm.	57.2	67.3	133.4	89.7	102.1	118.6	126.2	9.1	Swivel	Female	106.4	110.7	114.6	21.8	15.2	23.6	26.7	2.5	5.6	56.4	66.0	14.2
036-	in.	25.5	31.5	62.5	43.4	48.4	57.0	60.0	3.6	1 in.	1/2 in.	48.9	50.8	52.2	9.1	4.8	13.4	13.6	1.5	1.8	28.1	34.0	5.6
072	cm.	64.8	80.0	158.8	110.2	122.9	144.8	152.4	9.1	Swivel	Female	124.2	129.0	132.6	23.1	12.2	34.0	34.5	3.8	4.6	71.4	86.4	14.2

Condensate is 3/4 in. PVC female glue socket and is switchable from side to front

Vertical bottom flow unit shipped with deluxe 2 in. (field adjustable to 1 in.) duct collar/filter rack extending from unit 3.25 in. and is suitable for duct connection.

Decorative molding and/or water connections extend 1.2 in. (30.5mm) beyond front of cabinet.

Top auxiliary electric heat power knockouts are 1.125" and 1.375".

7/11/12

Vertical Dimensional Data cont.

Rear Air Discharge

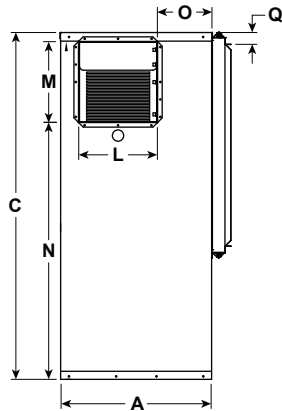
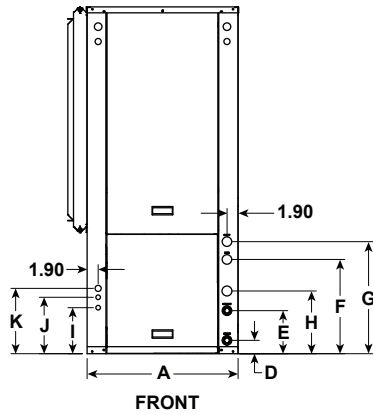
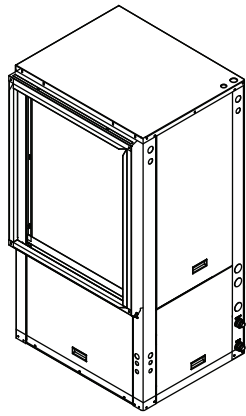

REAR VIEW
LEFT RETURN

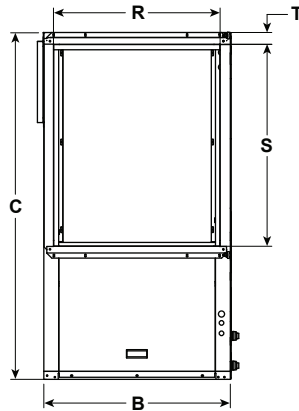

SIDE VIEW
LEFT RETURN

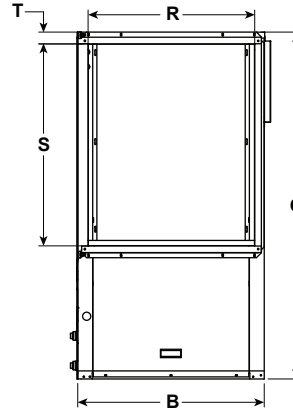

SIDE VIEW
RIGHT RETURN

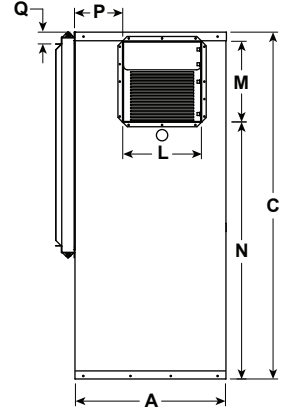

REAR VIEW
RIGHT RETURN

Vertical Rear Discharge Models	Overall Cabinet			Water Connections								Electrical Connections			Discharge Connection duct flange installed (±0.10 in)					Return Connection using std deluxe filter rack (±0.10 in)			
	A	B	C	D	E	F	G	H	Loop Water FPT	HWG Sweat (I.D.)	I	J	K	L	M	N	O	P	Q	R	S	T	
	Width	Depth	Height	Loop In	Loop Out	HWG In	HWG Out	Condensate			3/4 in. cond	1/2 in. cond	1/2 in. cond	Supply Width	Supply Depth						Return Depth	Return Height	
												Power Supply	Ext Pump	Low Voltage									
042-	in.	25.6	31.6	54.4	2.3	7.3	15.9	18.9	10.6	1"	1/2"	9.5	12.1	14.3	13.3	13.6	39.4	9.1	8.1	1.7	28.1	30.0	1.7
049	cm.	65.0	80.3	138.2	5.8	18.5	40.4	48.0	26.9	Swivel	female	24.1	30.7	36.3	33.8	34.5	100.1	23.1	20.6	4.3	71.4	76.2	4.3
060-	in.	25.6	31.6	58.4	2.3	7.3	15.9	18.9	10.6	1"	1/2"	9.5	12.1	14.3	13.3	13.6	43.4	9.1	8.1	1.7	28.1	34.0	1.7
072	cm.	65.0	80.3	148.3	5.8	18.5	40.4	48.0	26.9	Swivel	female	24.1	30.7	36.3	33.8	34.5	110.2	23.1	20.6	4.3	71.4	86.4	4.3

Condensate is 3/4 in. PVC female glue socket and is switchable from side to front
 Unit shipped with deluxe 2 in. (field adjustable to 1 in.) duct collar/filter rack extending from unit 3.25 in. and is suitable for duct connection.
 Discharge flange is field installed and extends 1 in. [25.4mm] from cabinet
 Decorative molding and/or water connections extend 1.2 in. [30.5mm] beyond front of cabinet.
 Top auxiliary electric heat power knockouts are 1.125" and 1.375".

7/11/12

Horizontal Dimensional Data

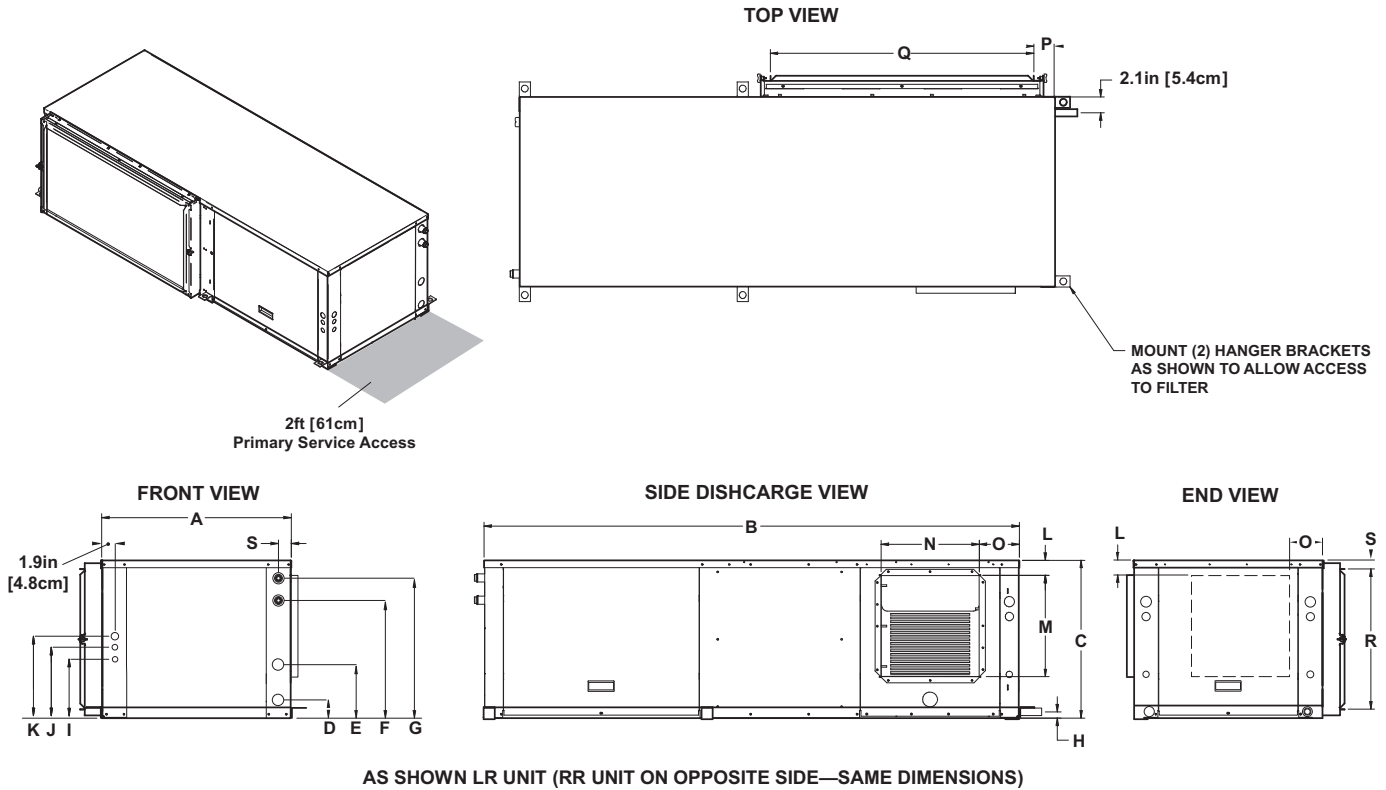

Horizontal Model	Overall Cabinet			Water Connections								Electrical Connections			Discharge Connection duct flange installed (±0.10 in)				Return Connection using std deluxe filter rack (±0.10 in)			
	A	B	C	D	E	F	G	H	Loop Water FPT	HWG Sweat (I.D.)	I 3/4 in. cond Power Supply	J 1/2 in. cond Ext Pump	K 1/2 in. cond Low Voltage	L	M	N	O	P	Q	R	S	
	Width	Depth	Height	In	Out	HWG In	HWG Out	Cond-ensate							Supply Height	Supply Depth			Return Depth	Return Height		
012	in.	22.5	44.0	17.3	2.3	5.3	11.9	14.9	8.0	1 in.	1/2 in.	6.9	9.5	11.7	4.1	7.3	9.7	5.8	1.7	17.8	14.6	1.4
	cm.	57.2	111.8	43.9	5.8	13.5	30.2	37.8	20.3	Swivel	Female	17.5	24.1	29.7	10.4	18.5	24.6	14.7	4.3	45.2	37.1	3.6
018	in.	22.5	53.0	19.3	2.3	5.3	13.8	16.8	8.0	1 in.	1/2 in.	6.9	9.5	11.7	1.8	10.5	9.5	8.2	2.2	21.8	16.5	1.5
	cm.	57.2	134.6	49.0	5.8	13.5	35.1	42.7	20.3	Swivel	Female	17.5	24.1	29.7	4.6	26.7	24.1	20.8	5.6	55.4	41.9	3.8
022-030	in.	22.5	63.0	19.3	2.0	7.0	13.5	16.5	0.8	1 in.	1/2 in.	9.5	12.1	14.3	2.3	10.5	9.4	5.8	2.8	30.5	16.9	1.3
	cm.	57.2	160.0	49.0	5.1	17.8	34.3	41.9	2.0	Swivel	Female	24.1	30.7	36.3	5.8	26.7	23.9	14.7	7.1	77.5	42.9	3.3
036-038	in.	25.6	72.0	21.3	2.3	7.3	15.9	18.9	0.8	1 in.	1/2 in.	9.5	12.1	14.3	SEE	13.6	13.2	SEE	2.8	35.5	18.9	1.3
	cm.	65.0	182.9	54.1	5.8	18.5	40.4	48.0	2.0	Swivel	Female	24.1	30.7	36.3	CHART	34.5	33.5	CHART	7.1	90.2	48.0	3.3
042-049	in.	25.6	77.0	21.3	2.3	7.3	15.9	18.9	0.8	1 in.	1/2 in.	9.5	12.1	14.3	SEE	13.6	13.2	SEE	2.8	40.4	18.9	1.3
	cm.	65.0	195.6	54.1	5.8	18.5	40.4	48.0	2.0	Swivel	Female	24.1	30.7	36.3	CHART	34.5	33.5	CHART	7.1	102.6	48.0	3.3
060-072	in.	25.6	82.0	21.3	2.3	7.3	15.9	18.9	0.8	1 in.	1/2 in.	9.5	12.1	14.3	SEE	13.6	13.2	SEE	2.8	45.4	18.9	1.3
	cm.	65.0	208.3	54.1	5.8	18.5	40.4	48.0	2.0	Swivel	Female	24.1	30.7	36.3	CHART	34.5	33.5	CHART	7.1	115.3	48.0	3.3

Condensate is 3/4 in. PVC female glue socket and is switchable from side to front
 Unit shipped with deluxe 2 in. (field adjustable to 1 in.) duct collar/filter rack extending from unit 3.25 in. and is suitable for duct connection.
 Discharge flange is field installed and extends 1 in. [25.4mm] from cabinet
 Decorative molding and/or water connections extend 1.2 in. [30.5mm] beyond front of cabinet.

7/11/12

Units Not Shown Above		L	O
Right Return End Discharge	in	2.8	4.6
	cm	7.1	11.8
Right Return Side Discharge	in	4.9	6.9
	cm	12.4	17.5
Left Return End Discharge	in	4.9	7.6
	cm	12.4	19.4
Left Return Side Discharge	in	2.8	6.9
	cm	7.1	17.5

Physical Data

Single Speed

Model		SINGLE SPEED								
		012	018	022	030	036	042	048	060	070
Compressor (1 each)		Rotary			Scroll					
Factory Charge R410a, oz [kg] (Aluminum tube and fin air coil)	Vertical	36 [1.02]	42 [1.19]	56 [1.58]	64 [1.81]	80 [2.26]	82 [2.32]	84 [2.38]	88 [2.49]	134 [3.79]
Factory Charge R410a, oz [kg] (Aluminum tube and fin air coil)	Horizontal	36 [1.02]	42 [1.19]	54 [1.53]	64 [1.81]	74 [2.10]	80 [2.27]	86 [2.44]	78 [2.21]	110 [3.11]
Blower Motor & Blower										
Blower Motor Type/Speeds	VS ECM	n/a	Variable Speed ECM							
	5-Spd ECM	n/a	n/a	5 Speed ECM						
	PSC	PSC - 4 Speeds	n/a							
Blower Motor- hp [W]	VS ECM	n/a	1/2 [373]	1/2 [373]	1/2 [373]	1/2 [373]	1/2 [373]	1/2 [373]	1 [746]	1 [746]
	5-Spd ECM	n/a	n/a	1/2 [373]	1/2 [373]	1/2 [373]	1 [746]	1 [746]	1 [746]	1 [746]
	PSC	1/10 [75]	n/a	n/a	n/a	n/a	n/a	n/a	n/a	n/a
Blower Wheel Size (Dia x W), in. [mm]	VS ECM & 5-Spd ECM	n/a	9 x 7 [229 x 178]	9 x 7 [229 x 178]	9 x 7 [229 x 178]	11 x 10 [279 x 254]	11 x 10 [279 x 254]	11 x 10 [279 x 254]	11 x 10 [279 x 254]	11 x 10 [279 x 254]
	PSC	6 x 8 [152 x 203]	n/a	n/a	n/a	n/a	n/a	n/a	n/a	n/a
Coax and Water Piping										
Water Connections Size - Swivel - in [mm]		1" [25.4]	1" [25.4]	1" [25.4]	1" [25.4]	1" [25.4]	1" [25.4]	1" [25.4]	1" [25.4]	1" [25.4]
HWG Connection Size - Female Sweat I.D. - in [mm]		n/a	1/2" [12.7]	1/2" [12.7]	1/2" [12.7]	1/2" [12.7]	1/2" [12.7]	1/2" [12.7]	1/2" [12.7]	1/2" [12.7]
Coax & Piping Water Volume - gal [l]		0.35 [1.3]	0.40 [1.5]	0.7 [2.6]	1.0 [3.8]	1.3 [4.9]	1.3 [4.9]	1.6 [6.1]	1.6 [6.1]	2.3 [8.7]
Vertical										
Air Coil Dimensions (H x W), in. [mm]		16 x 16 [406 x 406]	19 x 20 [483 x 508]	24 x 20 [610 x 542]	28 x 20 [711 x 542]	28 x 25 [711 x 635]	32 x 25 [813 x 635]	32 x 25 [813 x 635]	36 x 25 [914 x 635]	36 x 25 [914 x 635]
Air Coil Total Face Area, ft2 [m2]		1.8 [0.167]	2.6 [0.242]	3.3 [0.310]	3.9 [0.362]	4.9 [0.451]	5.6 [0.570]	5.6 [0.570]	6.3 [0.641]	6.3 [0.641]
Air Coil Tube Size, in [mm]		3/8 [9.5]	5/16 [7.9]	3/8 [9.5]	3/8 [9.5]	3/8 [9.5]	3/8 [9.5]	3/8 [9.5]	3/8 [9.5]	3/8 [9.5]
Air Coil Number of rows		3	3	3	3	3	3	3	4	4
Filter Standard - 2" [51mm] Pleated MERV11 Throwaway, in [mm]		16 x 20 [406 x 508]	20 x 24 [508 x 610]	28 x 24 [712 x 610]	28 x 24 [712 x 610]	28 x 30 [712 x 762]	32 x 30 [813 x 762]	32 x 30 [813 x 762]	36 x 30 [914 x 762]	36 x 30 [914 x 762]
Weight - Operating, lb [kg]		165 [75]	200 [91]	293 [133]	308 [140]	353 [160]	368 [167]	408 [185]	443 [201]	468 [212]
Weight - Packaged, lb [kg]		185 [84]	220 [100]	313 [142]	328 [149]	373 [169]	388 [176]	428 [194]	463 [210]	488 [221]
Horizontal										
Air Coil Dimensions (H x W), in. [mm]		16 x 16 [406 x 406]	18 x 21 [457 x 533]	18 x 27 [457 x 686]	18 x 30 [457 x 762]	20 x 35 [508 x 889]	20 x 40 [508 x 1016]	20 x 40 [508 x 1016]	20 x 45 [508 x 1143]	20 x 45 [508 x 1143]
Air Coil Total Face Area, ft2 [m2]		1.8 [0.167]	2.6 [0.242]	3.4 [0.316]	3.9 [0.362]	4.9 [0.451]	5.6 [0.570]	5.6 [0.570]	6.3 [0.641]	6.3 [0.641]
Air Coil Tube Size, in [mm]		3/8 [9.5]	5/16 [7.9]	3/8 [9.5]	3/8 [9.5]	3/8 [9.5]	3/8 [9.5]	3/8 [9.5]	3/8 [9.5]	3/8 [9.5]
Air Coil Number of rows		3	3	3	3	3	3	3	3	3
Filter Standard - 2" [51mm] Pleated MERV11 Throwaway, in [mm]		1 - 16 x 20 [406 x 508]	1 - 18 x 24 [457 x 610]	1 - 18 x 32 [457 x 813]	1 - 18 x 32 [457 x 813]	1 - 20 x 37 [686 x 940]	1 - 20 x 20 [508 x 508] 1 - 20 x 22 [508 x 559]	1 - 20 x 20 [508 x 508] 1 - 20 x 22 [508 x 559]	1 - 20 x 25 [508 x 635] 1 - 20 x 22 [508 x 559]	1 - 20 x 25 [508 x 635] 1 - 20 x 22 [508 x 559]
Weight - Operating, lb [kg]		165 [75]	200 [91]	300 [136]	315 [143]	368 [167]	403 [183]	418 [190]	453 [205]	478 [217]
Weight - Packaged, lb [kg]		185 [84]	220 [100]	320 [145]	335 [152]	388 [176]	423 [192]	438 [199]	473 [215]	498 [226]

7/15/22

Physical Data cont.

Dual Capacity

Model			DUAL CAPACITY				
			026	038	049	064	072
Compressor (1 each)			Copeland UltraTech, Dual Capacity Scroll				
Factory Charge R410a, oz [kg]	(Aluminum tube and fin air coil)	Vertical	56 [1.58]	76 [2.15]	84 [2.38]	86 [2.44]	130 [3.68]
Factory Charge R410a, oz [kg]	(Aluminum tube and fin air coil)	Horizontal	58 [1.64]	70 [1.98]	82 [2.32]	100 [2.83]	136 [3.85]
ECM Blower Motor & Blower							
Blower Motor Type/Speeds	VS ECM	Variable Speed ECM					
	5-Spd ECM	5 Speed ECM					
Blower Motor- hp [W]	VS ECM	1/2 [373]	1/2 [373]	1/2 [373]	1 [746]	1 [746]	
	5-Spd ECM	1/2 [373]	1/2 [373]	1 [746]	1 [746]	1 [746]	
Blower Wheel Size (Dia x W), in. [mm]	VS ECM	9 x 7 [229 x 178]	11 x 10 [279 x 254]	11 x 10 [279 x 254]	11 x 10 [279 x 254]	11 x 10 [279 x 254]	
	5-Spd ECM	9 x 7 [229 x 178]	11 x 10 [279 x 254]	11 x 10 [279 x 254]	11 x 10 [279 x 254]	11 x 10 [279 x 254]	
Coax and Water Piping							
Water Connections Size - Swivel - in [mm]			1" [25.4]	1" [25.4]	1" [25.4]	1" [25.4]	1" [25.4]
HWG Connection Size - Female Sweat I.D. - in [mm]			1/2" [12.7]	1/2" [12.7]	1/2" [12.7]	1/2" [12.7]	1/2" [12.7]
Coax & Piping Water Volume - gal [l]			0.7 [2.6]	1.3 [4.9]	1.6 [6.1]	1.6 [6.1]	2.3 [8.7]
Vertical							
Air Coil Dimensions (H x W), in. [mm]			24 x 20 [610 x 542]	28 x 25 [711 x 635]	32 x 25 [813 x 635]	36 x 25 [914 x 635]	36 x 25 [914 x 635]
Air Coil Total Face Area, ft2 [m2]			3.3 [0.310]	4.9 [0.451]	5.6 [0.570]	6.3 [0.641]	6.3 [0.641]
Air Coil Tube Size, in [mm]			3/8 [9.5]	3/8 [9.5]	3/8 [9.5]	3/8 [9.5]	3/8 [9.5]
Air Coil Number of rows			3	3	3	4	4
Filter Standard - 2" [51mm] Pleated MERV11 Throwaway, in [mm]			28 x 24 [712 x 610]	28 x 30 [712 x 762]	32 x 30 [813 x 762]	36 x 30 [914 x 762]	36 x 30 [914 x 762]
Weight - Operating, lb [kg]			293 [133]	358 [162]	408 [185]	453 [205]	468 [212]
Weight - Packaged, lb [kg]			313 [142]	378 [172]	428 [194]	473 [215]	488 [221]
Horizontal							
Air Coil Dimensions (H x W), in. [mm]			18 x 27 [457 x 686]	20 x 35 [508 x 889]	20 x 40 [508 x 1016]	20 x 45 [508 x 1143]	20 x 45 [508 x 1143]
Air Coil Total Face Area, ft2 [m2]			3.4 [0.316]	4.9 [0.451]	5.6 [0.570]	6.3 [0.641]	6.3 [0.641]
Air Coil Tube Size, in [mm]			3/8 [9.5]	3/8 [9.5]	3/8 [9.5]	3/8 [9.5]	3/8 [9.5]
Air Coil Number of rows			3	3	3	4	4
Filter Standard - 2" [51mm] Pleated MERV11 Throwaway, in [mm]			1 - 18 x 32 [457 x 813]	1 - 20 x 37 [686 x 940]	1 - 20 x 20 [508 x 508] 1 - 20 x 22 [508 x 559]	1 - 20 x 25 [508 x 635] 1 - 20 x 22 [508 x 559]	1 - 20 x 25 [508 x 635] 1 - 20 x 22 [508 x 559]
Weight - Operating, lb [kg]			300 [136]	368 [167]	418 [190]	463 [210]	480 [218]
Weight - Packaged, lb [kg]			320 [145]	388 [176]	438 [199]	483 [219]	500 [227]

7/15/22

Auxiliary Heat Ratings

Model	kW		Stages	Btu/h		Min cfm	Model Size Compatibility						
	208V	230V		208V	230V		012	018	022	026 - 030	036 - 042	048 - 072	
EAS(H)4A	2.9	3.8	1	9,700	12,900	250	•						
EAM(H)5A	3.6	4.8	1	12,300	16,300	450		•	•	•			
EAM(H)8A	5.7	7.6	2	19,400	25,900	550		•	•	•			
EAM(H)10A	7.2	9.6	2	24,600	32,700	650				•			
EAL(H)10A	7.2	9.6	2	24,600	32,700	1100					•	•	
EAL(H)15A	10.8	14.4	2	36,900	49,100	1250					•	•	
EAL(H)20A	14.4	19.2	2	49,200	65,500	1500							•

Order the "H" part number when installed on horizontal and vertical rear discharge units
 Air flow level for auxiliary heat (Aux) must be above the minimum cfm in this table

2/24/22

Auxiliary Heat Electrical Data

Model	Supply Circuit	Heater Amps		Min Circuit Amp		Fuse (USA)		Fuse (CAN)		CKT BRK	
		208 V	240 V	208 V	240 V	208 V	240 V	208 V	240 V	208 V	240 V
EAS(H)4A	Single	13.7	15.8	17.9	20.5	20	20	20	20	20	20
EAM(H)5A	Single	17.3	20.0	26.7	30.0	30	30	30	30	30	30
EAM(H)8A	Single	27.5	31.7	39.3	44.6	40	45	40	45	40	45
EAM(H)10A	Single	34.7	40.0	48.3	55.0	50	60	50	60	50	60
EAL(H)10A	Single	34.7	40.0	53.3	60.0	60	60	60	60	60	60
EAL(H)15A	Single	52.0	60.0	75.0	85.0	80	90	80	90	70	100
	L1/L2	34.7	40.0	53.3	60.0	60	60	60	60	60	60
	L3/L4	17.3	20.0	21.7	25.0	25	25	25	25	20	30
EAL(H)20A	Single	69.3	80.0	96.7	110.0	100	110	100	110	100	100
	L1/L2	34.7	40.0	53.3	60.0	60	60	60	60	60	60
	L3/L4	34.7	40.0	43.3	50.0	45	50	45	50	40	50

All heaters rated single phase 60 cycle and include unit blower load
 All fuses type "D" time delay (or HACR circuit breaker in USA)
 Supply wire size to be determined by local codes

6/11/15

Electrical Data

Single Speed Unit with Variable Speed ECM Motor

Model	Rated Voltage	Voltage Min/Max	Compressor				HWG Pump FLA	Ext Loop FLA	Blower Motor FLA	Total Unit FLA	Min Circ Amp	Max Fuse/HACR
			MCC	RLA	LRA	LRA**						
018	208-230/60/1	187/253	10.4	6.7	33.5	N/A	0.4	5.4	4.0	16.5	18.1	20
022	208-230/60/1	187/253	14.0	9.0	48.0	17.0	0.4	5.4	4.0	18.8	21.0	30
030	208-230/60/1	187/253	20.0	12.8	58.3	21.0	0.4	5.4	4.0	22.6	25.8	35
036	208-230/60/1	187/253	22.0	14.1	73.0	26.0	0.4	5.4	4.0	23.9	27.4	40
042	208-230/60/1	187/253	26.0	16.6	79.0	28.0	0.4	5.4	4.0	26.4	30.6	45
048	208-230/60/1	187/253	31.0	19.8	109.0	38.0	0.4	5.4	4.0	29.6	34.6	50
060	208-230/60/1	187/253	41.2	26.4	134.0	47.0	0.4	5.4	7.0	39.2	45.8	70
070	208-230/60/1	187/253	44.2	28.3	178.0	63.0	0.4	5.4	7.0	41.1	48.2	70

7/15/22

** With optional IntelliStart®
 Rated voltage of 208/230/60/1
 All fuses Class RK-5
 HACR circuit breaker in USA only

Single Speed Unit with 5-Speed ECM Motor

Model	Rated Voltage	Voltage Min/Max	Compressor				HWG Pump FLA	Ext Loop FLA	Blower Motor FLA	Total Unit FLA	Min Circ Amp	Max Fuse/HACR
			MCC	RLA	LRA	LRA**						
022	208-230/60/1	187/253	14.0	9.0	48.0	17.0	0.4	5.4	4.1	18.9	21.1	30
030	208-230/60/1	187/253	20.0	12.8	58.3	21.0	0.4	5.4	4.1	22.7	25.9	35
036	208-230/60/1	187/253	22.0	14.1	73.0	26.0	0.4	5.4	4.1	24.0	27.5	40
042	208-230/60/1	187/253	26.0	16.6	79.0	28.0	0.4	5.4	7.6	30.0	34.2	50
048	208-230/60/1	187/253	31.0	19.8	109.0	38.0	0.4	5.4	7.6	33.2	38.2	50
060	208-230/60/1	187/253	41.2	26.4	134.0	47.0	0.4	5.4	7.6	39.8	46.4	70
070	208-230/60/1	187/253	44.2	28.3	178.0	63.0	0.4	5.4	7.6	41.7	48.8	70

7/15/13

** With optional IntelliStart®
 Rated voltage of 208/230/60/1
 All fuses Class RK-5
 HACR circuit breaker in USA only

Single Speed Unit with PSC Motor

Model	Rated Voltage	Voltage Min/Max	Compressor				HWG Pump FLA	Ext Loop FLA	Blower Motor FLA	Total Unit FLA	Min Circ Amp	Max Fuse/HACR
			MCC	RLA	LRA	LRA**						
012	208-230/60/1	187/253	7.7	4.9	25.0	N/A	-	5.4	0.6	10.9	12.2	15

07/15/22

** With optional IntelliStart®
 Rated voltage of 208/230/60/1
 All fuses Class RK-5
 HACR circuit breaker in USA only

Electrical Data cont.

Dual Capacity Unit with Variable Speed ECM Motor

Model	Rated Voltage	Voltage Min/Max	Compressor				HWG Pump FLA	Ext Loop FLA	Blower Motor FLA	Total Unit FLA	Min Circ Amp	Max Fuse/HACR
			MCC	RLA	LRA	LRA**						
026	208-230/60/1	187/253	18.2	11.6	58.3	21.0	0.4	5.4	4.0	21.4	24.4	35
038	208-230/60/1	187/253	23.8	15.2	83.0	30.0	0.4	5.4	4.0	25.0	28.8	40
049	208-230/60/1	187/253	33.0	21.1	104.0	37.0	0.4	5.4	4.0	30.9	36.2	50
064	208-230/60/1	187/253	42.3	27.1	152.9	54.0	0.4	5.4	7.0	39.9	46.6	70
072	208-230/60/1	187/253	46.3	29.6	179.2	63.0	0.4	5.4	7.0	42.4	49.8	70

07/15/22

** With optional IntelliStart®
 Rated voltage of 208/230/60/1
 All fuses Class RK-5
 HACR circuit breaker in USA only

Dual Capacity Unit with 5-Speed ECM Motor

Model	Rated Voltage	Voltage Min/Max	Compressor				HWG Pump FLA	Ext Loop FLA	Blower Motor FLA	Total Unit FLA	Min Circ Amp	Max Fuse/HACR
			MCC	RLA	LRA	LRA**						
026	208-230/60/1	187/253	18.2	11.6	58.3	21.0	0.4	5.4	4.1	21.5	24.5	35
038	208-230/60/1	187/253	23.8	15.2	83.0	30.0	0.4	5.4	4.1	25.1	28.9	40
049	208-230/60/1	187/253	33.0	21.1	104.0	37.0	0.4	5.4	7.6	34.5	39.8	60
064	208-230/60/1	187/253	42.3	27.1	152.9	54.0	0.4	5.4	7.6	40.5	47.2	70
072	208-230/60/1	187/253	46.3	29.6	179.2	63.0	0.4	5.4	7.6	43.0	50.4	80

9/1/15

** With optional IntelliStart®
 Rated voltage of 208/230/60/1
 All fuses Class RK-5
 HACR circuit breaker in USA only

Blower Performance Data

Single Speed Unit with Variable Speed ECM Motor

Model	Max ESP	Airflow Speed Settings											
		1	2	3	4	5	6	7	8	9	10	11	12
018	0.50	300	400 G	500	600 L	700 H	800	875	950	1025	1125 Aux		
022	0.50		400	500 G	600 L	700	800 H	900	1000	1100	1200 Aux		
030	0.50		400	500 G	600	700 L	800	900 H	1000	1100	1200 Aux		
036	0.50	650	750	850 G	1000	1100 L	1200	1300 H	1400	1500	1550 Aux		
042	0.50	650	800	900 G	1050	1150 L	1250	1350 H	1450	1550	1600 Aux		
048	0.50	650	800	900	1050 G	1150	1250	1350 L	1450	1550 H	1600 Aux		
060	0.75	800	950	1100 G	1300	1500 L	1750	1950 H	2100	2300	2325 Aux		
070	0.75	800	950	1100 G	1300	1500 L	1750	1950 H	2100	2300	2325 Aux		

Factory settings are at recommended G-L-H-Aux speed settings

7/15/22

L-H settings MUST be located within boldface cfm range

"Aux" is factory setting for auxiliary heat and must be equal to or above the "H" setting as well as at least the minimum required for the auxiliary heat package

"G" may be located anywhere within the airflow table

Cfm is controlled within ±5% up to the maximum ESP

Max ESP includes allowance for wet coil and standard filter

Dual Capacity Unit with Variable Speed ECM Motor

Model	Max ESP	Airflow Switch Settings											
		1	2	3	4	5	6	7	8	9	10	11	12
026	0.50		400	500 G	600	700 L	800	900 H	1000	1100	1200 Aux		
038	0.50	650	750 G	850	1000	1100 L	1200	1300 H	1400	1500	1550 Aux		
049	0.50	650	800 G	900	1050	1150	1250	1350 L	1450	1550 H	1575 Aux		
064	0.75	800	950 G	1100	1300	1500 L	1750	1950 H	2100	2300	2325 Aux		
072	0.75	800	950 G	1100	1300	1500 L	1750	1950 H	2100	2300	2325 Aux		

Factory settings are at recommended G-L-H-Aux speed settings

7/15/22

L-H settings MUST be located within boldface cfm range

"Aux" is factory setting for auxiliary heat and must be equal to or above the "H" setting as well as at least the minimum required for the auxiliary heat package

"G" may be located anywhere within the airflow table

Cfm is controlled within ±5% up to the maximum ESP

Max ESP includes allowance for wet coil and standard filter

Blower Performance Data cont.

Setting Blower Speed - Variable Speed ECM

The ABC board's Yellow Config LED will flash the current ECM blower speed selections for "G", low, and high continuously with a short pause in between. The speeds can also be confirmed with the AID Tool under the Setup/ECM Setup screen. The Aux will not be flashed but can be viewed in the AID Tool. The ECM blower motor speeds can be field adjusted with or without using an AID Tool.

ECM Setup without an AID Tool

The blower speeds for "G", Low (Y1), High (Y2), and Aux can be adjusted directly at the Aurora ABC board which utilizes the push button (SW1) on the ABC board. This procedure is outlined in the ECM Configuration Mode portion of the Aurora 'Base' Control System section. The Aux cannot be set manually without an AID Tool.

ECM Setup with an AID Tool

A much easier method utilizes the AID Tool to change the airflow using the procedure below. First navigate to the Setup screen and then select ECM Setup. This screen displays the current ECM settings. It allows the technician to enter the setup screens to change the ECM settings. Change the highlighted item using the ◀ and ▶ buttons and then press the ⏎ button to select the item.

Selecting YES will enter ECM speed setup, while selecting NO will return to the previous screen.

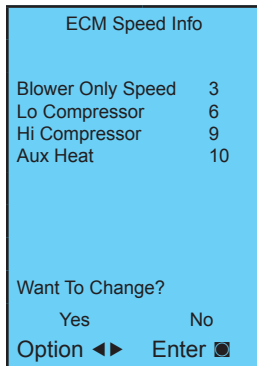

ECM Speed Setup - These screens allow the technician to select the "G", low, high, and auxiliary heat blower speed for the ECM blower motor. Change the highlighted item using the ▲ and ▼ buttons. Press the ⏎ button to select the speed.

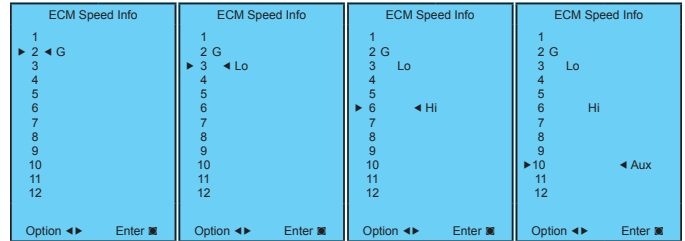

After the auxiliary heat speed setting is selected the AID Tool will automatically transfer back to the ECM Setup screen.

Cooling Airflow Setup - These screens allow the technician to select -15%, -10%, -5%, None or +5%. Change the adjustment percentage using the ▲ and ▼ buttons. Press the ⏎ button to save the change.

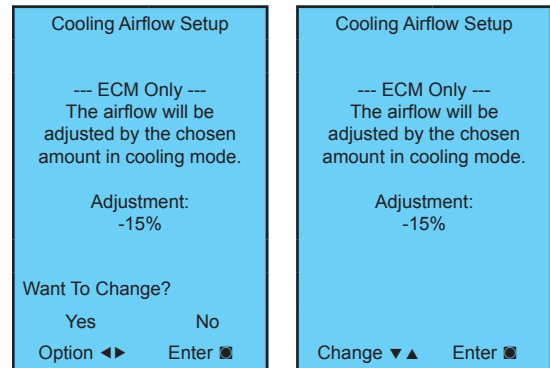

Blower Performance Data cont.

Single Speed Unit with 5-Speed ECM Motor

Model	Motor Speed	Motor Tap	T'stat Cnct.	Blower Size	Motor HP	Airflow (cfm) at External Static Pressure (in. wg)															
						0	0.05	0.10	0.15	0.20	0.25	0.30	0.35	0.40	0.45	0.50	0.60	0.70	0.80	0.90	1.00
022	High	5	W	9 x 7	1/2	980	960	940	930	920	905	890	875	860	840	820	800	745	-	-	-
	Med High	4	Y1			890	878	865	845	825	813	800	785	770	753	735	710	665	-	-	-
	Med	3				830	815	800	788	775	755	735	723	710	690	670	640	600	-	-	-
	Med Low	2	G			780	760	740	703	665	653	640	620	600	585	570	-	-	-	-	-
	Low	1				625	593	560	535	510	495	480	455	430	410	390	-	-	-	-	-
030	High	5		9 x 7	1/2	1407	1381	1354	1327	1300	1267	1233	1201	1168	1131	1094	1009	-	-	-	
	Med High	4	W			1146	1134	1122	1111	1099	1085	1071	1062	1052	1042	1031	966	-	-	-	
	Med	3	Y1			1023	1012	1001	985	969	959	949	937	925	913	901	-	-	-	-	
	Med Low	2				978	962	946	934	922	907	891	882	872	858	843	-	-	-	-	
	Low	1	G			795	777	759	748	737	718	698	686	673	650	626	-	-	-	-	
036	High	5	W	11 x 10	1/2	1530	1503	1476	1453	1429	1413	1397	1376	1355	1342	1329	1276	1231	1173	-	
	Med High	4	Y1			1413	1388	1363	1342	1321	1303	1285	1263	1240	1226	1212	1173	1016	946	-	
	Med	3				1355	1325	1294	1276	1258	1235	1212	1188	1164	1144	1123	982	909	883	-	
	Med Low	2				1336	1299	1261	1242	1222	1202	1181	1157	1132	1111	1090	937	874	830	-	
	Low	1	G			1243	1182	1121	1061	1000	964	928	856	784	744	703	647	592	-	-	
042	High	5		11 x 10	1	1934	1910	1886	1871	1855	1827	1799	1780	1760	1747	1734	1700	1659	1617	-	
	Med High	4	W			1799	1783	1767	1744	1720	1693	1666	1649	1631	1617	1603	1560	1530	1492	-	
	Med	3				1694	1680	1666	1642	1617	1592	1567	1552	1537	1519	1500	1453	1421	1372	-	
	Med Low	2	Y1			1575	1560	1540	1520	1502	1487	1471	1448	1424	1409	1393	1351	1308	1266	-	
	Low	1	G			1454	1406	1358	1333	1308	1285	1261	1239	1217	1198	1179	1072	1002	988	-	
048	High	5		11 x 10	1	1934	1910	1886	1871	1855	1827	1799	1780	1760	1747	1734	1700	1659	1617	-	
	Med High	4	W			1799	1783	1767	1744	1720	1693	1666	1649	1631	1617	1603	1560	1530	1492	-	
	Med	3	Y1			1694	1680	1666	1642	1617	1592	1567	1552	1537	1519	1500	1453	1421	1372	-	
	Med Low	2				1575	1560	1540	1520	1502	1487	1471	1448	1424	1409	1393	1351	1308	1266	-	
	Low	1	G			1454	1406	1358	1333	1308	1285	1261	1239	1217	1198	1179	1072	1002	988	-	
060	High	5	W	11 x 10	1	2245	2230	2214	2194	2173	2155	2136	2120	2103	2087	2070	2032	1998	1957	1910	
	Med High	4				2092	2073	2054	2035	2015	1995	1975	1958	1940	1922	1904	1880	1843	1806	1767	
	Med	3				1951	1931	1910	1889	1868	1850	1831	1812	1793	1774	1755	1722	1688	1654	1612	
	Med Low	2	Y1			1812	1796	1780	1761	1741	1718	1695	1682	1668	1651	1633	1591	1555	1518	1480	
	Low	1	G			1682	1661	1640	1616	1591	1573	1555	1533	1510	1495	1480	1441	1400	1351	1316	
070	High	5	W	11 x 10	1	2472	2454	2435	2414	2393	2371	2349	2328	2306	2289	2271	2230	2189	2121	2033	
	Med High	4	Y1			2271	2248	2225	2205	2184	2166	2147	2129	2110	2094	2078	2039	2011	1977	1930	
	Med	3				2133	2115	2096	2072	2047	2030	2013	1996	1979	1965	1950	1909	1873	1837	1793	
	Med Low	2				2008	1985	1962	1939	1915	1898	1880	1862	1843	1828	1812	1774	1742	1703	1669	
	Low	1	G			1806	1784	1761	1742	1722	1696	1669	1656	1642	1625	1607	1564	1527	1490	1443	

Factory speed settings are in Bold

6/14/12

Air flow values are with dry coil and standard filter

For wet coil performance first calculate the face velocity of the air coil (Face Velocity [fpm] = Airflow [cfm] / Face Area [sq ft]).

Then for velocities of 200 fpm reduce the static capability by 0.03 in. wg, 300 fpm by 0.08 in. wg, 400 fpm by 0.12 in. wg., and 500 fpm by 0.16 in. wg.

Highest setting is for auxiliary heat (W) and lowest setting is for constant blower (G). The "Y1" and "Y2" settings must be between the

"G" and "W" settings.

The gray wire is not factory wired to the motor and is tied to the wire harness. This wire can be field connected and can be used with 3HT/2CL

thermostats or IntelliZone2 to deliver the required air flow for the Y2 signal.

5-Speed ECM Constant Torque Motors

The 5-Speed ECM is a 'Constant Torque' ECM motor and delivers air flow similar to a PSC but operates as efficiently as an ECM Motor. Because it's an ECM Motor, the 5-Speed ECM can ramp slowly up or down like the ECM motor. There are 5 possible speed taps available on the 5-Speed ECM motor with #1 being the lowest airflow and #5 being the highest airflow. These speed selections are preset at the time of manufacture and are easily changed in the field if necessary.

If more than one tap are energized at the same time, built in logic gives precedence to the highest tap number and allows air flow to change with G, Y1, Y2 and W signals or with Fan, CC, CC2, and E1 output signals. Each of those 5 speeds has a specific 'Torque' value programmed into the motor for each speed selection. As static pressure increases, airflow decreases resulting in less torque on the rotor. The motor responds only to changes in torque and adjusts its speed accordingly.

The 5-Speed ECM motor is powered by line voltage but the motor speed is energized by 24 VAC.

5-Speed ECM Benefits:

- High efficiency
- Soft start
- 5 speeds with up to 4 speeds on-line
- Built in logic allows air flow to change with G, Y1, Y2 and W signals
- Super efficient low airflow continuous blower setting (G)

Blower Performance Data cont.

Dual Capacity Unit with 5-Speed ECM

Model	Motor Speed	Motor Tap	T'stat Cnct.	Blower Size	Motor HP	Airflow (cfm) at External Static Pressure (in. wg)															
						0	0.05	0.10	0.15	0.20	0.25	0.30	0.35	0.40	0.45	0.50	0.60	0.70	0.80	0.90	1.00
026	High	5	W	9 x 7	1/2	1120	1109	1097	1082	1066	1055	1044	1028	1011	1001	991	932	839	-	-	-
	Med High	4	Y2			1020	1006	991	980	968	950	932	922	911	894	876	849	812	-	-	-
	Med	3				917	906	895	884	872	854	836	824	812	792	772	754	719	-	-	-
	Med Low	2	Y1			836	824	812	794	776	765	754	735	715	703	691	653	631	-	-	-
	Low	1	G			735	721	707	687	666	653	640	622	603	589	574	533	-	-	-	-
038	High	5	W	11 x 10	1/2	1530	1503	1476	1453	1429	1413	1397	1376	1355	1342	1329	1276	1231	1173	-	-
	Med High	4	Y2			1413	1388	1363	1342	1321	1303	1285	1263	1240	1226	1212	1173	1016	946	-	-
	Med	3	Y1			1355	1325	1294	1276	1258	1235	1212	1188	1164	1144	1123	982	909	883	-	-
	Med Low	2				1336	1299	1261	1242	1222	1202	1181	1157	1132	1111	1090	937	874	830	-	-
	Low	1	G			1243	1182	1121	1061	1000	964	928	856	784	744	703	647	592	-	-	-
049	High	5	W	11 x 10	1	1934	1910	1886	1871	1855	1827	1799	1780	1760	1747	1734	1700	1659	1617	-	-
	Med High	4				1799	1783	1767	1744	1720	1693	1666	1649	1631	1617	1603	1560	1530	1492	-	-
	Med	3	Y2			1694	1680	1666	1642	1617	1592	1567	1552	1537	1519	1500	1453	1421	1372	-	-
	Med Low	2	Y1			1575	1560	1540	1520	1502	1487	1471	1448	1424	1409	1393	1351	1308	1266	-	-
	Low	1	G			1454	1406	1358	1333	1308	1285	1261	1239	1217	1198	1179	1072	1002	988	-	-
064	High	5	W	11 x 10	1	2245	2230	2214	2194	2173	2155	2136	2120	2103	2087	2070	2032	1998	1957	1910	1825
	Med High	4	Y2			2092	2073	2054	2035	2015	1995	1975	1958	1940	1922	1904	1880	1843	1806	1767	1728
	Med	3				1951	1931	1910	1889	1868	1850	1831	1812	1793	1774	1755	1722	1688	1654	1612	1562
	Med Low	2	Y1			1812	1796	1780	1761	1741	1718	1695	1682	1668	1651	1633	1591	1555	1518	1480	1433
	Low	1	G			1682	1661	1640	1616	1591	1573	1555	1533	1510	1495	1480	1441	1400	1351	1316	1263
072	High	5	W	11 x 10	1	2472	2454	2435	2414	2393	2371	2349	2328	2306	2289	2271	2230	2189	2121	2033	1936
	Med High	4	Y2			2271	2248	2225	2205	2184	2166	2147	2129	2110	2094	2078	2039	2011	1977	1930	1846
	Med	3				2133	2115	2096	2072	2047	2030	2013	1996	1979	1965	1950	1909	1873	1837	1793	1748
	Med Low	2	Y1			2008	1985	1962	1939	1915	1898	1880	1862	1843	1828	1812	1774	1742	1703	1669	1635
	Low	1	G			1806	1784	1761	1742	1722	1696	1669	1656	1642	1625	1607	1564	1527	1490	1443	1404

Factory speed settings are in **Bold**
 Air flow values are with dry coil and standard filter
 For wet coil performance first calculate the face velocity of the air coil (Face Velocity [fpm] = Airflow [cfm] / Face Area [sq ft]).
 Then for velocities of 200 fpm reduce the static capability by 0.03 in. wg, 300 fpm by 0.08 in. wg, 400 fpm by 0.12 in. wg., and 500 fpm by 0.16 in. wg.
 Highest setting is for auxiliary heat (W) and lowest setting is for constant blower (G). The "Y1" and "Y2" settings must be between the "G" and "W" settings.

Setting Blower Speed - 5-Speed ECM

5-Speed ECM blower motors have five (5) speeds of which three (3) are selectable on single speed and four (4) are selectable on dual capacity.

 **CAUTION: Disconnect all power before performing this operation.**

5-Speed ECM Motor Connections - Single Speed

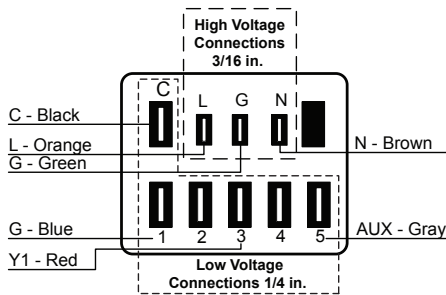

5-Speed ECM Motor Connections - Dual Capacity

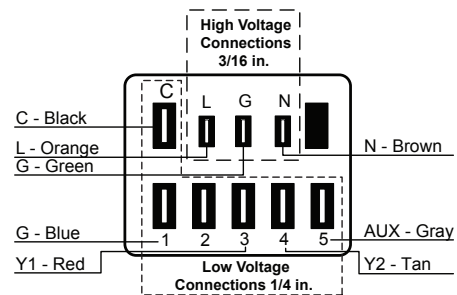

Blower Performance Data cont.

Unit with Standard PSC Motor

Model	Motor Spd	Blower Size	Motor HP	Airflow (cfm) at External Static Pressure (in. wg)															
				0	0.05	0.10	0.15	0.20	0.25	0.30	0.35	0.40	0.45	0.50	0.60	0.70	0.80	0.90	1.00
012	H	6 x 8	1/10	480	450	440	420	410	380	360	340	330	310	300	-	-	-	-	-
	MH*			440	410	400	380	370	350	330	310	300	280	270	-	-	-	-	-
	ML			395	370	360	340	330	310	290	280	270	250	240	-	-	-	-	-
	L			325	310	300	280	270	250	240	230	220	210	200	-	-	-	-	-

7/15/22

Factory settings are in Bold

Air flow values are with dry coil and standard filter

For wet coil performance first calculate the face velocity of the air coil (Face Velocity [fpm] = Airflow [cfm] / Face Area [sq ft]).

Then for velocities of 200 fpm reduce the static capability by 0.03 in. wg, 300 fpm by 0.08 in. wg, 400 fpm by 0.12in. wg. and 500 fpm by 0.16 in. wg.

Setting Blower Speed - PSC



CAUTION: Disconnect all power before performing this operation.

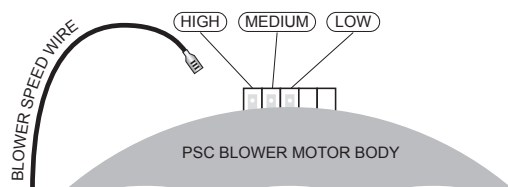

Reference Calculations

Heating Calculations:	Cooling Calculations:
$LWT = EWT - \frac{HE}{gpm \times 500}$	$LWT = EWT + \frac{HR}{gpm \times 500}$
$LAT = EAT + \frac{HC}{cfm \times 1.08}$	$LAT (DB) = EAT (DB) - \frac{SC}{cfm \times 1.08}$
$TH = HC + HW$	$LC = TC - SC$
	$S/T = \frac{SC}{TC}$

Legend and Notes

Abbreviations and Definitions

cfm = airflow, cubic feet/minute	HWC = hot water generator capacity, MBtu/h
EWT = entering water temperature, Fahrenheit	EER = Energy Efficient Ratio
gpm = water flow in gallons/minute	= Btu output/Watt input
WPD = water pressure drop, psi and feet of water	COP = Coefficient of Performance
EAT = entering air temperature, Fahrenheit (dry bulb/wet bulb)	= Btu output/Btu input
HC = air heating capacity, MBtu/h	LWT = leaving water temperature, °F
TC = total cooling capacity, MBtu/h	LAT = leaving air temperature, °F
SC = sensible cooling capacity, MBtu/h	TH = total heating capacity, MBtu/h
KW = total power unit input, kilowatts	LC = latent cooling capacity, MBtu/h
HR = total heat of rejection, MBtu/h	S/T = sensible to total cooling ratio
HE = total heat of extraction, MBtu/h	

Notes to Performance Data Tables

The following notes apply to all performance data tables:

- Performance ratings are based on 80°F DB/67°F WB EAT for cooling and 70°F DB EAT for heating.
- Three flow rates are shown for each unit. The lowest flow rate shown is used for geothermal open loop/well water systems with a minimum of 50°F EWT. The middle flow rate shown is the minimum geothermal closed loop flow rate. The highest flow rate shown is optimum for geothermal closed loop systems and the suggested flow rate for boiler/tower applications.
- The hot water generator numbers are based on a flow rate of 0.4 gpm/ton of rated capacity with an EWT of 90°F.
- Entering water temperatures below 40°F assumes 15% antifreeze solution.
- For non-standard EAT conditions, apply the appropriate Correction Factor tables.
- Interpolation between EWT, gpm, and cfm data is permissible, extrapolation is not.

Operating Limits

Operating Limits	Cooling		Heating	
	(°F)	(°C)	(°F)	(°C)
Air Limits				
Min. Ambient Air	45	7.2	45	7.2
Rated Ambient Air	80	26.7	70	21.1
Max. Ambient Air	100	37.8	85	29.4
Min. Entering Air	50	10.0	40	4.4
Rated Entering Air db/wb	80.6/66.2	27/19	68	20.0
Max. Entering Air db/wb	110/83	43/28.3	80	26.7
Water Limits				
Min. Entering Water	30	-1.1	20	-6.7
Normal Entering Water	50-110	10-43.3	30-70	-1.1
Max. Entering Water	120	48.9	90	32.2

NOTE: Minimum/maximum limits are only for start-up conditions, and are meant for bringing the space up to occupancy temperature. Units are not designed to operate at the minimum/maximum conditions on a regular basis. The operating limits are dependent upon three primary factors: 1) water temperature, 2) return air temperature, and 3) ambient temperature. When any of the factors are at the minimum or maximum levels, the other two factors must be at the normal level for proper and reliable unit operation.

Antifreeze Corrections

Catalog performance can be corrected for antifreeze use. Please use the following table and note the example given.

Antifreeze Type EWT - °F [°C]	Antifreeze % by wt	Heating 30 [-1.1]	Cooling 90 [32.2]	Pressure Drop 30 [-1.1]
Water	0	1.000	1.000	1.000
Ethylene Glycol	10	0.973	0.991	1.075
	20	0.943	0.979	1.163
	30	0.917	0.965	1.225
	40	0.890	0.955	1.324
	50	0.865	0.943	1.419
Propylene Glycol	10	0.958	0.981	1.130
	20	0.913	0.969	1.270
	30	0.854	0.950	1.433
	40	0.813	0.937	1.614
	50	0.770	0.922	1.816
Ethanol	10	0.927	0.991	1.242
	20	0.887	0.972	1.343
	30	0.856	0.947	1.383
	40	0.815	0.930	1.523
	50	0.779	0.911	1.639
Methanol	10	0.957	0.986	1.127
	20	0.924	0.970	1.197
	30	0.895	0.951	1.235
	40	0.863	0.936	1.323
	50	0.833	0.920	1.399



WARNING: Gray area represents antifreeze concentrations greater than 35% by weight and should be avoided due to the extreme performance penalty they represent.

Antifreeze Correction Example

Antifreeze solution is Propylene Glycol 20% by weight. Determine the corrected heating and cooling performance at 30°F and 90°F respectively as well as pressure drop at 30°F for a Aston Series Single Speed Model 022-ECM.

The corrected cooling capacity at 90°F would be: 22,400 MBtu/h x 0.969 = 21,706 MBtu/h

The corrected heating capacity at 30°F would be: 14,500 MBtu/h x 0.913 = 13,239 MBtu/h

The corrected pressure drop at 30°F and 6 gpm would be: 6.6 feet of head x 1.270 = 8.38 feet of head

Correction Factor Tables

Air Flow Corrections (Dual Capacity Part Load)

Airflow		Cooling				Heating		
cfm Per Ton of Clg	% of Nominal	Total Cap	Sens Cap	Power	Heat of Rej	Htg Cap	Power	Heat of Ext
240	60	0.922	0.778	0.956	0.924	0.943	1.239	0.879
275	69	0.944	0.830	0.962	0.944	0.958	1.161	0.914
300	75	0.957	0.866	0.968	0.958	0.968	1.115	0.937
325	81	0.970	0.900	0.974	0.970	0.977	1.075	0.956
350	88	0.982	0.933	0.981	0.980	0.985	1.042	0.972
375	94	0.991	0.968	0.991	0.991	0.993	1.018	0.988
400	100	1.000	1.000	1.000	1.000	1.000	1.000	1.000
425	106	1.007	1.033	1.011	1.008	1.007	0.990	1.010
450	113	1.013	1.065	1.023	1.015	1.012	0.987	1.018
475	119	1.017	1.099	1.037	1.022	1.018	0.984	1.025
500	125	1.020	1.132	1.052	1.027	1.022	0.982	1.031
520	130	1.022	1.159	1.064	1.030	1.025	0.979	1.034

5/30/06

Air Flow Corrections (Dual Capacity Full Load and Single Speed)

Airflow		Cooling				Heating		
cfm Per Ton of Clg	% of Nominal	Total Cap	Sens Cap	Power	Heat of Rej	Htg Cap	Power	Heat of Ext
240	60	0.922	0.786	0.910	0.920	0.943	1.150	0.893
275	69	0.944	0.827	0.924	0.940	0.958	1.105	0.922
300	75	0.959	0.860	0.937	0.955	0.968	1.078	0.942
325	81	0.971	0.894	0.950	0.967	0.977	1.053	0.959
350	88	0.982	0.929	0.964	0.978	0.985	1.031	0.973
375	94	0.992	0.965	0.982	0.990	0.993	1.014	0.988
400	100	1.000	1.000	1.000	1.000	1.000	1.000	1.000
425	106	1.007	1.034	1.020	1.010	1.007	0.990	1.011
450	113	1.012	1.065	1.042	1.018	1.013	0.983	1.020
475	119	1.017	1.093	1.066	1.026	1.018	0.980	1.028
500	125	1.019	1.117	1.092	1.033	1.023	0.978	1.034
520	130	1.020	1.132	1.113	1.038	1.026	0.975	1.038

5/30/06

Cooling Capacity Corrections

Entering Air WB °F	Total Clg Cap	Sensible Cooling Capacity Multipliers - Entering DB °F										Power Input	Heat of Rejection
		60	65	70	75	80	80.6	85	90	95	100		
55	0.898	0.723	0.866	1.048	1.185	*	*	*	*	*	*	0.985	0.913
60	0.912		0.632	0.880	1.078	1.244	1.260	*	*	*	*	0.994	0.927
63	0.945			0.768	0.960	1.150	1.175	*	*	*	*	0.996	0.954
65	0.976			0.694	0.881	1.079	1.085	1.270	*	*	*	0.997	0.972
66.2	0.983			0.655	0.842	1.040	1.060	1.232	*	*	*	0.999	0.986
67	1.000			0.616	0.806	1.000	1.023	1.193	1.330	1.480	*	1.000	1.000
70	1.053				0.693	0.879	0.900	1.075	1.205	1.404	*	1.003	1.044
75	1.168					0.687	0.715	0.875	1.040	1.261	1.476	1.007	1.141

NOTE: * Sensible capacity equals total capacity at conditions shown.

3/28/12

Heating Capacity Corrections

Ent Air DB °F	Heating Corrections		
	Htg Cap	Power	Heat of Ext
45	1.062	0.739	1.158
50	1.050	0.790	1.130
55	1.037	0.842	1.096
60	1.025	0.893	1.064
65	1.012	0.945	1.030
68	1.005	0.976	1.012
70	1.000	1.000	1.000
75	0.987	1.048	0.970
80	0.975	1.099	0.930

11/10/09

Pressure Drop

Single Speed

Model	gpm	Pressure Drop (psi)				
		30°F	50°F	70°F	90°F	110°F
012	1.5	0.3	0.3	0.3	0.3	0.3
	2.5	1.0	1.0	1.0	1.0	1.0
	3.5	1.7	1.7	1.7	1.6	1.6
	4.5	2.5	2.4	2.4	2.4	2.3
018	3.0	1.6	1.6	1.5	1.5	1.4
	4.0	2.9	2.9	2.8	2.8	2.7
	5.0	4.2	4.2	4.1	4.0	3.9
	6.0	6.0	5.8	5.7	5.6	5.5
022	3	0.9	0.9	0.8	0.7	0.7
	4.5	1.7	1.6	1.5	1.4	1.3
	6	2.8	2.7	2.5	2.3	2.2
	8	4.7	4.4	4.1	3.9	3.6
030	4	1.3	1.2	1.2	1.1	1.0
	6	2.7	2.5	2.4	2.2	2.2
	8	4.5	4.2	3.9	3.7	3.4
	10	6.8	6.3	5.4	5.4	5.0
036	5	1.0	1.0	0.9	0.8	0.8
	7	2.1	1.9	1.8	1.7	1.6
	9	3.6	3.3	3.0	2.8	2.6
	12	6.3	5.9	5.5	5.1	4.8
042	5	0.8	0.7	0.7	0.7	0.6
	8	2.1	2.1	1.9	1.8	1.7
	11	4.2	4.1	3.8	3.5	3.3
	14	7.6	6.7	6.3	5.8	5.4
048	6	1.1	1.0	1.0	0.9	0.8
	9	2.3	2.1	2.0	1.9	1.7
	12	3.9	3.7	3.4	3.2	3.0
	16	6.7	6.3	5.9	5.5	5.1
060	9	2.4	2.2	2.1	2.0	1.8
	12	3.9	3.6	3.4	3.2	2.9
	15	5.7	5.3	5.0	4.7	4.3
	20	9.5	8.9	8.3	7.8	7.2
070	12	3.0	2.8	2.6	2.4	2.2
	15	4.4	4.0	3.8	3.5	3.3
	18	6.0	5.5	5.1	4.8	4.4
	24	9.7	9.1	8.5	7.9	7.3

2/7/12

Dual Capacity

Model	gpm	Pressure Drop (psi)				
		30°F	50°F	70°F	90°F	110°F
026 full load	4	1.4	1.3	1.2	1.1	1.0
	6	2.8	2.6	2.4	2.3	2.1
	8	4.7	4.4	4.1	3.8	3.5
	10	7.0	6.6	6.2	5.8	5.3
026 part load	3	0.8	0.7	0.7	0.7	0.6
	5	2.0	1.8	1.7	1.6	1.5
	7	3.6	3.4	3.2	3.0	2.8
	9	5.8	5.5	5.1	4.8	4.4
038 full load	5	1.2	1.2	1.1	1.0	1.0
	7	2.2	2.1	1.9	1.8	1.7
	9	3.4	3.2	3.0	2.8	2.6
	11	4.9	4.6	4.3	4	3.7
038 part load	4	0.9	0.8	0.8	0.7	0.7
	6	1.7	1.6	1.5	1.4	1.3
	8	2.8	2.6	2.5	2.3	2.1
	10	4.2	3.9	3.7	3.4	3.2
049 full load	6	1.2	1.2	1.1	1.0	1.0
	9	2.4	2.2	2.1	2.0	1.8
	12	3.9	3.6	3.4	3.2	2.9
	15	5.7	5.3	5	4.7	4.3
049 part load	5	0.9	0.9	0.8	0.8	0.7
	8	2.0	1.8	1.7	1.6	1.5
	11	3.4	3.1	2.9	2.8	2.5
	14	5.0	4.7	4.4	4.1	3.8
064 full load	8	1.8	1.7	1.6	1.4	1.3
	12	3.8	3.5	3.3	3.0	2.8
	16	6.5	6.0	5.6	5.2	4.8
	20	9.7	9.1	8.5	8.0	7.4
064 part load	6	1.0	0.9	0.9	0.8	0.8
	10	2.6	2.5	2.3	2.1	2.0
	14	5.0	4.7	4.4	4.1	3.8
	18	8.1	7.6	7.1	6.6	6.1
072 full load	12	3.2	3.0	2.8	2.6	2.4
	15	4.5	4.2	4.0	3.7	3.4
	18	6.0	5.7	5.3	4.9	4.6
	21	7.8	7.3	6.8	6.4	5.9
072 part load	10	2.3	2.1	2.0	1.9	1.7
	13	3.6	3.3	3.0	2.8	2.6
	16	5.0	4.6	4.3	4.0	3.7
	19	6.5	6.2	5.8	5.4	5.0

1/26/12

Performance Data

Model 012 - Single Speed PSC (400 cfm)

EWT °F	Flow Rate GPM	WPD		Heating - EAT 70 °F					Cooling - EAT 80/67 °F					
		PSI	FT/HD	HC MBtu/h	Power kW	HE MBtu/h	LAT °F	COP	TC MBtu/h	SC MBtu/h	S/T Ratio	Power kW	HR MBtu/h	EER
20	1.5	0.3	0.7	Operation not recommended					Operation not recommended					
	2.5	1.0	2.3	Operation not recommended					Operation not recommended					
	3.5	1.7	3.9	7.5	0.78	4.8	85.3	2.80	Operation not recommended					
30	1.5	0.3	0.7	Operation not recommended					Operation not recommended					
	2.5	1.0	2.3	9.0	0.80	6.3	88.8	3.29	16.3	10.3	0.63	0.43	17.8	37.7
	3.5	1.7	3.9	9.1	0.81	6.3	89.1	3.29	16.5	10.3	0.62	0.41	18.0	40.2
40	1.5	0.3	0.7	Operation not recommended					Operation not recommended					
	2.5	1.0	2.3	10.0	0.82	7.2	91.1	3.57	15.8	10.1	0.64	0.49	17.4	31.9
	3.5	1.7	3.9	10.3	0.83	7.4	91.7	3.64	16.0	10.1	0.63	0.46	17.6	34.9
50	1.5	0.3	0.7	10.6	0.83	7.8	92.5	3.75	15.0	10.0	0.66	0.61	17.1	24.6
	2.5	1.0	2.3	11.0	0.83	8.2	93.5	3.86	15.2	9.9	0.65	0.56	17.1	27.3
	3.5	1.7	3.8	11.4	0.84	8.5	94.4	3.97	15.5	9.9	0.64	0.51	17.2	30.6
60	1.5	0.3	0.7	11.8	0.85	8.9	95.2	4.08	14.5	9.7	0.67	0.69	16.9	21.1
	2.5	1.0	2.3	12.2	0.85	9.3	96.3	4.21	14.7	9.7	0.66	0.64	16.9	23.1
	3.5	1.7	3.8	12.7	0.86	9.8	97.4	4.33	14.9	9.7	0.65	0.59	16.9	25.3
70	1.5	0.3	0.7	12.9	0.86	10.0	98.0	4.40	14.1	9.4	0.67	0.77	16.7	18.3
	2.5	1.0	2.3	13.5	0.87	10.5	99.2	4.54	14.2	9.5	0.67	0.72	16.7	19.8
	3.5	1.7	3.8	14.0	0.88	11.0	100.4	4.67	14.4	9.6	0.67	0.67	16.7	21.4
80	1.5	0.3	0.7	14.3	0.88	11.3	101.2	4.76	13.6	9.2	0.68	0.87	16.6	15.7
	2.5	1.0	2.2	14.9	0.89	11.9	102.6	4.92	13.8	9.3	0.68	0.82	16.6	16.8
	3.5	1.6	3.8	15.3	0.90	12.2	103.4	5.00	13.9	9.4	0.68	0.76	16.5	18.2
90	1.5	0.3	0.7	15.8	0.90	12.8	104.7	5.15	13.2	9.0	0.68	0.97	16.5	13.6
	2.5	1.0	2.2	16.5	0.91	13.4	106.3	5.34	13.3	9.2	0.69	0.93	16.5	14.2
	3.5	1.6	3.8	16.6	0.92	13.5	106.4	5.32	13.4	9.2	0.69	0.85	16.3	15.7
100	1.5	0.3	0.7	Operation not recommended					Operation not recommended					
	2.5	1.0	2.2						12.9	9.0	0.70	1.06	16.5	12.1
	3.5	1.6	3.7						13.0	9.1	0.70	0.95	16.2	13.7
110	1.5	0.3	0.7						Operation not recommended					
	2.5	1.0	2.2						12.4	8.8	0.71	1.21	16.5	10.3
120	3.5	1.6	3.6						12.6	8.9	0.71	1.05	16.2	12.0
	1.5	0.3	0.7	Operation not recommended										
120	2.5	1.0	2.2	12.0	8.6	0.72	1.37	16.7	8.8					
	3.5	1.5	3.5	12.1	8.7	0.72	1.16	16.0	10.5					

10/1/10

Performance Data cont.

Model 018 - Single Speed with Variable Speed ECM (600 cfm)

EWT °F	Flow Rate GPM	WPD		Heating - EAT 70°F							Cooling - EAT 80/67 °F							
		PSI	FT/HD	Airflow cfm	HC MBtu/h	Power kW	HE MBtu/h	LAT °F	COP	HWC MBtu/h	Airflow cfm	TC MBtu/h	SC MBtu/h	S/T Ratio	Power kW	HR MBtu/h	EER	HWC MBtu/h
20	3.0	1.8	4.1	Operation not recommended							Operation not recommended							
	4.0	3.0	6.9	Operation not recommended							Operation not recommended							
	5.0	4.3	9.9	500	12.3	1.09	8.6	90.8	3.30	1.6	Operation not recommended							
				600	12.7	1.12	8.9	87.6	3.34	1.5	Operation not recommended							
30	3.0	1.7	3.9	Operation not recommended							Operation not recommended							
	4.0	3.0	6.8	500	13.9	1.16	10.0	93.8	3.51	1.6	500	19.0	11.6	0.61	0.65	21.2	29.4	--
				600	14.4	1.19	10.3	90.2	3.55	1.6	600	19.5	12.9	0.66	0.70	21.9	28.1	--
				500	14.2	1.17	10.2	94.2	3.54	1.7	500	18.3	11.2	0.61	0.63	20.4	29.1	--
	5.0	4.2	9.7	600	14.6	1.20	10.5	90.5	3.58	1.6	600	18.8	12.4	0.66	0.68	21.1	27.9	--
40	3.0	1.7	3.8	Operation not recommended							Operation not recommended							
	4.0	2.9	6.7	500	15.4	1.22	11.2	96.5	3.70	1.8	500	19.4	11.7	0.60	0.69	21.8	28.0	--
				600	15.9	1.24	11.6	92.5	3.74	1.6	600	20.0	13.0	0.65	0.75	22.5	26.8	--
				500	15.8	1.23	11.6	97.2	3.76	1.8	500	19.2	11.5	0.60	0.64	21.4	29.9	--
	5.0	4.2	9.6	600	16.3	1.26	12.0	93.1	3.79	1.7	600	19.8	12.8	0.65	0.69	22.1	28.6	--
50	3.0	1.6	3.7	500	16.6	1.27	12.3	98.7	3.83	1.9	500	19.6	11.9	0.61	0.82	22.4	23.8	0.9
				600	17.1	1.30	12.7	94.4	3.87	1.7	600	20.1	13.2	0.66	0.89	23.1	22.7	1.0
	4.0	2.9	6.6	500	17.0	1.28	12.6	99.4	3.89	1.9	500	19.8	11.8	0.60	0.74	22.4	26.8	0.8
				600	17.5	1.31	13.0	95.0	3.93	1.8	600	20.4	13.2	0.64	0.80	23.1	25.7	0.9
				500	17.4	1.29	13.0	100.2	3.95	1.9	500	20.1	11.8	0.59	0.66	22.4	30.7	0.8
	5.0	4.2	9.6	600	17.9	1.32	13.4	95.6	3.99	1.9	600	20.7	13.1	0.63	0.71	23.1	29.4	0.9
60	3.0	1.6	3.6	500	18.5	1.33	13.9	102.2	4.08	2.1	500	18.7	11.4	0.61	0.87	21.6	21.5	1.0
				600	19.1	1.36	14.4	97.4	4.12	2.0	600	19.2	12.7	0.66	0.94	22.4	20.5	1.1
	4.0	2.8	6.6	500	18.8	1.34	14.3	102.9	4.11	2.1	500	18.9	11.4	0.60	0.81	21.7	23.2	1.0
				600	19.4	1.37	14.8	98.0	4.16	2.0	600	19.4	12.6	0.65	0.88	22.4	22.2	1.1
				500	19.2	1.36	14.6	103.6	4.15	2.2	500	19.1	11.3	0.59	0.76	21.7	25.2	0.9
	5.0	4.1	9.5	600	19.8	1.39	15.1	98.6	4.19	2.0	600	19.6	12.6	0.64	0.82	22.4	24.0	1.0
70	3.0	1.5	3.5	500	20.4	1.39	15.6	105.7	4.31	2.4	500	17.8	10.9	0.61	0.92	20.9	19.4	1.2
				600	21.0	1.42	16.2	100.4	4.35	2.2	600	18.3	12.1	0.66	0.99	21.7	18.6	1.3
	4.0	2.8	6.5	500	20.7	1.41	15.9	106.4	4.32	2.4	500	17.9	10.9	0.61	0.89	20.9	20.2	1.1
				600	21.4	1.44	16.5	100.9	4.36	2.2	600	18.4	12.1	0.66	0.96	21.7	19.3	1.3
				500	21.0	1.43	16.2	107.0	4.33	2.4	500	18.0	10.9	0.60	0.86	20.9	20.9	1.1
	5.0	4.1	9.5	600	21.7	1.46	16.7	101.5	4.37	2.2	600	18.5	12.1	0.65	0.93	21.7	20.0	1.2
80	3.0	1.5	3.4	500	22.6	1.45	17.7	109.9	4.57	2.7	500	17.0	10.4	0.61	0.97	20.3	17.6	1.6
				600	23.3	1.48	18.3	104.0	4.62	2.5	600	17.5	11.6	0.66	1.04	21.0	16.8	1.7
	4.0	2.8	6.4	500	22.9	1.48	17.9	110.4	4.55	2.7	500	17.0	10.4	0.61	0.97	20.3	17.5	1.5
				600	23.6	1.51	18.5	104.5	4.60	2.4	600	17.5	11.6	0.66	1.05	21.1	16.7	1.6
				500	23.3	1.49	18.2	111.1	4.58	2.7	500	17.2	10.6	0.62	0.95	20.4	18.1	1.4
	5.0	4.1	9.4	600	24.0	1.52	18.8	105.0	4.63	2.5	600	17.7	11.8	0.67	1.02	21.1	17.3	1.5
90	3.0	1.4	3.2	500	25.1	1.52	19.9	114.4	4.85	3.0	500	16.2	10.0	0.62	1.02	19.7	15.9	1.9
				600	25.8	1.55	20.6	107.9	4.90	2.8	600	16.7	11.1	0.67	1.10	20.4	15.2	2.1
	4.0	2.7	6.3	500	25.3	1.55	20.0	114.9	4.79	3.0	500	16.2	10.0	0.62	1.07	19.8	15.1	1.8
				600	26.1	1.58	20.7	108.3	4.84	2.8	600	16.6	11.1	0.67	1.15	20.5	14.5	2.0
				500	25.5	1.55	20.2	115.2	4.81	3.1	500	16.3	10.3	0.63	1.04	19.9	15.7	1.7
	5.0	4.0	9.2	600	26.3	1.59	20.9	108.6	4.86	2.9	600	16.8	11.4	0.68	1.12	20.6	15.0	1.9
100	3.0	1.4	3.1	Operation not recommended							Operation not recommended							
	4.0	2.7	6.2	Operation not recommended							500	15.3	9.6	0.63	1.17	19.3	13.1	2.2
				600	15.8	10.7	0.68	1.26	20.1	12.5	2.4							
				500	15.3	9.9	0.65	1.19	19.4	12.9	2.0							
5.0	4.0	9.1	Operation not recommended							600	15.8	11.1	0.70	1.28	20.1	12.3	2.3	
110	3.0	1.3	3.0	Operation not recommended							Operation not recommended							
	4.0	2.7	6.1	Operation not recommended							500	14.6	9.2	0.63	1.28	19.0	11.4	2.9
				600	15.0	10.2	0.68	1.38	19.7	10.9	3.2							
				500	14.3	9.6	0.67	1.33	18.9	10.7	2.6							
5.0	3.9	9.0	Operation not recommended							600	14.7	10.7	0.73	1.44	19.6	10.2	3.0	
120	3.0	1.3	2.9	Operation not recommended							Operation not recommended							
	4.0	2.6	6.1	Operation not recommended							500	13.8	8.8	0.64	1.41	18.6	9.8	3.5
				600	14.2	9.8	0.69	1.51	19.4	9.4	4.0							
				500	13.3	9.2	0.69	1.48	18.4	9.0	3.1							
5.0	3.9	8.9	Operation not recommended							600	13.7	10.2	0.74	1.60	19.1	8.6	3.5	

Performance Data cont.

Model 022 - Single Speed with Variable Speed ECM or 5-Speed ECM (700 cfm)

EWT °F	Flow Rate GPM	WPD		HEATING - EAT 70°F							COOLING - EAT 80/67 °F							
		PSI	FT/HD	Airflow CFM	HC MBtu/h	Power kW	HE MBtu/h	LAT °F	COP	HWC Mbtu/h	Airflow CFM	TC Mbtu/h	SC Mbtu/h	S/T Ratio	Power kW	HR Mbtu/h	EER	HWC Mbtu/h
20	3.0	0.9	2.2	Operation not recommended							Operation not recommended							
	4.5	1.8	4.2	Operation not recommended							Operation not recommended							
	6.0	2.9	6.8	600	12.0	1.16	8.0	88.4	3.03	1.6	Operation not recommended							
				700	12.1	1.17	8.1	86.0	3.04	1.5	Operation not recommended							
30	3.0	0.9	2.1	Operation not recommended							Operation not recommended							
	4.5	1.7	4.0	600	14.0	1.17	10.0	91.6	3.53	1.7	600	23.4	15.8	0.68	0.66	25.7	35.6	---
				700	14.3	1.18	10.3	88.9	3.57	1.6	700	23.8	17.3	0.73	0.69	26.2	34.4	---
	6.0	2.8	6.6	600	14.3	1.18	10.3	92.1	3.57	1.8	600	23.6	15.8	0.67	0.64	25.7	36.9	---
				700	14.5	1.19	10.5	89.2	3.59	1.6	700	24.1	17.3	0.72	0.67	26.4	36.0	---
40	3.0	0.9	2.0	Operation not recommended							Operation not recommended							
	4.5	1.7	3.9	600	16.5	1.19	12.5	95.5	4.06	1.9	600	24.9	16.3	0.65	0.71	27.3	35.3	---
				700	16.9	1.20	12.8	92.3	4.12	1.8	700	25.4	17.8	0.70	0.74	27.9	34.3	---
	6.0	2.8	6.4	600	16.8	1.21	12.7	96.0	4.08	2.0	600	25.1	16.3	0.65	0.68	27.5	36.7	---
				700	17.1	1.21	13.0	92.7	4.16	1.8	700	25.7	17.8	0.69	0.72	28.1	35.9	---
50	3.0	0.9	2.0	600	18.0	1.20	13.9	97.7	4.39	2.1	600	25.4	16.0	0.63	0.83	28.2	30.7	1.1
				700	18.3	1.20	14.2	94.2	4.48	2.0	700	25.9	17.5	0.67	0.86	28.8	30.1	1.2
	4.5	1.6	3.8	600	18.9	1.23	14.7	99.1	4.51	2.2	600	25.6	16.2	0.63	0.79	28.3	32.6	1.0
				700	19.2	1.23	15.0	95.4	4.60	2.0	700	26.2	17.7	0.67	0.82	29.0	31.9	1.1
	6.0	2.7	6.2	600	19.1	1.24	14.9	99.5	4.51	2.2	600	25.9	16.2	0.63	0.76	28.5	34.0	1.0
				700	19.6	1.23	15.4	95.9	4.65	2.1	700	26.4	17.7	0.67	0.79	29.2	33.3	1.1
60	3.0	0.8	1.9	600	20.3	1.25	16.0	101.3	4.77	2.4	600	24.6	15.9	0.65	0.93	27.7	26.5	1.3
				700	20.7	1.23	16.5	97.4	4.93	2.2	700	25.1	17.3	0.69	0.96	28.4	26.0	1.4
	4.5	1.6	3.7	600	21.2	1.27	16.9	102.7	4.89	2.4	600	24.8	16.1	0.65	0.88	27.8	28.3	1.2
				700	21.8	1.26	17.5	98.8	5.05	2.3	700	25.3	17.5	0.69	0.91	28.5	27.7	1.3
	6.0	2.6	6.0	600	21.6	1.29	17.2	103.3	4.91	2.5	600	25.1	16.1	0.64	0.85	28.0	29.4	1.1
			700	22.1	1.27	17.8	99.3	5.10	2.3	700	25.6	17.5	0.68	0.89	28.6	28.9	1.3	
70	3.0	0.8	1.8	600	22.6	1.30	18.2	104.9	5.11	2.7	600	24.3	15.8	0.65	1.05	27.8	23.1	1.6
				700	23.2	1.27	18.8	100.6	5.34	2.5	700	24.7	17.1	0.69	1.09	28.5	22.7	1.7
	4.5	1.5	3.6	600	23.6	1.32	19.1	106.4	5.23	2.7	600	24.5	15.9	0.65	0.99	27.8	24.6	1.5
				700	24.3	1.30	19.9	102.2	5.46	2.5	700	25.0	17.3	0.69	1.03	28.6	24.2	1.7
	6.0	2.5	5.8	600	24.1	1.34	19.5	107.1	5.27	2.8	600	24.7	15.9	0.64	0.97	28.0	25.6	1.4
			700	24.7	1.31	20.2	102.7	5.51	2.6	700	25.2	17.3	0.69	1.00	28.6	25.2	1.6	
80	3.0	0.8	1.8	600	24.6	1.35	20.0	108.0	5.34	3.0	600	23.2	15.4	0.66	1.19	27.3	19.5	2.0
				700	25.3	1.32	20.8	103.5	5.64	2.8	700	23.7	16.7	0.71	1.23	27.9	19.2	2.2
	4.5	1.5	3.4	600	25.7	1.38	21.0	109.6	5.45	3.1	600	23.4	15.6	0.66	1.13	27.3	20.8	1.9
				700	26.5	1.35	21.9	105.1	5.78	2.8	700	24.0	16.9	0.71	1.16	27.9	20.6	2.1
	6.0	2.4	5.6	600	26.1	1.40	21.4	110.3	5.48	3.2	600	23.7	15.6	0.66	1.09	27.4	21.7	1.8
			700	27.0	1.36	22.3	105.7	5.82	2.9	700	24.2	16.9	0.70	1.13	28.0	21.4	2.0	
90	3.0	0.7	1.7	600	26.6	1.41	21.8	111.1	5.53	3.3	600	21.5	15.0	0.70	1.35	26.1	15.9	2.5
				700	27.5	1.37	22.9	106.4	5.90	3.1	700	22.0	16.3	0.74	1.39	26.8	15.8	2.7
	4.5	1.4	3.3	600	27.8	1.44	22.9	112.9	5.64	3.4	600	21.7	15.2	0.70	1.28	26.1	17.0	2.4
				700	28.8	1.39	24.0	108.0	6.05	3.2	700	22.2	16.5	0.74	1.32	26.7	16.9	2.6
	6.0	2.3	5.4	600	28.2	1.46	23.2	113.6	5.66	3.5	600	22.0	15.2	0.69	1.24	26.2	17.8	2.2
			700	29.3	1.41	24.5	108.7	6.09	3.3	700	22.4	16.5	0.74	1.28	26.8	17.5	2.4	
100	3.0	0.7	1.7	Operation not recommended							Operation not recommended							
	4.5	1.4	3.2	Operation not recommended							Operation not recommended							
	6.0	2.2	5.2	Operation not recommended							600	20.8	14.8	0.71	1.45	25.7	14.3	2.9
				Operation not recommended							700	21.2	16.1	0.76	1.49	26.3	14.2	3.2
110	3.0	0.7	1.6	Operation not recommended							Operation not recommended							
	4.5	1.3	3.1	Operation not recommended							Operation not recommended							
	6.0	2.2	5.0	Operation not recommended							600	21.0	14.8	0.70	1.41	25.8	15.0	2.7
				Operation not recommended							700	21.4	16.1	0.75	1.45	26.4	14.8	3.0
				Operation not recommended							600	18.6	14.3	0.76	1.63	24.2	11.4	3.6
			Operation not recommended							700	19.0	15.5	0.81	1.68	24.8	11.3	3.9	
120	3.0	0.7	1.5	Operation not recommended							Operation not recommended							
	4.5	1.3	2.9	Operation not recommended							Operation not recommended							
	6.0	2.1	4.8	Operation not recommended							600	17.3	13.8	0.79	1.86	23.7	9.3	4.3
				Operation not recommended							700	17.6	14.9	0.85	1.91	24.2	9.3	4.7
			Operation not recommended							600	17.5	13.8	0.79	1.80	23.6	9.7	4.0	
			Operation not recommended							700	17.9	14.9	0.84	1.86	24.2	9.6	4.4	

Performance Data cont.

Model 030 - Single Speed with Variable Speed ECM or 5-Speed ECM (900 cfm)

EWT °F	Flow Rate GPM	WPD		HEATING - EAT 70°F							COOLING - EAT 80/67 °F							
		PSI	FT/HD	Airflow CFM	HC MBtu/h	Power kW	HE MBtu/h	LAT °F	COP	HWC Mbtu/h	Airflow CFM	TC Mbtu/h	SC Mbtu/h	S/T Ratio	Power kW	HR Mbtu/h	EER	HWC Mbtu/h
20	4.0	1.4	3.5	Operation not recommended							Operation not recommended							
	6.0	2.8	7.2	Operation not recommended							Operation not recommended							
	8.0	4.6	12.1	700	16.9	1.52	11.7	92.4	3.26	2.2	Operation not recommended							
				900	17.2	1.55	11.9	87.7	3.25	2.0	Operation not recommended							
30	4.0	1.4	3.4	Operation not recommended							Operation not recommended							
	6.0	2.7	7.0	700	19.4	1.51	14.2	95.7	3.77	2.4	700	26.1	16.7	0.64	0.87	29.1	30.0	---
				900	19.8	1.54	14.6	90.4	3.77	2.2	900	26.8	18.7	0.70	0.94	30.0	28.5	---
	8.0	4.4	11.8	700	19.9	1.53	14.7	96.3	3.82	2.4	700	26.3	16.7	0.63	0.85	29.2	30.8	---
				900	20.2	1.56	14.9	90.8	3.81	2.2	900	27.3	18.7	0.68	0.91	30.4	30.0	---
40	4.0	1.3	3.3	Operation not recommended							Operation not recommended							
	6.0	2.6	6.8	700	22.7	1.56	17.4	100.1	4.27	2.6	700	28.3	18.0	0.64	0.95	31.5	29.7	---
				900	23.3	1.58	17.9	93.9	4.31	2.4	900	29.1	20.2	0.70	1.02	32.6	28.4	---
	8.0	4.3	11.4	700	23.3	1.58	17.9	100.8	4.32	2.7	700	28.5	18.0	0.63	0.93	31.7	30.5	---
				900	23.8	1.60	18.3	94.5	4.36	2.5	900	29.5	20.2	0.68	0.99	32.9	29.7	---
50	4.0	1.3	3.2	700	24.9	1.60	19.4	102.9	4.55	2.8	700	30.2	19.3	0.64	1.10	34.0	27.5	1.4
				900	25.5	1.62	20.0	96.2	4.61	2.6	900	31.1	21.7	0.70	1.17	35.1	26.6	1.5
	6.0	2.5	6.6	700	25.7	1.61	20.2	104.0	4.68	2.9	700	30.3	19.5	0.64	1.06	33.9	28.6	1.3
				900	26.4	1.63	20.8	97.1	4.75	2.7	900	31.2	21.8	0.70	1.13	35.0	27.7	1.4
	8.0	4.2	11.1	700	26.3	1.63	20.7	104.8	4.72	3.0	700	30.6	19.5	0.64	1.04	34.1	29.5	1.2
				900	26.9	1.64	21.3	97.7	4.81	2.8	900	31.6	21.8	0.69	1.10	35.3	28.7	1.4
60	4.0	1.2	3.1	700	27.9	1.67	22.2	107.0	4.90	3.2	700	29.5	18.9	0.64	1.21	33.6	24.4	1.7
				900	28.7	1.67	23.0	99.5	5.02	3.0	900	30.4	21.3	0.70	1.28	34.7	23.7	1.8
	6.0	2.4	6.4	700	28.9	1.69	23.1	108.2	5.01	3.3	700	29.6	19.1	0.65	1.16	33.5	25.4	1.6
				900	29.7	1.69	23.9	100.6	5.16	3.0	900	30.5	21.3	0.70	1.23	34.7	24.7	1.7
	8.0	4.0	10.7	700	29.5	1.71	23.6	109.0	5.05	3.4	700	29.9	19.1	0.64	1.14	33.8	26.2	1.5
				900	30.3	1.70	24.5	101.1	5.21	3.1	900	30.8	21.4	0.69	1.20	34.9	25.6	1.6
70	4.0	1.2	3.0	700	31.1	1.76	25.1	111.1	5.19	3.6	700	29.7	19.2	0.65	1.35	34.3	22.0	2.1
				900	32.0	1.75	26.0	102.9	5.36	3.3	900	30.6	21.6	0.71	1.42	35.4	21.5	2.2
	6.0	2.4	6.2	700	32.1	1.78	26.0	112.5	5.28	3.7	700	29.7	19.3	0.65	1.30	34.2	22.9	2.0
				900	33.1	1.76	27.1	104.1	5.50	3.4	900	30.6	21.6	0.70	1.37	35.3	22.4	2.1
	8.0	3.9	10.4	700	32.7	1.81	26.5	113.2	5.31	3.8	700	30.1	19.3	0.64	1.27	34.4	23.6	1.8
				900	33.7	1.78	27.6	104.6	5.53	3.5	900	31.0	21.7	0.70	1.34	35.5	23.1	2.0
80	4.0	1.2	2.9	700	33.6	1.84	27.3	114.4	5.36	4.0	700	28.4	19.0	0.67	1.51	33.6	18.9	2.6
				900	34.7	1.81	28.5	105.7	5.61	3.7	900	29.3	21.3	0.73	1.58	34.7	18.5	2.8
	6.0	2.3	5.9	700	34.8	1.87	28.4	116.0	5.46	4.1	700	28.6	19.1	0.67	1.45	33.5	19.7	2.5
				900	36.0	1.83	29.7	107.0	5.75	3.8	900	29.4	21.3	0.72	1.52	34.6	19.4	2.7
	8.0	3.8	10.0	700	35.3	1.89	28.9	116.7	5.47	4.3	700	28.8	19.1	0.66	1.42	33.7	20.3	2.3
				900	36.5	1.85	30.2	107.6	5.77	3.9	900	29.7	21.4	0.72	1.49	34.8	19.9	2.5
90	4.0	1.1	2.8	700	36.2	1.94	29.6	117.8	5.47	4.5	700	26.3	18.0	0.68	1.68	32.0	15.6	3.3
				900	37.4	1.89	31.0	108.5	5.80	4.2	900	27.1	20.1	0.74	1.75	33.1	15.5	3.5
	6.0	2.2	5.7	700	37.5	1.97	30.8	119.6	5.59	4.6	700	26.5	18.0	0.68	1.62	32.0	16.4	3.1
				900	38.9	1.92	32.3	110.0	5.93	4.3	900	27.3	20.1	0.74	1.68	33.0	16.2	3.3
	8.0	3.6	9.6	700	38.0	2.00	31.2	120.3	5.58	4.8	700	26.7	18.1	0.68	1.58	32.1	16.9	2.8
				900	39.5	1.94	32.8	110.6	5.95	4.4	900	27.6	20.2	0.73	1.65	33.2	16.7	3.2
100	4.0	1.1	2.7	Operation not recommended							Operation not recommended							
	6.0	2.1	5.5	Operation not recommended							700	25.3	18.0	0.71	1.83	31.5	13.8	3.8
				900	26.0	20.1	0.77	1.89	32.5	13.8	4.1	700	25.5	18.1	0.71	1.79	31.6	14.3
	8.0	3.5	9.3	Operation not recommended							900	26.3	20.2	0.77	1.85	32.6	14.2	3.9
110	4.0	1.0	2.6	Operation not recommended							Operation not recommended							
	6.0	2.0	5.3	Operation not recommended							700	21.5	16.9	0.79	2.04	28.5	10.6	4.6
				900	22.2	18.8	0.85	2.10	29.3	10.6	5.0	700	21.7	17.0	0.78	1.99	28.5	10.9
	8.0	3.4	8.9	Operation not recommended							900	22.4	18.9	0.84	2.05	29.4	10.9	4.7
120				4.0	1.0	2.5	Operation not recommended							Operation not recommended				
	6.0	2.0	5.1	Operation not recommended							700	20.8	16.3	0.78	2.30	28.7	9.1	5.5
				900	21.4	18.1	0.85	2.35	29.5	9.1	6.0	700	20.9	16.4	0.78	2.25	28.6	9.3
	8.0	3.2	8.6	Operation not recommended							900	21.7	18.2	0.84	2.30	29.5	9.4	5.7

Performance Data cont.

Model 036 - Single Speed with Variable Speed ECM or 5-Speed ECM (1250 cfm)

EWT °F	Flow Rate GPM	WPD		HEATING - EAT 70°F							COOLING - EAT 80/67 °F										
		PSI	FT/HD	Airflow CFM	HC MBtu/h	Power kW	HE MBtu/h	LAT °F	COP	HWC Mbtu/h	Airflow CFM	TC Mbtu/h	SC Mbtu/h	S/T Ratio	Power kW	HR Mbtu/h	EER	HWC Mbtu/h			
20	5.0	1.0	2.4	Operation not recommended							Operation not recommended										
	7.0	2.1	4.9	Operation not recommended							Operation not recommended										
	9.0	3.6	8.2	1050	21.0	1.83	14.8	88.5	3.36	2.7	1250	21.4	1.87	15.0	85.8	3.35	2.4	Operation not recommended			
30	5.0	1.0	2.3	Operation not recommended							Operation not recommended										
	7.0	2.1	4.7	1050	23.6	1.84	17.3	90.8	3.76	2.9	1050	30.2	19.5	0.65	1.05	33.8	28.6	---			
				1250	24.1	1.88	17.7	87.8	3.76	2.6	1250	31.0	21.9	0.70	1.14	34.9	27.2	---			
	9.0	3.5	8.0	1050	24.2	1.86	17.9	91.3	3.82	3.0	1050	30.4	19.4	0.64	1.04	34.0	29.4	---			
			1250	24.6	1.89	18.1	88.2	3.81	2.7	1250	31.5	21.8	0.69	1.10	35.3	28.7	---				
40	5.0	1.0	2.3	Operation not recommended							Operation not recommended										
	7.0	2.0	4.6	1050	27.4	1.89	20.9	94.2	4.24	3.2	1050	33.1	21.7	0.66	1.15	37.0	28.7	---			
				1250	28.0	1.92	21.5	90.8	4.28	3.0	1250	34.0	24.3	0.71	1.24	38.3	27.5	---			
	9.0	3.4	7.8	1050	28.0	1.92	21.5	94.7	4.29	3.3	1050	33.4	21.6	0.65	1.13	37.2	29.5	---			
				1250	28.6	1.94	22.0	91.2	4.33	3.0	1250	34.5	24.3	0.70	1.20	38.6	28.7	---			
50	5.0	1.0	2.2	1050	29.8	1.94	23.2	96.3	4.52	3.5	1050	35.6	23.4	0.66	1.33	40.2	26.8	1.7			
				1250	30.5	1.95	23.8	92.6	4.58	3.2	1250	36.7	26.3	0.72	1.41	41.5	26.0	1.8			
	7.0	1.9	4.5	1050	30.8	1.94	24.2	97.1	4.64	3.6	1050	35.7	23.6	0.66	1.28	40.1	27.9	1.6			
				1250	31.6	1.96	24.9	93.4	4.72	3.3	1250	36.8	26.4	0.72	1.36	41.4	27.0	1.7			
	9.0	3.3	7.5	1050	31.5	1.97	24.7	97.7	4.68	3.7	1050	36.1	23.6	0.65	1.25	40.4	28.8	1.4			
				1250	32.2	1.98	25.5	93.9	4.78	3.4	1250	37.2	26.4	0.71	1.33	41.8	28.0	1.6			
60	5.0	0.9	2.1	1050	33.4	1.99	26.6	99.4	4.92	3.9	1050	35.4	24.0	0.68	1.45	40.3	24.4	2.0			
				1250	34.3	1.99	27.5	95.4	5.04	3.6	1250	36.4	26.9	0.74	1.54	41.7	23.7	2.1			
	7.0	1.9	4.3	1050	34.5	2.01	27.6	100.4	5.03	4.0	1050	35.4	24.1	0.68	1.40	40.2	25.4	1.9			
				1250	35.5	2.01	28.6	96.3	5.18	3.7	1250	36.5	27.0	0.74	1.48	41.6	24.7	2.0			
	9.0	3.1	7.3	1050	35.2	2.04	28.2	101.0	5.06	4.2	1050	35.8	24.1	0.67	1.37	40.5	26.2	1.7			
			1250	36.2	2.03	29.2	96.8	5.23	3.8	1250	36.9	27.0	0.73	1.45	41.9	25.6	1.9				
70	5.0	0.9	2.1	1050	37.1	2.05	30.1	102.8	5.31	4.4	1050	35.9	24.9	0.69	1.61	41.3	22.3	2.5			
				1250	38.2	2.04	31.3	98.3	5.48	4.1	1250	36.9	28.0	0.76	1.70	42.7	21.8	2.6			
	7.0	1.8	4.2	1050	38.4	2.09	31.3	103.9	5.40	4.5	1050	36.0	25.0	0.70	1.55	41.2	23.2	2.3			
				1250	39.6	2.06	32.6	99.3	5.63	4.2	1250	37.0	28.0	0.76	1.63	42.6	22.7	2.5			
	9.0	3.0	7.0	1050	39.1	2.11	31.9	104.5	5.43	4.7	1050	36.3	25.0	0.69	1.52	41.5	24.0	2.2			
			1250	40.3	2.09	33.2	99.8	5.66	4.3	1250	37.4	28.1	0.75	1.60	42.9	23.4	2.4				
80	5.0	0.9	2.0	1050	40.1	2.11	32.9	105.4	5.57	4.9	1050	35.0	24.8	0.71	1.78	41.0	19.6	3.1			
				1250	41.4	2.08	34.3	100.7	5.83	4.6	1250	36.0	27.8	0.77	1.87	42.4	19.3	3.3			
	7.0	1.7	4.0	1050	41.6	2.15	34.3	106.7	5.68	5.1	1050	35.1	24.9	0.71	1.72	41.0	20.4	2.9			
				1250	43.0	2.11	35.8	101.8	5.97	4.7	1250	36.2	27.8	0.77	1.80	42.3	20.2	3.1			
	9.0	2.9	6.8	1050	42.2	2.18	34.8	107.2	5.69	5.2	1050	35.5	24.9	0.70	1.68	41.2	21.1	2.7			
			1250	43.7	2.13	36.4	102.3	6.00	4.8	1250	36.6	27.9	0.76	1.76	42.6	20.7	3.0				
90	5.0	0.8	1.9	1050	43.3	2.18	35.9	108.2	5.82	5.5	1050	32.8	24.2	0.74	1.97	39.5	16.6	3.9			
				1250	44.9	2.13	37.6	103.2	6.16	5.1	1250	33.8	27.0	0.80	2.05	40.8	16.5	4.1			
	7.0	1.7	3.9	1050	45.0	2.22	37.4	109.6	5.95	5.7	1050	33.0	24.2	0.73	1.90	39.5	17.4	3.6			
				1250	46.6	2.17	39.2	104.5	6.31	5.3	1250	34.0	27.0	0.79	1.97	40.7	17.3	3.9			
	9.0	2.8	6.6	1050	45.5	2.25	37.9	110.2	5.93	5.9	1050	33.3	24.3	0.73	1.85	39.6	17.9	3.4			
			1250	47.3	2.19	39.8	105.0	6.32	5.4	1250	34.3	27.1	0.79	1.94	40.9	17.7	3.7				
100	5.0	0.8	1.8	Operation not recommended							Operation not recommended										
	7.0	1.6	3.8	Operation not recommended							Operation not recommended										
	9.0	2.7	6.3	Operation not recommended							Operation not recommended										
				1050	32.1	24.0	0.75	2.12	39.3	15.1	4.5	1250	33.1	26.8	0.81	2.20	40.6	15.0	4.8		
110	5.0	0.8	1.8	Operation not recommended							Operation not recommended										
	7.0	1.6	3.6	Operation not recommended							Operation not recommended										
	9.0	2.6	6.1	Operation not recommended							Operation not recommended										
				1050	28.9	22.3	0.77	2.35	36.9	12.3	5.4	1250	29.8	24.9	0.84	2.42	38.0	12.3	5.9		
				1050	29.1	22.4	0.77	2.30	37.0	12.7	5.0	1250	30.1	25.0	0.83	2.37	38.2	12.7	5.6		
120	5.0	0.7	1.7	Operation not recommended							Operation not recommended										
	7.0	1.5	3.5	Operation not recommended							Operation not recommended										
	9.0	2.5	5.8	Operation not recommended							Operation not recommended										
				1050	27.1	22.0	0.81	2.63	36.1	10.3	6.5	1250	27.9	24.5	0.88	2.70	37.1	10.4	7.1		
			1050	27.3	22.2	0.81	2.57	36.1	10.6	6.1	1250	28.2	24.6	0.87	2.63	37.2	10.7	6.7			

Performance Data cont.

Model 042 - Single Speed with Variable Speed ECM or 5-Speed ECM (1350 cfm)

EWT °F	Flow Rate GPM	WPD		HEATING - EAT 70°F							COOLING - EAT 80/67 °F							
		PSI	FT/HD	Airflow CFM	HC MBtu/h	Power kW	HE MBtu/h	LAT °F	COP	HWC Mbtu/h	Airflow CFM	TC Mbtu/h	SC Mbtu/h	S/T Ratio	Power kW	HR Mbtu/h	EER	HWC Mbtu/h
20	5.0	0.8	1.9	Operation not recommended							Operation not recommended							
	8.0	2.3	5.3	Operation not recommended							Operation not recommended							
	11.0	4.4	10.3	1150	24.0	2.12	16.8	89.3	3.32	4.1	Operation not recommended							
1350				24.3	2.10	17.1	86.7	3.39	3.7	Operation not recommended								
30	5.0	0.8	1.8	Operation not recommended							Operation not recommended							
	8.0	2.2	5.1	1150	27.9	2.16	20.6	92.5	3.80	4.3	1150	40.2	24.5	0.61	1.34	44.8	29.9	---
				1350	28.3	2.14	21.0	89.4	3.87	3.9	1350	42.1	27.5	0.65	1.42	46.9	29.6	---
	11.0	4.3	10.0	1150	28.3	2.16	21.0	92.8	3.85	4.4	1150	40.6	24.5	0.60	1.31	45.0	31.1	---
				1350	28.7	2.14	21.4	89.7	3.93	4.0	1350	42.5	27.5	0.65	1.38	47.2	30.8	---
40	5.0	0.8	1.8	Operation not recommended							Operation not recommended							
	8.0	2.1	4.9	1150	31.8	2.24	24.1	95.6	4.15	4.7	1150	41.9	26.2	0.62	1.43	46.8	29.3	---
				1350	32.3	2.21	24.7	92.1	4.28	4.3	1350	43.8	29.4	0.67	1.51	48.9	29.0	---
	11.0	4.2	9.7	1150	32.4	2.25	24.7	96.1	4.21	4.9	1150	42.3	26.2	0.62	1.39	47.1	30.5	---
				1350	32.9	2.21	25.3	92.5	4.35	4.4	1350	44.2	29.4	0.66	1.47	49.2	30.1	---
50	5.0	0.7	1.7	1150	34.2	2.26	26.5	97.5	4.44	5.1	1150	42.6	27.0	0.63	1.62	48.1	26.3	2.5
				1350	34.8	2.21	27.2	93.8	4.61	4.7	1350	44.4	30.4	0.68	1.71	50.2	26.0	2.6
	8.0	2.1	4.8	1150	35.6	2.31	27.7	98.7	4.52	5.3	1150	43.1	27.3	0.63	1.55	48.3	27.9	2.3
				1350	36.2	2.26	28.5	94.8	4.71	4.8	1350	44.8	30.7	0.68	1.63	50.4	27.6	2.5
	11.0	4.1	9.4	1150	36.3	2.32	28.4	99.3	4.58	5.4	1150	43.5	27.3	0.63	1.50	48.6	29.0	2.1
				1350	37.0	2.27	29.3	95.4	4.78	5.0	1350	45.3	30.7	0.68	1.58	50.7	28.7	2.4
60	5.0	0.7	1.7	1150	37.5	2.32	29.6	100.2	4.73	5.7	1150	42.5	27.7	0.65	1.78	48.5	23.8	3.0
				1350	38.3	2.26	30.5	96.2	4.96	5.3	1350	44.1	31.1	0.71	1.87	50.5	23.6	3.2
	8.0	2.0	4.6	1150	39.2	2.39	31.0	101.6	4.80	5.9	1150	43.0	28.0	0.65	1.70	48.8	25.4	2.8
				1350	40.0	2.32	32.1	97.4	5.06	5.4	1350	44.7	31.4	0.70	1.78	50.8	25.1	3.0
	11.0	3.9	9.1	1150	40.1	2.41	31.9	102.3	4.87	6.1	1150	43.4	28.0	0.64	1.65	49.1	26.4	2.6
				1350	41.0	2.34	33.0	98.1	5.14	5.6	1350	45.1	31.4	0.70	1.73	51.0	26.1	2.9
70	5.0	0.7	1.6	1150	40.7	2.40	32.5	102.8	4.97	6.4	1150	42.6	28.6	0.67	1.97	49.4	21.6	3.8
				1350	41.6	2.32	33.7	98.6	5.26	6.0	1350	44.2	32.1	0.73	2.06	51.2	21.4	4.0
	8.0	1.9	4.5	1150	42.7	2.48	34.2	104.4	5.04	6.6	1150	43.3	28.9	0.67	1.87	49.7	23.1	3.5
				1350	43.7	2.39	35.5	100.0	5.36	6.1	1350	44.9	32.5	0.72	1.96	51.5	22.9	3.8
	11.0	3.8	8.8	1150	43.8	2.51	35.2	105.2	5.11	6.8	1150	43.7	28.9	0.66	1.82	49.9	24.1	3.3
				1350	44.9	2.42	36.6	100.8	5.45	6.3	1350	45.3	32.5	0.72	1.90	51.8	23.8	3.6
80	5.0	0.7	1.6	1150	43.7	2.44	35.4	105.2	5.26	7.2	1150	41.0	27.9	0.68	2.19	48.5	18.7	4.8
				1350	44.9	2.34	36.9	100.8	5.63	6.7	1350	42.4	31.4	0.74	2.29	50.2	18.5	5.1
	8.0	1.9	4.3	1150	46.0	2.54	37.4	107.0	5.32	7.5	1150	41.8	28.2	0.68	2.08	48.9	20.1	4.5
				1350	47.3	2.42	39.0	102.4	5.72	6.9	1350	43.2	31.7	0.73	2.17	50.6	19.9	4.8
	11.0	3.7	8.5	1150	47.3	2.57	38.6	108.1	5.39	7.7	1150	42.2	28.2	0.67	2.02	49.1	20.9	4.1
				1350	48.7	2.46	40.3	103.4	5.82	7.1	1350	43.6	31.7	0.73	2.11	50.8	20.7	4.6
90	5.0	0.7	1.5	1150	46.7	2.48	38.2	107.6	5.51	8.1	1150	38.9	27.1	0.70	2.45	47.2	15.9	6.0
				1350	48.0	2.37	40.0	102.9	5.95	7.5	1350	40.1	30.5	0.76	2.55	48.8	15.7	6.4
	8.0	1.8	4.2	1150	49.2	2.60	40.4	109.6	5.55	8.4	1150	39.7	27.4	0.69	2.31	47.6	17.1	5.6
				1350	50.8	2.47	42.4	104.8	6.03	7.8	1350	40.9	30.8	0.75	2.41	49.1	17.0	6.1
	11.0	3.5	8.2	1150	50.8	2.64	41.8	110.9	5.63	8.6	1150	40.1	27.4	0.68	2.25	47.7	17.8	5.2
				1350	52.4	2.51	43.9	106.0	6.14	8.0	1350	41.3	30.8	0.75	2.34	49.3	17.6	5.8
100	5.0	0.6	1.5	Operation not recommended							Operation not recommended							
	8.0	1.7	4.0	Operation not recommended							1150	38.2	26.9	0.70	2.58	47.0	14.8	6.9
				1350	39.2	30.2	0.77	2.68	48.4	14.6	7.5							
	11.0	3.4	7.9	Operation not recommended							1150	38.5	26.9	0.70	2.50	47.1	15.4	6.4
1350				39.6	30.2	0.76	2.60	48.5	15.2	7.2								
110	5.0	0.6	1.4	Operation not recommended							Operation not recommended							
	8.0	1.7	3.9	Operation not recommended							1150	34.8	24.9	0.71	2.88	44.6	12.1	8.5
				1350	35.7	27.9	0.78	2.98	45.9	12.0	9.2							
	11.0	3.3	7.6	Operation not recommended							1150	35.1	24.9	0.71	2.79	44.7	12.6	7.9
1350				36.0	27.9	0.77	2.89	45.9	12.5	8.8								
120	5.0	0.6	1.3	Operation not recommended							Operation not recommended							
	8.0	1.6	3.7	Operation not recommended							1150	32.8	24.6	0.75	3.20	43.7	10.2	10.3
				1350	33.5	27.6	0.82	3.31	44.8	10.1	11.1							
	11.0	3.2	7.3	Operation not recommended							1150	33.1	24.6	0.74	3.11	43.7	10.7	9.5
1350				33.9	27.6	0.81	3.21	44.8	10.6	10.6								

Performance Data cont.

Model 048 - Single Speed with Variable Speed ECM or 5-Speed ECM (1500 cfm)

EWT °F	Flow Rate GPM	WPD		HEATING - EAT 70°F							COOLING - EAT 80/67 °F							
		PSI	FT/HD	Airflow CFM	HC MBtu/h	Power kW	HE MBtu/h	LAT °F	COP	HWC Mbtu/h	Airflow CFM	TC Mbtu/h	SC Mbtu/h	S/T Ratio	Power kW	HR Mbtu/h	EER	HWC Mbtu/h
20	6.0	1.1	2.6	Operation not recommended							Operation not recommended							
	9.0	2.3	5.4	Operation not recommended							Operation not recommended							
	12.0	4.0	9.2	1300	31.6	2.84	21.9	92.5	3.26	5.3	Operation not recommended							
1500				32.0	2.82	22.4	89.7	3.33	4.8	Operation not recommended								
30	6.0	1.1	2.5	Operation not recommended							Operation not recommended							
	9.0	2.3	5.3	1300	36.3	2.92	26.3	95.8	3.64	5.6	1300	48.2	29.6	0.61	1.58	53.6	30.5	---
				1500	36.7	2.90	26.8	92.6	3.71	5.2	1500	50.5	33.3	0.66	1.67	56.2	30.2	---
	12.0	3.9	9.0	1300	36.8	2.93	26.8	96.2	3.68	5.8	1300	48.7	29.6	0.61	1.53	53.9	31.8	---
				1500	37.2	2.90	27.3	93.0	3.76	5.3	1500	51.0	33.3	0.65	1.62	56.5	31.4	---
40	6.0	1.1	2.5	Operation not recommended							Operation not recommended							
	9.0	2.2	5.1	1300	41.7	3.05	31.3	99.7	4.00	6.2	1300	50.1	31.2	0.62	1.74	56.0	28.9	---
				1500	42.2	3.00	32.0	96.1	4.13	5.7	1500	52.3	35.1	0.67	1.83	58.6	28.6	---
	12.0	3.8	8.7	1300	42.4	3.06	31.9	100.2	4.06	6.4	1300	50.6	31.2	0.62	1.68	56.4	30.0	---
				1500	43.0	3.01	32.7	96.5	4.19	5.8	1500	52.9	35.1	0.66	1.78	58.9	29.7	---
50	6.0	1.0	2.4	1300	44.7	3.09	34.1	101.8	4.24	6.7	1300	51.2	32.5	0.63	2.02	58.1	25.3	2.9
				1500	45.4	3.02	35.1	98.0	4.40	6.2	1500	53.3	36.5	0.68	2.13	60.6	25.1	3.1
	9.0	2.1	4.9	1300	46.5	3.16	35.7	103.1	4.32	6.9	1300	51.7	32.8	0.63	1.93	58.3	26.8	2.7
				1500	47.3	3.08	36.7	99.2	4.49	6.4	1500	53.9	36.8	0.68	2.03	60.8	26.6	2.9
	12.0	3.7	8.4	1300	47.4	3.18	36.6	103.8	4.37	7.2	1300	52.2	32.8	0.63	1.87	58.6	27.9	2.5
				1500	48.2	3.10	37.7	99.8	4.56	6.5	1500	54.4	36.8	0.68	1.97	61.1	27.6	2.8
60	6.0	1.0	2.3	1300	49.1	3.18	38.2	105.0	4.52	7.6	1300	50.0	32.1	0.64	2.24	57.6	22.3	3.5
				1500	50.0	3.10	39.5	100.9	4.74	7.0	1500	51.9	36.0	0.69	2.35	59.9	22.1	3.7
	9.0	2.1	4.8	1300	51.3	3.28	40.1	106.5	4.59	7.8	1300	50.6	32.4	0.64	2.13	57.9	23.7	3.3
				1500	52.3	3.18	41.5	102.3	4.83	7.2	1500	52.6	36.4	0.69	2.24	60.2	23.5	3.6
	12.0	3.5	8.2	1300	52.5	3.31	41.2	107.4	4.65	8.0	1300	51.1	32.4	0.63	2.07	58.2	24.7	3.0
				1500	53.6	3.20	42.7	103.1	4.91	7.4	1500	53.1	36.4	0.69	2.17	60.5	24.4	3.4
70	6.0	1.0	2.2	1300	53.6	3.29	42.4	108.2	4.78	8.5	1300	49.7	32.4	0.65	2.51	58.3	19.8	4.4
				1500	54.7	3.17	43.9	103.8	5.05	7.9	1500	51.5	36.5	0.71	2.63	60.5	19.6	4.7
	9.0	2.0	4.6	1300	56.1	3.40	44.5	110.0	4.84	8.8	1300	50.5	32.8	0.65	2.38	58.6	21.2	4.1
				1500	57.4	3.27	46.3	105.5	5.14	8.1	1500	52.3	36.8	0.70	2.50	60.9	21.0	4.5
	12.0	3.4	7.9	1300	57.6	3.44	45.8	111.0	4.91	9.0	1300	51.0	32.8	0.64	2.31	58.9	22.0	3.8
				1500	59.0	3.31	47.7	106.4	5.22	8.3	1500	52.9	36.8	0.70	2.42	61.1	21.8	4.2
80	6.0	0.9	2.1	1300	57.1	3.37	45.6	110.7	4.97	9.6	1300	47.7	31.7	0.67	2.81	57.3	17.0	5.6
				1500	58.6	3.23	47.5	106.2	5.32	8.8	1500	49.3	35.6	0.72	2.94	59.3	16.8	5.9
	9.0	1.9	4.5	1300	60.1	3.50	48.1	112.8	5.03	9.8	1300	48.5	32.0	0.66	2.66	57.6	18.2	5.2
				1500	61.7	3.35	50.3	108.1	5.40	9.1	1500	50.2	36.0	0.72	2.78	59.7	18.0	5.6
	12.0	3.3	7.6	1300	61.8	3.55	49.7	114.0	5.10	10.1	1300	49.0	32.0	0.65	2.59	57.8	19.0	4.8
				1500	63.5	3.39	51.9	109.2	5.49	9.4	1500	50.7	36.0	0.71	2.70	59.9	18.8	5.4
90	6.0	0.9	2.1	1300	60.7	3.45	48.9	113.2	5.16	10.7	1300	44.5	30.3	0.68	3.14	55.2	14.2	7.0
				1500	62.4	3.29	51.2	108.5	5.56	9.9	1500	45.9	34.0	0.74	3.27	57.0	14.0	7.4
	9.0	1.9	4.3	1300	64.1	3.61	51.7	115.6	5.20	11.1	1300	45.4	30.6	0.67	2.97	55.5	15.3	6.5
				1500	66.0	3.43	54.3	110.7	5.64	10.2	1500	46.8	34.3	0.73	3.09	57.4	15.1	7.1
	12.0	3.2	7.4	1300	66.1	3.67	53.5	117.0	5.27	11.4	1300	45.9	30.6	0.67	2.88	55.7	15.9	6.1
				1500	68.1	3.48	56.2	112.0	5.74	10.6	1500	47.3	34.3	0.73	3.00	57.5	15.7	6.7
100	6.0	0.9	2.0	Operation not recommended							Operation not recommended							
	9.0	1.8	4.2	Operation not recommended							1300	43.9	30.1	0.69	3.33	55.2	13.2	8.1
				1500	45.1	33.9	0.75	3.46	56.9	13.0	8.8							
	12.0	3.1	7.1	Operation not recommended							1300	44.3	30.1	0.68	3.23	55.3	13.7	7.5
1500				45.6	33.9	0.74	3.36	57.0	13.6	8.4								
110	6.0	0.8	1.9	Operation not recommended							Operation not recommended							
	9.0	1.7	4.0	Operation not recommended							1300	39.7	28.0	0.71	3.71	52.3	10.7	9.9
				1500	40.7	31.4	0.77	3.84	53.8	10.6	10.8							
	12.0	3.0	6.8	Operation not recommended							1300	40.1	28.0	0.70	3.60	52.3	11.1	9.2
1500				41.1	31.4	0.77	3.73	53.8	11.0	10.2								
120	6.0	0.8	1.8	Operation not recommended							Operation not recommended							
	9.0	1.7	3.8	Operation not recommended							1300	37.6	27.4	0.73	4.13	51.7	9.1	12.0
				1500	38.4	30.8	0.80	4.27	53.0	9.0	13.0							
	12.0	2.8	6.6	Operation not recommended							1300	37.9	27.4	0.72	4.01	51.6	9.5	11.1
1500				38.8	30.8	0.79	4.15	53.0	9.4	12.4								

Performance Data cont.

Model 060 - Single Speed with Variable Speed ECM or 5-Speed ECM (2000 cfm)

EWT °F	Flow Rate GPM	WPD		HEATING - EAT 70°F							COOLING - EAT 80/67 °F							
		PSI	FT/HD	Airflow CFM	HC MBtu/h	Power kW	HE MBtu/h	LAT °F	COP	HWC Mbtu/h	Airflow CFM	TC Mbtu/h	SC Mbtu/h	S/T Ratio	Power kW	HR Mbtu/h	EER	HWC Mbtu/h
20	9.0	2.5	5.7	Operation not recommended							Operation not recommended							
	12.0	4.0	9.2	Operation not recommended							Operation not recommended							
	15.0	5.9	13.5	1500	38.6	3.70	26.0	93.8	3.06	6.5	Operation not recommended							
2000				39.4	3.77	26.5	88.2	3.06	5.8	Operation not recommended								
30	9.0	2.4	5.5	Operation not recommended							Operation not recommended							
	12.0	3.9	8.9	1500	43.5	3.70	30.9	96.9	3.45	6.8	1500	73.6	46.9	0.64	2.16	81.0	34.1	---
				2000	44.4	3.77	31.5	90.5	3.45	6.2	2000	71.2	48.3	0.68	2.61	80.2	27.3	---
	15.0	5.7	13.1	1500	44.9	3.80	31.9	97.7	3.46	7.0	1500	74.3	47.0	0.63	2.16	81.7	34.4	---
				2000	45.8	3.86	32.6	91.2	3.47	6.4	2000	72.4	47.8	0.66	2.44	80.8	29.6	---
40	9.0	2.3	5.3	Operation not recommended							Operation not recommended							
	12.0	3.7	8.7	1500	51.3	3.86	38.2	101.7	3.90	7.5	1500	71.9	47.4	0.66	2.40	80.1	30.0	---
				2000	52.5	3.94	39.1	94.3	3.91	6.9	2000	71.3	49.5	0.69	2.81	80.9	25.4	---
	15.0	5.5	12.7	1500	52.8	3.94	39.3	102.6	3.92	7.8	1500	72.6	47.6	0.66	2.39	80.8	30.4	---
				2000	53.8	4.01	40.1	94.9	3.93	7.1	2000	72.1	49.3	0.68	2.65	81.2	27.2	---
50	9.0	2.2	5.2	1500	57.3	4.00	43.6	105.4	4.19	8.1	1500	72.2	48.4	0.67	2.81	81.8	25.7	3.9
				2000	57.9	4.05	44.1	96.8	4.19	7.5	2000	72.4	50.2	0.69	3.15	83.1	23.0	4.1
	12.0	3.6	8.4	1500	57.9	3.99	44.3	105.7	4.25	8.4	1500	72.3	48.5	0.67	2.71	81.6	26.7	3.6
				2000	59.4	4.09	45.5	97.5	4.26	7.7	2000	72.4	50.7	0.70	3.09	82.9	23.5	3.9
	15.0	5.3	12.3	1500	59.4	4.08	45.5	106.6	4.27	8.6	1500	73.0	48.7	0.67	2.70	82.2	27.1	3.4
				2000	60.5	4.13	46.4	98.0	4.29	7.9	2000	73.1	50.7	0.69	2.94	83.2	24.9	3.7
60	9.0	2.2	5.0	1500	63.3	4.14	49.2	109.1	4.48	9.1	1500	68.5	46.2	0.68	3.04	78.9	22.5	4.7
				2000	64.4	4.17	50.1	99.8	4.52	8.4	2000	70.0	49.1	0.70	3.33	81.4	21.0	5.0
	12.0	3.5	8.1	1500	64.9	4.16	50.7	110.0	4.57	9.4	1500	68.7	46.4	0.68	2.93	78.7	23.4	4.4
				2000	65.8	4.21	51.4	100.5	4.57	8.7	2000	70.4	49.3	0.70	3.24	81.4	21.7	4.8
	15.0	5.2	11.9	1500	66.3	4.23	51.9	110.9	4.59	9.7	1500	69.4	46.7	0.67	2.91	79.3	23.9	4.1
				2000	67.7	4.28	53.1	101.3	4.63	8.9	2000	70.8	49.6	0.70	3.12	81.4	22.7	4.6
70	9.0	2.1	4.9	1500	69.5	4.29	54.9	112.9	4.75	10.3	1500	65.9	45.2	0.69	3.42	77.5	19.3	5.9
				2000	71.0	4.31	56.3	102.9	4.83	9.5	2000	68.8	49.1	0.71	3.68	81.3	18.7	6.3
	12.0	3.4	7.9	1500	72.0	4.33	57.2	114.5	4.87	10.6	1500	66.2	45.5	0.69	3.29	77.4	20.1	5.5
				2000	72.4	4.35	57.5	103.5	4.87	9.8	2000	69.5	49.1	0.71	3.54	81.6	19.6	6.0
	15.0	5.0	11.6	1500	73.4	4.40	58.4	115.3	4.89	10.9	1500	66.8	45.8	0.69	3.25	77.9	20.6	5.1
				2000	75.1	4.44	59.9	104.7	4.95	10.0	2000	69.5	49.6	0.71	3.44	81.2	20.2	5.7
80	9.0	2.0	4.7	1500	74.3	4.41	59.3	115.9	4.94	11.5	1500	64.1	44.6	0.70	3.81	77.0	16.8	7.5
				2000	75.7	4.41	60.6	105.0	5.03	10.7	2000	65.7	47.7	0.73	4.06	79.6	16.2	8.0
	12.0	3.3	7.6	1500	77.7	4.48	62.4	117.9	5.08	11.9	1500	64.4	45.0	0.70	3.66	76.9	17.6	7.0
				2000	78.3	4.44	63.2	106.3	5.18	11.0	2000	66.4	47.7	0.72	3.87	79.6	17.2	7.6
	15.0	4.8	11.2	1500	78.9	4.54	63.4	118.7	5.10	12.2	1500	65.1	45.4	0.70	3.60	77.4	18.1	6.5
				2000	80.5	4.57	64.9	107.3	5.16	11.3	2000	66.7	48.2	0.72	3.76	79.6	17.8	7.2
90	9.0	2.0	4.5	1500	79.3	4.54	63.8	119.0	5.12	13.0	1500	60.9	43.2	0.71	4.20	75.2	14.5	9.4
				2000	80.6	4.53	65.1	107.3	5.21	12.0	2000	61.3	45.5	0.74	4.45	76.5	13.8	10.0
	12.0	3.2	7.3	1500	83.5	4.65	67.7	121.6	5.27	13.4	1500	61.3	43.7	0.71	4.03	75.1	15.2	8.8
				2000	84.5	4.53	69.1	109.1	5.47	12.4	2000	61.9	45.5	0.73	4.20	76.3	14.7	9.5
	15.0	4.7	10.8	1500	84.7	4.69	68.6	122.3	5.29	13.8	1500	61.9	44.1	0.71	3.96	75.4	15.7	8.2
				2000	86.2	4.72	70.0	109.9	5.35	12.8	2000	62.6	46.0	0.73	4.08	76.5	15.3	9.1
100	9.0	1.9	4.4	Operation not recommended							Operation not recommended							
	12.0	3.1	7.1	Operation not recommended							1500	58.8	42.9	0.73	4.59	74.5	12.8	10.9
				2000	59.4	44.7	0.75	4.70	75.5	12.6	11.8							
	15.0	4.5	10.4	Operation not recommended							1500	59.4	43.4	0.73	4.49	74.8	13.2	10.1
2000				60.0	45.2	0.75	4.58	75.7	13.1	11.2								
110	9.0	1.8	4.2	Operation not recommended							Operation not recommended							
	12.0	2.9	6.8	Operation not recommended							1500	53.8	39.9	0.74	5.08	71.2	10.6	13.4
				2000	54.4	41.5	0.76	5.14	71.9	10.6	14.5							
	15.0	4.3	10.0	Operation not recommended							1500	54.4	40.4	0.74	4.96	71.3	11.0	12.4
2000				54.9	42.1	0.77	5.01	72.0	11.0	13.8								
120	9.0	1.7	4.0	Operation not recommended							Operation not recommended							
	12.0	2.8	6.5	Operation not recommended							1500	51.8	40.5	0.78	5.78	71.5	9.0	16.1
				2000	50.8	41.2	0.81	5.80	70.6	8.8	17.5							
	15.0	4.2	9.6	Operation not recommended							1500	52.3	41.1	0.78	5.62	71.5	9.3	15.0
2000				51.7	41.7	0.81	5.63	70.9	9.2	16.7								

Performance Data cont.

Model 070 - Single Speed with Variable Speed ECM or 5-Speed ECM (2200 cfm)

EWT °F	Flow Rate GPM	WPD		HEATING - EAT 70°F							COOLING - EAT 80/67 °F							
		PSI	FT/HD	Airflow CFM	HC MBtu/h	Power kW	HE MBtu/h	LAT °F	COP	HWC Mbtu/h	Airflow CFM	TC Mbtu/h	SC Mbtu/h	S/T Ratio	Power kW	HR Mbtu/h	EER	HWC Mbtu/h
20	12.0	3.0	7.0	Operation not recommended							Operation not recommended							
	15.0	4.4	10.2	Operation not recommended							Operation not recommended							
	18.0	6.0	13.9	1700	45.6	4.45	30.4	94.8	3.00	7.7	Operation not recommended							
				2200	46.6	4.54	31.2	89.6	3.01	6.9	Operation not recommended							
30	12.0	3.0	6.8	Operation not recommended							Operation not recommended							
	15.0	4.3	9.9	1700	52.5	4.55	37.0	98.6	3.38	8.1	1700	69.3	43.4	0.63	2.39	77.5	29.0	---
				2200	53.8	4.65	37.9	92.6	3.39	7.4	2200	73.9	49.6	0.67	2.79	83.4	26.5	---
	18.0	5.8	13.5	1700	52.7	4.57	37.1	98.7	3.38	8.4	1700	69.7	42.9	0.62	2.38	77.8	29.3	---
				2200	54.0	4.66	38.1	92.7	3.39	7.6	2200	74.3	49.0	0.66	2.78	83.8	26.7	---
	40	12.0	2.9	6.6	Operation not recommended							Operation not recommended						
15.0		4.1	9.6	1700	61.3	4.75	45.1	103.4	3.78	8.9	1700	71.7	46.1	0.64	2.63	80.6	27.3	---
				2200	62.8	4.80	46.4	96.4	3.83	8.2	2200	76.1	52.7	0.69	3.03	86.4	25.1	---
18.0		5.7	13.1	1700	61.7	4.77	45.4	103.6	3.79	9.2	1700	72.2	45.9	0.64	2.61	81.1	27.7	---
				2200	63.2	4.82	46.7	96.6	3.84	8.4	2200	76.6	52.5	0.68	3.01	86.9	25.5	---
50		12.0	2.8	6.4	1700	67.6	4.89	50.9	106.8	4.05	9.7	1700	75.1	48.4	0.64	3.01	85.4	24.9
	2200				69.2	4.91	52.4	99.1	4.13	8.9	2200	79.4	55.4	0.70	3.43	91.1	23.2	4.5
	15.0	4.0	9.3	1700	68.9	4.94	52.1	107.5	4.09	10.0	1700	75.5	48.7	0.64	2.92	85.5	25.8	4.0
				2200	70.6	4.95	53.7	99.7	4.18	9.2	2200	79.8	55.7	0.70	3.33	91.2	24.0	4.3
	18.0	5.5	12.7	1700	69.5	4.97	52.6	107.9	4.10	10.3	1700	76.3	48.9	0.64	2.89	86.1	26.4	3.7
				2200	71.3	4.98	54.3	100.0	4.20	9.4	2200	80.6	55.9	0.69	3.29	91.9	24.5	4.1
60	12.0	2.7	6.2	1700	74.9	5.09	57.5	110.8	4.31	10.8	1700	72.3	46.9	0.65	3.31	83.5	21.8	5.2
				2200	76.8	5.06	59.5	102.3	4.45	10.0	2200	76.1	53.6	0.70	3.72	88.8	20.4	5.5
	15.0	3.9	9.0	1700	77.1	5.16	59.5	112.0	4.38	11.2	1700	72.6	47.0	0.65	3.22	83.5	22.6	4.8
				2200	79.1	5.12	61.6	103.3	4.53	10.3	2200	76.4	53.8	0.70	3.62	88.8	21.1	5.2
	18.0	5.3	12.3	1700	78.0	5.20	60.2	112.5	4.39	11.5	1700	73.5	47.6	0.65	3.17	84.3	23.2	4.5
				2200	80.0	5.15	62.4	103.7	4.55	10.6	2200	77.4	54.5	0.70	3.57	89.5	21.7	5.0
70	12.0	2.6	6.0	1700	82.6	5.30	64.5	115.0	4.57	12.2	1700	72.0	47.5	0.66	3.69	84.6	19.5	6.5
				2200	84.8	5.22	66.9	105.7	4.76	11.3	2200	75.5	54.4	0.72	4.11	89.5	18.4	6.9
	15.0	3.8	8.7	1700	85.6	5.40	67.2	116.6	4.65	12.6	1700	72.3	47.6	0.66	3.59	84.5	20.2	6.1
				2200	87.9	5.30	69.8	107.0	4.86	11.6	2200	75.8	54.5	0.72	3.99	89.4	19.0	6.6
	18.0	5.1	11.9	1700	86.8	5.44	68.2	117.3	4.67	13.0	1700	73.4	48.7	0.66	3.53	85.4	20.8	5.6
				2200	89.1	5.34	70.9	107.5	4.89	11.9	2200	76.9	55.7	0.72	3.93	90.3	19.6	6.3
80	12.0	2.5	5.8	1700	88.2	5.50	69.4	118.0	4.70	13.7	1700	69.1	45.5	0.66	4.12	83.1	16.8	8.2
				2200	90.7	5.37	72.3	108.2	4.95	12.7	2200	72.1	52.1	0.72	4.53	87.6	15.9	8.7
	15.0	3.6	8.4	1700	92.2	5.62	73.0	120.2	4.81	14.1	1700	69.3	45.5	0.66	4.00	82.9	17.3	7.7
				2200	94.8	5.47	76.2	109.9	5.08	13.1	2200	72.4	52.1	0.72	4.40	87.4	16.4	8.3
	18.0	5.0	11.5	1700	93.6	5.68	74.3	121.0	4.83	14.6	1700	70.5	46.9	0.67	3.92	83.9	18.0	7.1
				2200	96.5	5.52	77.6	110.6	5.12	13.5	2200	73.6	53.7	0.73	4.31	88.3	17.1	7.9
90	12.0	2.4	5.6	1700	94.2	5.72	74.7	121.3	4.83	15.4	1700	63.4	42.2	0.67	4.57	79.0	13.9	10.3
				2200	97.0	5.53	78.1	110.8	5.14	14.3	2200	66.0	48.4	0.73	4.98	83.0	13.3	10.9
	15.0	3.5	8.1	1700	99.2	5.87	79.2	124.1	4.96	15.9	1700	63.6	42.1	0.66	4.45	78.8	14.3	9.6
				2200	102.2	5.66	82.9	113.0	5.29	14.7	2200	66.2	48.3	0.73	4.84	82.7	13.7	10.4
	18.0	4.8	11.1	1700	100.9	5.93	80.7	125.0	4.99	16.4	1700	64.9	43.8	0.68	4.35	79.7	14.9	8.9
				2200	104.2	5.71	84.8	113.9	5.35	15.2	2200	67.5	50.3	0.74	4.73	83.6	14.3	9.9
100	12.0	2.3	5.4	Operation not recommended							Operation not recommended							
	15.0	3.4	7.8	1700	61.7	41.6	0.67	5.01	78.9	12.3	12.0	Operation not recommended						
				2200	64.0	47.7	0.75	5.39	82.4	11.9	13.0	Operation not recommended						
	18.0	4.6	10.7	1700	63.1	43.7	0.69	4.88	79.8	12.9	11.1	Operation not recommended						
2200				65.4	50.1	0.77	5.24	83.3	12.5	12.3	Operation not recommended							
110	12.0	2.2	5.2	Operation not recommended							Operation not recommended							
	15.0	3.3	7.5	1700	54.8	37.0	0.67	5.58	73.8	9.8	14.6	Operation not recommended						
				2200	56.5	42.4	0.75	5.94	76.8	9.5	15.9	Operation not recommended						
	18.0	4.4	10.2	1700	56.1	39.1	0.70	5.41	74.6	10.4	13.6	Operation not recommended						
2200				57.9	44.9	0.78	5.76	77.6	10.0	15.1	Operation not recommended							
120	12.0	2.2	5.0	Operation not recommended							Operation not recommended							
	15.0	3.1	7.2	1700	52.0	37.4	0.72	6.27	73.4	8.3	17.7	Operation not recommended						
				2200	53.4	43.0	0.80	6.60	76.0	8.1	19.2	Operation not recommended						
	18.0	4.3	9.8	1700	53.4	40.0	0.75	6.06	74.1	8.8	16.4	Operation not recommended						
2200				54.9	45.9	0.84	6.38	76.7	8.6	18.2	Operation not recommended							

Performance Data cont.

Model 026 - Part Load Dual Capacity with Variable Speed ECM or 5-Speed ECM (700 cfm)

EWT °F	Flow Rate GPM	WPD		HEATING - EAT 70°F							COOLING - EAT 80/67 °F							
				Airflow CFM	HC MBtu/h	Power kW	HE MBtu/h	LAT °F	COP	HWC Mbtu/h	Airflow CFM	TC Mbtu/h	SC Mbtu/h	S/T Ratio	Power kW	HR Mbtu/h	EER	HWC Mbtu/h
		PSI	FT/HD	Operation not recommended							Operation not recommended							
20	3.0	0.8	1.9	Operation not recommended							Operation not recommended							
	5.0	2.0	4.7	Operation not recommended							Operation not recommended							
	7.0	3.7	8.7	500	11.9	1.06	8.3	92.0	3.28	1.8	Operation not recommended							
				700	12.4	1.09	8.7	86.4	3.33	1.6	Operation not recommended							
30	3.0	0.8	1.8	Operation not recommended							Operation not recommended							
	5.0	2.0	4.5	500	13.1	1.06	9.5	94.3	3.61	1.8	500	22.5	14.1	0.63	0.52	24.3	43.3	-
				700	13.7	1.09	9.9	88.1	3.66	1.6	700	22.9	15.4	0.67	0.55	24.8	41.8	-
	7.0	3.6	8.4	500	13.9	1.09	10.2	95.8	3.75	1.8	500	22.6	14.1	0.62	0.50	24.4	44.9	-
				700	14.5	1.12	10.7	89.2	3.80	1.6	700	23.2	15.4	0.66	0.53	25.0	43.8	-
	40	3.0	0.8	1.8	Operation not recommended							Operation not recommended						
5.0		1.9	4.4	500	15.3	1.06	11.7	98.3	4.21	1.8	500	23.3	14.7	0.63	0.58	25.3	40.1	-
				700	15.8	1.08	12.1	90.9	4.28	1.7	700	23.7	16.0	0.67	0.61	25.8	38.9	-
7.0		3.5	8.2	500	16.1	1.09	12.4	99.8	4.33	1.9	500	23.5	14.7	0.62	0.56	25.4	41.6	-
				700	16.7	1.11	12.9	92.0	4.40	1.7	700	24.0	16.0	0.67	0.59	26.0	40.7	-
50		3.0	0.7	1.7	500	16.8	1.06	13.2	101.2	4.65	1.9	500	23.5	14.5	0.62	0.66	25.8	35.6
	700				17.4	1.08	13.7	93.0	4.73	1.7	700	24.2	16.1	0.67	0.67	26.5	35.9	0.8
	5.0	1.8	4.3	500	17.4	1.06	13.8	102.3	4.81	1.9	500	23.7	14.6	0.62	0.64	25.9	36.9	0.7
				700	18.0	1.08	14.3	93.8	4.90	1.8	700	24.4	16.2	0.66	0.66	26.6	37.2	0.7
	7.0	3.4	7.9	500	18.3	1.09	14.6	103.8	4.92	2.0	500	24.1	15.0	0.62	0.64	26.3	37.8	0.6
				700	18.8	1.10	15.0	94.9	5.01	1.8	700	24.8	16.6	0.67	0.65	27.0	38.2	0.7
60	3.0	0.7	1.7	500	19.4	1.08	15.7	105.9	5.28	2.1	500	23.1	14.5	0.63	0.75	25.7	30.7	1.0
				700	19.9	1.09	16.2	96.3	5.37	1.9	700	23.7	16.0	0.68	0.77	26.4	31.0	1.0
	5.0	1.8	4.1	500	20.2	1.08	16.5	107.4	5.50	2.1	500	23.3	14.6	0.63	0.73	25.8	31.8	0.9
				700	20.7	1.08	17.0	97.3	5.60	2.0	700	24.0	16.1	0.67	0.75	26.5	32.1	1.0
	7.0	3.3	7.6	500	20.9	1.10	17.1	108.7	5.56	2.2	500	23.7	15.0	0.63	0.73	26.2	32.6	0.8
				700	21.4	1.11	17.6	98.2	5.66	2.0	700	24.4	16.6	0.68	0.74	26.9	32.9	0.9
70	3.0	0.7	1.6	500	21.9	1.09	18.2	110.6	5.88	2.3	500	22.7	14.5	0.64	0.84	25.6	26.9	1.3
				700	22.4	1.09	18.6	99.6	5.99	2.1	700	23.3	16.0	0.69	0.86	26.2	27.1	1.4
	5.0	1.7	4.0	500	22.9	1.09	19.2	112.4	6.16	2.4	500	22.9	14.5	0.64	0.82	25.7	27.8	1.3
				700	23.3	1.09	19.6	100.8	6.28	2.2	700	23.5	16.1	0.68	0.84	26.4	28.1	1.4
	7.0	3.2	7.4	500	23.5	1.11	19.7	113.5	6.19	2.4	500	23.3	14.9	0.64	0.81	26.0	28.6	1.2
				700	23.9	1.11	20.1	101.6	6.31	2.2	700	23.9	16.5	0.69	0.83	26.7	28.8	1.3
80	3.0	0.7	1.6	500	24.4	1.12	20.5	115.1	6.35	2.6	500	21.1	13.8	0.65	0.97	24.4	21.8	1.8
				700	24.7	1.12	20.9	102.7	6.47	2.4	700	21.7	15.3	0.70	0.99	25.1	21.9	1.9
	5.0	1.7	3.9	500	25.5	1.12	21.7	117.3	6.70	2.6	500	21.3	13.9	0.65	0.95	24.5	22.5	1.7
				700	25.8	1.11	22.0	104.2	6.83	2.4	700	21.9	15.4	0.70	0.96	25.2	22.7	1.9
	7.0	3.1	7.1	500	25.9	1.14	22.0	117.9	6.65	2.7	500	21.6	14.2	0.66	0.94	24.8	23.1	1.6
				700	26.2	1.13	22.3	104.6	6.78	2.5	700	22.3	15.8	0.71	0.96	25.5	23.3	1.8
90	3.0	0.7	1.5	500	26.8	1.16	22.8	119.6	6.79	2.9	500	19.5	13.1	0.67	1.10	23.3	17.8	2.4
				700	27.0	1.14	23.1	105.7	6.93	2.7	700	20.1	14.5	0.72	1.12	23.9	18.0	2.6
	5.0	1.6	3.7	500	28.1	1.15	24.2	122.1	7.20	3.0	500	19.7	13.2	0.67	1.07	23.4	18.4	2.3
				700	28.3	1.13	24.5	107.5	7.35	2.8	700	20.3	14.6	0.72	1.09	24.0	18.6	2.5
	7.0	3.0	6.9	500	28.3	1.17	24.3	122.4	7.09	3.1	500	20.0	13.6	0.68	1.06	23.7	18.9	2.1
				700	28.4	1.15	24.5	107.6	7.24	2.8	700	20.6	15.0	0.73	1.08	24.3	19.1	2.4
100	3.0	0.6	1.5	Operation not recommended							Operation not recommended							
	5.0	1.6	3.6	500	18.2	1.26	0.69	1.23	22.4	14.9	3.0	Operation not recommended						
				700	18.7	1.40	0.75	1.25	23.0	15.0	3.2	Operation not recommended						
	7.0	2.9	6.6	500	18.5	1.30	0.70	1.22	22.7	15.2	2.8	Operation not recommended						
700				19.1	1.44	0.75	1.24	23.3	15.4	3.1	Operation not recommended							
110	3.0	0.6	1.4	Operation not recommended							Operation not recommended							
	5.0	1.5	3.4	500	16.8	1.21	0.72	1.39	21.5	12.1	3.8	Operation not recommended						
				700	17.2	1.34	0.78	1.41	22.0	12.2	4.1	Operation not recommended						
	7.0	2.8	6.4	500	17.0	1.24	0.73	1.37	21.7	12.4	3.5	Operation not recommended						
700				17.5	1.37	0.78	1.40	22.3	12.5	3.9	Operation not recommended							
120	3.0	0.6	1.3	Operation not recommended							Operation not recommended							
	5.0	1.4	3.3	500	16.2	1.24	0.77	1.59	21.6	10.2	4.7	Operation not recommended						
				700	16.5	1.35	0.82	1.63	22.1	10.1	5.1	Operation not recommended						
	7.0	2.7	6.1	500	16.4	1.24	0.76	1.54	21.6	10.6	4.3	Operation not recommended						
700				16.7	1.35	0.81	1.59	22.1	10.5	4.8	Operation not recommended							

Performance capacities shown in thousands of Btuh

9/16/14

Performance Data cont.

Model 026 - Full Load Dual Capacity with Variable Speed ECM or 5-Speed ECM (900 cfm)

EWT °F	Flow Rate GPM	WPD		HEATING - EAT 70°F							COOLING - EAT 80/67 °F										
				Airflow CFM	HC MBtu/h	Power kW	HE MBtu/h	LAT °F	COP	HWC Mbtu/h	Airflow CFM	TC Mbtu/h	SC Mbtu/h	S/T Ratio	Power kW	HR Mbtu/h	EER	HWC Mbtu/h			
		PSI	FT/HD	Operation not recommended							Operation not recommended										
20	4.0	1.4	3.2	Operation not recommended							Operation not recommended										
	6.0	2.9	6.6	Operation not recommended							Operation not recommended										
	8.0	4.8	11.1	700	16.5	1.42	11.6	91.8	3.40	2.1	900	17.0	1.46	12.0	87.5	3.41	2.0				
30	4.0	1.4	3.2	Operation not recommended							Operation not recommended										
	6.0	2.8	6.4	700	18.9	1.45	13.9	95.0	3.82	2.3	700	29.8	18.6	0.62	0.93	33.0	32.0	---			
				900	19.4	1.50	14.3	90.0	3.81	2.1	900	30.3	20.3	0.67	0.98	33.6	30.8	---			
				700	19.2	1.47	14.2	95.4	3.84	2.3	700	30.0	18.6	0.62	0.90	33.1	33.1	---			
				900	19.8	1.51	14.7	90.4	3.85	2.2	900	30.7	20.3	0.66	0.95	33.9	32.3	---			
40	4.0	1.3	3.1	Operation not recommended							Operation not recommended										
	6.0	2.7	6.2	700	21.5	1.50	16.4	98.5	4.21	2.5	700	30.1	19.1	0.63	1.02	33.6	29.4	-			
				900	22.2	1.53	17.0	92.8	4.25	2.3	900	30.7	20.8	0.68	1.07	34.3	28.5	-			
				700	22.0	1.51	16.8	99.1	4.25	2.6	700	30.3	19.1	0.63	0.99	33.7	30.5	-			
				900	22.7	1.55	17.4	93.3	4.30	2.4	900	31.0	20.8	0.67	1.04	34.5	29.8	-			
50	4.0	1.3	3.0	700	23.3	1.51	18.2	100.9	4.53	2.7	700	28.8	17.8	0.62	1.17	32.8	24.6	1.3			
				900	24.0	1.53	18.8	94.7	4.60	2.5	900	30.3	19.7	0.65	1.23	34.5	24.6	1.4			
	6.0	2.6	6.0	700	24.2	1.55	18.9	102.0	4.59	2.8	700	29.4	18.0	0.61	1.10	33.2	26.7	1.3			
				900	25.0	1.57	19.6	95.7	4.67	2.6	900	31.0	20.0	0.64	1.16	34.9	26.8	1.4			
				700	24.7	1.56	19.4	102.7	4.65	2.9	700	29.7	19.2	0.65	1.08	33.4	27.6	1.2			
60	4.0	1.2	2.9	700	26.0	1.58	20.6	104.4	4.82	3.1	700	28.5	17.9	0.63	1.28	32.9	22.3	1.6			
				900	26.8	1.59	21.4	97.6	4.94	2.9	900	29.9	19.9	0.67	1.34	34.4	22.3	1.7			
	6.0	2.5	5.8	700	27.2	1.63	21.6	105.9	4.90	3.2	700	29.2	18.1	0.62	1.22	33.3	24.0	1.5			
				900	28.1	1.64	22.5	98.9	5.02	2.9	900	30.5	20.1	0.66	1.27	34.9	24.1	1.6			
				700	27.8	1.64	22.2	106.8	4.96	3.3	700	29.4	19.1	0.65	1.19	33.5	24.8	1.4			
70	4.0	1.2	2.8	700	28.7	1.65	23.1	108.0	5.09	3.5	700	28.2	18.0	0.64	1.39	32.9	20.3	2.0			
				900	29.7	1.65	24.0	100.5	5.27	3.2	900	29.4	20.1	0.68	1.44	34.3	20.4	2.1			
	6.0	2.4	5.6	700	30.2	1.71	24.3	109.9	5.18	3.6	700	28.9	18.2	0.63	1.33	33.4	21.7	1.9			
				900	31.2	1.71	25.3	102.1	5.35	3.3	900	30.1	20.2	0.67	1.38	34.8	21.9	2.0			
				700	30.9	1.73	25.1	110.9	5.25	3.7	700	29.2	19.0	0.65	1.30	33.6	22.5	1.7			
80	4.0	1.2	2.7	700	31.2	1.75	25.3	111.3	5.23	3.9	700	27.0	17.8	0.66	1.54	32.2	17.5	2.5			
				900	32.3	1.74	26.4	103.3	5.46	3.6	900	28.0	19.8	0.71	1.59	33.5	17.7	2.7			
	6.0	2.4	5.4	700	33.0	1.82	26.8	113.7	5.32	4.0	700	27.7	18.0	0.65	1.49	32.8	18.6	2.3			
				900	34.2	1.80	28.0	105.1	5.56	3.7	900	28.8	20.0	0.69	1.53	34.0	18.8	2.5			
				700	34.0	1.84	27.7	115.0	5.41	4.1	700	28.0	18.5	0.66	1.46	33.0	19.2	2.2			
90	4.0	1.1	2.6	700	35.2	1.82	29.0	106.2	5.68	3.8	900	29.2	20.5	0.70	1.50	34.3	19.4	2.4			
				700	33.8	1.85	27.5	114.7	5.36	4.3	700	25.7	17.6	0.68	1.69	31.5	15.2	3.1			
				900	35.0	1.82	28.8	106.0	5.63	4.0	900	26.7	19.5	0.73	1.73	32.6	15.4	3.3			
	6.0	2.3	5.2	700	35.9	1.93	29.3	117.5	5.45	4.5	700	26.5	17.8	0.67	1.64	32.1	16.1	2.9			
				900	37.2	1.90	30.7	108.2	5.74	4.1	900	27.5	19.8	0.72	1.68	33.2	16.3	3.2			
100	4.0	1.1	2.5	Operation not recommended							Operation not recommended										
	6.0	2.2	5.1	Operation not recommended							Operation not recommended										
	8.0	3.7	8.5	700	25.2	1.72	26.8	113.7	5.32	4.0	700	27.7	18.0	0.65	1.49	32.8	18.6	2.3			
				900	35.2	1.82	29.0	106.2	5.68	3.8	900	29.2	20.5	0.70	1.50	34.3	19.4	2.4			
110	4.0	1.0	2.4	Operation not recommended							Operation not recommended										
	6.0	2.1	4.9	Operation not recommended							Operation not recommended										
	8.0	3.5	8.2	700	23.3	1.65	23.1	108.0	5.09	3.5	700	28.2	18.0	0.64	1.39	32.9	20.3	2.0			
				900	24.0	1.68	23.8	100.5	5.27	3.2	900	29.4	20.1	0.68	1.44	34.3	20.4	2.1			
120	4.0	1.0	2.3	Operation not recommended							Operation not recommended										
	6.0	2.0	4.7	Operation not recommended							Operation not recommended										
	8.0	3.4	7.9	700	21.6	1.61	21.6	104.4	4.82	3.1	700	28.5	17.9	0.63	1.28	32.9	22.3	1.6			
				900	22.0	1.64	22.2	98.9	5.02	2.9	900	29.9	19.9	0.67	1.34	34.4	22.3	1.7			

Performance Data cont.

Model 038 - Part Load Dual Capacity with Variable Speed ECM or 5-Speed ECM (1050 cfm)

EWT °F	Flow Rate GPM	WPD		HEATING - EAT 70°F							COOLING - EAT 80/67 °F								
				Airflow CFM	HC MBtu/h	Power kW	HE MBtu/h	LAT °F	COP	HWC Mbtu/h	Airflow CFM	TC Mbtu/h	SC Mbtu/h	S/T Ratio	Power kW	HR Mbtu/h	EER	HWC Mbtu/h	
		PSI	FT/HD	Operation not recommended							Operation not recommended								
20	4.0	0.9	2.1	Operation not recommended							Operation not recommended								
	6.0	1.7	4.0	Operation not recommended							Operation not recommended								
	8.0	2.9	6.7	900	17.6	1.63	12.1	88.1	3.17	2.5	Operation not recommended								
				1050	18.4	1.67	12.7	86.2	3.22	2.3	Operation not recommended								
30	4.0	0.9	2.0	Operation not recommended							Operation not recommended								
	6.0	1.7	3.9	900	19.2	1.58	13.8	89.8	3.57	2.4	900	29.5	19.1	0.65	0.74	32.0	40.1	---	
				1050	20.0	1.62	14.5	87.7	3.62	2.2	1050	30.0	20.9	0.70	0.78	32.6	38.7	---	
	8.0	2.8	6.5	900	20.5	1.62	14.9	91.0	3.71	2.5	900	29.7	19.1	0.64	0.71	32.1	41.5	---	
				1050	21.3	1.66	15.6	88.8	3.76	2.3	1050	30.4	20.9	0.69	0.75	33.0	40.5	---	
40	4.0	0.8	1.9	Operation not recommended							Operation not recommended								
	6.0	1.6	3.8	900	22.5	1.60	17.0	93.1	4.11	2.5	900	30.8	20.6	0.67	0.81	33.5	37.8	-	
				1050	23.3	1.63	17.7	90.5	4.17	2.3	1050	31.3	22.5	0.72	0.85	34.3	36.8	-	
	8.0	2.7	6.3	900	23.7	1.64	18.1	94.4	4.23	2.6	900	31.0	20.6	0.66	0.79	33.7	39.3	-	
				1050	24.5	1.67	18.8	91.6	4.29	2.4	1050	31.7	22.5	0.71	0.83	34.5	38.4	-	
50	4.0	0.8	1.9	900	24.8	1.63	19.3	95.5	4.47	2.6	900	31.3	21.1	0.67	0.91	34.4	34.2	1.0	
				1050	25.6	1.65	20.0	92.6	4.55	2.4	1050	32.2	23.4	0.73	0.93	35.4	34.5	1.1	
	6.0	1.6	3.7	900	25.7	1.63	20.1	96.4	4.62	2.7	900	31.6	21.2	0.67	0.89	34.6	35.5	0.9	
				1050	26.5	1.65	20.8	93.3	4.70	2.5	1050	32.5	23.5	0.72	0.91	35.6	35.8	1.0	
	8.0	2.6	6.1	900	26.9	1.67	21.2	97.7	4.73	2.8	900	32.1	21.8	0.68	0.88	35.1	36.4	0.9	
				1050	27.7	1.69	21.9	94.4	4.81	2.5	1050	33.0	24.1	0.73	0.90	36.1	36.7	1.0	
60	4.0	0.8	1.8	900	28.1	1.67	22.4	98.9	4.94	2.9	900	30.5	20.8	0.68	1.04	34.0	29.4	1.3	
				1050	28.8	1.68	23.1	95.4	5.03	2.6	1050	31.3	23.1	0.74	1.06	35.0	29.7	1.4	
	6.0	1.5	3.6	900	29.3	1.67	23.6	100.1	5.15	3.0	900	30.8	21.0	0.68	1.01	34.2	30.5	1.3	
				1050	29.9	1.68	24.2	96.4	5.24	2.7	1050	31.6	23.2	0.73	1.03	35.1	30.7	1.4	
	8.0	2.5	5.9	900	30.3	1.70	24.5	101.2	5.21	3.0	900	31.3	21.5	0.69	1.00	34.7	31.3	1.2	
				1050	31.0	1.71	25.1	97.3	5.30	2.8	1050	32.2	23.8	0.74	1.02	35.6	31.5	1.3	
70	4.0	0.8	1.8	900	31.4	1.71	25.6	102.3	5.39	3.2	900	29.7	20.6	0.69	1.16	33.6	25.6	1.9	
				1050	32.0	1.71	26.2	98.3	5.49	2.9	1050	30.5	22.8	0.75	1.18	34.5	25.8	2.0	
	6.0	1.5	3.5	900	32.8	1.70	27.0	103.7	5.64	3.3	900	30.0	20.7	0.69	1.13	33.8	26.6	1.7	
				1050	33.4	1.70	27.6	99.4	5.75	3.0	1050	30.8	22.9	0.74	1.15	34.7	26.8	1.9	
	8.0	2.5	5.7	900	33.6	1.74	27.7	104.6	5.67	3.4	900	30.5	21.2	0.70	1.12	34.3	27.2	1.6	
				1050	34.2	1.74	28.3	100.2	5.78	3.1	1050	31.3	23.5	0.75	1.14	35.2	27.5	1.8	
80	4.0	0.7	1.7	900	35.0	1.77	29.0	106.0	5.80	3.6	900	28.1	19.8	0.70	1.33	32.6	21.1	2.5	
				1050	35.5	1.76	29.5	101.3	5.91	3.3	1050	28.9	21.9	0.76	1.36	33.5	21.3	2.7	
	6.0	1.4	3.3	900	36.7	1.76	30.7	107.7	6.12	3.7	900	28.3	19.9	0.70	1.30	32.8	21.9	2.4	
				1050	37.1	1.74	31.1	102.7	6.24	3.4	1050	29.1	22.0	0.76	1.32	33.6	22.0	2.6	
	8.0	2.4	5.5	900	37.2	1.79	31.1	108.3	6.08	3.8	900	28.8	20.4	0.71	1.29	33.2	22.4	2.2	
				1050	37.6	1.78	31.5	103.1	6.20	3.5	1050	29.6	22.6	0.76	1.31	34.1	22.6	2.5	
90	4.0	0.7	1.6	900	38.6	1.83	32.3	109.7	6.19	4.0	900	26.5	18.9	0.71	1.50	31.6	17.6	3.4	
				1050	38.9	1.81	32.7	104.3	6.31	3.7	1050	27.2	20.9	0.77	1.53	32.4	17.7	3.6	
	6.0	1.4	3.2	900	40.5	1.81	34.4	111.7	6.56	4.2	900	26.7	19.0	0.71	1.46	31.7	18.2	3.2	
				1050	40.8	1.79	34.7	106.0	6.70	3.8	1050	27.4	21.1	0.77	1.49	32.5	18.4	3.4	
	8.0	2.3	5.3	900	40.7	1.85	34.4	111.9	6.46	4.3	900	27.1	19.5	0.72	1.45	32.1	18.7	2.9	
				1050	40.9	1.82	34.7	106.1	6.59	4.0	1050	27.9	21.6	0.77	1.48	32.9	18.9	3.3	
100	4.0	0.7	1.6	Operation not recommended							Operation not recommended								
	6.0	1.3	3.1	Operation not recommended							Operation not recommended								
	8.0	2.2	5.1	900	24.9	18.6	0.75	1.68	30.6	14.8	4.1	900	25.3	19.1	0.75	1.67	31.0	15.2	3.8
				1050	25.6	20.6	0.80	1.72	31.4	14.9	4.5	1050	26.0	21.1	0.81	1.70	31.8	15.3	4.2
110	4.0	0.7	1.5	Operation not recommended							Operation not recommended								
	6.0	1.3	3.0	Operation not recommended							Operation not recommended								
	8.0	2.1	4.9	900	23.1	18.1	0.79	1.90	29.6	12.1	5.2	900	23.7	20.1	0.85	1.94	30.3	12.2	5.7
				1050	23.4	18.6	0.79	1.88	29.9	12.4	4.8	1050	24.1	20.6	0.85	1.92	30.7	12.6	5.4
120	4.0	0.6	1.5	Operation not recommended							Operation not recommended								
	6.0	1.2	2.9	Operation not recommended							Operation not recommended								
	8.0	2.0	4.7	900	22.2	18.8	0.85	2.18	29.7	10.2	6.5	900	22.6	20.4	0.90	2.24	30.3	10.1	7.0
				1050	22.4	18.8	0.84	2.11	29.6	10.6	6.0	1050	22.9	20.4	0.89	2.18	30.3	10.5	6.7

Performance Data cont.

Model 038 - Full Load Dual Capacity with Variable Speed ECM or 5-Speed ECM (1250 cfm)

EWT °F	Flow Rate GPM	WPD		HEATING - EAT 70°F							COOLING - EAT 80/67 °F							
				Airflow CFM	HC MBtu/h	Power kW	HE MBtu/h	LAT °F	COP	HWC Mbtu/h	Airflow CFM	TC Mbtu/h	SC Mbtu/h	S/T Ratio	Power kW	HR Mbtu/h	EER	HWC Mbtu/h
		PSI	FT/HD	Operation not recommended							Operation not recommended							
20	5.0	1.3	3.0	Operation not recommended							Operation not recommended							
	7.0	2.3	5.2	Operation not recommended							Operation not recommended							
	9.0	3.5	8.1	1050	25.2	2.21	17.7	92.2	3.34	2.9	Operation not recommended							
				1250	26.0	2.28	18.2	89.3	3.34	2.6	Operation not recommended							
30	5.0	1.2	2.9	Operation not recommended							Operation not recommended							
	7.0	2.2	5.1	1050	28.8	2.24	21.1	95.4	3.77	3.1	1050	39.3	25.2	0.64	1.43	44.2	27.4	-
				1250	29.6	2.31	21.7	91.9	3.76	2.8	1250	40.0	27.5	0.69	1.51	45.1	26.5	-
	9.0	3.4	7.9	1050	29.2	2.26	21.5	95.8	3.79	3.2	1050	39.5	25.2	0.64	1.39	44.3	28.4	-
				1250	30.2	2.33	22.3	92.4	3.80	2.9	1250	40.5	27.5	0.68	1.46	45.5	27.7	-
40	5.0	1.2	2.8	Operation not recommended							Operation not recommended							
	7.0	2.1	4.9	1050	32.7	2.32	24.8	98.8	4.12	3.4	1050	40.6	26.4	0.65	1.60	46.0	25.4	-
				1250	33.7	2.37	25.6	95.0	4.16	3.1	1250	41.3	28.8	0.70	1.67	47.0	24.7	-
	9.0	3.3	7.6	1050	33.3	2.35	25.3	99.4	4.16	3.5	1050	40.9	26.4	0.65	1.55	46.2	26.4	-
				1250	34.4	2.40	26.2	95.5	4.21	3.2	1250	41.8	28.8	0.69	1.62	47.3	25.8	-
50	5.0	1.2	2.7	1050	35.3	2.36	27.3	101.1	4.39	3.7	1050	39.7	25.1	0.63	1.84	46.0	21.5	1.9
				1250	36.4	2.39	28.2	96.9	4.46	3.4	1250	41.8	27.9	0.67	1.94	48.4	21.5	2.0
	7.0	2.1	4.8	1050	36.6	2.41	28.4	102.3	4.45	3.8	1050	40.5	25.4	0.63	1.74	46.5	23.3	1.8
				1250	37.8	2.44	29.4	98.0	4.53	3.5	1250	42.6	28.2	0.66	1.82	48.8	23.4	1.9
	9.0	3.2	7.4	1050	37.4	2.43	29.1	103.0	4.51	3.9	1050	40.9	27.1	0.66	1.69	46.7	24.1	1.7
1250				38.6	2.47	30.2	98.6	4.59	3.6	1250	43.1	30.1	0.70	1.78	49.2	24.2	1.8	
60	5.0	1.1	2.6	1050	38.7	2.47	30.3	104.1	4.60	4.2	1050	39.4	25.8	0.66	2.00	46.2	19.7	2.3
				1250	40.0	2.48	31.5	99.6	4.72	3.8	1250	41.3	28.7	0.70	2.09	48.4	19.8	2.4
	7.0	2.0	4.6	1050	40.5	2.54	31.8	105.7	4.68	4.3	1050	40.4	26.1	0.65	1.90	46.8	21.3	2.2
				1250	41.8	2.55	33.1	100.9	4.80	4.0	1250	42.3	29.0	0.69	1.98	49.0	21.4	2.3
	9.0	3.1	7.2	1050	41.4	2.56	32.7	106.5	4.74	4.4	1050	40.7	27.5	0.68	1.85	47.1	22.0	2.0
1250				42.8	2.57	34.0	101.7	4.88	4.1	1250	42.8	30.6	0.71	1.94	49.4	22.1	2.2	
70	5.0	1.1	2.5	1050	42.1	2.57	33.4	107.2	4.80	4.7	1050	39.2	26.6	0.68	2.15	46.5	18.2	2.9
				1250	43.6	2.57	34.8	102.3	4.96	4.3	1250	40.9	29.6	0.72	2.23	48.5	18.3	3.0
	7.0	1.9	4.5	1050	44.3	2.66	35.2	109.1	4.88	4.8	1050	40.2	26.9	0.67	2.06	47.2	19.5	2.7
				1250	45.8	2.66	36.7	103.9	5.04	4.4	1250	41.9	29.8	0.71	2.13	49.2	19.7	2.9
	9.0	3.0	6.9	1050	45.5	2.69	36.3	110.1	4.95	5.0	1050	40.6	28.0	0.69	2.01	47.4	20.2	2.5
1250				47.0	2.68	37.9	104.8	5.14	4.6	1250	42.4	31.0	0.73	2.09	49.5	20.3	2.8	
80	5.0	1.1	2.5	1050	45.4	2.72	36.2	110.1	4.89	5.2	1050	37.5	26.1	0.70	2.34	45.4	16.0	3.6
				1250	47.0	2.70	37.8	104.8	5.10	4.8	1250	39.0	29.0	0.74	2.41	47.2	16.1	3.8
	7.0	1.9	4.3	1050	48.1	2.83	38.4	112.4	4.98	5.4	1050	38.5	26.4	0.69	2.26	46.2	17.0	3.3
				1250	49.7	2.80	40.1	106.8	5.20	5.0	1250	40.0	29.2	0.73	2.33	48.0	17.2	3.6
	9.0	2.9	6.7	1050	49.5	2.87	39.7	113.6	5.05	5.6	1050	38.9	27.0	0.69	2.21	46.4	17.6	3.1
1250				51.2	2.83	41.5	107.9	5.31	5.1	1250	40.5	30.0	0.74	2.28	48.3	17.8	3.4	
90	5.0	1.0	2.4	1050	48.8	2.87	39.0	113.0	4.97	5.9	1050	35.8	25.5	0.71	2.53	44.4	14.1	4.4
				1250	50.5	2.83	40.8	107.4	5.23	5.4	1250	37.0	28.4	0.77	2.59	45.9	14.3	4.7
	7.0	1.8	4.2	1050	51.8	3.00	41.6	115.7	5.06	6.0	1050	36.8	25.9	0.70	2.46	45.2	15.0	4.1
				1250	53.7	2.95	43.6	109.8	5.33	5.6	1250	38.2	28.7	0.75	2.52	46.8	15.1	4.5
	9.0	2.8	6.5	1050	53.5	3.05	43.1	117.1	5.14	6.2	1050	37.2	26.1	0.70	2.42	45.5	15.4	3.9
1250				55.3	2.97	45.2	111.0	5.46	5.8	1250	38.6	28.9	0.75	2.47	47.0	15.6	4.3	
100	5.0	1.0	2.3	Operation not recommended							Operation not recommended							
	7.0	1.7	4.0	1050	34.6	25.0	0.72	2.73	43.9	12.7	5.1	Operation not recommended						
				1250	35.7	27.7	0.78	2.77	45.2	12.9	5.5	Operation not recommended						
	9.0	2.7	6.2	1050	35.0	24.9	0.71	2.68	44.1	13.1	4.8	Operation not recommended						
1250				36.1	27.6	0.76	2.72	45.4	13.3	5.3	Operation not recommended							
110	5.0	1.0	2.2	Operation not recommended							Operation not recommended							
	7.0	1.7	3.9	1050	32.4	24.1	0.74	2.99	42.6	10.8	6.2	Operation not recommended						
				1250	33.3	26.7	0.80	3.01	43.5	11.0	6.8	Operation not recommended						
	9.0	2.6	6.0	1050	32.7	23.7	0.73	2.94	42.7	11.1	5.8	Operation not recommended						
1250				33.6	26.2	0.78	2.97	43.7	11.3	6.4	Operation not recommended							
120	5.0	0.9	2.1	Operation not recommended							Operation not recommended							
	7.0	1.6	3.7	1050	30.6	23.3	0.76	3.31	41.9	9.2	7.5	Operation not recommended						
				1250	31.1	25.3	0.81	3.39	42.7	9.2	8.1	Operation not recommended						
	9.0	2.5	5.8	1050	30.8	23.3	0.76	3.20	41.8	9.6	7.0	Operation not recommended						
1250				31.5	25.3	0.80	3.30	42.8	9.5	7.7	Operation not recommended							

Performance Data cont.

Model 049 - Part Load Dual Capacity with Variable Speed ECM or 5-Speed ECM (1350 cfm)

EWT °F	Flow Rate GPM	WPD		HEATING - EAT 70°F							COOLING - EAT 80/67 °F							
				Airflow CFM	HC MBtu/h	Power kW	HE MBtu/h	LAT °F	COP	HWC Mbtu/h	Airflow CFM	TC Mbtu/h	SC Mbtu/h	S/T Ratio	Power kW	HR Mbtu/h	EER	HWC Mbtu/h
		PSI	FT/HD	Operation not recommended							Operation not recommended							
20	5.0	0.9	2.2	Operation not recommended							Operation not recommended							
	8.0	2.0	4.6	Operation not recommended							Operation not recommended							
	11.0	3.4	7.8	1150	23.5	2.20	15.9	88.9	3.12	4.2	Operation not recommended							
				1350	24.3	2.24	16.7	86.7	3.19	3.8	Operation not recommended							
30	5.0	0.9	2.1	Operation not recommended							Operation not recommended							
	8.0	1.9	4.4	1150	26.5	2.20	19.0	91.3	3.52	4.3	1150	37.5	21.5	0.57	1.10	41.2	34.1	---
				1350	27.3	2.22	19.7	88.7	3.61	3.9	1350	38.1	23.5	0.62	1.16	42.0	32.9	---
	11.0	3.3	7.6	1150	27.1	2.22	19.6	91.8	3.59	4.4	1150	37.7	21.5	0.57	1.07	41.3	35.3	---
				1350	28.1	2.25	20.4	89.3	3.66	4.0	1350	38.6	23.5	0.61	1.12	42.4	34.5	---
40	5.0	0.9	2.0	Operation not recommended							Operation not recommended							
	8.0	1.9	4.3	1150	29.9	2.23	22.3	94.1	3.93	4.5	1150	39.5	23.4	0.59	1.21	43.6	32.6	-
				1350	31.0	2.23	23.3	91.2	4.06	4.2	1350	40.2	25.6	0.64	1.27	44.6	31.7	-
	11.0	3.2	7.4	1150	30.9	2.25	23.2	94.9	4.03	4.7	1150	39.8	23.4	0.59	1.18	43.8	33.8	-
				1350	32.0	2.26	24.2	91.9	4.14	4.2	1350	40.7	25.6	0.63	1.23	44.9	33.1	-
50	5.0	0.9	2.0	1150	31.0	2.19	23.5	94.9	4.14	4.8	1150	40.4	23.3	0.58	1.56	45.7	25.9	1.6
				1350	32.0	2.19	24.5	91.9	4.27	4.4	1350	41.7	27.5	0.66	1.63	47.2	25.6	1.7
	8.0	1.8	4.2	1150	33.4	2.26	25.7	96.9	4.32	4.9	1150	41.3	23.5	0.57	1.35	45.9	30.5	1.5
				1350	34.7	2.25	27.0	93.8	4.51	4.5	1350	42.5	27.6	0.65	1.42	47.4	30.0	1.6
	11.0	3.1	7.2	1150	34.7	2.28	26.9	97.9	4.46	5.1	1150	41.5	23.5	0.56	1.27	45.9	32.6	1.4
1350				35.8	2.28	28.0	94.6	4.60	4.6	1350	42.8	27.6	0.65	1.34	47.4	31.9	1.5	
60	5.0	0.8	1.9	1150	33.7	2.23	26.1	97.1	4.42	5.2	1150	39.5	23.3	0.59	1.69	45.3	23.4	2.3
				1350	34.9	2.22	27.3	93.9	4.61	4.8	1350	40.7	27.5	0.67	1.76	46.8	23.1	2.4
	8.0	1.8	4.0	1150	36.5	2.29	28.6	99.3	4.67	5.4	1150	40.2	23.5	0.59	1.50	45.3	26.8	2.1
				1350	37.9	2.26	30.2	96.0	4.91	5.0	1350	41.4	27.7	0.67	1.57	46.7	26.4	2.3
	11.0	3.0	6.9	1150	38.0	2.31	30.1	100.6	4.83	5.5	1150	40.6	23.6	0.58	1.42	45.5	28.6	1.9
1350				39.4	2.28	31.6	97.0	5.06	5.1	1350	41.9	27.7	0.66	1.49	46.9	28.2	2.2	
70	5.0	0.8	1.8	1150	36.4	2.27	28.7	99.3	4.71	5.8	1150	38.6	23.3	0.60	1.81	44.8	21.3	3.2
				1350	37.9	2.24	30.2	96.0	4.95	5.4	1350	39.8	27.4	0.69	1.90	46.3	21.0	3.4
	8.0	1.7	3.9	1150	39.5	2.31	31.7	101.8	5.02	6.0	1150	39.0	23.6	0.60	1.64	44.6	23.8	3.0
				1350	41.1	2.27	33.4	98.2	5.31	5.5	1350	40.2	27.7	0.69	1.72	46.1	23.5	3.2
	11.0	2.9	6.7	1150	41.3	2.33	33.4	103.3	5.19	6.1	1150	39.7	23.7	0.60	1.57	45.0	25.3	2.8
1350				42.9	2.28	35.1	99.4	5.51	5.7	1350	40.9	27.8	0.68	1.63	46.5	25.1	3.1	
80	5.0	0.8	1.8	1150	39.3	2.31	31.4	101.6	4.99	6.5	1150	37.5	22.3	0.60	2.01	44.3	18.6	4.4
				1350	40.8	2.27	33.1	98.0	5.27	6.0	1350	38.7	26.2	0.68	2.10	45.8	18.4	4.6
	8.0	1.6	3.8	1150	42.6	2.33	34.7	104.3	5.36	6.7	1150	37.7	22.5	0.60	1.87	44.1	20.1	4.1
				1350	44.4	2.27	36.6	100.4	5.72	6.1	1350	38.8	26.5	0.68	1.95	45.4	19.9	4.4
	11.0	2.8	6.5	1150	44.8	2.36	36.8	106.1	5.57	6.9	1150	38.5	22.7	0.59	1.79	44.6	21.5	3.8
1350				46.6	2.29	38.8	102.0	5.95	6.3	1350	39.7	26.7	0.67	1.87	46.1	21.3	4.2	
90	5.0	0.7	1.7	1150	42.1	2.35	34.1	103.9	5.26	7.2	1150	36.3	21.3	0.59	2.21	43.9	16.4	5.9
				1350	43.7	2.30	35.9	100.0	5.58	6.7	1350	37.5	25.0	0.67	2.30	45.3	16.3	6.2
	8.0	1.6	3.6	1150	45.8	2.36	37.7	106.8	5.68	7.4	1150	36.3	21.5	0.59	2.10	43.5	17.3	5.5
				1350	47.6	2.28	39.9	102.7	6.12	6.9	1350	37.3	25.4	0.68	2.18	44.8	17.2	5.9
	11.0	2.7	6.2	1150	48.3	2.38	40.1	108.9	5.93	7.7	1150	37.3	21.8	0.58	2.01	44.2	18.6	5.1
1350				50.3	2.31	42.4	104.5	6.39	7.1	1350	38.5	25.6	0.66	2.10	45.7	18.3	5.6	
100	5.0	0.7	1.7	Operation not recommended							Operation not recommended							
	8.0	1.5	3.5	Operation not recommended							1150	35.2	22.5	0.64	2.42	43.5	14.6	7.1
				1350	36.3	26.5	0.73	2.51	44.9	14.4	7.7							
	11.0	2.6	6.0	Operation not recommended							1150	36.5	22.8	0.63	2.33	44.5	15.7	6.6
1350				37.6	26.8	0.71	2.43	45.9	15.5	7.3								
110	5.0	0.7	1.6	Operation not recommended							Operation not recommended							
	8.0	1.5	3.4	Operation not recommended							1150	31.6	21.2	0.67	2.69	40.8	11.7	9.0
				1350	32.6	24.9	0.76	2.80	42.2	11.6	9.8							
	11.0	2.5	5.8	Operation not recommended							1150	33.1	21.6	0.65	2.61	42.0	12.7	8.4
1350				34.0	25.3	0.74	2.72	43.3	12.5	9.3								
120	5.0	0.7	1.5	Operation not recommended							Operation not recommended							
	8.0	1.4	3.3	Operation not recommended							1150	29.1	20.6	0.71	3.01	39.4	9.7	11.2
				1350	30.1	24.2	0.80	3.14	40.8	9.6	12.1							
	11.0	2.4	5.6	Operation not recommended							1150	30.8	21.0	0.68	2.92	40.8	10.6	10.4
1350				31.6	24.7	0.78	3.06	42.0	10.3	11.5								

Performance Data cont.

Model 049 - Full Load Dual Capacity with Variable Speed ECM or 5-Speed ECM (1550 cfm)

EWT °F	Flow Rate GPM	WPD		HEATING - EAT 70°F							COOLING - EAT 80/67 °F							
				Airflow CFM	HC MBtu/h	Power kW	HE MBtu/h	LAT °F	COP	HWC Mbtu/h	Airflow CFM	TC Mbtu/h	SC Mbtu/h	S/T Ratio	Power kW	HR Mbtu/h	EER	HWC Mbtu/h
		PSI	FT/HD	Operation not recommended							Operation not recommended							
20	6.0	1.3	3.0	Operation not recommended							Operation not recommended							
	9.0	2.5	5.7	Operation not recommended							Operation not recommended							
	12.0	4.0	9.2	1350	32.6	2.94	22.6	92.4	3.25	5.3	Operation not recommended							
				1550	33.8	2.98	23.6	90.2	3.32	4.8	Operation not recommended							
30	6.0	1.2	2.9	Operation not recommended							Operation not recommended							
	9.0	2.4	5.5	1350	36.2	2.99	26.0	94.8	3.55	5.6	1350	51.5	28.2	0.55	1.80	57.6	28.6	---
				1550	37.3	3.01	27.0	92.3	3.63	5.2	1550	52.3	30.8	0.59	1.89	58.8	27.6	---
	12.0	3.9	8.9	1350	37.1	3.01	26.8	95.4	3.61	5.6	1350	51.7	28.2	0.54	1.74	57.7	29.7	---
				1550	38.4	3.05	28.0	92.9	3.69	5.3	1550	53.0	30.8	0.58	1.83	59.2	29.0	---
40	6.0	1.2	2.8	Operation not recommended							Operation not recommended							
	9.0	2.3	5.3	1350	40.9	3.11	30.3	98.0	3.86	6.2	1350	52.9	29.7	0.56	2.01	59.8	26.3	-
				1550	42.3	3.11	31.7	95.3	3.99	5.7	1550	53.9	32.5	0.60	2.11	61.1	25.6	-
	12.0	3.7	8.7	1350	42.2	3.13	31.5	98.9	3.96	6.4	1350	53.3	29.7	0.56	1.95	60.0	27.3	-
				1550	43.7	3.15	32.9	96.1	4.07	5.8	1550	54.5	32.5	0.60	2.04	61.5	26.7	-
50	6.0	1.2	2.7	1350	42.3	3.12	31.7	99.0	3.98	6.7	1350	52.9	28.8	0.54	2.63	61.8	20.1	3.0
				1550	43.7	3.12	33.0	96.1	4.10	6.2	1550	54.5	34.0	0.62	2.74	63.9	19.9	3.2
	9.0	2.2	5.2	1350	45.6	3.22	34.6	101.3	4.15	6.9	1350	54.0	28.9	0.54	2.27	61.8	23.8	2.8
				1550	47.3	3.20	36.4	98.3	4.34	6.4	1550	55.7	34.1	0.61	2.38	63.8	23.4	3.0
	12.0	3.6	8.4	1350	47.3	3.24	36.3	102.5	4.28	7.2	1350	54.4	28.9	0.53	2.14	61.7	25.4	2.6
1550				48.9	3.24	37.8	99.2	4.42	6.5	1550	56.0	34.1	0.61	2.25	63.7	24.9	2.9	
60	6.0	1.1	2.6	1350	46.3	3.26	35.2	101.8	4.16	7.6	1350	52.5	29.1	0.55	2.78	62.0	18.9	3.7
				1550	48.0	3.24	36.9	98.7	4.34	7.0	1550	54.1	34.3	0.63	2.90	64.0	18.7	3.9
	9.0	2.2	5.0	1350	50.1	3.34	38.7	104.4	4.40	7.8	1350	53.4	29.3	0.55	2.47	61.8	21.6	3.4
				1550	52.1	3.30	40.8	101.1	4.62	7.2	1550	55.0	34.5	0.63	2.58	63.8	21.3	3.7
	12.0	3.5	8.1	1350	52.2	3.37	40.7	105.8	4.54	8.0	1350	54.0	29.4	0.55	2.34	61.9	23.0	3.2
1550				54.1	3.33	42.7	102.3	4.76	7.4	1550	55.6	34.6	0.62	2.45	63.9	22.7	3.5	
70	6.0	1.1	2.5	1350	50.4	3.40	38.8	104.5	4.34	8.5	1350	52.1	29.4	0.56	2.94	62.1	17.7	4.6
				1550	52.3	3.36	40.9	101.3	4.56	7.9	1550	53.7	34.6	0.64	3.07	64.2	17.5	4.9
	9.0	2.1	4.9	1350	54.7	3.46	42.9	107.5	4.63	8.8	1350	52.6	29.7	0.56	2.66	61.7	19.8	4.3
				1550	56.8	3.40	45.2	103.9	4.90	8.1	1550	54.3	34.9	0.64	2.78	63.8	19.5	4.6
	12.0	3.4	7.9	1350	57.2	3.50	45.2	109.2	4.79	9.0	1350	53.6	29.9	0.56	2.54	62.2	21.1	4.0
1550				59.3	3.42	47.6	105.4	5.08	8.3	1550	55.2	35.1	0.64	2.64	64.2	20.9	4.4	
80	6.0	1.1	2.5	1350	54.3	3.56	42.2	107.2	4.47	9.6	1350	49.7	28.5	0.57	3.11	60.3	16.0	5.8
				1550	56.4	3.50	44.5	103.7	4.73	8.8	1550	51.3	33.5	0.65	3.25	62.3	15.8	6.2
	9.0	2.0	4.7	1350	59.0	3.60	46.7	110.5	4.80	9.8	1350	50.0	28.8	0.58	2.89	59.8	17.3	5.4
				1550	61.4	3.51	49.4	106.7	5.13	9.1	1550	51.4	33.9	0.66	3.01	61.7	17.1	5.9
	12.0	3.3	7.6	1350	62.0	3.64	49.6	112.5	4.99	10.1	1350	51.1	29.1	0.57	2.77	60.5	18.5	5.0
1550				64.5	3.54	52.4	108.5	5.34	9.4	1550	52.7	34.2	0.65	2.88	62.5	18.3	5.6	
90	6.0	1.0	2.4	1350	58.2	3.72	45.6	109.9	4.59	10.7	1350	47.3	27.6	0.58	3.30	58.5	14.3	7.3
				1550	60.5	3.63	48.1	106.1	4.88	9.9	1550	48.8	32.4	0.66	3.43	60.5	14.2	7.7
	9.0	2.0	4.5	1350	63.3	3.74	50.6	113.4	4.97	11.1	1350	47.3	27.9	0.59	3.13	57.9	15.1	6.8
				1550	65.9	3.61	53.6	109.4	5.35	10.2	1550	48.6	32.9	0.68	3.24	59.6	15.0	7.4
	12.0	3.2	7.3	1350	66.8	3.78	53.9	115.8	5.18	11.4	1350	48.6	28.2	0.58	2.99	58.8	16.2	6.3
1550				69.6	3.66	57.1	111.6	5.58	10.6	1550	50.1	33.2	0.66	3.13	60.8	16.0	7.0	
100	6.0	1.0	2.3	Operation not recommended							Operation not recommended							
	9.0	1.9	4.4	Operation not recommended							1350	44.3	27.1	0.61	3.49	56.2	12.7	8.4
				1550	45.6	31.9	0.70	3.62	58.0	12.6	9.2	1350	45.9	27.5	0.60	3.36	57.4	13.7
	12.0	3.1	7.1	Operation not recommended							1550	47.3	32.3	0.68	3.51	59.2	13.5	8.7
				Operation not recommended							1350	41.2	26.3	0.64	3.85	54.4	10.7	10.3
110	6.0	1.0	2.2	Operation not recommended							Operation not recommended							
	9.0	1.8	4.2	Operation not recommended							1350	42.6	30.9	0.73	4.01	56.3	10.6	11.2
				1550	43.2	26.8	0.62	3.73	55.9	11.6	9.6	1350	44.4	31.4	0.71	3.89	57.7	11.4
	12.0	2.9	6.8	Operation not recommended							1550	44.4	31.4	0.71	3.89	57.7	11.4	10.7
Operation not recommended							1350	40.1	27.7	0.69	4.35	54.9	9.2	12.5				
120	6.0	0.9	2.1	Operation not recommended							Operation not recommended							
	9.0	1.7	4.0	Operation not recommended							1350	40.1	27.7	0.69	4.35	54.9	9.2	12.5
				1550	40.8	30.1	0.74	4.46	56.0	9.1	13.5	1350	40.4	27.7	0.69	4.21	54.8	9.6
	12.0	2.8	6.5	Operation not recommended							1550	41.3	30.1	0.73	4.34	56.1	9.5	12.9
Operation not recommended							1350	40.4	27.7	0.69	4.21	54.8	9.6	11.6				

Performance Data cont.

Model 064 - Part Load Dual Capacity with Variable Speed ECM or 5-Speed ECM (1500 cfm)

EWT °F	Flow Rate GPM	WPD		HEATING - EAT 70°F							COOLING - EAT 80/67 °F							
				Airflow CFM	HC MBtu/h	Power kW	HE MBtu/h	LAT °F	COP	HWC Mbtu/h	Airflow CFM	TC Mbtu/h	SC Mbtu/h	S/T Ratio	Power kW	HR Mbtu/h	EER	HWC Mbtu/h
		PSI	FT/HD	Operation not recommended							Operation not recommended							
20	6.0	1.0	2.4	Operation not recommended							Operation not recommended							
	10.0	2.7	6.2	Operation not recommended							Operation not recommended							
	14.0	5.1	11.8	1250	28.6	2.73	19.3	91.2	3.07	4.9	Operation not recommended							
				1500	29.6	2.77	20.1	88.3	3.13	4.5	Operation not recommended							
30	6.0	1.0	2.3	Operation not recommended							Operation not recommended							
	10.0	2.6	6.0	1250	31.9	2.70	22.7	93.6	3.46	5.0	1250	50.0	30.0	0.60	1.38	54.7	36.3	-
				1500	33.1	2.74	23.7	90.4	3.54	4.6	1500	50.8	32.8	0.65	1.45	55.8	35.0	-
	14.0	5.0	11.5	1250	33.1	2.70	23.8	94.5	3.58	5.1	1250	50.3	30.0	0.60	1.34	54.8	37.6	-
1500				34.2	2.74	24.9	91.1	3.66	4.7	1500	51.5	32.8	0.64	1.40	56.3	36.7	-	
40	6.0	1.0	2.3	Operation not recommended							Operation not recommended							
	10.0	2.5	5.9	1250	37.4	2.79	27.9	97.7	3.92	5.3	1250	51.5	30.7	0.60	1.54	56.8	33.5	-
				1500	38.4	2.80	28.9	93.7	4.02	4.9	1500	52.5	33.6	0.64	1.61	58.0	32.5	-
	14.0	4.8	11.1	1250	38.6	2.80	29.1	98.6	4.04	5.5	1250	51.9	30.7	0.59	1.49	57.0	34.8	-
1500				39.7	2.81	30.1	94.5	4.14	5.0	1500	53.1	33.6	0.63	1.56	58.4	34.0	-	
50	6.0	0.9	2.2	1250	42.2	2.83	32.5	101.2	4.37	5.6	1250	52.8	30.0	0.57	1.74	58.7	30.4	2.0
				1500	43.3	2.83	33.7	96.7	4.49	5.2	1500	54.3	34.0	0.63	1.83	60.6	29.7	2.1
	10.0	2.5	5.7	1250	42.8	2.88	33.0	101.7	4.36	5.7	1250	52.9	30.2	0.57	1.67	58.7	31.7	1.9
				1500	43.8	2.86	34.0	97.0	4.48	5.3	1500	54.5	34.3	0.63	1.75	60.5	31.1	2.0
	14.0	4.7	10.8	1250	44.1	2.90	34.2	102.7	4.46	5.9	1250	53.1	30.2	0.57	1.64	58.7	32.3	1.7
				1500	45.1	2.88	35.3	97.8	4.59	5.4	1500	54.6	34.3	0.63	1.72	60.5	31.8	1.9
60	6.0	0.9	2.1	1250	46.6	2.91	36.7	104.5	4.70	6.1	1250	51.4	29.8	0.58	1.96	58.1	26.2	2.8
				1500	47.6	2.89	37.8	99.4	4.84	5.7	1500	53.0	33.7	0.64	2.06	60.0	25.8	3.0
	10.0	2.4	5.5	1250	48.1	2.96	38.0	105.6	4.76	6.3	1250	51.6	30.1	0.58	1.90	58.1	27.2	2.6
				1500	48.9	2.92	38.9	100.2	4.90	5.8	1500	53.2	34.0	0.64	1.99	60.0	26.8	2.9
	14.0	4.5	10.4	1250	49.2	2.99	39.0	106.5	4.83	6.5	1250	51.9	30.2	0.58	1.86	58.2	27.9	2.5
				1500	50.0	2.95	40.0	100.9	4.98	6.0	1500	53.4	34.1	0.64	1.95	60.1	27.4	2.7
70	6.0	0.9	2.0	1250	51.1	2.99	40.9	107.9	5.01	6.8	1250	50.0	29.7	0.59	2.19	57.5	22.9	4.0
				1500	52.0	2.94	42.0	102.1	5.18	6.3	1500	51.6	33.3	0.64	2.28	59.4	22.6	4.2
	10.0	2.3	5.3	1250	53.3	3.04	42.9	109.5	5.13	7.0	1250	50.3	29.9	0.59	2.13	57.6	23.7	3.7
				1500	53.9	2.98	43.7	103.3	5.31	6.5	1500	51.9	33.7	0.65	2.22	59.5	23.4	4.0
	14.0	4.4	10.1	1250	54.3	3.08	43.8	110.2	5.17	7.2	1250	50.7	30.1	0.59	2.08	57.8	24.3	3.5
				1500	54.9	3.01	44.6	103.9	5.35	6.6	1500	52.2	33.8	0.65	2.17	59.6	24.0	3.9
80	6.0	0.9	2.0	1250	55.4	3.09	44.9	111.0	5.26	7.6	1250	47.2	28.5	0.60	2.49	55.7	18.9	5.5
				1500	55.9	3.02	45.6	104.5	5.43	7.0	1500	48.6	31.8	0.65	2.58	57.4	18.9	5.9
	10.0	2.2	5.1	1250	58.5	3.14	47.8	113.4	5.47	7.8	1250	47.6	28.7	0.60	2.43	55.9	19.6	5.2
				1500	58.8	3.04	48.4	106.3	5.66	7.2	1500	49.0	32.2	0.66	2.52	57.6	19.4	5.6
	14.0	4.2	9.8	1250	59.2	3.18	48.4	113.9	5.46	8.0	1250	47.9	28.9	0.60	2.39	56.0	20.0	4.8
				1500	59.5	3.09	48.9	106.7	5.65	7.4	1500	49.4	32.4	0.65	2.48	57.8	19.9	5.3
90	6.0	0.8	1.9	1250	59.7	3.18	48.9	114.2	5.51	8.5	1250	44.3	27.2	0.61	2.80	53.8	15.8	7.4
				1500	59.8	3.09	49.3	106.9	5.67	7.8	1500	45.6	30.2	0.66	2.88	55.4	15.9	7.8
	10.0	2.1	5.0	1250	63.7	3.23	52.7	117.2	5.79	8.7	1250	44.8	27.5	0.61	2.73	54.1	16.4	6.9
				1500	63.7	3.11	53.1	109.3	6.01	8.1	1500	46.1	30.6	0.66	2.83	55.8	16.3	7.5
	14.0	4.1	9.4	1250	64.1	3.28	53.0	117.5	5.74	9.0	1250	45.1	27.8	0.62	2.70	54.3	16.7	6.4
				1500	64.0	3.16	53.2	109.5	5.94	8.3	1500	46.6	30.9	0.66	2.78	56.1	16.8	7.1
100	6.0	0.8	1.8	Operation not recommended							Operation not recommended							
	10.0	2.1	4.8	1250	41.7	26.8	0.64	3.13	52.4	13.3	9.0	Operation not recommended						
				1500	43.0	29.6	0.69	3.22	54.0	13.4	9.7	Operation not recommended						
	14.0	3.9	9.1	1250	42.2	27.1	0.64	3.09	52.7	13.6	8.3	Operation not recommended						
1500				43.5	30.0	0.69	3.17	54.3	13.7	9.2	Operation not recommended							
110	6.0	0.8	1.8	Operation not recommended							Operation not recommended							
	10.0	2.0	4.6	1250	38.7	26.0	0.67	3.53	50.7	10.9	11.3	Operation not recommended						
				1500	39.9	28.6	0.72	3.60	52.2	11.1	12.3	Operation not recommended						
	14.0	3.8	8.7	1250	39.2	26.4	0.67	3.48	51.1	11.3	10.5	Operation not recommended						
1500				40.4	29.0	0.72	3.55	52.5	11.4	11.7	Operation not recommended							
120	6.0	0.7	1.7	Operation not recommended							Operation not recommended							
	10.0	1.9	4.4	1250	36.7	26.7	0.73	4.01	50.4	9.2	14.0	Operation not recommended						
				1500	37.4	29.0	0.78	4.11	51.4	9.1	15.2	Operation not recommended						
	14.0	3.6	8.4	1250	37.0	26.7	0.72	3.88	50.2	9.5	13.0	Operation not recommended						
1500				37.8	29.0	0.77	4.00	51.4	9.5	14.5	Operation not recommended							

Performance Data cont.

Model 064 - Full Load Dual Capacity with Variable Speed ECM or 5-Speed ECM (1800 cfm)

EWT °F	Flow Rate GPM	WPD		HEATING - EAT 70°F							COOLING - EAT 80/67 °F								
				Airflow	HC	Power	HE	LAT	COP	HWC	Airflow	TC	SC	S/T	Power	HR	EER	HWC	
		CFM	MBtu/h	kW	MBtu/h	°F		Mbtu/h	CFM	Mbtu/h	Mbtu/h	Ratio	kW	Mbtu/h		Mbtu/h			
20	8.0	1.8	4.2	Operation not recommended							Operation not recommended								
	12.0	3.8	8.8	Operation not recommended							Operation not recommended								
	16.0	6.5	15.1	1500	39.7	3.44	28.0	94.5	3.39	6.2	Operation not recommended								
				1800	40.7	3.60	28.4	90.9	3.31	5.6	Operation not recommended								
30	8.0	1.8	4.1	Operation not recommended							Operation not recommended								
	12.0	3.7	8.6	1500	45.8	3.46	34.1	98.3	3.89	6.5	1500	64.3	41.0	0.64	2.29	72.1	28.1	---	
				1800	47.1	3.68	34.6	94.2	3.75	6.0	1800	65.3	44.8	0.62	2.41	73.5	27.1	---	
	16.0	6.4	14.7	1500	46.5	3.54	34.4	98.7	3.84	6.7	1500	64.6	41.0	0.63	2.22	72.2	29.1	---	
				1800	47.6	3.71	34.9	94.5	3.76	6.1	1800	66.2	44.8	0.68	2.33	74.1	28.4	---	
40	8.0	1.7	4.0	Operation not recommended							Operation not recommended								
	12.0	3.6	8.3	1500	52.7	3.68	40.1	102.5	4.19	7.2	1500	66.8	41.9	0.63	2.66	75.9	25.1	---	
				1800	53.9	3.84	40.8	97.7	4.11	6.6	1800	68.1	45.8	0.67	2.79	77.6	24.4	---	
	16.0	6.2	14.2	1500	53.5	3.75	40.7	103.0	4.18	7.4	1500	67.4	41.9	0.62	2.58	76.2	26.1	---	
				1800	54.7	3.88	41.5	98.1	4.13	6.7	1800	68.9	45.8	0.66	2.70	78.1	25.5	---	
50	8.0	1.7	3.8	1500	56.3	3.84	43.2	104.7	4.30	7.8	1500	68.7	42.2	0.61	3.00	78.9	22.9	4.0	
				1800	57.4	3.95	44.0	99.6	4.26	7.2	1800	70.1	45.9	0.65	3.19	81.0	22.0	4.2	
	12.0	3.5	8.1	1500	59.5	3.91	46.2	106.7	4.46	8.0	1500	69.4	42.6	0.61	2.94	79.4	23.6	3.7	
				1800	60.7	4.01	47.0	101.2	4.44	7.4	1800	70.8	46.4	0.65	3.12	81.5	22.7	4.0	
	16.0	6.0	13.8	1500	60.5	3.95	47.0	107.3	4.48	8.2	1500	70.1	43.1	0.61	2.89	80.0	24.3	3.4	
			1800	61.8	4.05	48.0	101.8	4.47	7.5	1800	71.5	46.8	0.65	3.07	82.0	23.3	3.8		
60	8.0	1.6	3.7	1500	63.1	4.12	49.1	109.0	4.49	8.7	1500	68.2	42.2	0.62	3.30	79.5	20.7	4.8	
				1800	64.5	4.18	50.2	103.2	4.52	8.0	1800	70.0	45.9	0.66	3.51	81.9	19.9	5.1	
	12.0	3.4	7.8	1500	66.0	4.18	51.7	110.7	4.62	9.0	1500	68.9	42.6	0.62	3.23	79.9	21.3	4.5	
				1800	67.4	4.24	53.0	104.7	4.66	8.3	1800	70.7	46.3	0.66	3.43	82.4	20.6	4.9	
	16.0	5.8	13.4	1500	67.4	4.23	53.0	111.6	4.67	9.2	1500	69.6	43.1	0.62	3.18	80.4	21.9	4.2	
			1800	69.0	4.28	54.3	105.5	4.72	8.5	1800	71.4	46.8	0.66	3.38	82.9	21.1	4.6		
70	8.0	1.6	3.6	1500	69.9	4.39	55.0	113.2	4.66	9.8	1500	67.7	42.2	0.62	3.60	80.0	18.8	6.1	
				1800	71.5	4.42	56.4	106.8	4.74	9.0	1800	69.8	45.9	0.66	3.83	82.9	18.2	6.4	
	12.0	3.3	7.5	1500	72.5	4.46	57.3	114.8	4.77	10.1	1500	68.4	42.6	0.62	3.53	80.4	19.4	5.7	
				1800	74.2	4.47	58.9	108.1	4.86	9.3	1800	70.6	46.3	0.66	3.75	83.4	18.8	6.1	
	16.0	5.6	12.9	1500	74.4	4.51	59.0	115.9	4.83	10.4	1500	69.0	43.0	0.62	3.46	80.9	19.9	5.3	
			1800	76.1	4.51	60.7	109.1	4.95	9.6	1800	71.2	46.8	0.66	3.69	83.8	19.3	5.8		
80	8.0	1.5	3.5	1500	76.9	4.70	60.9	117.5	4.80	11.0	1500	63.2	40.8	0.65	3.89	76.5	16.3	7.7	
				1800	78.7	4.67	62.7	110.5	4.94	10.2	1800	65.5	44.3	0.68	4.14	79.7	15.8	8.1	
	12.0	3.2	7.3	1500	78.7	4.76	62.5	118.6	4.85	11.3	1500	63.9	41.1	0.64	3.81	76.9	16.8	7.1	
				1800	80.6	4.71	64.6	111.5	5.02	10.5	1800	66.2	44.7	0.68	4.06	80.0	16.3	7.7	
	16.0	5.4	12.5	1500	81.1	4.81	64.7	120.1	4.94	11.7	1500	64.5	41.6	0.65	3.75	77.3	17.2	6.6	
			1800	83.2	4.76	66.9	112.8	5.13	10.8	1800	66.9	45.2	0.68	3.99	80.5	16.8	7.4		
90	8.0	1.4	3.3	1500	83.9	5.00	66.8	121.8	4.92	12.4	1500	58.7	39.3	0.67	4.18	72.9	14.0	9.6	
				1800	85.9	4.93	69.1	114.2	5.11	11.4	1800	61.3	42.7	0.70	4.45	76.5	13.8	10.2	
	12.0	3.0	7.0	1500	85.0	5.05	67.7	122.5	4.93	12.7	1500	59.3	39.6	0.67	4.10	73.3	14.5	9.0	
				1800	87.1	4.95	70.2	114.8	5.16	11.8	1800	61.8	43.1	0.70	4.36	76.7	14.2	9.7	
	16.0	5.2	12.0	1500	87.9	5.12	70.4	124.3	5.03	13.1	1500	59.9	40.1	0.67	4.03	73.7	14.9	8.3	
			1800	90.2	5.00	73.1	116.4	5.29	12.2	1800	62.5	43.5	0.70	4.29	77.2	14.6	9.2		
100	8.0	1.4	3.2	Operation not recommended							Operation not recommended								
	12.0	2.9	6.8	Operation not recommended							Operation not recommended								
				1500	55.2	37.5	0.68	4.47	70.4	12.3	11.1	1500	55.2	37.5	0.68	4.47	70.4	12.3	11.1
	16.0	5.0	11.6	1800	57.8	40.7	0.70	4.77	74.0	12.1	12.1	1800	57.8	40.7	0.70	4.77	74.0	12.1	12.1
110	8.0	1.3	3.1	Operation not recommended							Operation not recommended								
	12.0	2.8	6.5	Operation not recommended							Operation not recommended								
				1500	51.0	35.3	0.69	4.84	67.5	10.5	13.6	1500	51.0	35.3	0.69	4.84	67.5	10.5	13.6
	16.0	4.8	11.2	1800	53.7	38.3	0.71	5.17	71.4	10.4	14.8	1800	53.7	38.3	0.71	5.17	71.4	10.4	14.8
120	8.0	1.3	3.0	Operation not recommended							Operation not recommended								
	12.0	2.7	6.3	Operation not recommended							Operation not recommended								
				1500	51.4	36.4	0.71	5.62	70.6	9.2	16.5	1500	51.4	36.4	0.71	5.62	70.6	9.2	16.5
	16.0	4.6	10.7	1800	52.4	39.5	0.75	5.76	72.0	9.1	17.9	1800	51.9	36.4	0.70	5.44	70.4	9.5	15.3
			1800	53.0	39.5	0.75	5.61	72.1	9.4	17.0	Operation not recommended								

Performance Data cont.

Model 072 - Part Load Dual Capacity with Variable Speed ECM or 5-Speed ECM (1700 cfm)

EWT °F	Flow Rate GPM	WPD		HEATING - EAT 70°F							COOLING - EAT 80/67 °F							
				Airflow CFM	HC MBtu/h	Power kW	HE MBtu/h	LAT °F	COP	HWC Mbtu/h	Airflow CFM	TC Mbtu/h	SC Mbtu/h	S/T Ratio	Power kW	HR Mbtu/h	EER	HWC Mbtu/h
		PSI	FT/HD	Operation not recommended							Operation not recommended							
20	10.0	2.3	5.4	Operation not recommended							Operation not recommended							
	13.0	3.6	8.2	Operation not recommended							Operation not recommended							
	16.0	5.0	11.6	1400	37.2	3.74	24.4	94.6	2.91	6.0	Operation not recommended							
				1700	39.0	3.79	26.0	91.2	3.02	5.4	Operation not recommended							
30	10.0	2.3	5.3	Operation not recommended							Operation not recommended							
	13.0	3.5	8.0	1400	41.0	3.81	28.0	97.1	3.15	6.1	1400	54.1	34.6	0.64	1.81	60.3	29.9	---
				1700	43.0	3.86	29.8	93.4	3.27	5.6	1700	55.0	37.8	0.69	1.91	61.5	28.8	---
	16.0	4.9	11.3	1400	42.8	3.81	29.8	98.3	3.29	6.3	1400	54.4	34.6	0.64	1.76	60.4	30.9	---
				1700	44.8	3.86	31.6	94.4	3.40	5.7	1700	55.7	37.8	0.68	1.85	62.0	30.2	---
	40	10.0	2.2	5.1	Operation not recommended							Operation not recommended						
13.0		3.4	7.8	1400	47.6	3.92	34.2	101.5	3.56	6.5	1400	56.7	36.5	0.64	2.02	63.6	28.0	---
				1700	49.7	3.93	36.3	97.1	3.71	5.9	1700	57.8	39.8	0.69	2.12	65.0	27.2	---
16.0		4.7	11.0	1400	49.3	3.93	35.9	102.6	3.68	6.7	1400	57.2	36.5	0.64	1.96	63.9	29.1	---
				1700	51.5	3.94	38.0	98.0	3.83	6.1	1700	58.5	39.8	0.68	2.05	65.5	28.5	---
50		10.0	2.1	4.9	1400	53.4	3.98	39.8	105.3	3.93	6.8	1400	59.1	36.5	0.62	2.28	66.9	25.9
	1700				55.8	3.94	42.3	100.4	4.15	6.3	1700	60.9	41.4	0.68	2.40	69.1	25.4	2.4
	13.0	3.3	7.5	1400	54.2	4.02	40.5	105.8	3.95	7.0	1400	59.2	36.8	0.62	2.20	66.7	26.9	2.1
				1700	56.4	4.00	42.7	100.7	4.13	6.4	1700	61.0	41.8	0.68	2.32	69.0	26.3	2.3
	16.0	4.6	10.6	1400	55.8	4.04	42.0	106.9	4.04	7.2	1400	59.4	36.8	0.62	2.14	66.7	27.7	2.0
				1700	58.1	4.02	44.4	101.7	4.24	6.6	1700	61.2	41.8	0.68	2.26	68.9	27.1	2.2
60	10.0	2.1	4.8	1400	59.5	4.11	45.5	109.3	4.25	7.5	1400	58.1	36.5	0.63	2.54	66.8	22.8	3.2
				1700	62.0	4.02	48.3	103.8	4.52	6.9	1700	59.8	41.3	0.69	2.66	68.9	22.5	3.4
	13.0	3.2	7.3	1400	61.1	4.15	47.0	110.4	4.32	7.7	1400	58.3	36.9	0.63	2.46	66.7	23.7	3.0
				1700	63.6	4.07	49.7	104.6	4.57	7.1	1700	60.1	41.7	0.69	2.57	68.9	23.4	3.2
	16.0	4.4	10.3	1400	62.5	4.19	48.2	111.4	4.37	7.9	1400	58.6	37.0	0.63	2.41	66.8	24.3	2.8
				1700	65.0	4.12	51.0	105.4	4.63	7.3	1700	60.4	41.8	0.69	2.52	69.0	24.0	3.1
70	10.0	2.0	4.6	1400	65.6	4.23	51.1	113.4	4.54	8.3	1400	57.1	36.6	0.64	2.81	66.7	20.4	4.5
				1700	68.2	4.11	54.2	107.2	4.87	7.7	1700	58.8	41.2	0.70	2.91	68.7	20.2	4.8
	13.0	3.0	7.0	1400	68.1	4.27	53.5	115.0	4.67	8.5	1400	57.4	37.0	0.64	2.72	66.7	21.2	4.2
				1700	70.7	4.15	56.6	108.5	5.00	7.9	1700	59.1	41.6	0.70	2.82	68.7	20.9	4.5
	16.0	4.3	9.9	1400	69.3	4.34	54.5	115.8	4.68	8.8	1400	57.8	37.2	0.64	2.68	66.9	21.6	3.9
				1700	72.0	4.21	57.6	109.2	5.01	8.1	1700	59.6	41.8	0.70	2.77	69.1	21.5	4.3
80	10.0	1.9	4.5	1400	71.4	4.32	56.7	117.2	4.84	9.2	1400	53.4	35.3	0.66	3.12	64.1	17.1	6.2
				1700	74.0	4.17	59.8	110.3	5.21	8.5	1700	54.8	39.5	0.72	3.21	65.7	17.1	6.6
	13.0	2.9	6.8	1400	75.2	4.37	60.3	119.7	5.04	9.5	1400	53.6	35.7	0.67	3.04	64.0	17.6	5.8
				1700	77.9	4.20	63.6	112.4	5.44	8.8	1700	55.2	39.9	0.72	3.13	65.9	17.6	6.3
	16.0	4.2	9.6	1400	76.0	4.43	60.9	120.3	5.03	9.8	1400	54.0	35.9	0.66	2.99	64.2	18.0	5.4
				1700	78.7	4.27	64.1	112.8	5.40	9.1	1700	56.0	40.2	0.72	3.08	66.4	18.2	6.0
90	10.0	1.9	4.3	1400	77.3	4.41	62.2	121.1	5.14	10.3	1400	49.7	34.0	0.68	3.43	61.4	14.5	8.3
				1700	79.8	4.23	65.4	113.5	5.54	9.5	1700	51.3	37.7	0.74	3.50	63.2	14.6	8.8
	13.0	2.8	6.6	1400	82.3	4.47	67.0	124.4	5.39	10.6	1400	50.2	34.3	0.68	3.36	61.7	14.9	7.7
				1700	85.0	4.25	70.5	116.3	5.87	9.8	1700	51.8	38.2	0.74	3.43	63.5	15.1	8.4
	16.0	4.0	9.3	1400	82.8	4.53	67.3	124.7	5.36	11.0	1400	50.7	34.6	0.68	3.31	62.0	15.3	7.2
				1700	85.4	4.33	70.6	116.5	5.78	10.2	1700	52.3	38.5	0.74	3.38	63.8	15.5	8.0
100	10.0	1.8	4.2	Operation not recommended							Operation not recommended							
	13.0	2.7	6.3	1400	46.9	33.3	0.71	3.83	60.0	12.3	10.0	Operation not recommended						
				1700	48.5	36.9	0.76	3.88	61.7	12.5	10.9	Operation not recommended						
	16.0	3.9	8.9	1400	47.6	33.7	0.71	3.77	60.4	12.6	9.3	Operation not recommended						
1700				49.0	37.3	0.76	3.82	62.0	12.8	10.4	Operation not recommended							
110	10.0	1.7	4.0	Operation not recommended							Operation not recommended							
	13.0	2.6	6.1	1400	43.7	32.2	0.74	4.30	58.3	10.2	12.7	Operation not recommended						
				1700	45.1	35.5	0.79	4.32	59.9	10.5	13.8	Operation not recommended						
	16.0	3.7	8.6	1400	44.4	32.7	0.74	4.24	58.9	10.5	11.8	Operation not recommended						
1700				45.7	36.0	0.79	4.26	60.2	10.7	13.1	Operation not recommended							
120	10.0	1.7	3.8	Operation not recommended							Operation not recommended							
	13.0	2.5	5.8	1400	40.8	32.1	0.79	4.71	56.8	8.7	15.8	Operation not recommended						
				1700	41.5	34.8	0.84	4.83	58.0	8.6	17.1	Operation not recommended						
	16.0	3.6	8.2	1400	41.1	32.1	0.78	4.56	56.7	9.0	14.6	Operation not recommended						
1700				42.0	34.8	0.83	4.70	58.0	8.9	16.3	Operation not recommended							

Performance Data cont.

Model 072 - Full Load Dual Capacity with Variable Speed ECM or 5-Speed ECM (2200 cfm)

EWT °F	Flow Rate GPM	WPD		HEATING - EAT 70°F							COOLING - EAT 80/67 °F												
				Airflow CFM	HC MBtu/h	Power kW	HE MBtu/h	LAT °F	COP	HWC Mbtu/h	Airflow CFM	TC Mbtu/h	SC Mbtu/h	S/T Ratio	Power kW	HR Mbtu/h	EER	HWC Mbtu/h					
		PSI	FT/HD	Operation not recommended							Operation not recommended												
20	12.0	3.3	7.6	Operation not recommended							Operation not recommended												
	15.0	4.7	10.8	Operation not recommended							Operation not recommended												
	18.0	6.2	14.3	1850	50.9	4.60	35.2	95.5	3.24	7.9	2200	52.8	4.90	36.1	92.2	3.16	7.1	Operation not recommended					
30	12.0	3.2	7.4	Operation not recommended							Operation not recommended												
	15.0	4.5	10.5	1850	57.3	4.74	41.2	98.7	3.55	8.3	1850	70.4	43.1	0.61	2.57	79.2	27.4	---					
				2200	59.3	5.04	42.1	95.0	3.45	7.6	2200	71.5	47.1	0.66	2.71	80.8	26.4	---					
	18.0	6.0	13.9	1850	57.8	4.78	41.5	98.9	3.54	8.6	1850	70.8	43.1	0.61	2.50	79.3	28.4	---					
				2200	59.9	5.09	42.6	95.2	3.45	7.8	2200	72.5	47.1	0.65	2.62	81.4	27.7	---					
40	12.0	3.1	7.1	Operation not recommended							Operation not recommended												
	15.0	4.4	10.2	1850	65.0	4.97	48.0	102.5	3.83	9.2	1850	72.9	45.8	0.63	3.15	83.6	23.2	---					
				2200	67.2	5.21	49.4	98.3	3.78	8.4	2200	74.3	50.0	0.67	3.30	85.5	22.5	---					
	18.0	5.8	13.5	1850	65.9	5.03	48.8	103.0	3.84	9.5	1850	73.5	45.8	0.62	3.06	83.9	24.0	---					
				2200	68.2	5.26	50.2	98.7	3.80	8.6	2200	75.1	50.0	0.67	3.20	86.0	23.5	---					
50	12.0	3.0	6.9	1850	68.8	5.10	51.4	104.4	3.95	9.9	1850	74.6	47.6	0.64	3.68	87.2	20.3	4.3					
				2200	71.1	5.28	53.1	99.9	3.94	9.2	2200	76.2	51.7	0.68	3.91	89.6	19.5	4.6					
	15.0	4.3	9.9	1850	72.7	5.20	54.9	106.4	4.10	10.3	1850	75.4	48.1	0.64	3.60	87.7	20.9	4.0					
				2200	75.1	5.37	56.8	101.6	4.10	9.4	2200	76.9	52.3	0.68	3.83	90.0	20.1	4.4					
	18.0	5.7	13.1	1850	74.0	5.26	56.0	107.0	4.12	10.6	1850	76.2	49.1	0.64	3.54	88.3	21.5	3.7					
				2200	76.4	5.42	57.9	102.2	4.13	9.7	2200	77.7	52.8	0.68	3.77	90.6	20.6	4.2					
60	12.0	2.9	6.7	1850	77.2	5.40	58.8	108.6	4.19	11.1	1850	74.0	48.1	0.65	4.01	87.7	18.4	5.3					
				2200	79.7	5.50	60.9	103.5	4.24	10.3	2200	75.5	52.0	0.69	4.26	90.1	17.7	5.6					
	15.0	4.1	9.6	1850	80.6	5.49	61.9	110.3	4.30	11.5	1850	74.7	48.6	0.65	3.93	88.1	19.0	4.9					
				2200	83.2	5.58	64.2	105.0	4.37	10.6	2200	76.2	52.5	0.69	4.17	90.5	18.3	5.3					
	18.0	5.5	12.7	1850	82.4	5.56	63.4	111.2	4.35	11.8	1850	75.5	49.4	0.65	3.86	88.7	19.6	4.6					
				2200	85.1	5.63	65.9	105.8	4.43	10.9	2200	77.1	53.1	0.69	4.11	91.1	18.7	5.1					
70	12.0	2.8	6.5	1850	85.5	5.68	66.1	112.8	4.41	12.5	1850	73.3	48.6	0.66	4.34	88.2	16.9	6.6					
				2200	88.2	5.72	68.7	107.1	4.52	11.6	2200	74.9	52.3	0.70	4.62	90.6	16.2	7.0					
	15.0	4.0	9.2	1850	88.5	5.77	68.8	114.3	4.49	12.9	1850	74.1	49.1	0.66	4.25	88.6	17.4	6.2					
				2200	91.3	5.78	71.6	108.4	4.63	11.9	2200	75.6	52.8	0.70	4.52	91.0	16.7	6.7					
	18.0	5.3	12.2	1850	90.8	5.85	70.9	115.4	4.55	13.3	1850	74.9	49.6	0.66	4.18	89.1	17.9	5.7					
				2200	93.8	5.85	73.9	109.5	4.70	12.3	2200	76.4	53.4	0.70	4.45	91.6	17.2	6.4					
80	12.0	2.7	6.3	1850	93.6	6.03	73.0	116.9	4.55	14.1	1850	69.6	46.8	0.67	4.63	85.4	15.0	8.4					
				2200	96.6	5.98	76.2	110.7	4.73	13.0	2200	71.1	50.6	0.71	4.92	87.9	14.4	8.9					
	15.0	3.9	8.9	1850	95.8	6.11	75.0	118.0	4.60	14.5	1850	70.3	47.3	0.67	4.53	85.8	15.5	7.8					
				2200	98.9	6.03	78.3	111.6	4.81	13.4	2200	71.8	51.0	0.71	4.82	88.2	14.9	8.4					
	18.0	5.1	11.8	1850	98.7	6.19	77.6	119.4	4.68	15.0	1850	71.1	48.0	0.67	4.46	86.3	16.0	7.2					
				2200	102.0	6.09	81.2	112.9	4.91	13.8	2200	72.5	51.6	0.71	4.75	88.7	15.3	8.0					
90	12.0	2.6	6.0	1850	101.7	6.37	79.9	120.9	4.68	15.8	1850	65.9	45.0	0.68	4.92	82.7	13.4	10.5					
				2200	105.0	6.24	83.7	114.2	4.93	14.7	2200	67.3	48.9	0.73	5.23	85.2	12.9	11.1					
	15.0	3.7	8.6	1850	103.1	6.44	81.1	121.6	4.69	16.3	1850	66.6	45.4	0.68	4.81	83.0	13.8	9.8					
				2200	106.5	6.27	85.0	114.8	4.97	15.1	2200	67.9	49.3	0.73	5.13	85.4	13.3	10.6					
	18.0	4.9	11.4	1850	106.7	6.53	84.4	123.4	4.79	16.8	1850	67.3	46.3	0.69	4.73	83.5	14.2	9.1					
				2200	110.2	6.34	88.6	116.4	5.09	15.6	2200	68.7	49.8	0.73	5.04	85.9	13.6	10.1					
100	12.0	2.5	5.8	Operation not recommended							Operation not recommended												
	15.0	3.6	8.3	1850	63.2	44.4	0.70	5.29	81.2	12.0	12.2	1850	63.2	44.4	0.70	5.29	81.2	12.0	12.2				
				2200	64.5	48.0	0.74	5.63	83.7	11.5	13.2	2200	64.5	48.0	0.74	5.63	83.7	11.5	13.2				
	18.0	4.8	11.0	1850	63.9	45.1	0.71	5.20	81.6	12.3	11.3	1850	63.9	45.1	0.71	5.20	81.6	12.3	11.3				
2200				65.2	48.5	0.74	5.53	84.1	11.8	12.5	2200	65.2	48.5	0.74	5.53	84.1	11.8	12.5					
110	12.0	2.4	5.6	Operation not recommended							Operation not recommended												
	15.0	3.5	8.0	1850	59.8	43.5	0.73	5.76	79.4	10.4	14.9	1850	59.8	43.5	0.73	5.76	79.4	10.4	14.9				
				2200	61.0	46.8	0.77	6.13	81.9	10.0	16.1	2200	61.0	46.8	0.77	6.13	81.9	10.0	16.1				
	18.0	4.6	10.6	1850	60.4	43.9	0.73	5.66	79.8	10.7	13.8	1850	60.4	43.9	0.73	5.66	79.8	10.7	13.8				
2200				61.7	47.2	0.77	6.02	82.2	10.2	15.3	2200	61.7	47.2	0.77	6.02	82.2	10.2	15.3					
120	12.0	2.3	5.4	Operation not recommended							Operation not recommended												
	15.0	3.3	7.7	1850	55.6	41.7	0.75	6.52	77.9	8.5	18.0	1850	55.6	41.7	0.75	6.52	77.9	8.5	18.0				
				2200	56.6	45.3	0.80	6.69	79.4	8.5	19.5	2200	56.6	45.3	0.80	6.69	79.4	8.5	19.5				
	18.0	4.4	10.2	1850	56.1	41.7	0.74	6.31	77.6	8.9	16.7	1850	56.1	41.7	0.74	6.31	77.6	8.9	16.7				
2200				57.3	45.3	0.79	6.51	79.5	8.8	18.5	2200	57.3	45.3	0.79	6.51	79.5	8.8	18.5					

Wiring Schematics

Aurora Advanced with ECM and IntelliStart

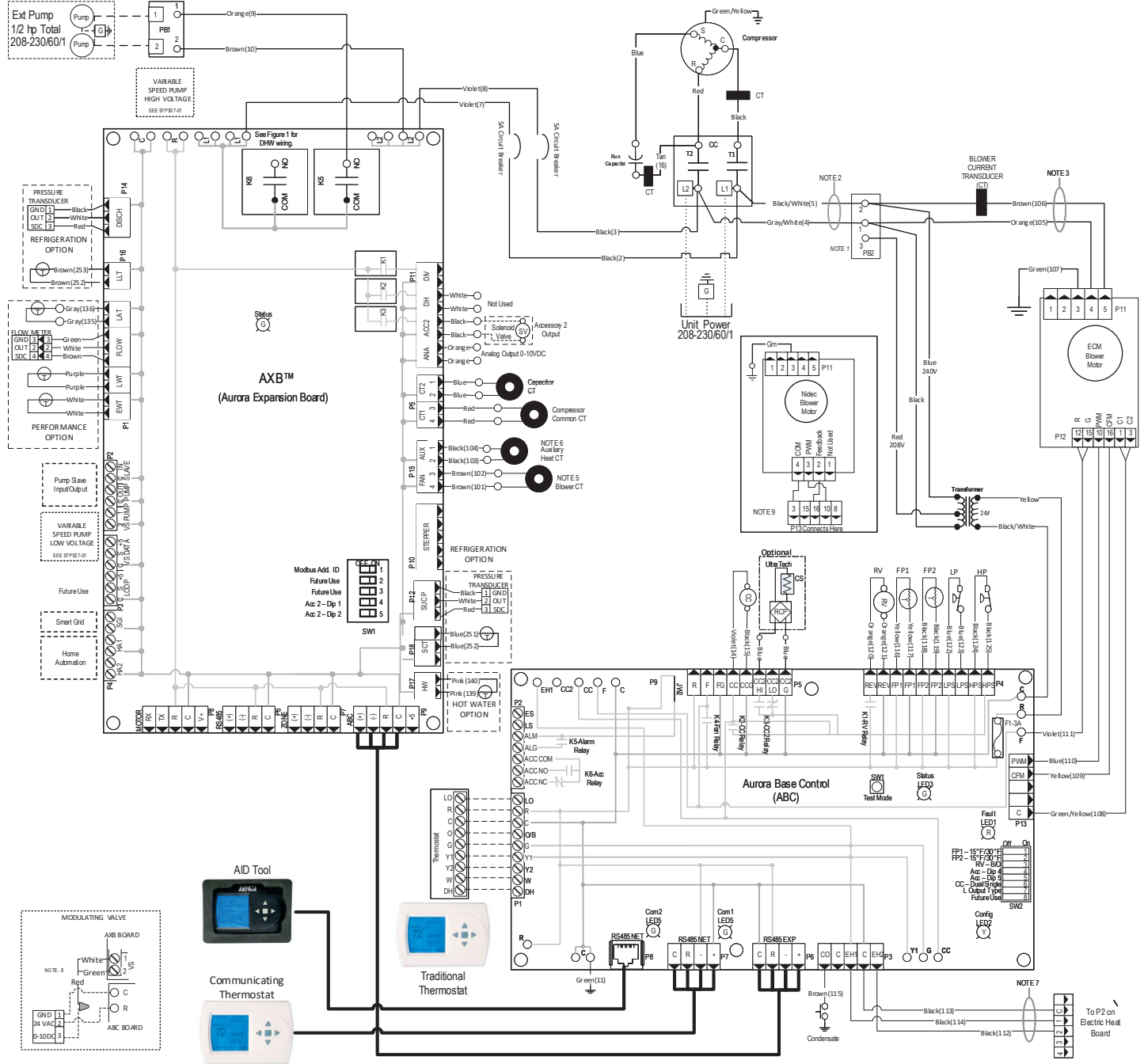

Wiring Schematics cont.

Aurora Advanced with ECM and IntelliStart cont.

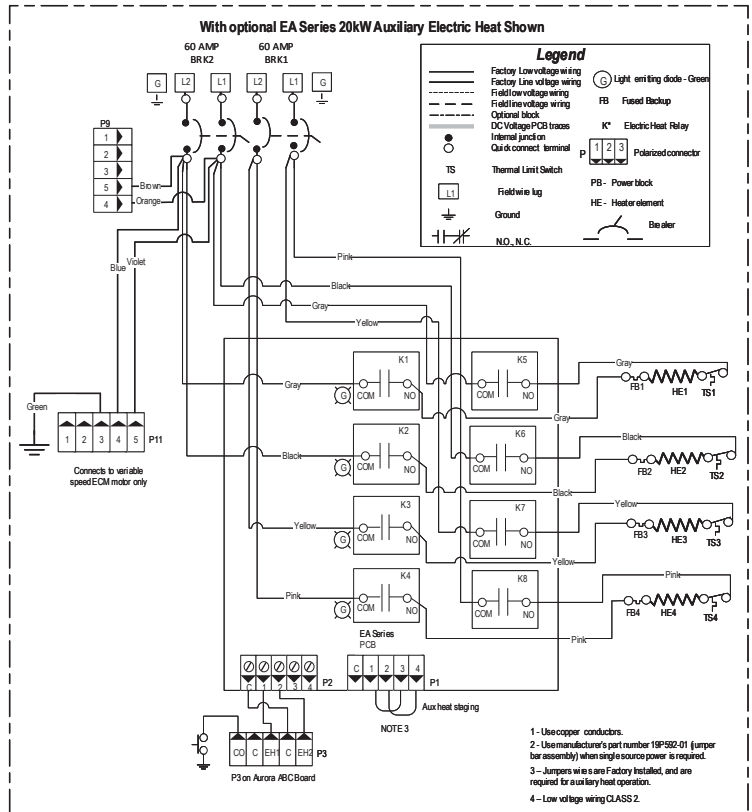

- Notes**
- 1 - Switch blue and red wires for 208V operation.
 - 2 - The bk/wh and gray/wh wires are removed when Aux. Heat is installed
 - 3 - When Auxiliary Heat is installed the harness will then be connected to the auxiliary heat unit. The auxiliary heat unit will then power the blower. Refer to EA/S/EA/MEAL Auxiliary Heat kit installation instructions.
 - 4 - Low voltage wiring CLASS 2.
 - 5 - Brown blower power wire routed through Current Transducer two times.
 - 6 - Field Connected. Refer to Installation Manual and Auxiliary Heat Instructions for Current Transducer installation.
 - 7 - Wires provided for Auxiliary Heat low voltage control. Wires are secured at blower.
 - 8 - Wiring harness supplied with valve.
 - 9 - On units with the NDEEC ECM motor the P13 harness connects to the jumper harness on the motor.

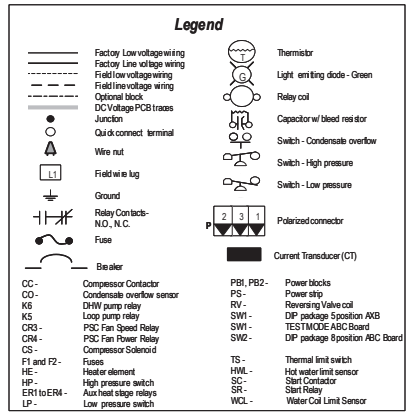

Wiring Schematics

Aurora Advanced with ECM and IntelliStart

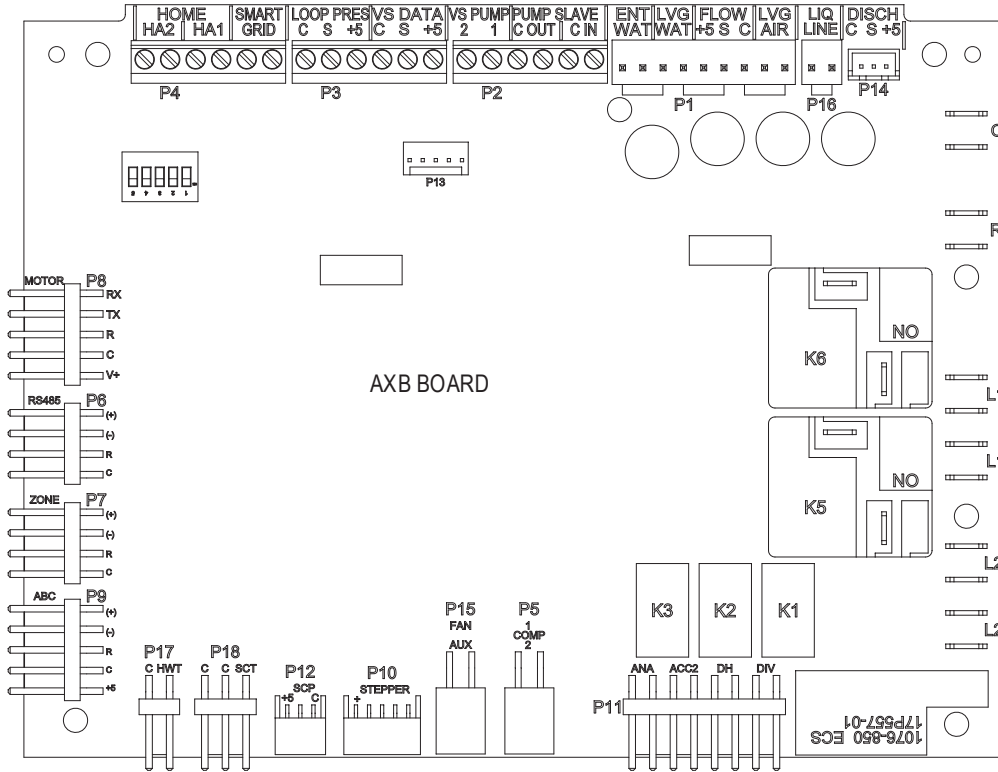

Aurora LED Flash Codes			
Slow Flash	1 second on and 1 second off		
Fast Flash	100 milliseconds on and 100 milliseconds off		
Flash Code	100 milliseconds on and 400 milliseconds off with a 2 second pause before repeating		
Fault LED (LED 1, Red)		Random Start Delay (Alternating Colors)	
Normal Mode	OFF	Status LED (LED1, Green)	Fast Flash
Input Fault Lockout	Flash Code 1	Configuration LED (LED 2, Yellow)	Fast Flash
High Pressure Lockout	Flash Code 2	Fault LED (LED 3, Red)	Fast Flash
Low Pressure Lockout	Flash Code 3	Configuration LED (LED 2, Yellow)	
Freeze Detection - FP2	Flash Code 4	No Software Override	OFF
Freeze Detection - FP1	Flash Code 5	DIP Switch Override	Slow Flash
Reserved	Flash Code 6	Status LED (LED 3, Green)	
Condensate Overflow Lockout	Flash Code 7	Normal Mode	ON
Over/Under Voltage Shutdown	Flash Code 8	Control is Non - Functional	OFF
Future Use	Flash Code 9	Test Mode	Slow Flash
Compressor Monitoring	Flash Code 10	Lockout Active	Fast Flash
Fault- FP1 Sensor Error	Flash Code 11	Dehumidification Mode	Flash Code 2
Future Use	Flash Code 12	Future Use	Flash Code 3
Non-Critical AXB Sensor Error	Flash Code 13	Future Use	Flash Code 4
Critical AXB Sensor Error	Flash Code 14	Load Shed	Flash Code 5
Alarm - Hot Water	Flash Code 15	ESD	Flash Code 6
Fault Variable Speed Pump	Flash Code 16	Future Use	Flash Code 7
Future Use	Flash Code 17	Fault LED (LED 1, Red) Cont.	
Non-Critical Communication Error	Flash Code 18	Alarm - Home Automation 1	Flash Code 23
Fault - Critical Communication Error	Flash Code 19	Alarm - Home Automation 2	Flash Code 24
Alarm - Low Loop Pressure	Flash Code 21	Fault - EEV Error	Flash Code 25
Fault - Communication ECM Fan Motor Error	Flash Code 22		

Wiring Schematics cont.

Aurora Advanced with ECM and IntelliStart cont.

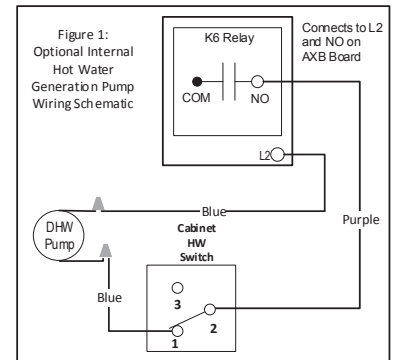
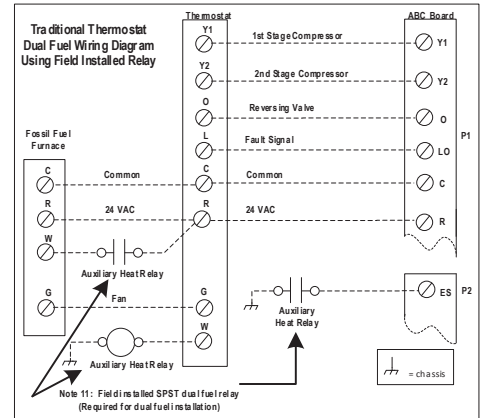
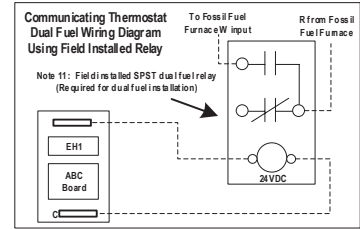
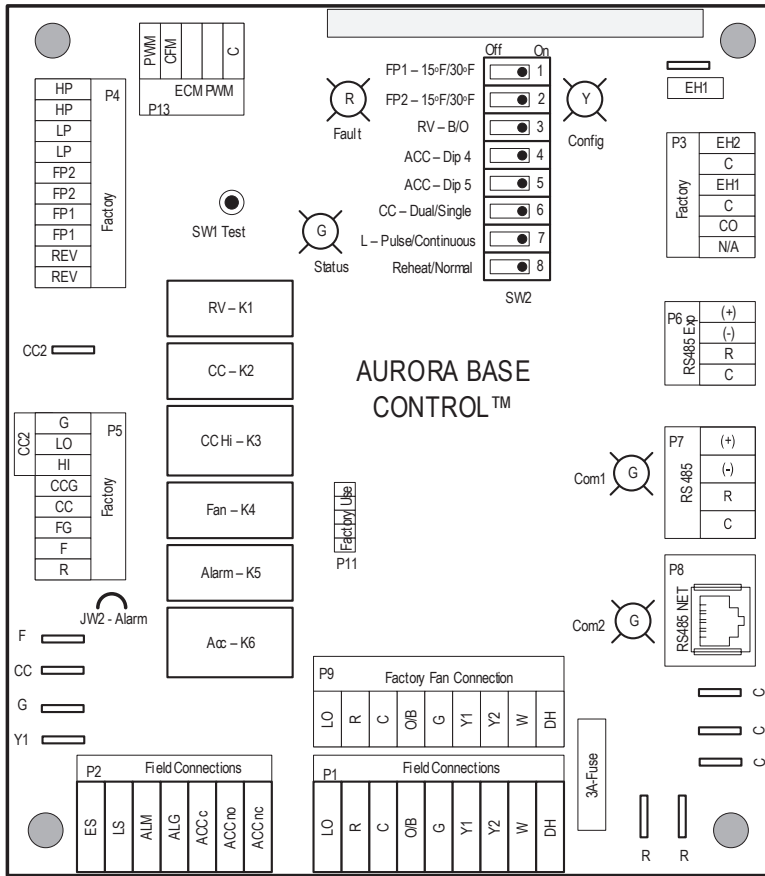

AXB Accessory 2 DIP Settings		
SW1-4	SW1-5	DESCRIPTION
ON	ON	Cycles with Blower
OFF	ON	Cycles with CC first stage compressor or compressor spd 1-12
ON	OFF	Cycles with CC2 second stage of compressor or comp spd 7-12
OFF	OFF	Cycles with DH from ABC board

ABC SW2 Accessory Relay		
DESCRIPTION	SW2-4	SW2-5
Cycle with Blower	ON	ON
Cycle with Compressor	OFF	OFF
Water Valve Slow Opening	ON	OFF
Cycle with Comm. T-stat Hum Cmd	OFF	ON

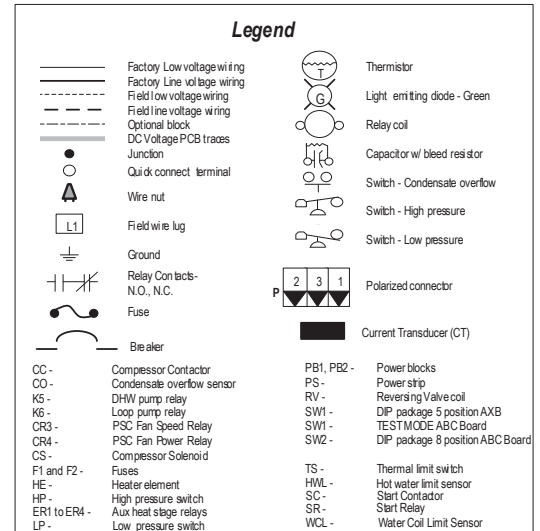
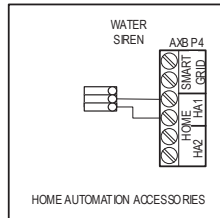

Wiring Schematics cont.

Aurora Advanced with 5-Speed ECM

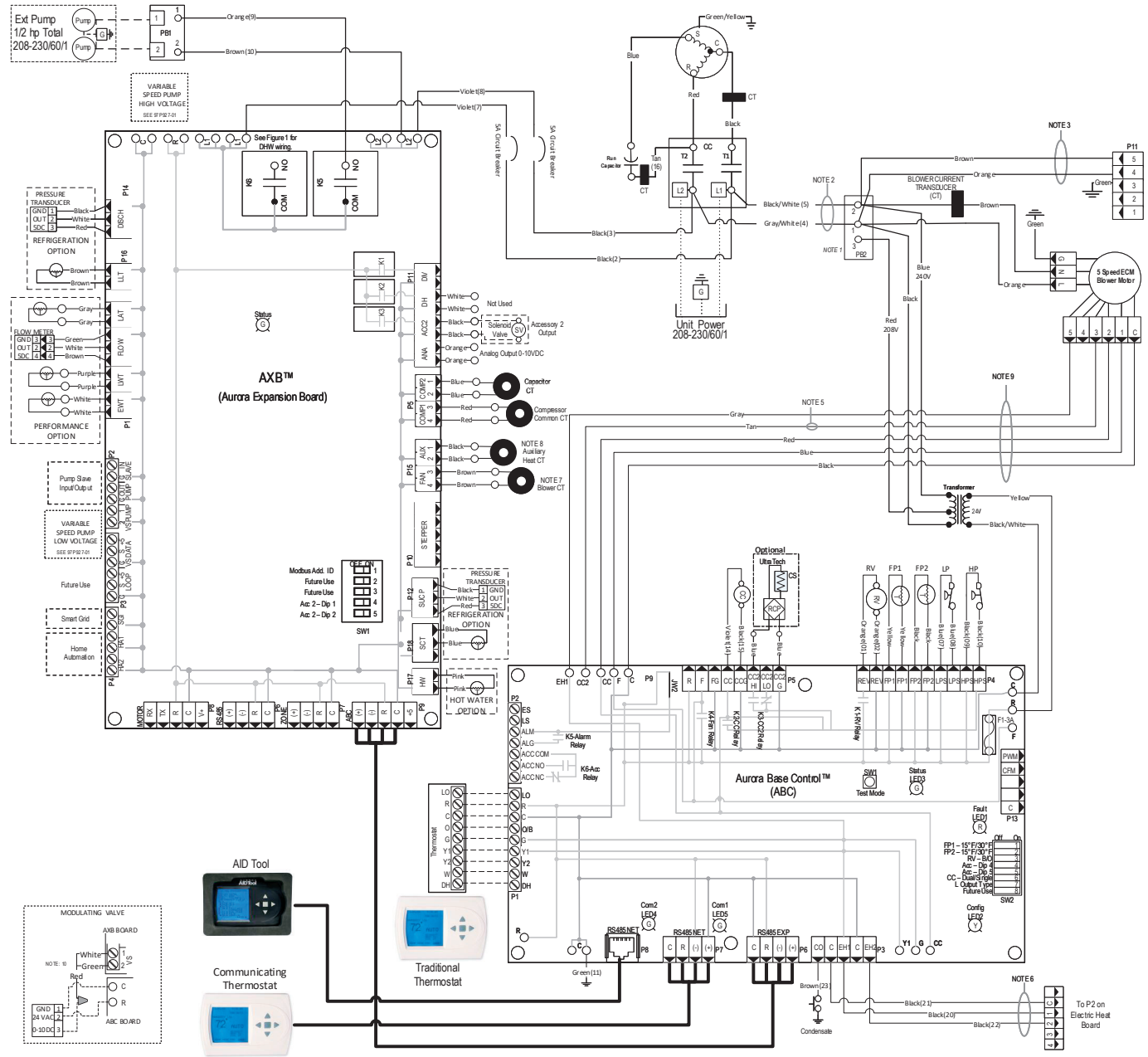

Wiring Schematics cont.

Aurora Advanced with 5-Speed ECM cont.

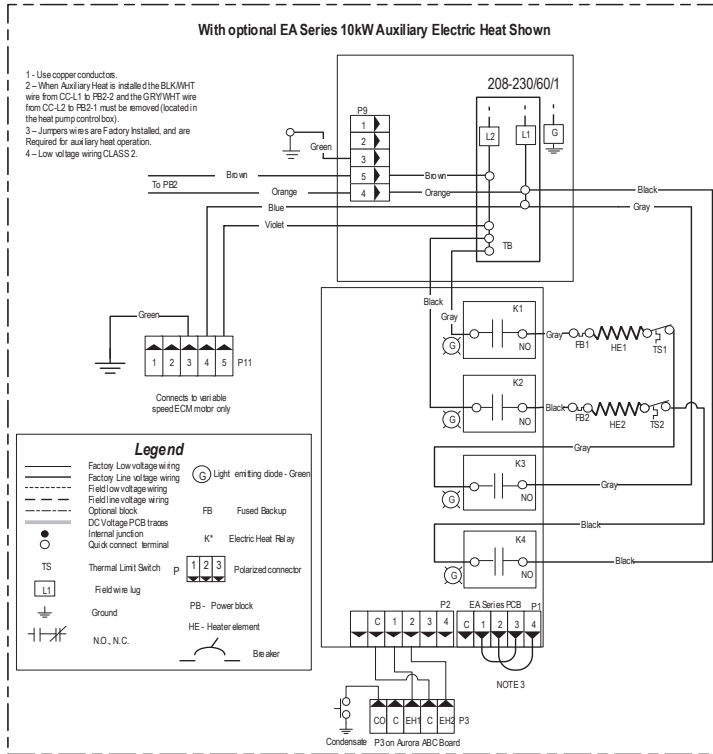

- Notes
- 1 - Switch blue and red wires for 208V operation.
 - 2 - The blk/wht and gray/wht wires are removed when Aux Heat is installed
 - 3 - When Auxiliary Heat is field installed the harness will be connected to the auxiliary heat unit. The auxiliary heat unit will then power the blower. Refer to EA/SEA/MEAL Auxiliary Heat kit installation instructions. Wires are secured at blower
 - 4 - Low voltage wiring CLASS 2.
 - 5 - Y2 input wire Tan not connected on Single Speed units. Wire is secured at blower.
 - 6 - Wires provided for Auxiliary Heat low voltage control. Wires are secured at blower.
 - 7 - Brown blower power wire routed through Current Transducer two times.
 - 8 - Field Connected: Refer to Installation Manual and Auxiliary Heat Instructions for Current Transducer installation.
 - 9 - Refer to units 5 SPEED ECM MOTOR LOW VOLTAGE CONNECTION table for factory settings.
 - 10 - Wiring harness supplied with valve.
 - 11 - Field installed SPST relay required for dual fuel installation.

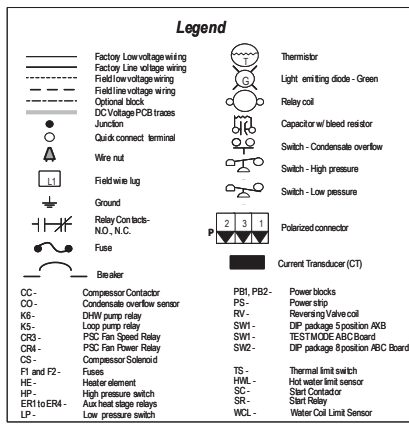

Wiring Schematics cont.

Aurora Advanced with 5-Speed ECM

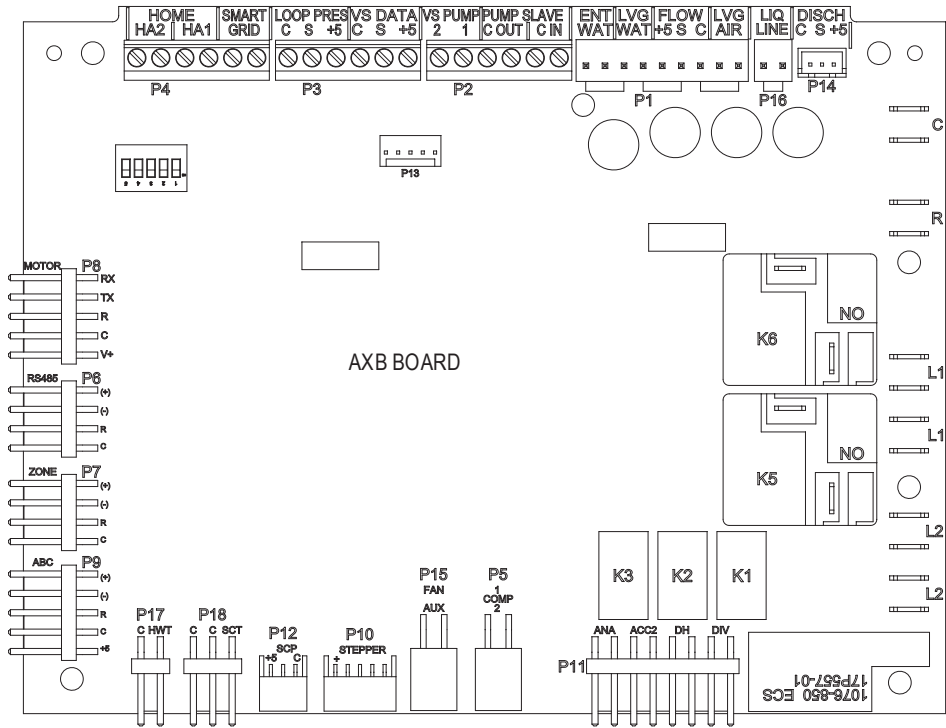

Aurora LED Flash Codes			
Slow Flash	1 second on and 1 second off		
Fast Flash	100 milliseconds on and 100 milliseconds off		
Flash Code	100 milliseconds on and 400 milliseconds off with a 2 second pause before repeating		
Fault LED (LED 1, Red)		Random Start Delay (Alternating Colors)	
Normal Mode	OFF	Status LED (LED 1, Green)	Fast Flash
Input Fault Lockout	Flash Code 1	Configuration LED (LED 2, Yellow)	Fast Flash
High Pressure Lockout	Flash Code 2	Fault LED (LED 3, Red)	Fast Flash
Low Pressure Lockout	Flash Code 3	Configuration LED (LED 2, Yellow)	
Freeze Detection - FP2	Flash Code 4	No Software Override	OFF
Freeze Detection - FP1	Flash Code 5	DIP Switch Override	Slow Flash
Reserved	Flash Code 6	Status LED (LED 3, Green)	
Condensate Overflow Lockout	Flash Code 7	Normal Mode	ON
Over/Under Voltage Shutdown	Flash Code 8	Control is Non - Functional	OFF
Future Use	Flash Code 9	Test Mode	Slow Flash
Compressor Monitoring	Flash Code 10	Lockout Active	Fast Flash
Fault- FP1 Sensor Error	Flash Code 11	Dehumidification Mode	Flash Code 2
Future Use	Flash Code 12	Future Use	Flash Code 3
Non-Critical AXB Sensor Error	Flash Code 13	Future Use	Flash Code 4
Critical AXB Sensor Error	Flash Code 14	Load Shed	Flash Code 5
Alarm - Hot Water	Flash Code 15	ESD	Flash Code 6
Fault Variable Speed Pump	Flash Code 16	Future Use	Flash Code 7
Future Use	Flash Code 17	Fault LED (LED 1, Red) Cont.	
Non-Critical Communication Error	Flash Code 18	Alarm - Home Automation 1	Flash Code 23
Fault - Critical Communication Error	Flash Code 19	Alarm - Home Automation 2	Flash Code 24
Alarm - Low Loop Pressure	Flash Code 21	Fault - EEV Error	Flash Code 25
Fault - Communication ECM Fan Motor Error	Flash Code 22		

5 SPEED ECM MOTOR LOW VOLTAGE CONNECTIONS SINGLE SPEED					
Model	TAP-1	TAP-2	TAP-3	TAP-4	TAP-5
22		BLUE		RED	GRAY
30	BLUE		RED	GRAY	
36	BLUE			RED	GRAY
42	BLUE	RED		GRAY	
48	BLUE		RED	GRAY	
60	BLUE			RED	GRAY
70	BLUE			RED	GRAY
5 SPEED ECM MOTOR LOW VOLTAGE CONNECTIONS DUAL CAPACITY					
Model	TAP-1	TAP-2	TAP-3	TAP-4	TAP-5
26	BLUE	RED		TAN	GRAY
38	BLUE		RED	TAN	GRAY
49	BLUE	RED	TAN		GRAY
64	BLUE	RED		TAN	GRAY
72	BLUE	RED		TAN	GRAY

Wiring Schematics cont.

Aurora Advanced with 5-Speed ECM cont.

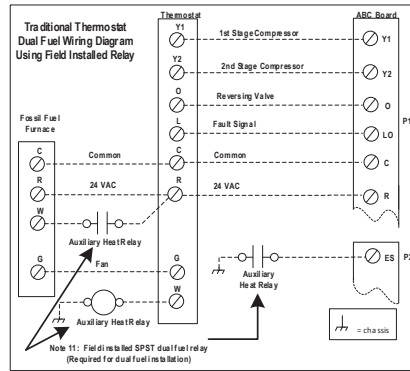
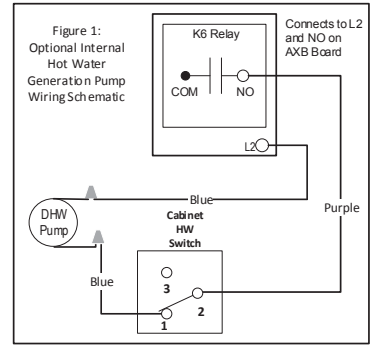
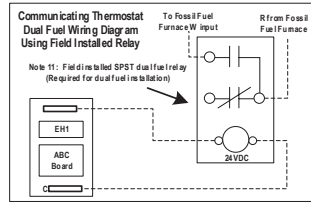
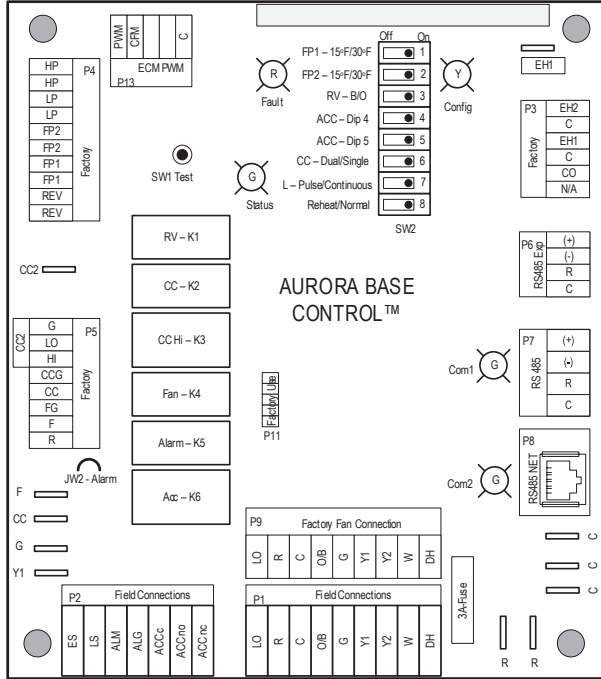

AXB Accessory 2 DIP Settings		
SW1-4	SW1-5	DESCRIPTION
ON	ON	Cycles with Blower
OFF	ON	Cycles with CC first stage compressor or compressor spd 1-12
ON	OFF	Cycles with CC2 second stage of compressor or comp spd 7-12
OFF	OFF	Cycles with DH from ABC board

ABC SW2 Accessory Relay		
DESCRIPTION	SW2-4	SW2-5
Cycle with Blower	ON	ON
Cycle with Compressor	OFF	OFF
Water Valve Slow Opening	ON	OFF
Cycle with Comm. T-stat Hum Cmd	OFF	ON

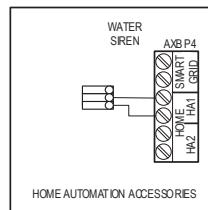

Wiring Schematics cont.

Aurora Base with PSC

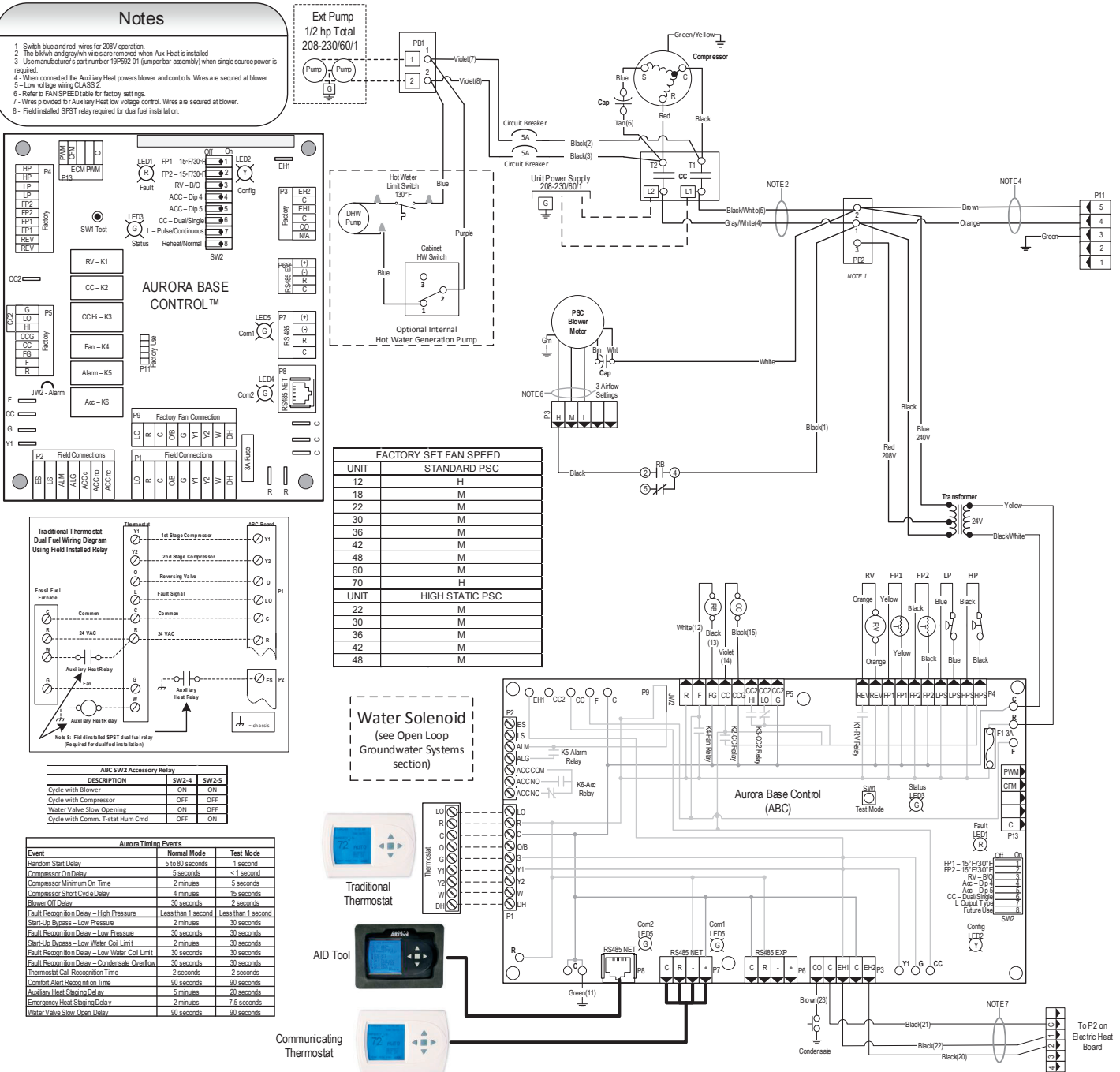

Wiring Schematics cont.

Aurora Base with PSC cont.

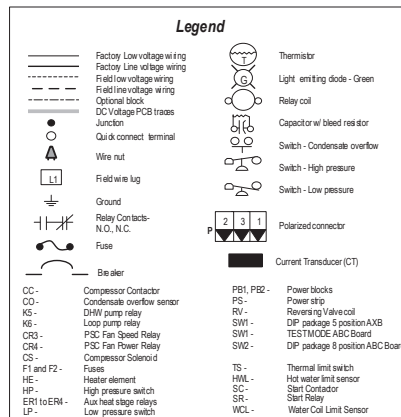
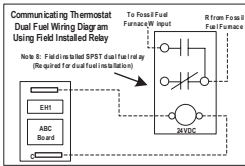
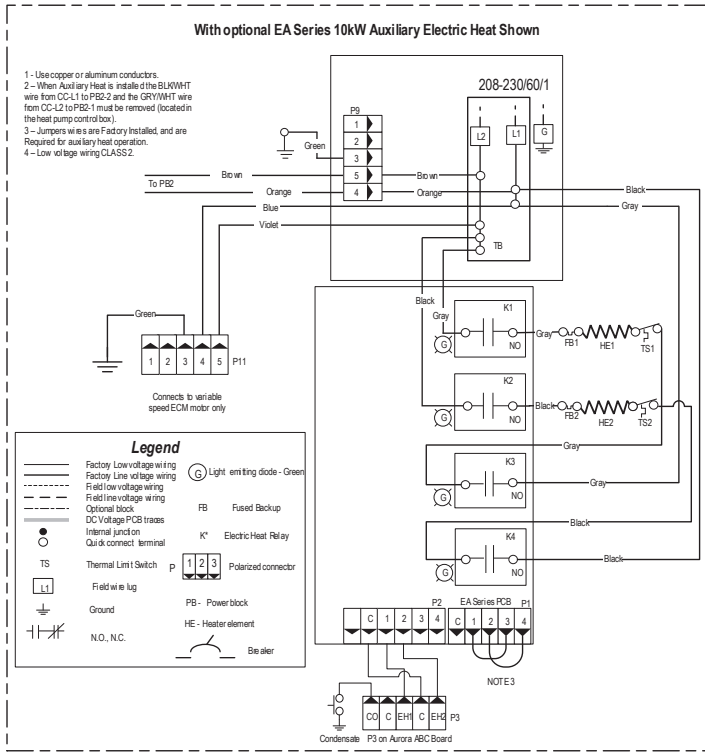

Aurora LED Flash Codes			
Slow Flash	1 second on and 1 second off		
Fast Flash	100 milliseconds on and 100 milliseconds off		
Flash Code	100 milliseconds on and 500 milliseconds off with a 2 second pause before repeating		
Random Start Delay (Alternating Colors)	Configuration LED (LED2, Yellow)		
Status LED (LED1, Green)	Fast Flash	No Software Update	
Configuration LED (LED2, Yellow)	Fast Flash	DIP Switch Overide	
Fault LED (LED3, Red)	Fast Flash	Slow Flash	
Fault LED (LED1, Red)		Status LED (LED3, Green)	
Normal Mode	OFF	Normal Mode	ON
Input Fault Lockout	Flash Code 1	Control is Non-Functional	OFF
High Pressure Lockout	Flash Code 2	Test Mode	Slow Flash
Low Pressure Lockout	Flash Code 3	Lockout Active	Fast Flash
Future Use	Flash Code 4	Dehumidification Mode	Flash Code 2
Future Use	Flash Code 5	Future Use	Flash Code 3
Reserved	Flash Code 6	Future Use	Flash Code 4
Condensate Overflow Lockout	Flash Code 7	Lead Shed	Flash Code 5
Over/Under Voltage Shutdown	Flash Code 8	ESD	Flash Code 6
Future Use	Flash Code 9	Future Use	Flash Code 7
Future Use	Flash Code 10		
FP1 Sensor Error	Flash Code 11		

Wiring Schematics cont.

Aurora Base with ECM, IntelliStart and UPC

- Notes**
- Switch blade and red wires for 209V operation.
 - The bk/wh and gray/wh wires are removed when Aux Heat is installed.
 - Use manufacturer's part number 19P592-01 (Jumper bar assembly) when a single source power is required.
 - When installed the Auxiliary Heat powers blower and controls.
 - Low voltage wiring CLASS 2.
 - Wires provided for Auxiliary Heat low voltage control. Wires are secured at blower.
 - Field installed SPST relay required for dual fuel installation.

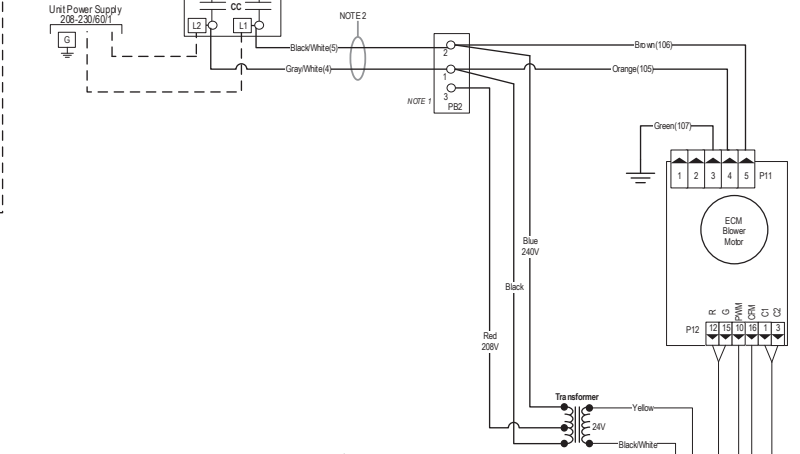
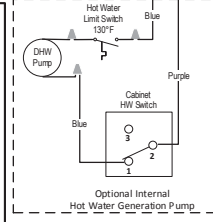
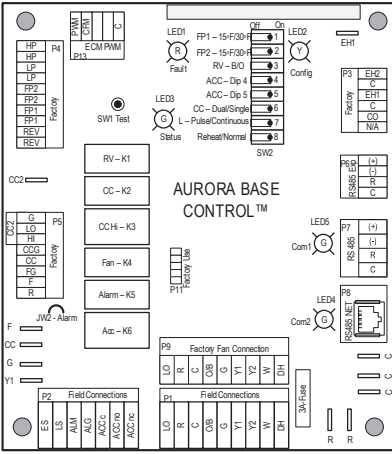
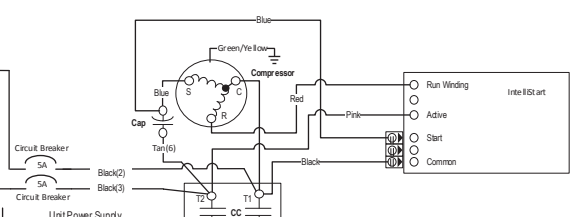
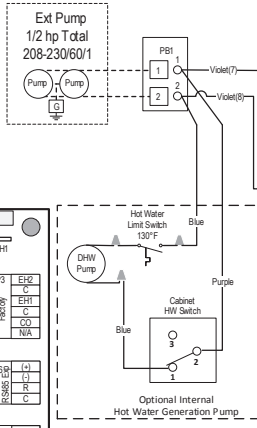

Event	Normal Mode	Test Mode
Random Start Delay	5 to 80 seconds	1 second
Compressor On Delay	5 seconds	< 1 second
Compressor Minimum On Time	2 minutes	5 seconds
Compressor Short Cycle Delay	4 minutes	15 seconds
Blower Off Delay	30 seconds	2 seconds
Fault Recognition Delay - High Pressure	FP2 - 15/F30/F	Less than 1 second
Start-Up Bypass - Low Pressure	RV - B/O	30 seconds
Fault Recognition Delay - Low Pressure	ACC - Dp 4	30 seconds
Start-Up Bypass - Low Water Coil Limit	CC - Dual/Single	30 seconds
Fault Recognition Delay - Low Water Coil Limit	L - Pulse/Continuous	30 seconds
Fault Recognition Delay - Condensate Overflow	SW2	30 seconds
Thermostat Call Recognition Time	2 seconds	2 seconds
Combust Alert Recognition Time	90 seconds	30 seconds
Auxiliary Heat Start Delay	4 minutes	20 seconds
Emergency Heat Staging Delay	2 minutes	7.5 seconds
Water Valve Slow Open Delay	90 seconds	90 seconds

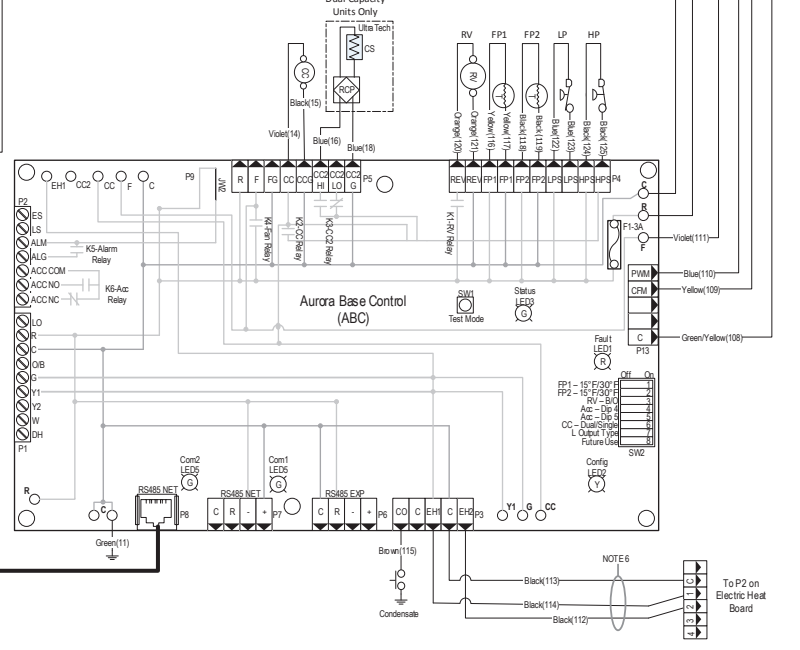
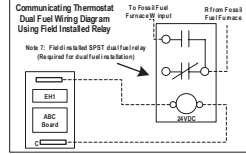

Water Solenoid
(see Open Loop Groundwater Systems section)

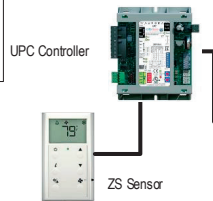
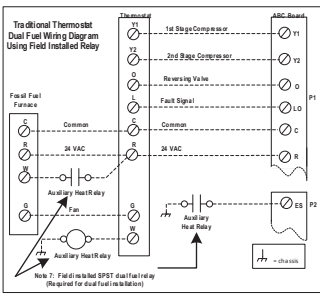

Wiring Schematics cont.

Aurora Base with ECM, IntelliStart and UPC cont.

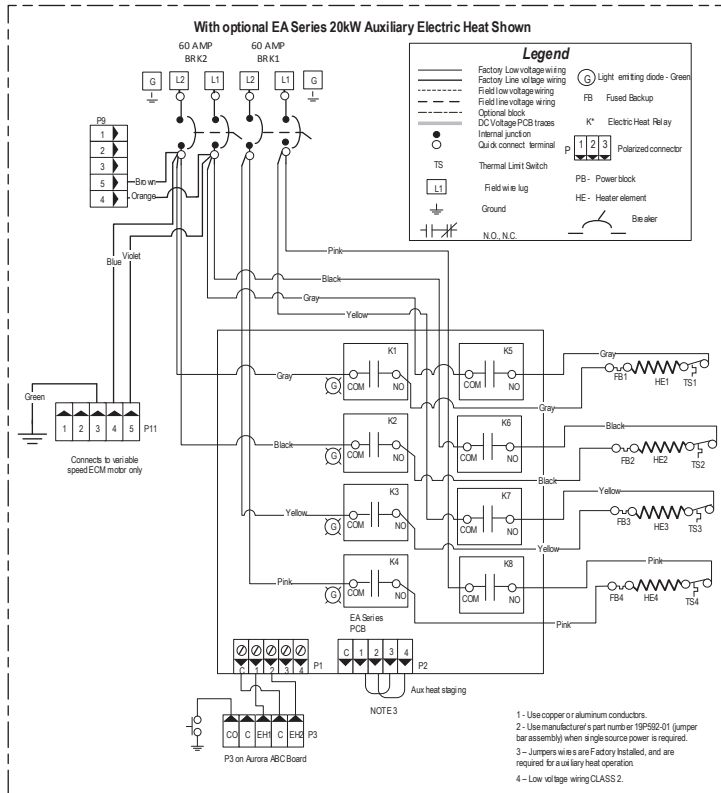

ABC SW2 Accessory Relay		
DESCRIPTION	SW2-4	SW2-5
Cycle with Blower	ON	ON
Cycle with Compressor	OFF	OFF
Water Valve Slow Opening	ON	OFF
Cycle with Comm. T-stat Hum Cmd	OFF	ON

Aurora LED Flash Codes			
Slow Flash	1 second on and 1 second off		
Fast Flash	100 milliseconds on and 100 milliseconds off		
Flash Code	100 milliseconds on and 400 milliseconds off with a 2 second pause before repeating		
Random Start Delay (Alternating Colors)		Configuration LED (LED2, Yellow)	
Status LED (LED1, Green)	Fast Flash	No Software Override	OFF
Configuration LED (LED2, Yellow)	Fast Flash	DP-Switch Disabled	Slow Flash
Fault LED (LED3, Red)	Fast Flash		
Fault LED (LED1, Red)		Status LED (LED3, Green)	
Normal Mode	OFF	Normal Mode	ON
Input Fault Lockout	Flash Code 1	Control is Non-Functional	OFF
High Pressure Lockout	Flash Code 2	Test Mode	Slow Flash
Low Pressure Lockout	Flash Code 3	Lockout Active	Fast Flash
Future Use	Flash Code 4	Defrost/Defination Mode	Flash Code 2
Freeze Detection - FP1	Flash Code 5	Future Use	Flash Code 3
Reserved	Flash Code 6	Future Use	Flash Code 4
Condensate Overflow Lockout	Flash Code 7	Load Shed	Flash Code 5
Over/Under Voltage Shutdown	Flash Code 8	ESD	Flash Code 6
Future Use	Flash Code 9	Future Use	Flash Code 7
Future Use	Flash Code 10		
FP1 Sensor Error	Flash Code 11		

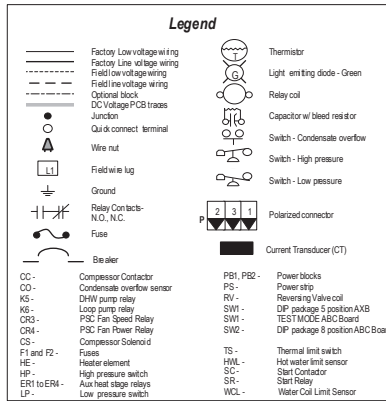

Wiring Schematics cont.

Variable Speed Pump (UPMXL 25-124)

Variable Speed Flow Center With 1 – UPMXL 25-124 Pump

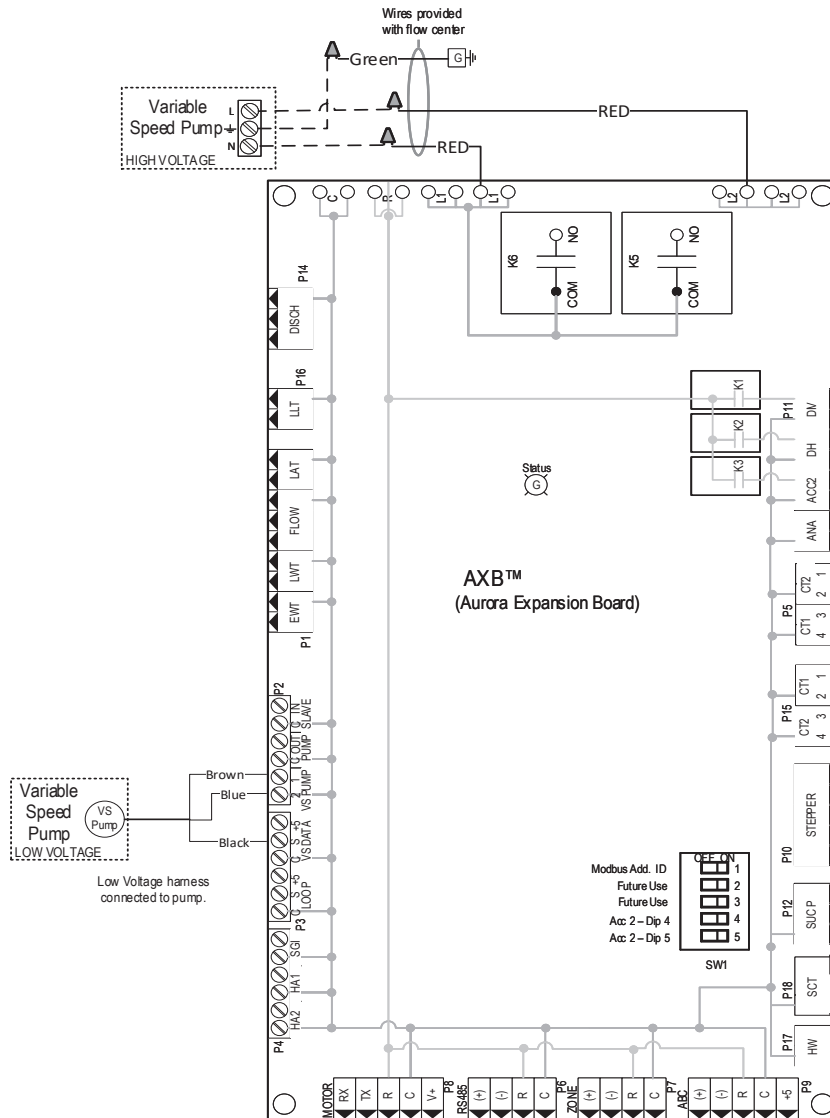

Wiring Schematics cont.

Variable Speed Pump (UPMXL 25-124)

Variable Speed Flow Center With 2 – UPMXL 25-124 Pumps

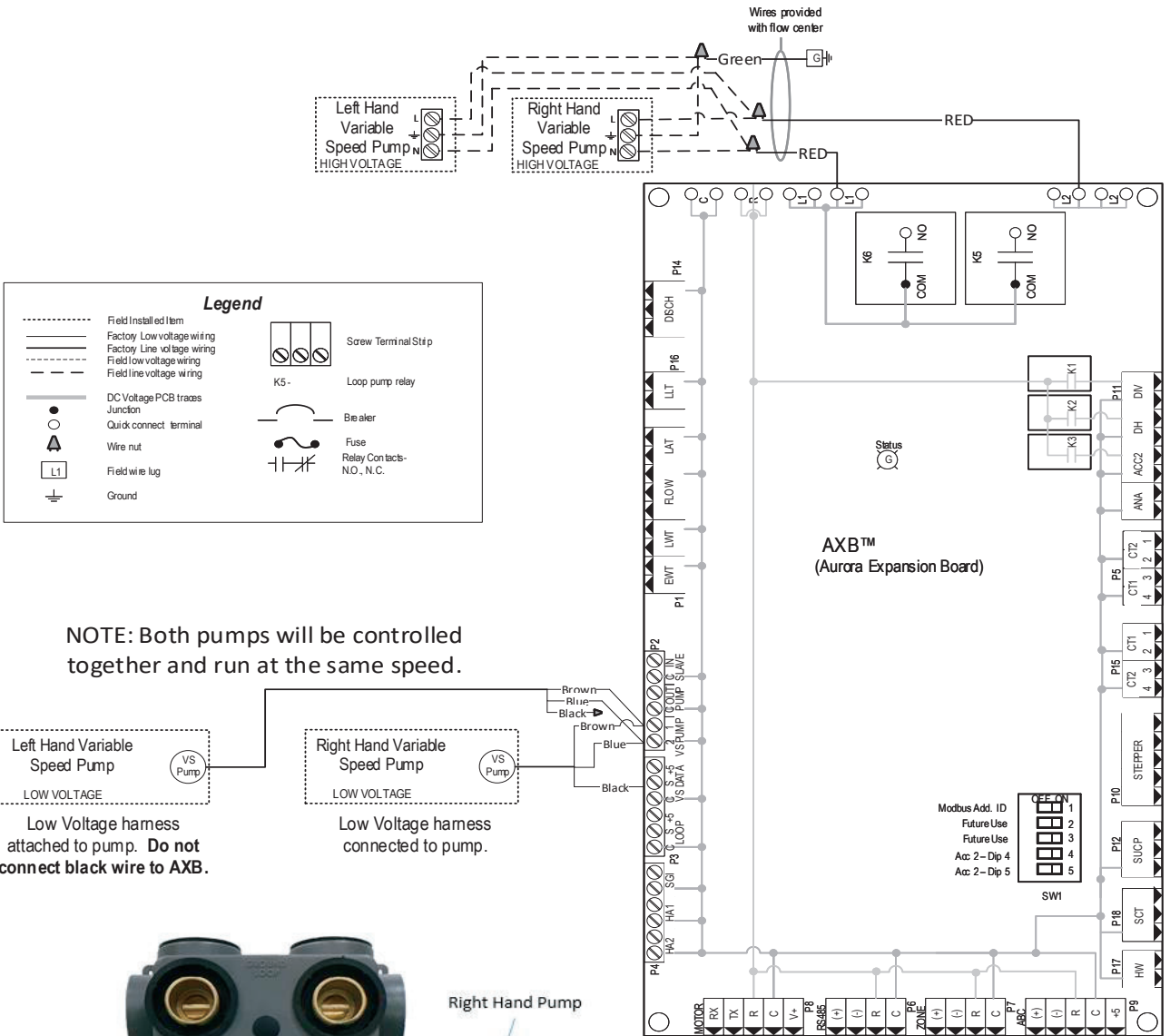

Engineering Guide Specifications

General

Furnish and install GeoStar Water Source Heat Pumps, as indicated on the plans. Equipment shall be completely assembled, piped and internally wired. Capacities and characteristics as listed in the schedule and the specifications that follow. The reverse cycle heating/cooling units shall be either suspended type with horizontal air inlet and discharge or floor mounted type with horizontal air inlet and vertical upflow, downflow, or rear air discharge. Units shall be AHRI/ISO 13256-1 certified and listed by a nationally recognized safety-testing laboratory or agency, such as ETL Testing Laboratory. Each unit shall be computer run-tested at the factory with conditioned water and operation verified to catalog data. Each unit shall be mounted on a pallet and shipped in a corrugated box or stretch-wrapped. The units shall be designed to operate with entering liquid temperature between 20°F and 120°F [-6.7°C and 48.9°C].

Casing and Cabinet

The cabinet shall be fabricated from heavy-gauge galvanized steel and finished with corrosion-resistant powder coating. This corrosion protection system shall meet the stringent 1000 hour salt spray test per ASTM B117. The interior shall be insulated with 1/2-inch thick, multi-density, cleanable aluminum foil coated glass fiber with edges sealed or tucked under flanges to prevent the introduction of glass fibers into the discharge air. Standard cabinet panel insulation must meet NFPA 90A requirements, air erosion and mold growth limits of UL-181, stringent fungal resistance test per ASTM-C1071 and ASTM G21, and shall meet zero level bacteria growth per ASTM G22. Unit insulation must meet these stringent requirements or unit(s) will not be accepted.

One (horizontal) to two (vertical) blower and three compressor compartment access panels shall be 'lift-out' removable with supply and return ductwork in place. The front access panel shall be lift-out to provide easy access to the electrical/compressor section. The control box shall be hinged and removable to allow easy access to the compressor. The internal component layout shall provide for service access from the front side for restricted installations.

A duct collar shall be provided on the supply air opening. Standard size 2 in. [5.1 cm] MERV 11 pleated filters shall be provided with each unit. Vertical units shall have a return air filter rack/duct collar; the horizontal units shall have a filter bracket each field convertible from 2 in. [5.1 cm] to 1 in. [2.5 cm]. The upflow vertical (022-072) units shall have a removable insulated divider panel between the air handling section and the compressor section to minimize the transmission of compressor noise and to permit operational service testing without air bypass. Vertical units shall be supplied with left or right horizontal air inlet and top, bottom (022-072), or rear vertical (042-072) air discharge. Horizontal units shall be supplied with left or right air inlet and side or end air discharge.

The compressor shall be double isolation mounted using selected durometer grommets to provide vibration free compressor mounting.

The drain pan shall be of plastic construction to inhibit corrosion and bacterial growth. Drain outlet shall be located on pan as to allow complete and unobstructed drainage of condensate. The unit as standard will be supplied with solid-state electronic condensate overflow protection. Mechanical float switches WILL NOT be accepted. Vertical units shall be furnished with a PVC slip condensate drain connection and an internal factory installed condensate trap.

Refrigerant Circuit

All units shall contain a sealed refrigerant circuit including a hermetic motor-compressor, discharge line muffler (022-072), bidirectional thermostatic expansion valve, finned tube air-to-refrigerant heat exchanger, reversing valve, coaxial tube water-to-refrigerant heat exchanger, optional hot water generator coil (018-072), and service ports.

Compressors shall be high-efficiency single speed rotary or scroll, or dual capacity scroll type designed for heat pump duty and mounted on vibration isolators. Compressor motors shall be single-phase PSC with overload protection. The finned tube air-to-refrigerant heat exchanger will be aluminum tube/fin or copper tube/aluminum fin and shall be sized for low-face velocity and constructed of lanced aluminum fins bonded to performance enhanced tubes in a staggered pattern not less than three rows deep for superior performance. The aluminum tube and fin air-to-refrigerant heat exchanger has as optional to be electro-coated with AlumiSeal. Models 022-072 shall include discharge mufflers to help quiet compressor discharge gas pulsations. Refrigerant to air heat exchangers shall utilize enhanced tube construction rated to withstand 600 psig (4135 kPa) refrigerant working pressure.

The coaxial water-to-refrigerant heat exchanger shall be designed for low water pressure drop and constructed of a convoluted copper (cupronickel option) inner tube and a steel outer tube. Refrigerant to water heat exchangers shall be of copper inner water tube and steel refrigerant outer tube design, rated to withstand 600 psig (4135 kPa) working refrigerant pressure and 450 psig (3101 kPa) working water pressure. The thermostatic expansion valve shall provide proper superheat over the entire liquid temperature range with minimal "hunting." The valve shall operate bidirectionally without the use of check valves.

All units shall have the source coaxial tube refrigerant-to-water heat exchanger and the optional hot water generator coil shall be coated with ThermaShield. Refrigerant suction lines shall be insulated to prevent condensation at low liquid temperatures.

Engineering Guide Specifications cont.

Blower Motor and Assembly

The blower shall be a direct drive centrifugal type with a dynamically balanced wheel. The housing and wheel shall be designed for quiet low outlet velocity operation. The blower housing shall be removable from the unit without disconnecting the supply air ductwork for servicing of the blower motor. The blower motor shall be a 4-speed PSC (012 only), 5-speed ECM, or variable-speed ECM type. The variable speed ECM blower motor shall be soft starting, shall maintain constant cfm over its operating static range, and shall provide 12 cfm settings. An optional constant torque 5-speed ECM is available on model sizes 022-072. The blower motor shall be isolated from the housing by rubber grommets. The motor shall be permanently lubricated and have thermostatic overload protection. Variable speed ECM and 5-speed ECM motors shall be long-life ball bearing type.

Electrical

A control box shall be located within the unit compressor compartment and shall contain a 75VA transformer, 24 volt activated, 2 pole compressor contactor, circuit breakers for protecting loop pumps, terminal block for thermostat wiring, and solid-state controller for complete unit operation. Electromechanical operation WILL NOT be accepted. Units shall be name-plated for use with time delay fuses or HACR circuit breakers. Unit controls shall be 24 volt and provide heating or cooling as required by the remote thermostat/sensor. An Aurora, a microprocessor-based controller, interfaces with a multi-stage electronic thermostat to monitor and control unit operation shall be provided. The control shall provide operational sequencing, blower speed control, blower failure, high and low pressure switch monitoring, freeze detection, hot water limit thermistor sensing, condensate overflow sensing, auxiliary heat staging, lockout mode control, hot water and loop pump control, LED status and fault indicators, fault memory, field selectable options, and accessory output. The Lockout signal output shall have a pulsed option so that DDC systems can read specific lockout conditions from the control.

The optional Aurora Advanced Control shall also feature an Energy Monitoring Package that will provide real time total power consumption, compressor monitoring, On Peak input signal for utility controlled demand programs, intelligent hot water generation with user adjustable temperature limit, loop pump linking for multiple units driving a common flow center and up to two optional home automation inputs to drive dedicated alarms for sump pump, security system, and smoke/CO₂ or dirty air filter sensors. Optional Refrigerant and Performance Monitoring kits to provide real time data including refrigerant superheat and subcooling, as well as heat of extraction/rejection capacity data. The capability for communicating to advanced IntelliZone2 zoning packages with up to 6 zones (Variable Speed), 4 zones (Dual Capacity), or 2 zones (Single Speed) shall also be provided with complete fault and information display on the zoning MasterStat.

A detachable terminal block with screw terminals will be provided for field control wiring. All units shall have knockouts for entrance of low and line voltage wiring. The blower motor and control box shall be harness plug wired for easy removal.

An optional Aurora Interface Diagnostic (AID) Tool shall communicate with the Aurora control allowing quick and easy access to setup, monitoring, and troubleshooting of any Aurora

control. The device shall include the features of ECM airflow setup, fault description and history, manual operation capability, sensor readings, timings, and other diagnostic tools.

Optional IntelliStart® (compressor Soft Starter) shall be factory installed for use in applications that require low starting amps, reduced compressor start-up noise, off-grid, and improved start-up behavior. IntelliStart shall reduce normal starting current by up to 60%.

Piping

Supply and return water connections shall be 1 in. [25.4 mm] FPT brass swivel fittings, which provide a union and eliminate the need for pipe wrenches and sealants when making field connections. The optional hot water generator shall have sweat type connections. All water piping shall be insulated to prevent condensation at low liquid temperatures, on the vertical units, the condensate connection shall be a 3/4 in. [19.1 mm] PVC socket with internally-trapped hose that can be routed to front or side locations.

Hanger Kit

(field-installed horizontal units only)

The hanger kit shall consist of galvanized steel brackets, bolts, lock washers, and isolators and shall be designed to fasten to the unit bottom panel for suspension from 3/8-inch threaded rods. Unit sizes 012-030 shall include four brackets. Unit sizes 036-072 shall include six brackets.

Options and Accessories

Cupronickel Heat Exchanger

An optional cupronickel water-to-refrigerant heat exchanger shall be provided.

Hot Water Generator

An optional ThermaShield coated heat reclaiming hot water generator coil of vented double-wall copper construction suitable for potable water shall be provided. The coil and hot water circulating pump shall be factory mounted inside the unit with integral electronic high limit temperature monitoring and external on/off switch.

5-Speed ECM Blower Motor

An optional constant torque 5-speed ECM blower motor is available on model sizes 022-072.

Engineering Guide Specifications cont.

Thermostat (field-installed)

A multi-stage auto-changeover electronic digital thermostat shall be provided. The thermostat shall offer three heating and two cooling stages with precise temperature control. An OFF-HEAT-AUTO-COOL-EMERG system switch, OFF-AUTO blower switch, and indicating LEDs shall be provided. The thermostat shall display in °F or °C. The thermostat shall be either a communicating type or a traditional 24 VAC type.

Communicating Thermostat (field-installed)

A communicating auto-changeover electronic digital thermostat shall be provided. The thermostat shall offer variable speed heating and cooling staging with precise temperature control. An OFF-HEAT-AUTO-COOL-EMERG system switch, OFF-AUTO blower switch, and indicating display shall be provided. The thermostat shall display in °F or °C. The thermostat shall provide real time energy consumption data of the unit.

Communicating Color Touchscreen Thermostat (field-installed)

A color touchscreen communicating auto-changeover electronic digital thermostat shall be provided. The thermostat shall offer variable speed heating and cooling staging with precise temperature control. An OFF-HEAT-AUTO-COOL-EMERG system switch, OFF-AUTO blower switch, and indicating display shall be provided. The thermostat shall display in °F or °C. The thermostat shall provide real time and historical energy consumption data of the unit.

Electronic Air Cleaner (field-installed)

A 1 in. [25 mm] electronic air cleaner, cleanable 97% efficiency at 0.3 microns and larger, shall be provided in lieu of the standard throwaway filter. The initial pressure drop across the filter shall not exceed 0.2 in. w.g. at 300 fpm force velocity.

Electrostatic Air Cleaner (field-installed)

A 1 in. [25 mm] electrostatic air cleaner, cleanable 90% efficiency, shall be provided in lieu of the standard throwaway filter. The initial pressure drop across the filter shall not exceed 0.15 in. w.g. at 300 fpm force velocity.

External Sump Alarm Sensors for Aurora Controls

The sensor can be added to any Aurora Advanced Control System (including both ABC and AXB) to monitor a sump pump. The sensor can be connected to the Aurora Home Automation inputs (HA-1 or HA-2) of the AXB board. These will each display an E23 and E24 code respectively when the alarm is active and when Symphony/AWL is installed will also produce text/e-mail notifications.

- This sensor provides a relay closure that can be used to trip a fault when moisture is present. This can be used as a primary sump alarm or simply a wet basement or signal a blown washing machine hose.

AlpinePure MERV 13 Filter

A 2 in. [50 mm] thick MERV 13 filter shall be provided in lieu of the standard filter and fits the factory filter rack. The filter maintains MERV 13 rating in full ASHRAE 52.2 independent testing as required for LEED® certification. Helps fulfill a full credit under the LEED rating system.

AlpinePure HEPA Filter

For the ultimate in air filtration, the AlpinePure Series HEPA filter captures 99.97% of all particles down to 0.30 microns in size.

AlpinePure Drain Pan Treatment

Provides dependable, sustained time-release protection from slime build-up and foul smelling odors in the drain pan. Also adds a light, pleasant scent to the air.

Earth Loop Flow Center (field-installed)

A self-contained module shall provide all liquid flow, fill and connection requirements for ground source closed loop systems up to 20 gpm. The pumps shall be wired to a power block located in the nearest unit. The heat pump units shall contain low voltage pump linking control so that two units may share one flow center.

Auxiliary Heater (field-installed)

An electric resistance heater shall provide supplemental and/or emergency heating capability. Vertical units shall have the control panel and resistance heater coil assembly mounted internally. For horizontal units, the control panel shall be mounted internally while the resistance heater coil assembly shall be mounted externally. A low voltage plug shall be provided in each unit for quick auxiliary heat connection. The heater shall operate in sequenced stages as controlled by the unit's microprocessor. The heater shall feed line voltage power to the unit blower and transformer to provide emergency heat capability in the event of an open compressor circuit breaker.

Revision Guide

Pages:	Description:	Date:	By:
Misc.	Updated UPMXL info, wiring schematics, physical data, barcode	18 Nov 2022	MA
5	Updated Nomenclature	27 May 2021	MA
All	Released Aluminum Air Coil Option	1 Sept 2015	MA
All	Wiring Schematics Updated, Electric Heating Updated	11 June 2015	MA
All	First Published.	15 Mar 2013	DS



SC2500AG

11/22

Product: **Aston & Aston Advanced Series**
Type: Geothermal Heat Pumps
Size: 1-6 Ton Single Speed
2-6 Ton Dual Capacity

Document Type: Specification Catalog
Part Number: SC2500AG
Release Date: 11/22

